

Cat No. V042-E1-1

PC CONNECTION

Programmable Terminal

OPERATION MANUAL

OMRON

PLC CONNECTION

Programmable Terminal

Operation Manual

Produced April 1997

OMRON Product References

All OMRON products are capitalized in this manual. The word "Unit" is also capitalized when it refers to an OMRON product, regardless of whether or not it appears in the proper name of the product.

The abbreviation "Ch," which appears in some displays and on some OMRON products, often means "word" and is abbreviated "Wd" in documentation in this sense.

The abbreviation "PC" means Programmable Controller and is not used as an abbreviation for anything else.

The abbreviation "Host" means PC that controls NT20S.

Visual Aids

The following headings appear in the left column of the manual to help you locate different types of information.

Note Indicates information of particular interest for efficient and convenient operation of the product.

1, 2, 3... 1. Indicates lists of one sort or another, such as procedures, checklists, etc.

● Names of Devices and Tools

PT Refers to an OMRON NT series programmable terminal.

PC Refers to a Mitsubishi A series or FX series programmable controller.

System installer Refers to an OMRON NT series system installer.

Model	Applicable PC
NT30-ZS3AT-EMV1	Mitsubishi A series Mitsubishi FX series
NT620-ZS3AT-EMV1	Mitsubishi A series

? OMRON, 1997

All rights reserved. No part of this publication may be reproduced, stored in a retrieval system, or transmitted, in any form, or by any means, mechanical, electronic, photocopying, recording, or otherwise, without the prior written permission of OMRON.

No patent liability is assumed with respect to the use of the information contained herein. Moreover, because OMRON is constantly striving to improve its high-quality products, the information contained in this manual is subject to change without notice. Every precaution has been taken in the preparation of this manual. Nevertheless, OMRON assumes no responsibility for errors or omissions. Neither is any liability assumed for damages resulting from the use of the information contained in this publication.

TABLE OF CONTENTS

PRECAUTIONS	X
1 Intended Audience	xi
2 General Precautions	xi
3 Safety Precautions	xi
CHAPTER 1	
Connectable Hardware Combinations	1-1
1-1 Possible Combinations	1-2
1-2 Installing the System Program	1-3
1-3 Usable Support Tools	1-4
CHAPTER 2	
Use with Mitsubishi A Series Computer	
Link Systems	2-1
2-1 Usable PTs and PCs	2-2
2-2 Connection	2-4
2-3 Setting	2-10
2-4 Allocation Areas	2-17
2-5 Specific Errors and Their Remedies	2-21
CHAPTER 3	
Use with Mitsubishi FX	3-1
3-1 Applicable PTs and PCs	3-2
3-2 Connection	3-3
3-3 Setting	3-6
3-4 Allocation Areas	3-8
APPENDIX	APP-1
INDEX	

Related Manuals and Their Contents:

The related manuals are indicated below.

The * symbol at the end of the manual number is the revision history symbol.

[Connections between the programmable terminal (PT) and programmable controllers (PC), etc.]

This manual

- PC Connection, Operation Manual V042-E1-□

This Operation manual describes how to connect the programmable terminal (PT) to programmable controllers and other equipment, and how to make the settings required for these connections.

[For information on NT series PT functions, operations, and restrictions]

- NT20S Programmable Terminal Operation Manual V020-E1-□
- NT600S Programmable Terminal Operation Manual V022-E1-□
- NT30/NT30C Programmable Terminal Operation
Manual V034-E1-□
- NT620S/NT620C Programmable Terminal Operation
Manual V033-E1-□

These manuals contain full descriptions of NT series PT functions, operations, and restrictions.

How to Use the Manual

This Operation Manual comprises the following Chapters.

CHAPTER 1 Connectable Hardware Combinations

This chapter describes the combinations of PT and programmable controller that can be connected.

CHAPTER 2 Use with Mitsubishi A Series Computer Link Systems

This chapter describes how to make the connections and settings when a PT is connected to a Mitsubishi A series programmable controller in a computer link system.

CHAPTER 3 Use with Mitsubishi FX

This chapter describes how to make the connections and settings when a PT is connected to a Mitsubishi FX series programmable controller.

Appendix

This chapter describes the specifications of the connectors of OMRON products used for communications.

PRECAUTIONS

This section provides general precautions for using the Programmable Terminal.

The information contained in this section is important for the safe and reliable application of the Programmable Terminal. You must read this section and understand the information contained before attempting to set up or operate a Programmable Terminal.

1 Intended Audience	xi
2 General Precautions	xi
3 Safety Precautions	xi

1 Intended Audience

This manual is intended for the following personnel, who must also have knowledge of electrical systems (an electrical engineer or the equivalent).

- Personnel in charge of installing FA systems.
- Personnel in charge of designing FA systems.
- Personnel in charge of managing FA systems and facilities.

2 General Precautions

The user must operate the product according to the performance specifications described in the operation manuals.

Before using the product under conditions which are not described in the manual or applying the product to nuclear control systems, railroad systems, aviation systems, vehicles, combustion systems, medical equipment, amusement machines, safety equipment, and other systems, machines, and equipment that may have a serious influence on lives and property if used improperly, consult your OMRON representative.

Make sure that the ratings and performance characteristics of the product are sufficient for the systems, machines, and equipment, and be sure to provide the systems, machines, and equipment with double safety mechanisms.

This manual provides information for using the Programmable Terminal. Be sure to read this manual before attempting to use the software and keep this manual close at hand for reference during operation.

 **WARNING** It is extremely important that Programmable Terminals related devices be used for the specified purpose and under the specified conditions, especially in applications that can directly or indirectly affect human life. You must consult with your OMRON representative before applying Programmable Terminals to the abovementioned applications.

 **WARNING** Do not use input functions such as PT touch switches for applications where danger to human life or serious damage is possible, or for emergency switch applications.

3 Safety Precautions

In order to use this product safely and correctly, you must read and fully understand the “Safety Precautions” in the NT series Operation Manual before using it.

 **Caution** After connecting a communication cable, always secure it with the screws. Otherwise the cable may disconnect, causing operation to fail.

CHAPTER 1

Connectable Hardware Combinations

This chapter describes the connectable hardware combinations for each type of PT and each connection method. It also describes the types of system program used with NT30/NT30C, NT620S/NT620C.

1-1 Possible Combinations

The table below shows the combinations that can be connected.

PT Type	Model	Connector	Connection to Mitsubishi A (Computer Link)		Connection to Mitsubishi FX (Programming console)
			RS-232C	RS-422A	
NT20S	NT20S-ST121-EV3	RS-232C	○		○
NT600S	NT600S-ST121-EV3 NT600S-ST211-EV3	RS-232C	○		×
NT30/NT30C (*1)	NT30-ST131-E NT30C-ST141-E	RS-232C	○	☒	○
		RS-422A	☒	○	×
NT620S/NT620C (*1)	NT620S-ST211-E NT620C-ST141-E	RS-232C	○	☒	×

○: Direct connection

☒ Via RS-232C/RS-422A convertor unit

×: Connection not possible

(*1) In order to use NT30/NT30C, NT620S/NT620C in multi-vendor systems, a dedicated system program must be installed in the PT using the "NT series system installer".

The relationship between the PCs that can be connected and the direct connection version is shown in the table below.

	Connection to Mitsubishi A (Computer Link)	Connection to Mitsubishi FX (Programming console)
NT20S	V4, V5	V4, V5
NT600S	V4, V5	
NT30/NT30C	V4	V4
NT620S/NT620C	V1 to V4	

1-2 Installing the System Program

In order to use an NT30/NT30C or NT620S/NT620C in a multi-vendor system, a dedicated system program must be installed in the PT using the “NT series system installer” shown in the table below.

Model	Applicable PC
NT30-ZS3AT-EMV1	Mitsubishi A series Mitsubishi FX series
NT620-ZS3AT-EMV1	Mitsubishi A series

For details on how to operate the system installer, refer to its instruction manual, or the PT Operation manual.

Reference: Since NT20S and NT600S already have a dedicated system program written into them, this installation is not required for them. However, some PT models cannot be used in multi-vendor systems: check the situation for the model used by referring to “1-1 Possible Combinations” (page 1-2).

1-3 Usable Support Tools

When using the PT in a multi-vendor system, one of the following support tools must be used.

NT-ZA3AT-EV2 (Ver.2.3□)

The programmable controllers (PC) that can be connected to the PT are determined by the “Direct Macn Type” data set in the screen data memory board. Accordingly, screen data complying with the programmable controller to be connected must be transferred to the PT in advance.

The “Direct Macn Type” is set with the support tool. The applicable programmable controllers (PCs) depending on the “Direct Macn Type” setting are as follows.

Direct Macn Type	Applicable Programmable Controller (PLC)
NONE	For connections without direct connection (e.g. RS-232C)
OMRON	For connection to an OMRON C series or CVM1/CV series PC, or for a memory link connection.
MEL-A	For connection to a Mitsubishi Electric MELSEC A series PC
MEL-FX	For connection to a Mitsubishi Electric FX series PC

CHAPTER 2

Use with Mitsubishi A Series Computer Link Systems

This chapter describes how to make the connections and settings when a PT is connected to a Mitsubishi A series programmable controller in a computer link system.

2-1 Usable PTs and PCs

The PT, PC, and computer link module models that can be used in a computer link system that uses Mitsubishi A series PCs are indicated here.

Usable PT Models

The PT models that can be used with a computer link system that uses Mitsubishi A series PCs are tabled below.

When using NT30/NT30C, NT620S/NT620C, install the system program for Mitsubishi A computer links in advance with the "NT series system installer".

PT Type	Model
NT20S	NT20S-ST121□-EV3
NT600S	NT600S-ST121□-EV3 NT600S-ST211□-EV3
NT30	NT30-ST131□-E
NT30C	NT30C-ST141□-E
NT620S	NT620S-ST211□-E
NT620C	NT620C-ST141□-E

Reference: For the versions of the direct connection function that can be used, refer to "1-1 Possible Combinations" (page 1-2). For details on the direct connection function, refer to the Operation manual for the PT model used.

Modules Mounted at the Connected PC

Connections to a Mitsubishi A series PC are made at a computer link module. The table below lists the computer link modules to which the connection can be made with each type of connector.

Series	CPU Module	Computer Link Module Used	
		RS-232C	RS-422
A series	A0J2CPU A0J2HCPU	A0J2-C214S1	
	A1SCPU A1SJCPU A2SCPU A2USCPU A2USCPU-S1	A1SJ71C24-R2 A1SJ71UC24-R2	A1SJ71C24-R4 A1SJ71UC24-R4
	A1NCPU A2NCPU A2NCPU-S1 A3NCPU A3HCPU A3MCPU A2ACPU A2ACPU-S1 A3ACPU A2UCPU A2UCPU-S1 A3UCPU	AJ71C24-S8 AJ71UC24	

When the computer link module used is an AJ71C24-S8, A1SJ71C24-R2, or A1SJ71C24-R4, the device range is restricted to that usable with AnA models even if an AnU is used as the CPU module.

To use an extended device range with AnU, an A1SJ71UC24-R2, A1SJ71UC24-R4, or AJ71UC24 must be used.

2-2 Connection

The NT20S, NT600S and NT620S/NT620C have an RS-232C connector, while the NT30/NT30C have an RS-232C connector and an RS-422A terminal block; some computer link modules have an RS-232C connector and some have an RS-422A terminal block. This section describes the methods for connection with these connectors and terminal block.

Make cables that are suitable for the conditions of use, following the wiring details given in this section.

Parts Required for Connection

The connectors, connector covers, crimp terminals, and recommended cables for use with OMRON products are described here.

For details on the connectors, connector covers, and crimp terminals used at the computer link module side, refer to the manual for the computer link module.

● Parts for RS-232C (Common to PT and NT-AL001)

Part	Model	Remarks
Connector	XM2A-0901	9-pin type, made by OMRON
	DE-9P	9-pin type, made by JAE
Connector cover	XM2S-0911	9-pin type, made by OMRON
	DE-CI-J6	9-pin type, made by JAE
Cable	AWG28×5P IFVV-SB	Multi-core shielded cable, made by Fujikura, Ltd
	CO-MA-VV-SB 5P×28AWG	Multi-core shielded cable, made by Hitachi Cable, Ltd

● Recommended Parts for RS-422A Terminal Block (for NT30/NT30C)

<Appropriate crimp terminals>

Fork type

6.2 mm or less



Round type

6.2 mm or less



Part	Model	Remarks
Crimp terminal (M3.5)	2-YS3A	Fork type, made by Japan Solderless Terminal MFG
	2-YAS3.5	Fork type, made by Fuji Terminal
	2Y-3.5	Fork type, made by Nichifu Terminal
	2-3.5	Round type, made by Japan Solderless Terminal MFG
	V2-S3.5	Round type, made by Fuji Terminal
	2-3.5	Round type, made by Nichifu Terminal
Cable	H-9293A (CO-HC-ESV-3P×7/0.2)	Made by Hirakawa Hewtech corp.

● **Recommended Parts for RS-422A Terminal Blocks (For NT-AL001)**

<Appropriate crimp terminals>

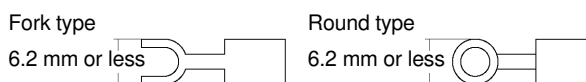

Part	Model	Remarks
Crimp terminal (M3) (*1)	Y1.25-3.5L	Fork type, made by molex
	1.25-N3A	Fork type, made by Japan Solderless Terminal MFG

(*1) Appropriate wire size: 0.3 to 0.75 mm²

Connection Between RS-232C (PT) and RS-232C (Computer Link)

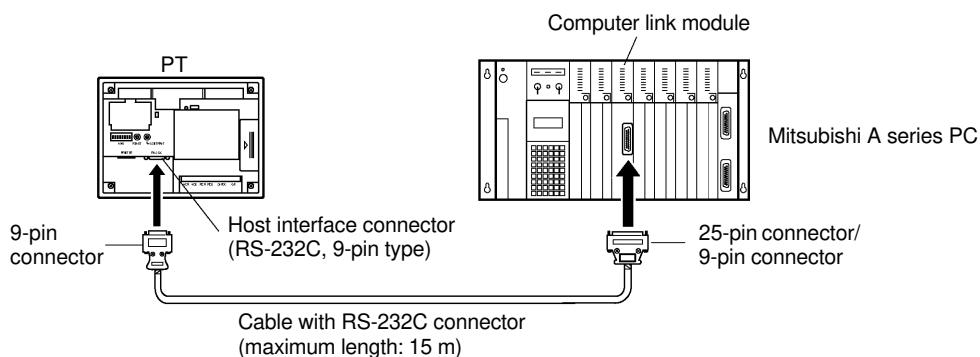

Caution: After connecting a communication cable, always secure it with the screws. Otherwise the cable may disconnect, causing operation to fail.

● **Wiring When Computer Link Module has a 25-pin Connector**

There is a shielding wire at the computer link module side only: connect it to the connector cover and to the No.1 pin (FG).

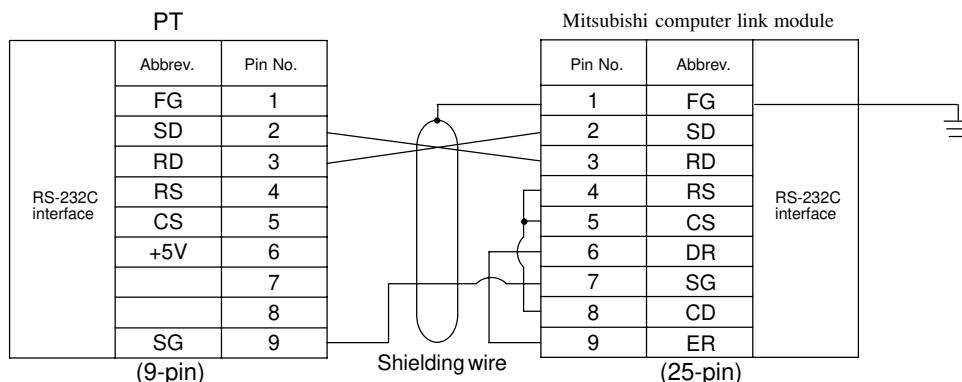

● Wiring When Computer Link Module has a 9-pin Connector

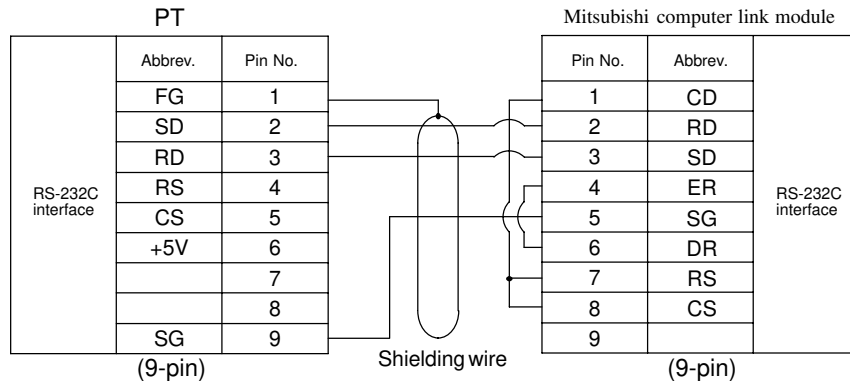

Connection Between RS-232C (PT) and RS-422A (Computer Link Module)

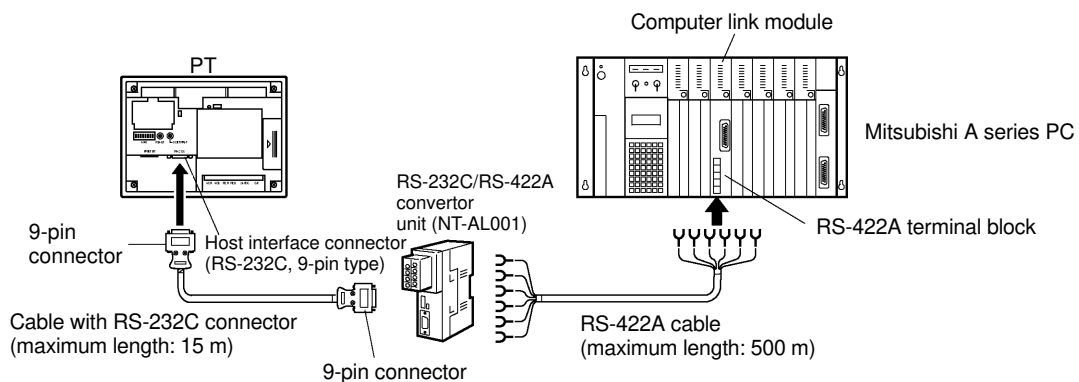

Caution: After connecting a communication cable, always secure it with the screws. Otherwise the cable may disconnect, causing operation to fail.

Note: When connecting to a terminal block, always use crimp terminals.

● Wiring Between PT and NT-AL001

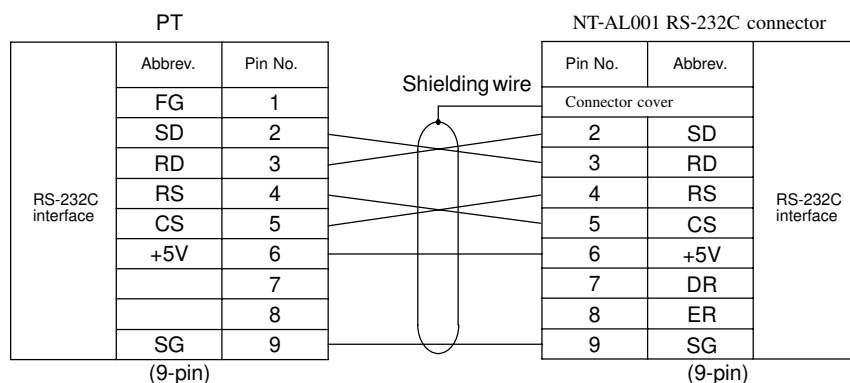

● **Wiring Between NT-AL001 and Computer Link Module**

Make the connections between SDB and SDA, and RDB and RDA, with twisted pair wires

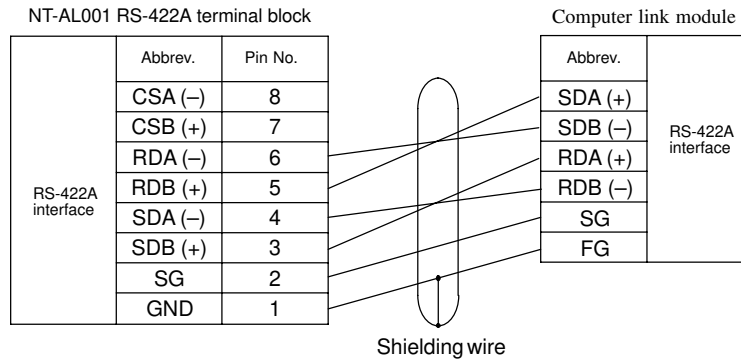

Connection Between RS-422A (PT) and RS-422A (Computer Link Module)

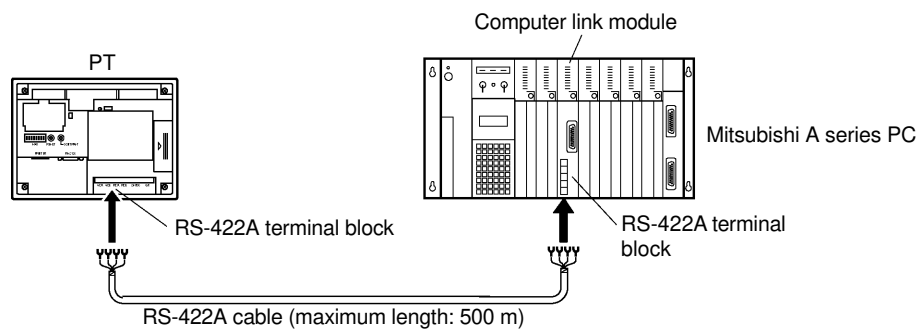

Note: When connecting to a terminal block, always use crimp terminals.

● **Wiring**

Make the connections between SDB and SDA, and RDB and RDA, with twisted pair wires.

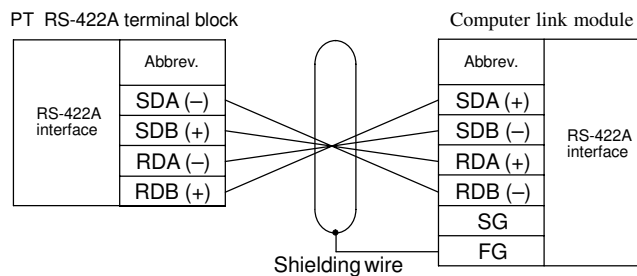

Connection Between RS-422A (PT) and RS-232C (Computer Link)

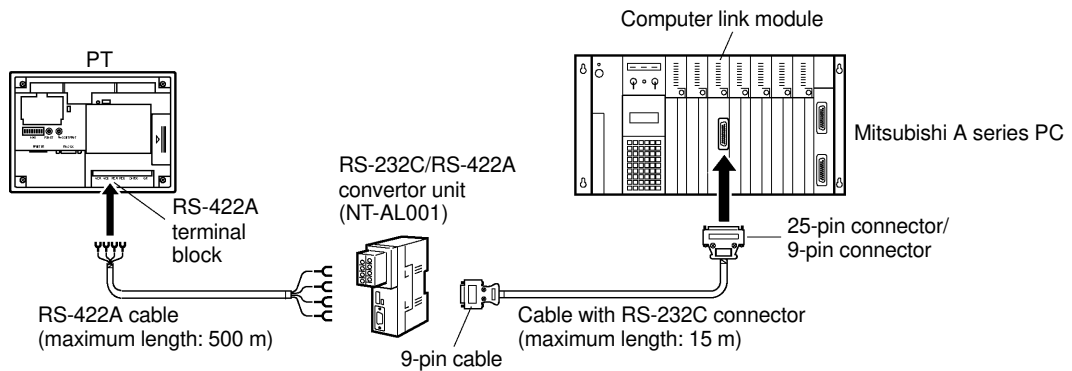

Caution: After connecting a communication cable, always secure it with the screws. Otherwise the cable may disconnect, causing operation to fail.

Note: When connecting to a terminal block, always use crimp terminals.

● Wiring Between PT and NT-AL001

Make the connections between SDB and SDA, and RDB and RDA, with twisted pair wires.

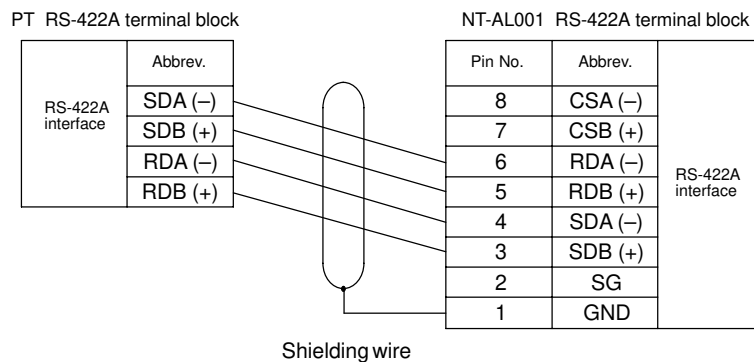

● **Wiring to NT-AL001 when Computer Link Module has 25-pin Connector**

Connect the power supply to the NT-AL001 (5 VDC) at pin No.6 (+5V) and pin No.9 (SG) of the RS-232C connector.

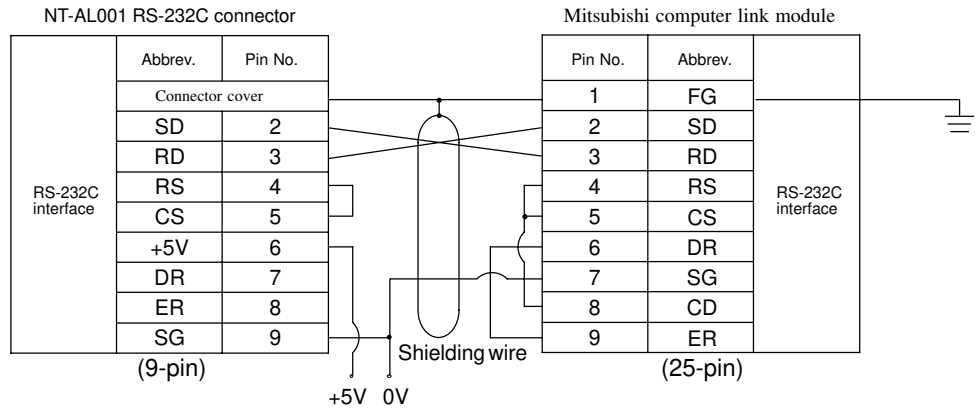

● **Wiring to NT-AL001 when Computer Link Module has 9-pin Connector**

Connect the power supply to the NT-AL001 (5 VDC) at pin No.6 (+5V) and pin No.9 (SG) of the RS-232C connector.

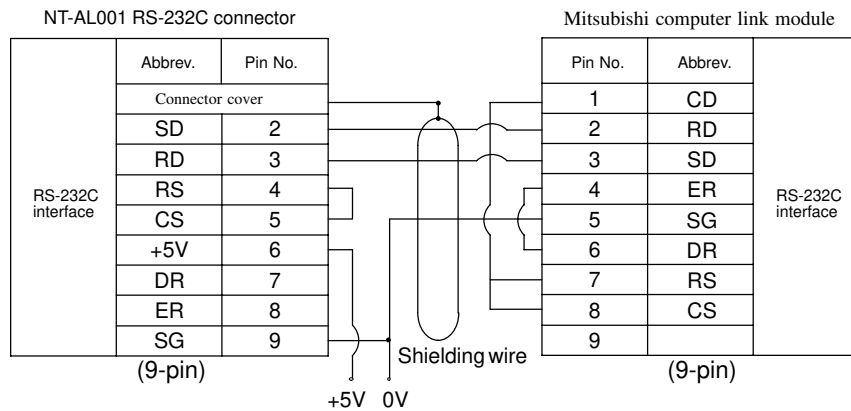

2-3 Setting

This chapter describes the settings required at each device in order to use a computer link system that uses Mitsubishi A series PCs.

Settings at the PT

Make the following settings in the PT's maintenance mode by using the memory switches. When using NT30/NT30C or NT620S/NT620C, install the system program for Mitsubishi A computer links in advance using the "NT series system installer".

Reference: Set the other memory switches in accordance with the conditions of use.

Item	Setting
Port select (NT30/NT30C only)	RS-232C or RS-422
Comm. Type (*)	Computer link
Baud Rate	9600 bps or 19200 bps
PC type	AnN, AnA, or AnU

*: The screen representation of the items to be set differs a little according to the PT model.

For the "PC type" item, set the type of CPU module as follows.

Setting	CPU Module		
AnN	A0J2CPU A1SCPU A2SCPU A3NCPU	A0J2HCPU A1SJCPU A2NCPU A3HCPU	A2NCPU-S1 A3MCPU
AnA	A2ACPU A3ACPU	A2ACPU-S1	
AnU	A2UCPU A2USCPU A3UCPU	A2UCPU-S1 A2USCPU-S1	

NT30/NT30C DIP switch settings

When using RS-422A with NT30/NT30C, set DIP switches 2 to 8 to "ON" (terminal resistor used).

Reference: Set the other DIP switches in accordance with the conditions of use.

Settings for NT-AL001

When using the RS-232C/RS-422 convertor unit (NT-AL001), set the RS-422A communication conditions with the DIP switches as shown in the figure below.

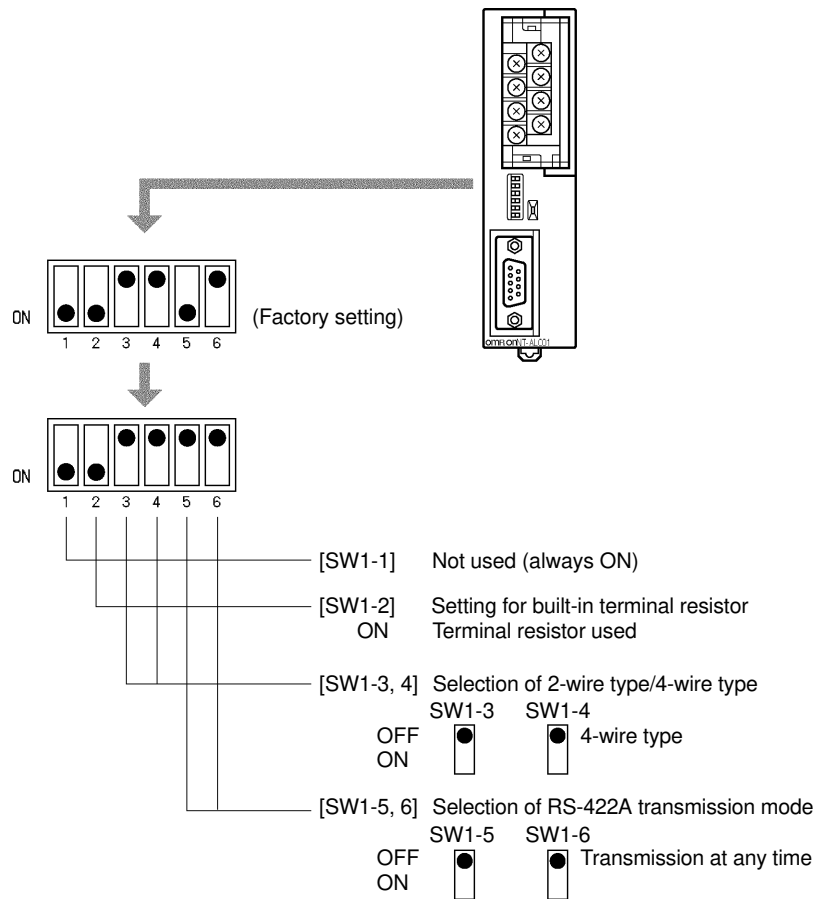

Computer Link Module Settings

After connecting the PT and PC, set the conditions in the table below at the computer link module at the PC side.

Set these conditions using the switches provided on each type of module by following the instructions given below.

For a detailed explanation of the setting method, refer to the Operation Manual for each module.

Item	Setting	
	When using an RS-232C connector	When using an RS-422A terminal block
I/O port	RS-232C	RS-422A
Baud rate	Set the same baud rate as set at the PT.	
Transmission format	ASCII 7 bits, 2 stop bits	
Parity	Even	
Control protocol	Type 1	Type 5
Unit No. (Station number)	00	

<A0J2-C214S1>

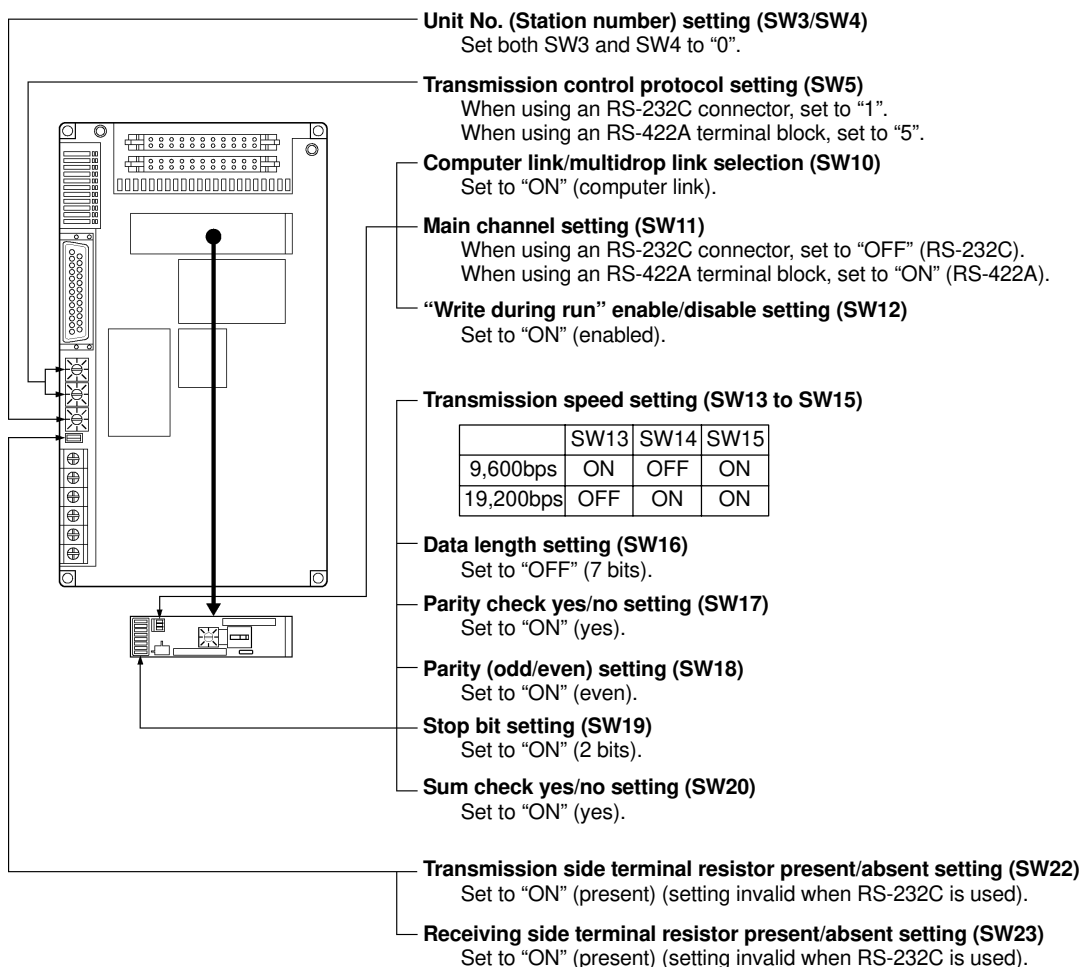

<AJ71C24-S8>

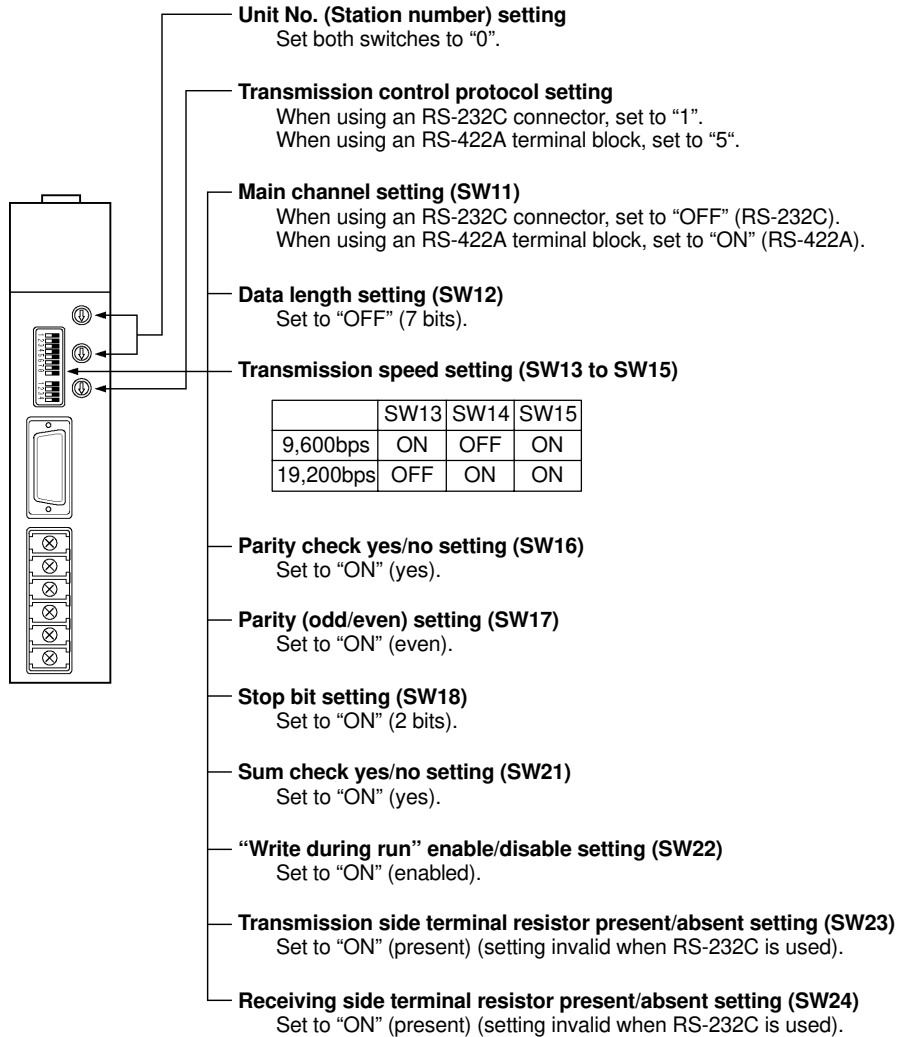

<AJ71UC24>

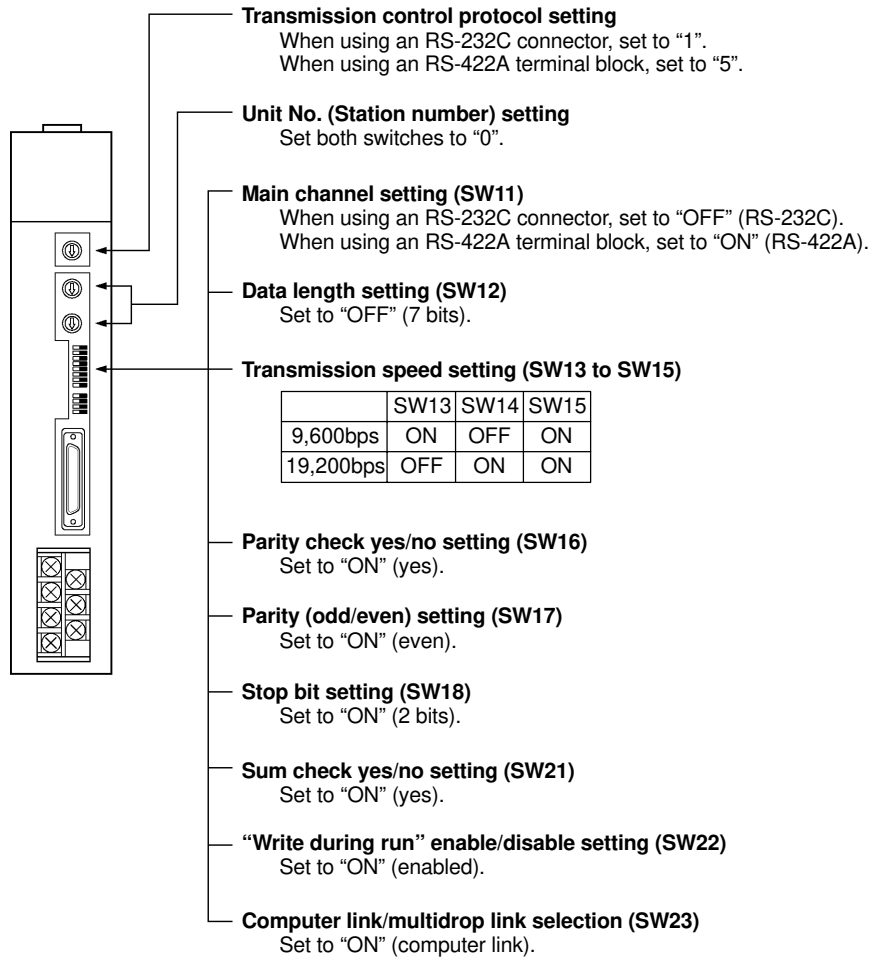

<A1SJ71UC24-R2, A1SJ71C24-R2> (RS-232C dedicated)

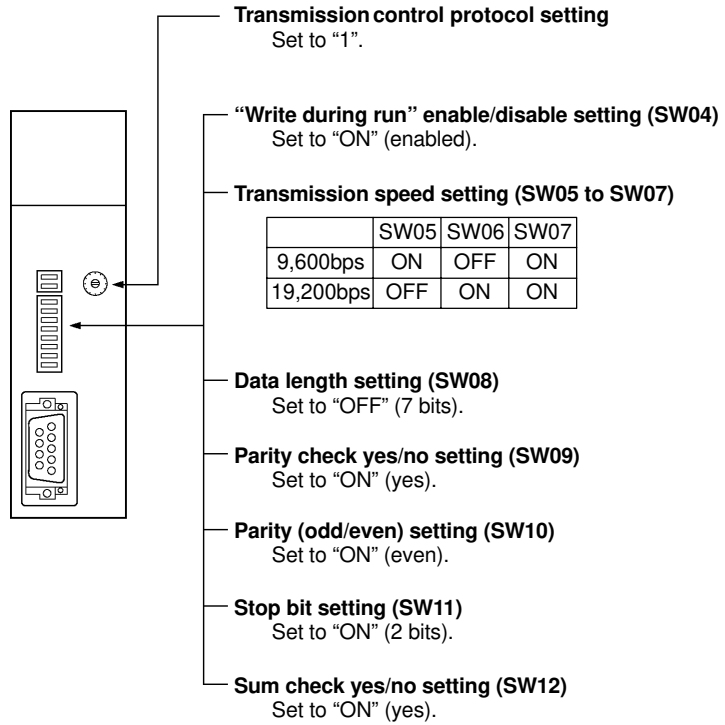

<A1SJ71UC24-R4, A1SJ71C24-R4> (RS-422A dedicated)

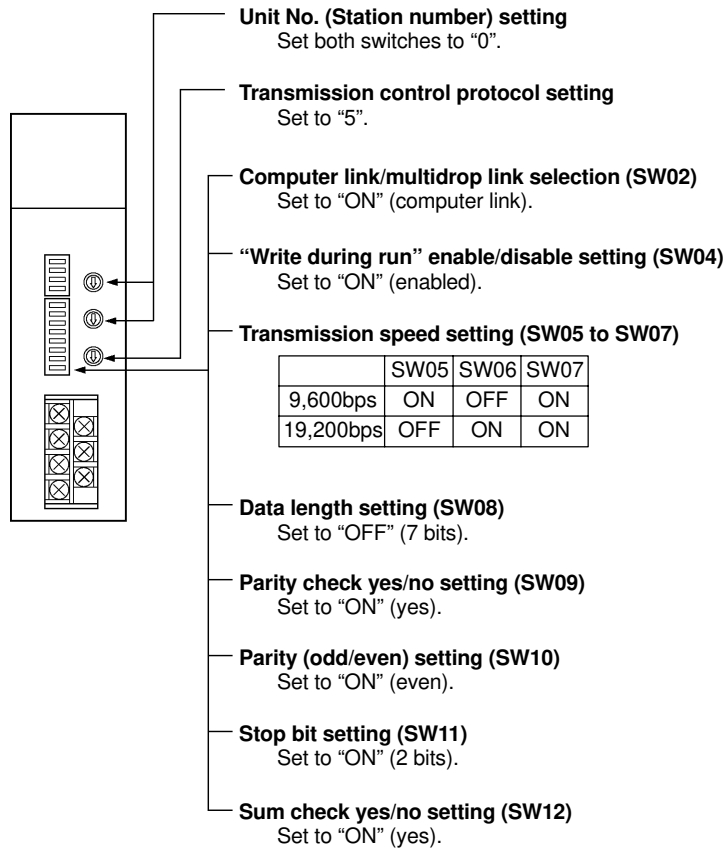

2-4 Allocation Areas

This chapter describes the types of area to which bits and words can be allocated, and the ranges of these areas for each PC.

Bits and Words Allocated to the PC

Bits and words can be allocated to Mitsubishi A series PCs as follows.

Symbol	Area Name	Bit	Word	
			Numeric Value	Character String(*)
D	Data registers	✓	✓	✓
M	Internal relays	✓	✓	✓
T	Timers	×	☒	×
C	Counters	×	☒	×
L	Latching relays	✓	✓	✓
B	Link relays (hexadecimal input)	✓	✓	✓
W	Link registers (hexadecimal input)	✓	✓	✓
X	Input relays (hexadecimal input)	✓	✓	✓
Y	Output relays (hexadecimal input)	✓	✓	✓
R	File registers	✓	✓	✓

(*) Includes the PT status control area and PT status notify area

✓: Possible ☒ Possible (1 word only) ×: Not possible

● Restrictions on Use

The restrictions and cautions that apply specifically when using a PT with a computer link system that uses Mitsubishi A series PCs are presented here. For details on other, general restrictions, refer to the Operation manual for the PT.

Screen switching

To switch screens by specifying a screen number in the “screen switch setting” of the PT status control area, specify the screen number in BCD (binary coded decimal).

Specifying memory table numbers

When specifying memory table numbers in the PT status control area, and when specifying memory table numbers by indirect specification, use BCD (binary coded decimal).

Setting the PT Clock function

When setting the time with the PT's internal clock function, specify the value in BCD (binary coded decimal).

Bit notification

When elements for which statuses are notified by bits - such as touch switches, extended I/O inputs, bit memory tables, etc. - are allocated to word devices (D, W, R), since the notification is in word units, all bits other than those used for the notification will be set to "0" (OFF).

Mitsubishi A Series PC Allocation Areas

PC \ Area	Bit Devices (Bit Units)					
	Input Relays (X)	Output Relays (Y)	Link Relays (B)	Internal Relays (M)	Latch Relays (L)	Special Internal Relays (M)
A0J2CPU	0000 to 01DF	0000 to 01DF	B0000 to B03FF	M0000 to M2047	L0000 to L2047	M9000 to M9255
A0J2HCPU	0000 to 01DF	0000 to 01DF				
A1SCPU	0000 to 00FF	0000 to 00FF				
A1SJCPU	0000 to 00FF	0000 to 00FF				
A2SCPU	0000 to 01FF	0000 to 01FF				
A2NCP	0000 to 01FF	0000 to 01FF				
A2NCP-S1	0000 to 03FF	0000 to 03FF				
A3NCP	0000 to 07FF	0000 to 07FF				
A3HCP	0000 to 07FF	0000 to 07FF				
A3MCP	0000 to 07FF	0000 to 07FF				
A2ACP	0000 to 01FF	0000 to 01FF	B0000 to B0FFF	M0000 to M8191	L0000 to L8191	M9000 to M9255
A2ACP-S1	0000 to 03FF	0000 to 03FF				
A3ACP	0000 to 07FF	0000 to 07FF				
A2UCP	0000 to 01FF	0000 to 01FF	B0000 to B1FFF			
A2UCP-S1	0000 to 03FF	0000 to 03FF				
A2USCP	0000 to 01FF	0000 to 01FF				
A2USCP-S1	0000 to 03FF	0000 to 03FF				
A3UCP	0000 to 07FF	0000 to 07FF				

- Notes:**
- The values indicated in the table above are the ranges that can actually be set with the support tool and used by the PT.
 - The ranges actually usable differ according to the system configuration.

PC \ Area	Word Devices					
	Data Registers (D)	Timers (T)	Counters (C)	Link Registers (W)	File Registers (R)	Special Data Registers (D)
A0J2CPU	D0000 to D1023	T0000 to T0255	C0000 to C0255	W0000 to W03FF	–	D9000 to D9127
A0J2HCPU					R0000 to R4095	D9000 to D9255
A1SCPU						
A1SJCPU						
A2SCPU						
A2NCPU						
A2NCPU-S1						
A3NCPU						
A3HCPU						
A3MCPU						
A2ACPU	D0000 to D6143	T0000 to T2047	C0000 to C1023	W0000 to W0FFF	R0000 to R8191	D9000 to D9255
A2ACPU-S1						
A3ACPU						
A2UCPU	D0000 to D8191	T0000 to T2047	C0000 to C1023	W0000 to W1FFF		
A2UCPU-S1						
A2USCPU						
A2USCPU-S1						
A3UCPU						

- Notes:**
- The values indicated in the table above are the ranges that can actually be set with the support tool and used by the PT.
 - The ranges actually usable differ according to the system configuration.
 - The values accessed with timers and counters are the timer and counter present values.

2-5 Specific Errors and Their Remedies

This chapter describes the specific errors that may occur when using the PT in a computer link system that uses Mitsubishi A series PCs, and the remedies to employ when they occur.

Setting Errors

If an area that does not exist in the PC is specified when creating a PT screen with the support tool, the screen shown below is displayed during PT operation.

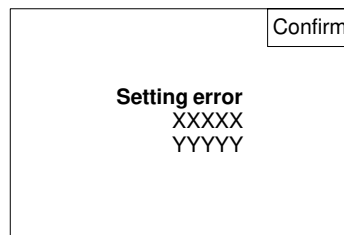

XXXXX: Device type
 YYYYY: Device number

If this happens, first check that the area at the PC being used has been secured, then set the correct device.

Reception Errors

If a reception error occurs during PT operation, the screen shown below is displayed.

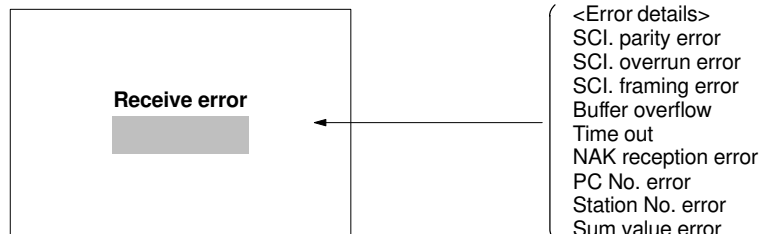

The errors that occur specifically with computer link systems that use Mitsubishi A series PCs are described below. For details on errors other than those indicated below, refer to the Operation manual for the PT.

Message	Cause	Corrective Action
PC Number error	<ul style="list-style-type: none"> • Due to noise, the data has been changed on the transmission line. 	<ul style="list-style-type: none"> • If the system is used at a site subject to a lot of noise, use cables with protection against noise on the transmission route.
Exchange No. error	<ul style="list-style-type: none"> • The station No. at the PC side has been changed. • The PC has sent erroneous data. • Due to noise, the data has been changed on the transmission route. 	<ul style="list-style-type: none"> • Set the station No. at the PC side to "0". • Check the operation at the PC side. • If the system is used at a site subject to a lot of noise, use cables with protection against noise on the transmission route.
Sum check error	<ul style="list-style-type: none"> • The PC has sent erroneous data. • Due to noise, the data has been changed on the transmission line. 	<ul style="list-style-type: none"> • Check the operation at the PC side. • If the system is used at a site subject to a lot of noise, use cables with protection against noise on the transmission route.

CHAPTER 3

Use With Mitsubishi FX

This chapter describes how to make the connections and settings when a PT is connected to a Mitsubishi FX series programmable controller.

3-1 Applicable PTs and PCs

The PT and PC models that can be used with Mitsubishi FX series PCs are indicated here.

Usable PT Models

The PT models that can be used with the Mitsubishi FX series are tabled below. When using NT30/NT30C, install the system program for Mitsubishi FX in advance using the "NT series system installer".

PT Type	Model
NT20S	NT20S-ST121□-EV3
NT30 (*)	NT30-ST131□-E
NT30C (*)	NT30C-ST141□-E

(*) Only an RS-232C connector can be used.

Reference: For the versions of the direct connection function that can be used, refer to "1-1 Possible Combinations" (page 1-2). For details on the direct connection function, refer to the Operation manual for the PT model used.

Modules mounted at the Connected PC

When the connection is to a Mitsubishi FX series PC, the programming console connector of the main base unit is used. The table below lists main base units to which connection is possible.

Type	Mode					
FX ₀	FX ₀ -14MR FX ₀ -14MR-D	FX ₀ -20MR FX ₀ -20MR-D	FX ₀ -30MR FX ₀ -30MR-D	FX ₀ -14MT FX ₀ -14MT-D	FX ₀ -20MT FX ₀ -20MT-D	FX ₀ -30MT FX ₀ -30MT-D
FX _{0N}	FX _{0N} -40MR	FX _{0N} -60MR	FX _{0N} -40MT	FX _{0N} -60MT		
FX ₁	FX ₁ -16MR FX ₁ -16MT	FX ₁ -24MR FX ₁ -24MT	FX ₁ -32MR FX ₁ -32MT	FX ₁ -48MR FX ₁ -48MT	FX ₁ -64MR FX ₁ -64MT	FX ₁ -80MR FX ₁ -80MT
FX ₂	FX ₂ -16MR FX ₂ -128MR FX ₂ -16MS FX ₂ -16MT FX ₂ -128MT	FX ₂ -24MR FX ₂ -24MS FX ₂ -24MT	FX ₂ -32MR FX ₂ -32MS FX ₂ -32MT	FX ₂ -48MR FX ₂ -48MS FX ₂ -48MT	FX ₂ -64MR FX ₂ -64MS FX ₂ -64MT	FX ₂ -80MR FX ₂ -80MS FX ₂ -80MT
	FX ₂ -24MR-A1 FX ₂ -24MR-D FX ₂ -48MT-D FX ₂ -32MT-C	FX ₂ -48MR-A1 FX ₂ -48MR-D FX ₂ -80MT-D FX ₂ -64MT-C	FX ₂ -64MR-A1 FX ₂ -64MR-D	FX ₂ -80MR-D		
FX _{2c}	FX _{2c} -64MT	FX _{2c} -96MT	FX _{2c} -128MT	FX _{2c} -160MT		

3-2 Connection

The connection is made between the RS-232C connector of the PT to the Mitsubishi FX series PC via an RS-232C/RS-422A convertor unit (type NT-AL001). Make the cables in accordance with the wiring schemes shown in this section, and in accordance with the conditions of use.

Parts Required for Connection

The connectors, connector covers, crimp terminals, and recommended cables for use with OMRON products are described here.

For details on the connectors, connector covers, and crimp terminals used with Mitsubishi products, refer to the manual for the Mitsubishi product.

● Parts for RS-232C connector (Common to PT and NT-AL001)

Part	Model	Remarks
Connector	XM2A-0901	9-pin type, made by OMRON
	DE-9P	9-pin type, made by JAE
Connector cover	XM2S-0911	9-pin type, made by OMRON
	DE-CI-J6	9-pin type, made by JAE
Cable	AWG28X5P IFVV-SB	Multi-core shielded cable, made by Fujikura, Ltd
	CO-MA-VV-SB 5PX28AWG	Multi-core shielded cable, made by Hitachi Cable, Ltd

● Recommended Parts for RS-422A Terminal Blocks (For NT-AL001)

<Appropriate crimp terminals>

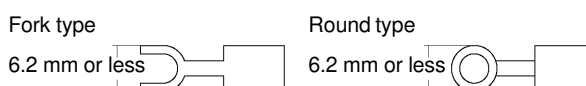

Part	Model	Remarks
Crimp terminal (M3) (*1)	Y1.25-3.5L	Fork type, made by Molex
	1.25-N3A	Fork type, made by Japan Solderless Terminal MFG

(*1) Appropriate wire size: 0.3 to 0.75 mm²

Connection Method

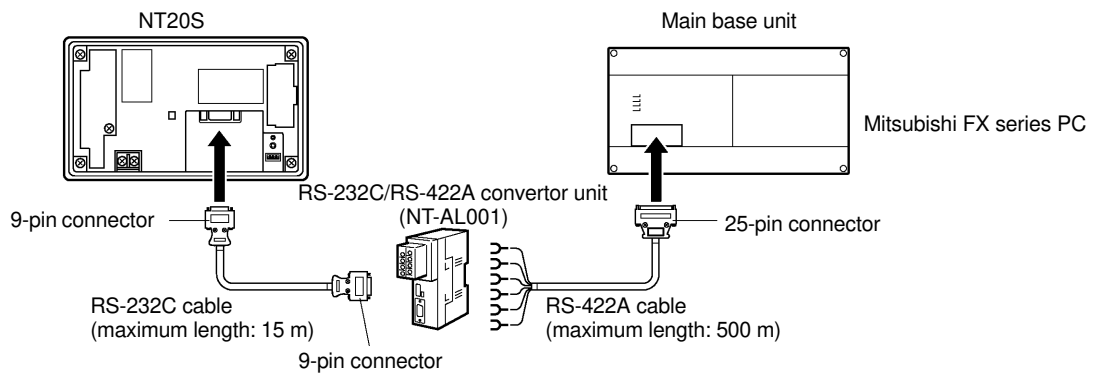

⚠ Caution: After connecting a communication cable, always secure it with the screws. Otherwise the cable may disconnect, causing operation to fail.

Note: When connecting to a terminal block, always use crimp terminals.

● Wiring Between PT and NT-AL001

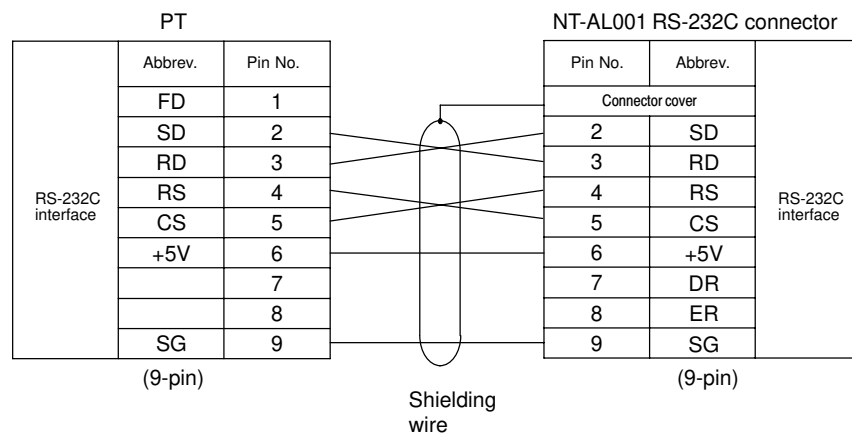

● **Wiring Between NT-AL001 and PC**

When using FX1, FX2, and FX2C, connect a cable with the wiring scheme shown below directly to the programming console connector of the PC.

The programming console connectors of FX0 and FX0N have a different shape; with these types connect a cable with the wiring scheme shown below to an FX-20P-CADP cable made by Mitsubishi, then connect the FX-20P-CADP to the programming console connector of the PC.

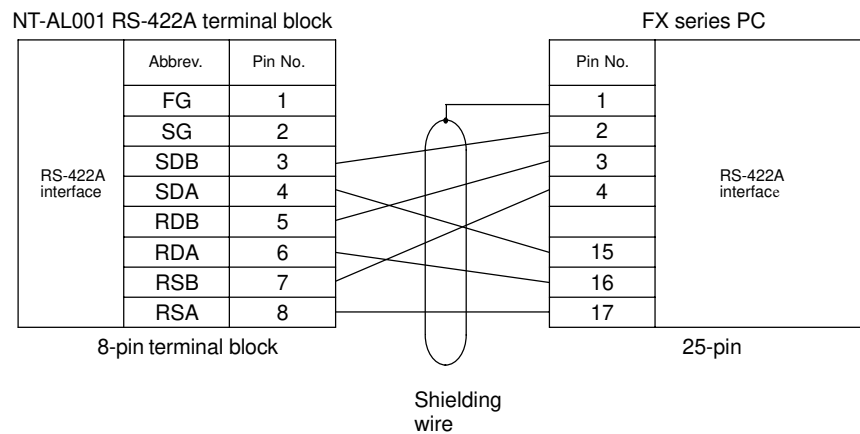

Make the connections between SDB and SDA, RDB and RDA, and RSB and RSA, with twisted pair wires.

3-3 Setting

This chapter describes the settings required at each device in order to use the programming console connector of a Mitsubishi FX series PC.

Settings at the PT

Make the following settings in the PT's maintenance mode by using the memory switches. When using NT30/NT30C, install the system program for Mitsubishi FX in advance using the "NT series system installer".

Reference: Set the other memory switches in accordance with the conditions of use.

● When using NT20S

Item	Setting
Comm. Type	With FX ₀ :MELSEC-FX0
	With FX _{0N} :MELSEC-FX0N
	With FX ₁ :MELSEC-FX1
	With FX ₂ , FX _{2C} :MELSEC-FX2

● When using NT30/NT30C

Item	Setting
Port select	RS-232C
Comm. Type	With FX ₀ :MELSEC-FX0
	With FX _{0N} :MELSEC-FX0N
	With FX ₁ :MELSEC-FX1
	With FX ₂ , FX _{2C} :MELSEC-FX2

Settings at the NT-AL001

When using the RS-232C/RS-422 convertor unit (NT-AL001), set the RS-422A communication conditions with the DIP switches as shown in the figure below.

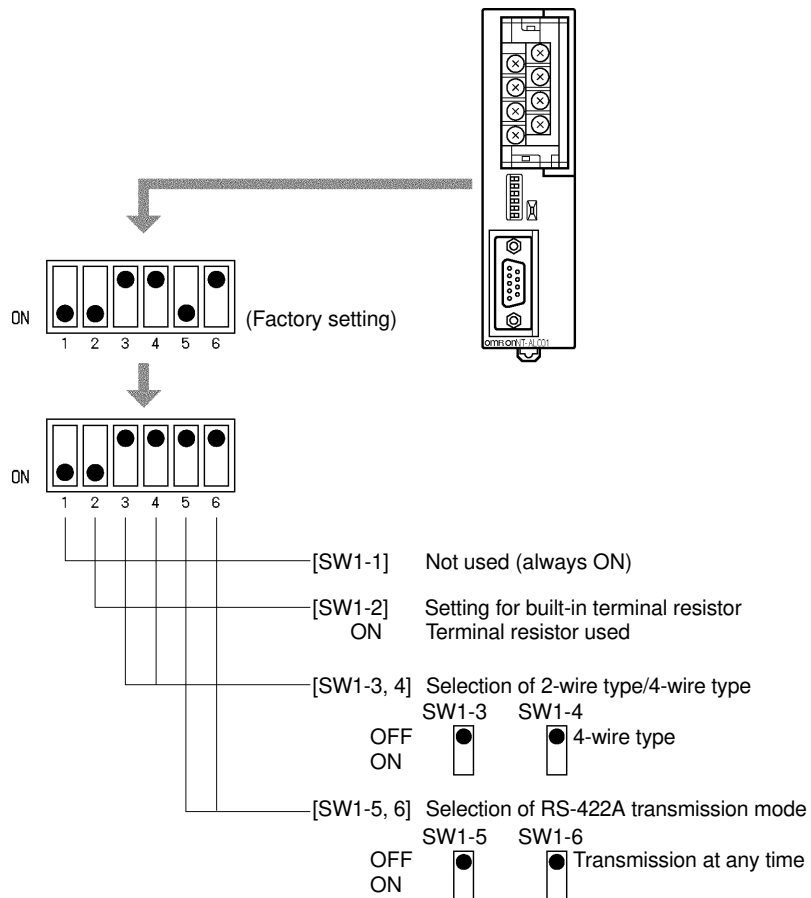

PC Settings

No particular settings have to be made at the PC in order to use the PT with a programming console connector.

3-4 Allocation Areas

This chapter describes the types of area to which bits and words can be allocated, and the ranges of these areas for each PC.

Bits and Words Allocated to the PC

Bits and words can be allocated to Mitsubishi FX series PCs as follows.

Symbol	Area Name	Bit	Word	
			Numeric Value	Character String(*)
D	Data registers	×	✓	✓
M	Internal relays	✓	✓	✓
T	Timers	×	②	×
C	Counters	×	②	×
S	State relays	✓	✓	✓
X	Input relays	✓	✓	✓
Y	Output relays	✓	✓	✓

(*) Includes the PT status control area and PT status notify area

✓ : Possible

② : Possible (1 word only)

② : For C0 to C199, 1 word possible; for C200 and higher, 2 words possible

× : Not possible

Reference: Allocations cannot be made to the special use areas for data registers (D) and auxiliary registers (M).

● Restrictions on Use

The restrictions and cautions that apply specifically when using a PT with the programming console connector of a Mitsubishi FX series PC are presented here. For details on other, general restrictions, refer to the Operation manual for the PT.

Screen switching

To switch screens by specifying a screen number in the “screen switch setting” of the PT status control area, specify the screen number in BCD (binary coded decimal).

Specifying memory table numbers

When specifying memory table numbers in the PT status control area, and when specifying memory table numbers by indirect specification, use BCD (binary coded decimal).

Setting the PT Clock function

When setting the time with the PT's internal clock function, specify the value in BCD (binary coded decimal).

Bit notification

When elements for which statuses are notified by bits - such as touch switches, extended I/O inputs, bit memory tables, etc. since the notification is in word units, all bits other than those used for the notification will be set to "0" (OFF).

Bit and Word Allocations to Bit Devices (M, S, X, Y)

The allocation of bits and words to bit devices (M, S, X, Y) is described here. For details on the ranges of the areas within which specification is possible, refer to "Mitsubishi FX Series PC Allocation Areas" (page 3-11).

● Bit Allocations

When allocating bits to bit devices, any number not outside the range for the area can be specified. However, since host link access is in word (16 bit) units, the following points must be observed when allocating bits.

- Points to note when allocating to M (special relays) and S (state relays)
M and S devices are bit devices expressed in decimal in the case of Mitsubishi FX series PCs. However, in the host link, data is written in word (16-bit) units. Therefore, when data is written, all other bits in the same word are cleared to "0" ("other bits in the same word" here means bits which have the same quotient when divided by 16).
- Points to note when allocating to X (input relays) and Y (output relays)
X and Y devices are bit devices expressed in octal in the case of Mitsubishi FX series PCs. However, host link writing is in word (16-bit) units. Therefore, when data is written, all other bits in the same word are cleared to "0" (since one word is 16 bits, each of the following sequences of bits (least significant two digits) is contained within one word: 00 to 17, 20 to 37, 40 to 57, and 60 to 77).

● **Word Allocations**

When allocating bits to bit devices, the following points relating to the method of specification must be observed.

- Points to note when allocating to M (special relays) and S (state relays)
M and S devices are bit devices expressed in decimal in the case of Mitsubishi FX series PCs. However, inside the PC, the bits are actually managed in units of 16. Therefore, when accessing words using word allocation, make the specification so that the first bit number is a multiple of 16.
- Points to note when allocating to X (input relays) and Y (output relays)
X and Y devices are bit devices expressed in octal in the case of Mitsubishi FX series PCs. Therefore, when accessing words using word allocation, ensure that the least significant two digits of the first bit number are “00”, “20”, “40”, or “60”.

The area used for word allocation is as follows.

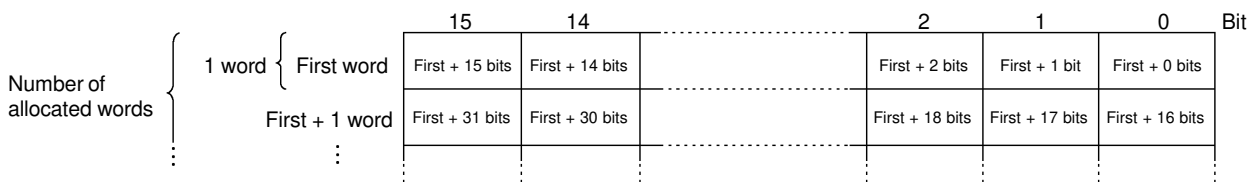

Word Allocations to Word Devices (D, T, C)

Word allocations to word devices (D, T, C) are described here.

It is impossible to make bit allocations to word devices.

Normally one word device occupies one word (16 bits). Therefore, when allocating a word to a word device, any number not outside the range for the area can be specified. However, in the case of counters C200 and higher, one word device is 32 bits, i.e., it occupies 2 words. For details on the ranges of the areas within which specification is possible, refer to “Mitsubishi FX Series PC Allocation Areas” (page 3-11).

The area used for word specification is as follows.

• **Normal device**

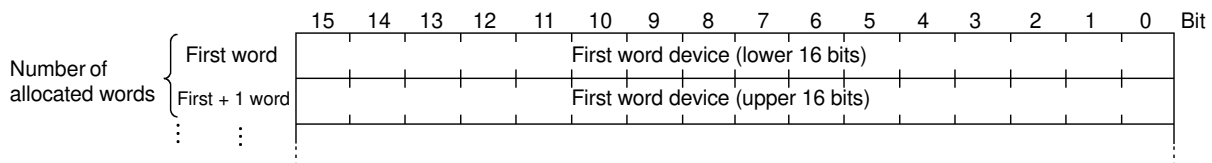

• 32-bit devices from C200 onward

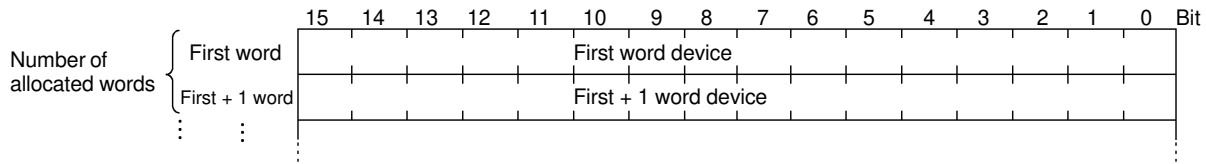

Mitsubishi FX Series PC Allocation Areas

Type	Unit	Data Registers (D)	Auxiliary Relays (M)	Timers (T)	Counters (C)	State Relays (S)	Input Relays (X)	Output Relays (Y)
FX ₀	Bit	—	M0 to M511	—	—	S0 to S63	X0 to X177	X0 to X177
FX _{0N}	Word	D0 to D31	M0 to M496	T0 to T55	C0 to C254	S0 to S48	X0 to X17	Y0 to Y17
FX ₁	Bit	—	M0 to M1023	—	—	S0 to S999	X0 to X177	X0 to X177
	Word	D0 to D127	M0 to M1008	T0 to T245	C0 to C254	S0 to S984	X0 to X17	Y0 to Y17
FX ₂ FX _{2C}	Bit	—	M0 to M1023	—	—	S0 to S999	X0 to X177	X0 to X177
	Word	D0 to D511	M0 to M1008	T0 to T255	C0 to C255	S0 to S984	X0 to X17	Y0 to Y17

- Notes:**
- The values indicated in the table above are the ranges that can actually be set with the support tool and used by the PT.
 - The ranges actually usable differ according to the system configuration.

+

APPENDIX

This chapter describes the specifications of the connectors of OMRON products used for communications.

APPENDIX A

OMRON Product Connector Specifications

PT Connectors

● **RS-232C connector specifications**

- Connector type : RS-232C connector (9-pin)
- Electrical characteristics : Conform to EIA RS-232C
- Connection signals

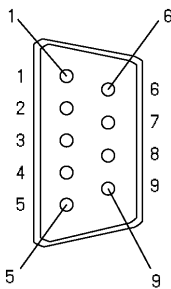

Connector Pin No.	Signal Name	Abbreviation	Signal Direction PT ↔ External Device
1	Not used	—	—
2	Send data	SD (TxD)	↗
3	Receive data	RD (RxD)	↖
4	Request to send	RS (RTS)	↗
5	Clear to send	CS (CTS)	↖
6	+5V for convertor (max. 150 mA)	+5V	↗
9	Signal ground	SG	—

● **RS-422A terminal block specifications (NT30/NT30C only)**

- Connected terminal block : RS-422A terminal block (M3.5 screw)
- Electrical characteristics : Conform to EIA RS-422A
- Connection signals

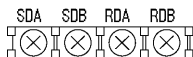

Signal Name	Abbreviation	Signal Direction PT ↔ External Device
Send data (–)	SDA	↗
Send data (+)	SDB	↖
Receive data (–)	RDA	↗
Receive data (+)	RDB	↖

RS-232C/RS-422 Converter Unit (NT-AL001)

● RS-232C connector specifications

- Connector type : RS-232C connector (9-pin)
- Electrical characteristics : Conform to EIA RS-232C
- Connection signals

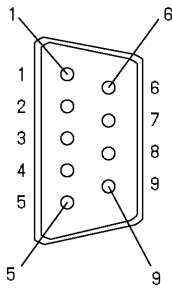

Connector Pin No.	Signal Name	Abbreviation	Signal Direction PT ↔ External Device
Connector cover	Grounding or earth for safety purposes	FG	—
1	Not used	—	—
2	Send data	SD (TxD)	↗
3	Receive data	RD (RxD)	↖
4	Receive dataRequest to send (shorted to CS internally)	RS (RTS)	↖
5	Clear to send (shorted to RS internally)	CS (CTS)	↖
6	+5V for convertor (150 mA)	+5V	↖
7	Data set ready (shorted to ER internally) *	DR (DSR)	— *
8	Data terminal ready (shorted to DR internally) *	ER (DTR)	— *
9	Signal ground	SG (GND)	—

- The connector cover is connected to the functional ground terminal (pin No.1) of the RS-422A terminal block.

* Pins No.7 and No.8 are connected internally to each other and do not have the function as the control lines.

● RS-422A terminal block specifications

- Connected terminal block : RS-422A terminal block (M3 screw)
- Electrical characteristics : Conform to EIA RS-422A
- Connection signals

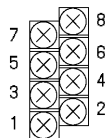

Connector Pin No.	Signal Name	Abbreviation	Signal Direction PT ↔ External Device
1	Functional ground	FG	—
2	Signal ground	SG (GND)	—
3	Send data (+)	SDB	↗
4	Send data (-)	SDA	↗
5	Receive data (+)	RDB	↖
6	Receive data (-)	RDA	↖
7	Request to send (+)	CSB	↖
8	Request to send (-)	CSA	↖

Note: The CSB and CSA signals are for special applications.

INDEX

B

- Bit Allocations 3-9
- Bit and Word Allocations to Bit Devices (M, S, X, Y)
(for Mitsubishi FX) 3-9
- Bit notification
 - for Mitsubishi A computer links 2-18
 - for Mitsubishi FX 3-9
- Bits 2-17
- Bits and Words Allocated to the PC
 - for Mitsubishi A computer links 2-17
 - for Mitsubishi FX 3-8

C

- Clock function
 - for Mitsubishi A computer links 2-18
 - for Mitsubishi FX 3-8
- Computer link 2-2
- Computer Link Module Settings
 - <A0J2-C214S1> 2-12
 - <A1SJ71UC24-R2, A1SJ71C24-R2>
(RS-232C dedicated) 2-15
 - <A1SJ71UC24-R4, A1SJ71C24-R4>
(RS-422 dedicated) 2-16
 - <AJ71C24-S8> 2-13
 - <AJ71UC24> 2-14
- Connection Method (for Mitsubishi FX) 3-4

D

- Direct connection version 1-2

M

- Methods for connection
(for Mitsubishi A computer links)
 - RS-232C (PT)-RS-232C
(Computer Link) 2-5
 - RS-232C (PT)-RS-422A
(Computer Link) 2-6
 - RS-422A (PT)-RS-232C
(Computer Link) 2-8
 - RS-422A (PT)-RS-422A
(Computer Link) 2-7

- Mitsubishi A Series PC Allocation Areas 2-19
- Mitsubishi FX Series PC Allocation Areas 3-11
- Modules Mounted at the Connected PC
 - for Mitsubishi A computer links 2-3
 - for Mitsubishi FX 3-2

P

- Parts for RS-232C (Common to PT and NT-AL001)
 - for Mitsubishi A Computer links 2-4
 - for Mitsubishi FX 3-3
- Parts Required for Connection
 - for Mitsubishi A computer links 2-4
 - for Mitsubishi FX 3-3
- PC Settings
 - for Mitsubishi FX 3-7
- PC that can be connected 1-2
- Possible Combinations 1-2

R

- Recommended Parts for RS-422A Terminal Block
(for NT30/NT30C)
 - for Mitsubishi A Computer links 2-4
- Recommended Parts for RS-422A Terminal Blocks
(for NT-AL001)
 - for Mitsubishi A computer links 2-5
 - for Mitsubishi FX 3-3
- RS-232C connector specifications
 - OMRON PT APP-2
 - NT-AL001 APP-3
- RS-232C/RS-422 Convertor Unit
(NT-AL001) APP-3
- RS-422A terminal block specifications
 - NT30/NT30C only APP-2
 - NT-AL001 APP-3

S

- Screen switching
 - for Mitsubishi A computer links 2-17
 - for Mitsubishi FX 3-8

Setting	
for Mitsubishi A computer links	2-10
for Mitsubishi FX	3-6
Setting for NT-AL001	
for Mitsubishi A computer links	2-11
for Mitsubishi FX	3-7
Specifying memory table numbers	
for Mitsubishi A computer links	2-17
for Mitsubishi FX	3-8
System installer	1-3

U

Usable PT Models	
for Mitsubishi A computer links	2-2
for Mitsubishi FX	3-2

W

Word Allocations	3-10
Word Allocations to Word Devices (D, T, C) (for Mitsubishi FX)	3-10
Words	2-17

Revision History

A manual revision code appears as a suffix to the catalog number on the front cover of the manual.

Cat. No. V042-E1-1

↑
Revision code

The following table outlines the changes made to the manual during each revision. Page numbers refer to the previous version.

Revision code	Date	Revised content
1	April 1997	Original production