



HD30 Series
Vector Control Inverter

HD30 Series

Vector Control Inverter

User Manual



V2.2 2019.03

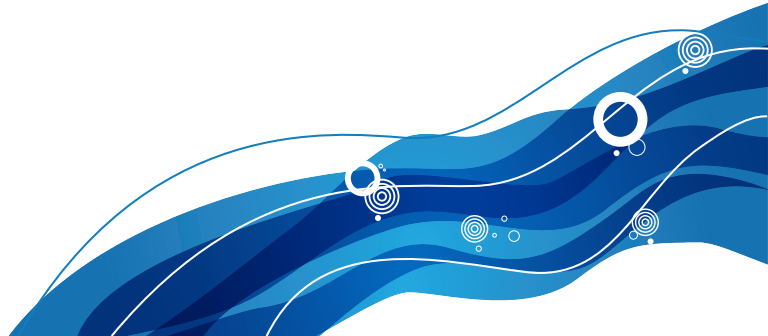

FOREWORD

Thank you for purchasing HD30 series vector control inverter manufactured by Shenzhen Hpmont Technology Co., Ltd.

This User Manual describes how to use HD30 series inverters and their installation wiring, parameter setting, troubleshooting and daily maintenance etc. Before using the product, please read through this User Manual carefully. In addition, please do not use this product until you have fully understood safety precautions.

Note:

- Preserve this Manual for future use.
- If you need the User Manual due to damage, loss or other reasons, please contact the regional distributor of our company or directly contact our company Technical Service Center.
- If you still have some problems during use, please contact our company Technical Service Center.
- Due to product upgrade or specification change, and for the purpose of improving convenience and accuracy of this manual, this manual's contents may be modified.
- Email address: **overseas_1@hpmont.com**

Connection with peripheral devices

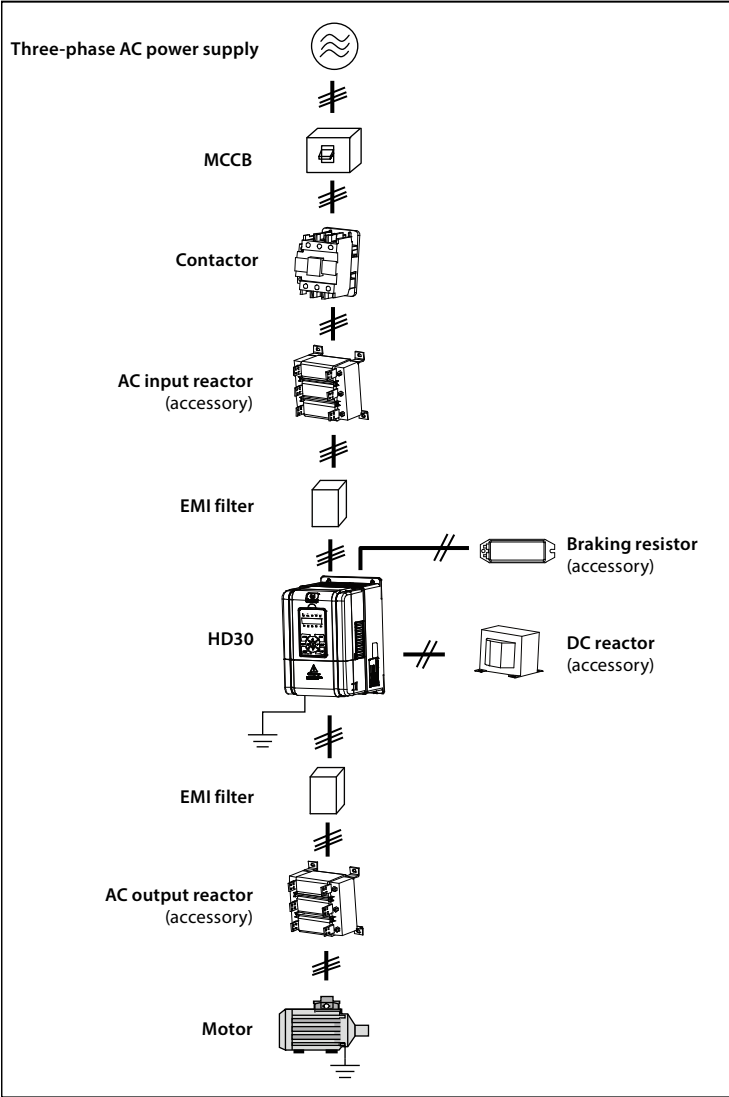

Version and Revision Records

Time: 2019/3

Version: V2.2 (Applicable to software after version 3.09)

Revised chapter	Revised contents
	<ul style="list-style-type: none">• Add three-phase 380V, 450 - 630kW models• Add three-phase 660V, 18.5 - 400kW models<ul style="list-style-type: none">• See section 2.3 for ratings and section 3.4 for dimensions• See section 4.2 for input and output wiring and power terminal wiring• See section 4.3 for power terminals and wiring• See section 4.4.1 for communication terminal description and section 4.4.2 for jumper description• See section 8.5 for braking unit and braking resistor selection and section 8.6 for reactor selection
Chapter 6 Appendix A	<ul style="list-style-type: none">• Modify the factory values of F04.31 (Awaken tolerance) and F04.33 (Sleep tolerance) to: 10.0%• Modify F08.00/F13.01 (motor rated power) setting range to: 0.2 - 9999kW• Modify the setting range of F08.02/F13.03 (motor rated current) to: 0.01 - 250.00A (5.5kW and below) , 0.1 - 2500.0A (5.5kW or more)• Modify the factory value of F09.01/F09.02 (V/f frequency value F3/voltage value V3) to: 80.0%• Modify the factory value of F09.03/F09.04 (V/f frequency value F2/voltage value V2) to: 50.0%

Quick Start for HD30 Operation

Note:

Some parameters have been set (factory setting) so that you could not set for the initial use.

1. Set the motor rating parameter correctly

Power on, use keypad to set the following parameters, motor parameters refer to motor nameplate.

Ref. Code	Function	Ref. Code	Function
F08.00	Rated power of motor 1	F08.03	Rated frequency of motor 1
F08.01	Rated voltage of motor 1	F08.04	Rated RPM of motor 1
F08.02	Rated current of motor 1		

2. Control the start/stop and set the running frequency via using the keypad

1. Power on. Using the keypad can set motor parameters (see the motor nameplate parameter), running frequency and Acc. / Dec. time. See the following table.

Ref. Code	Function	Setting	Meaning
F00.10	Frequency setting source selection	0 (factory setting)	Set by keypad
F00.11	Command setting source selection	0 (factory setting)	Keypad running command channel
F00.13	Starting frequency digital setting	-	Running frequency, adjust according to actual requirement
F03.01	Acc. time 1	-	Acc. time, adjust according to actual requirement
F03.02	Dec. time 1	-	Dec. time, adjust according to actual requirement

2. Pressing panel's **RUN** key can start the inverter, pressing ▲ / ▼ button increase / decrease set frequency, and pressing **STOP** key can stop the inverter outputting.

3. Control the start/stop via terminals and set the running frequency via keypad

1. The terminal DI1 is forward running signal input, and DI2 is reverse running signal input, their wirings are as following figure.

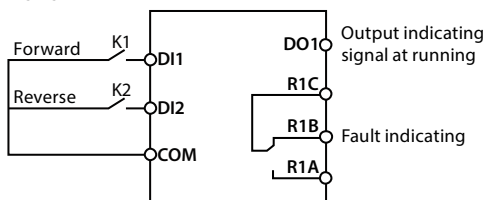

2. After power on, set the functional parameters in accordance with wirings, as following table.

Ref. Code	Function	Setting	Meaning
F00.10	Frequency setting source selection	0 (factory setting)	Set by keypad
F00.11	Command setting source selection	1	Terminal running command source
F00.13	Starting frequency digital setting	-	Running frequency, adjust according to actual requirement
F03.01	Acc. time 1	-	Acc. time, adjust according to actual requirement
F03.02	Dec. time 1	-	Dec. time, adjust according to actual requirement
F15.00	DI1 function	2 (factory setting)	Forward running function (terminal forward signal input)
F15.01	DI2 function	3 (factory setting)	Reverse running function (terminal reverse signal input)

3. When the K1 is closed in the wiring diagram, the motor is running forward; when K1 is turned off, the motor stops running. When the K2 is closed, the motor is running reverse; when K2 is turned off, the motor stops running. K1, K2 are closed or disconnected at the same time, the motor stop running. You can increase / decrease the set frequency by changing F00.13 or pressing the ▲ / ▼ key on the control keypad.

Close the K1 of the wiring diagram, the motor will run forward; close K2, run reverse; simultaneously close or disconnect, the motor will stop.

4. Control the start/stop via terminals and set the running frequency via analogue

1. The terminal DI1 is forward running signal input, and DI2 is reverse running signal input, their wirings are as following figure.

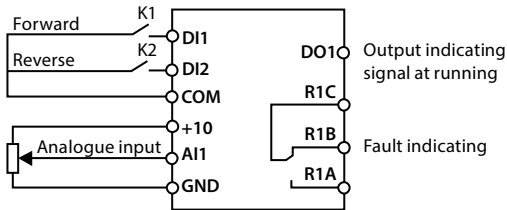

2. After power on, set the functional parameters in accordance with wirings, as following table.

Ref. Code	Function	Setting	Meaning
F00.10	Frequency setting source selection	3	Analogue setting
F00.11	Command setting source selection	1	Terminal running command source
F03.01	Acc. time 1	-	Acc. time, adjust according to actual requirement
F03.02	Dec. time 1	-	Dec. time, adjust according to actual requirement
F15.00	DI1 function	2 (factory setting)	Forward running function (terminal forward signal input)
F15.01	DI2 function	3 (factory setting)	Reverse running function (terminal reverse signal input)
F16.01	AI1 function	2 (factory setting)	Frequency setting source (set by AI1)

3. Set the running frequency by adjusting AI1 analogue input.

4. When the K1 is closed in the wiring diagram, the motor is running forward; when K1 is turned off, the motor stops running. When the K2 is closed, the motor is running reverse; when K2 is turned off, the motor stops running. K1, K2 are closed or disconnected at the same time, the motor stop.

5. Control the start/stop via terminals and set the running frequency via communication

1. The terminal DI1 is forward running signal input, and DI2 is reverse running signal input, their wirings are as following figure.

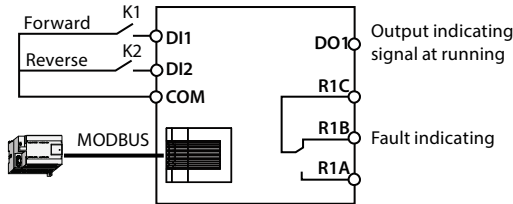

2. After power on, set the functional parameters in accordance with wirings, as following table.

Ref. Code	Function	Setting	Meaning
F00.10	Frequency setting source selection	2	SCI communication setting
F00.11	Command setting source selection	1	Terminal running command source
F03.01	Acc. time 1	-	Acc. time, adjust according to actual requirement
F03.02	Dec. time 1	-	Dec. time, adjust according to actual requirement
F15.00	DI1 function	2 (factory setting)	Forward running function (terminal forward signal input)
F15.01	DI2 function	3 (factory setting)	Reverse running function (terminal reverse signal input)
F15.18	DO1 function	2 (factory setting)	Inverter is running
F17.00	Data format	0 (factory setting)	1-8-2 format, no parity, RTU
F17.01	Baud rate	3 (factory setting)	9600bps
F17.02	Local address	2 (factory setting)	

3. Close the K1 of the wiring diagram, the motor will run forward; close K2, run reverse; simultaneously close or disconnect, the motor will stop.

4. Modify the running frequency via SCI communication function code 0X06 writing register 0x3201. Such as: modify the local address two of slave with running frequency of 45.00Hz, as following table.

Command frame	Address	Code	Register address		Register content		Checksum	
	0x02	0x06	0x32	0x01	0x11	0x94	0xDB	0x7E
Response frame	Address	Code	Register address		Register content		Checksum	
	0x02	0x06	0x32	0x01	0x11	0x94	0xDB	0x7E

6. Control the start/stop and set the running frequency via using communication

1. The communication wirings are as following figure.

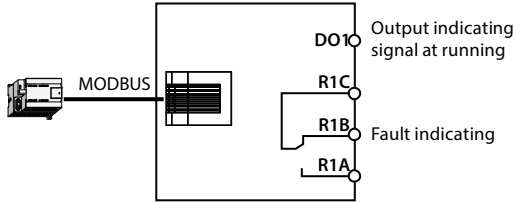

2. After power on, set the functional parameters in accordance with wirings, as following table.

Ref. Code	Function	Setting	Meaning
F00.10	Frequency setting source selection	2	SCI communication setting
F00.11	Command setting source selection	2	SCI communication running command source
F03.01	Acc. time 1	-	Acc. time, adjust according to actual requirement
F03.02	Dec. time 1	-	Dec. time, adjust according to actual requirement
F17.00	Data format	0 (factory setting)	1-8-2 format, no parity, RTU
F17.01	Baud rate	3 (factory setting)	9600bps
F17.02	Local address	2 (factory setting)	

3. Start and stop the local address 2 of inverter via SCI communication function code 0x06 writing register 0x3200, such as forward start command, as following table.

Command frame	Address	Code	Register address		Register content		Checksum	
	0x02	0x06	0x32	0x00	0x10	0x01	0x4B	0x41
Response frame	Address	Code	Register address		Register content		Checksum	
	0x02	0x06	0x32	0x00	0x10	0x01	0x4B	0x41

Dec. stops command, as following table.

Command frame	Address	Code	Register address		Register content		Checksum	
	0x02	0x06	0x32	0x00	0x10	0x04	0x8B	0x42
Response frame	Address	Code	Register address		Register content		Checksum	
	0x02	0x06	0x32	0x00	0x10	0x04	0x8B	0x42

4. Modify the running frequency via SCI communication function code 0X06 writing register 0x3201. Such as: modify the local address two of slave with running frequency of 45.00Hz, as following table.

Command frame	Address	Code	Register address		Register content		Checksum	
	0x02	0x06	0x32	0x01	0x11	0x94	0xDB	0x7E
Response frame	Address	Code	Register address		Register content		Checksum	
	0x02	0x06	0x32	0x01	0x11	0x94	0xDB	0x7E

7. Motor parameter auto-tuning

1. Motor parameter auto-tuning can be only done in keypad mode.
2. Correct wiring.
3. Power on, set motor parameter (F08.00 - F08.04) by keypad.
4. Parameter auto-tuning, available auto-tuning methods for different control mode are shown as below table.

Control Mode	Auto-tuning Method (Recommended)	
V/f control	Manual torque boost Use static, rotary, stator resistance self-tuning	Automatic torque boost Use still, rotate self-tuning
Vector control	Use Rotation Auto Tuning	

Static self-tuning:

F08.06 = 1 (static auto-tuning), press **PRG** key to the stop parameter display state, press **RUN** key to start the auto-tuning. Auto-refresh F08.07 - F08.09 after auto-tuning.

Ref. Code	Function	Ref. Code	Function
F08.07	Motor 1 Stator resistance	F08.09	Motor 1 Leakage inductance
F08.08	Motor 1 rotor resistance		

Rotation Auto-Tuning:

Before turning the auto-tuning, first disconnect the motor from the load.

Then set F08.06 = 2 (Rotate Auto Tuning), press **PRG** key to go to the stop parameter display state, press **RUN** key to start auto tuning.

In the motor rotation process, there may be shock or even overcurrent, this time should immediately press **STOP** key to stop the parameter tuning, and adjust the Acc. and Dec. time and F09.15, F09.16 (suppression shock coefficient) to mitigate possible shocks.

After auto tuning, auto refresh F08.04, F08.07 - F08.16.

Ref. Code	Function	Ref. Code	Function
F08.04	Motor 1 rated Rpm	F08.12	Motor 1 Core saturation coefficient 1
F08.07	Motor 1stator resistance	F08.13	Motor 1 Core saturation coefficient 2
F08.08	Motor 1rotor resistance	F08.14	Motor 1 Core saturation coefficient 3
F08.09	Motor 1 leakage inductance	F08.15	Motor 1 Core saturation coefficient 4
F08.10	Motor 1 Mutual resistance	F08.16	Motor 1 Core saturation coefficient 5
F08.11	Motor 1 No-load excitation current		

Stator resistance measurement:

F08.06 = 3 (only measuring stator resistance), press **PRG** key to stop the shutdown parameter display state, press **RUN** key to start the auto-tuning.

After auto tuning is complete, F08.07 is refreshed automatically.

Ref. Code	Function	Ref. Code	Function
F08.07	Motor 1stator resistance		

CONTENTS

Chapter 1 Safety Information and Precautions	1
1.1 Safety Definition	1
1.2 About Motor and Load.....	1
1.3 About HD30	2
Chapter 2 Product Information	5
2.1 Model	5
2.2 Nameplate.....	5
2.3 Rated Value	6
2.4 Technical Data	8
2.5 Parts of Inverter.....	11
Chapter 3 Mechanical Installation	13
3.1 Precautions	13
3.2 Installation Site Requirement	13
3.3 Installation Direction and Space Requirements	14
3.4 Dimensions and Weight.....	15
3.5 Install and Dismantle Keypad	19
3.6 Dismantle Plastic Cover	20
Chapter 4 Electrical Installation	21
4.1 Wiring Precautions.....	21
4.2 Peripheral Accessories Selection.....	21
4.2.1 Wiring specifications of input and output.....	21
4.2.2 Power terminal lug	24
4.3 Main Circuit Terminals and Wiring	24
4.3.1 Supply and Motor Terminal	25
4.3.2 Power Terminal Wiring.....	29
4.4 Control Board	32
4.4.1 Communication Terminal	32
4.4.2 Jumper	33
4.4.3 Control Board Terminal	34
4.4.4 Control Terminal Wiring	35
4.5 Meet EMC Requirement of Installation	38
4.5.1 Correct EMC Installation	38
4.5.2 Wiring Requirement	39
4.5.3 Motor Connection.....	39



4.5.4 Ground Connection.....	40
4.5.5 EMI Filter.....	40
4.5.6 Countermeasures for Conduction, Radiation and Radio Frequency Interference.....	41
4.5.7 Reactor.....	41
Chapter 5 Operation Instructions.....	43
5.1 Function Description.....	43
5.1.1 Operation Mode.....	43
5.1.2 Inverter Frequency Setting Source.....	43
5.1.3 Inverter Status.....	44
5.1.4 Inverter Running Mode.....	44
5.2 Operating Instructions.....	45
5.2.1 Keypad.....	45
5.2.2 Display Status.....	46
5.2.3 Keypad Operation Examples.....	48
5.3 Initial Power On.....	52
Chapter 6 Function Introduction.....	53
6.1 Group d: Display Parameters.....	54
6.1.1 d00: Status Display Parameters.....	54
6.2 Group F: General Function Parameters.....	57
6.2.1 F00: Basic Parameters.....	57
6.2.2 F01: Protection of Parameters.....	62
6.2.3 F02: Run / Stop Control Parameters.....	63
6.2.4 F03: Acc. / Dec. Parameters.....	66
6.2.5 F04: Process PID Control.....	67
6.2.6 F05: External Reference Curve Parameters.....	70
6.2.7 F06: MS SPEED and Simple PLC.....	72
6.2.8 F07: Wobble Operation Parameters.....	75
6.2.9 F08: Asyn. Motor 1 Parameters.....	76
6.2.10 F09: V/f Control Parameters.....	78
6.2.11 F10: Motor 1 Vector Control Speed-loop Parameters.....	80
6.2.12 F11: Motor 1 Vector Control Current Loop Parameter.....	81
6.2.13 F13: Asyn. Motor 2 Parameters.....	82
6.2.14 F15: Digital I/O Terminal Parameters.....	85
6.2.15 F16: Analogue I/O Terminal Parameters.....	97
6.2.16 F17: SCI Communication Parameters.....	101
6.2.17 F18: Display Control Parameters.....	102
6.2.18 F19: Function-boost Parameters.....	103

6.2.19 F20: Protection of Fault Parameters	111
6.2.20 F21: Torque Control Parameters	115
6.2.21 F23: PWM Control Parameters.....	116
6.3 Group U: User Menu Mode Display Parameters	117
6.4 Group y: Manufacturer Function Parameters	117
Chapter 7 Troubleshooting and Maintenance	119
7.1 Troubleshooting.....	119
7.2 Maintenance.....	122
Chapter 8 Options.....	125
8.1 HD30-EIO.....	125
8.2 HD30-PIO.....	127
8.3 Keypad Installation Assembly	128
8.4 Power Regenerative Unit.....	128
8.5 Braking Unit and Braking Resistor	129
8.6 Reactor Selection.....	132
Appendix A Quick Start for User Menu of Group U	135
Appendix B Parameters.....	136
Appendix C Communication Protocol	177

Safety Information and Precaution	1
Product Information	2
Mechanical Installation	3
Electrical Installation	4
Operation Instructions	5
Function Introduction	6
Troubleshooting and Maintenance	7
Options	8
Quick Start for User Menu of Group U	A
Parameters	B
Communication Protocol	C

Chapter 1 Safety Information and Precautions

1.1 Safety Definition

 Danger	1
Danger: A Danger contains information which is critical for avoiding safety hazard.	
 Warning	
Warning: A Warning contains information which is essential for avoiding a risk of damage to products or other equipments.	
<u>Note</u>	
Note: A Note contains information which helps to ensure correct operation of the product.	

1.2 About Motor and Load

Compared to the standard frequency operation

The HD30 series inverters are voltage-type frequency inverter and their output is PWM wave with certain harmonic wave. Therefore, the temperature, noise and vibration of the motor will be a little higher than that at standard frequency operation.

Constant torque at low-speed operation

When the inverter drives a standard motor at low-speed running for a long time, the output torque ratings will become worse due to the motor cooling is less effective. In that case, we suggest that you should choose variable frequency motor.

Motor's overload protecting threshold

When choose the adaptive motor, the inverter can effectively implement the motor thermal protection. Otherwise it must adjust the motor protection parameters or other protection measures to ensure that the motor is at a safe and reliable operation.

Operation above the motor rated frequency

If the motor exceeds its rated frequency operation, the noise will increase. It need play attention to the motor vibration as well as ensure the motor bearings and mechanical devices to meet the requirement of operation speed range.

Lubrication of mechanical devices

At long time low-speed operation, it should provide periodical lubrication maintenance for the mechanical devices such as gear box and geared motor etc. to make sure the drive results meet the site need.

Mechanical resonance point of load

By setting the skip frequency of the inverter (F05.17 - F05.19) to avoid the load device or the motor mechanical resonance point.

Check the insulation of the motor

For the first time using of the motor or after long time storage, it need check the insulation of the motor to avoid damage the inverter because of the worse insulation motor.

Note:

Please use a 500V Mega-Ohm-Meter to test and the insulation resistance must be higher than 5Mohm.

Energy feedbacks to inverter

For the occasion to boost load and the like, negative torque often occurs. You should consider setting proper parameters of the braking unit if the inverter is prone to overcurrent or overvoltage fault trip.

Requirement for leakage current protector RCD

Since the device generates high leakage current which goes through the protective grounding conductor, please install B type leakage current protector RCD on one side of the power supply.

For the selection of RCD, users need to consider the possible problems of ground leakage current in both transient status and steady status at start and during running. It is recommended to choose either special RCD that can suppress the higher harmonics, or general RCD that has more aftercurrent.

Warning for ground mass leakage current

The device generates mass leakage current, so users need to confirm the reliable grounding before connect to the power supply. The grounding should comply with the local relative IEC standard.

1.3 About HD30

No capacitor or varistor on the output side

Since the inverter output is PWM wave, it is strictly forbidden to connect capacitor for improving the power factor or varistor for lightning protection to the output terminals so as to avoid the inverter fault tripping or component damage.

Contactors and circuit breakers connected to the output of the inverter

If circuit breaker or contactor needs to be connected between the inverter and the motor, be sure to operate these circuit breakers or contactor when the inverter has no output, so as to avoid any damage to the inverter.

Running voltage

The inverter is prohibited to be used beyond the specified range of operation voltage. If needed, please use the suitable voltage regulation device to change the voltage.

Capacitor energy storage

When the AC power supply is cut off, capacitor of HD30 sustains deadly power for a while. So to disassemble HD30 that is powered, please cut off the AC power supply for more than 10 minutes, confirm the internal charge indicator is off and the voltage between (+) and (-) of the main circuit terminals is below 36V.

Generally, the internal circuit enables the capacitor to discharge. However, the discharging may fail in some exceptions. In these cases, users need to consult Hpmont or our regional distributor.

1

Change three-phase input to single-phase input

For three-phase input inverter, the users should not change it to single-phase input.

If you have to use single-phase power supply, you should disable the input phase-loss protection function. And the bus-voltage and current ripple will increase, which not only influences the life of electrolytic capacitor but also deteriorates the performance of the inverter. In that case, the inverter must be derating and should be within the inverter 60% rated value.

Lightning surge protection

The inverter internal design has lightning surge overcurrent protection circuit, and has certain self-protection capacity against the lightning.

Altitude and derating

In area where altitude exceeds 1000 meters, HD30 should be derating since the heatsink efficiency will be reduced because of the tenuous air.

The rated value of output current derates by 1% for each 100m increase of the altitude. I.e for the altitude of 3000m, derated rate is 20% for rated current of HD30. Figure 1-1 is the derating curve of rated current and the altitude.

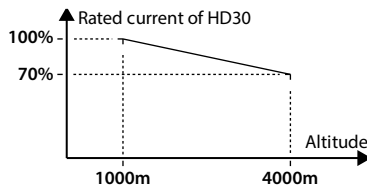
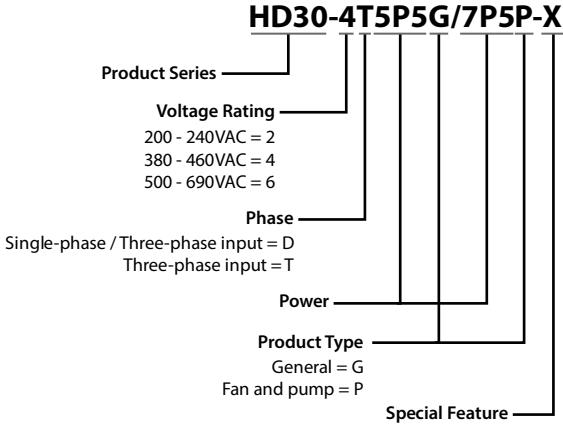

Figure 1-1 Derating curve of rated current and altitude

Chapter 2 Product Information

2.1 Model



2.2 Nameplate

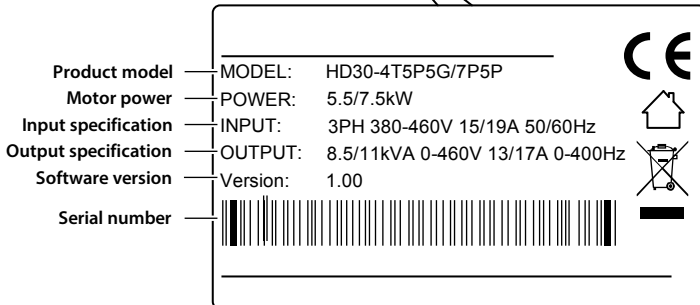
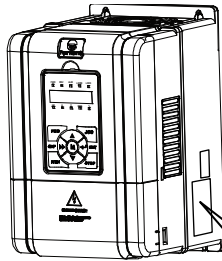

2.3 Rated Value

Refer to section 3.4 Dimensions and Weight (on page 15) for size information.

Model	Motor (kW)	Rated capacity (kVA)	Rated input current (A)	Rated output current (A)	Size
-------	---------------	-------------------------	----------------------------	-----------------------------	------

Single/three-phase power supply: 200 - 240V, 50/60Hz

HD30-2D0P4G	0.4	1.0	5.8 / 2.7 ⁽¹⁾	2.5	Frame 1
HD30-2D0P7G	0.75	1.5	10.5 / 4.2 ⁽¹⁾	4.0	Frame 1
HD30-2D1P5G	1.5	2.8	18.5 / 7.7 ⁽¹⁾	7.5	Frame 1
HD30-2D2P2G	2.2	3.8	24.1 / 12 ⁽¹⁾	10	Frame 1
HD30-2D3P7G	3.7	5.9	40 / 19 ⁽¹⁾	17	Frame 2
HD30-2D5P5G	5.5	8.5	60 / 28 ⁽¹⁾	25	Frame 3
HD30-2D7P5G	7.5	11	75 / 35 ⁽¹⁾	32	Frame 3
HD30-2D011G	11	16	100 / 47 ⁽¹⁾	45	Frame 4
HD30-2D015G	15	21	130 / 62 ⁽¹⁾	55	Frame 5A

(1): Value before / is for single-phase model, value after / is for three-phase model.

Three-phase power supply: 200 - 240V, 50/60Hz

HD30-2T018G	18.5	24	77	70	Frame 5
HD30-2T022G	22	30	92	80	Frame 6
HD30-2T030G	30	39	113	110	Frame 6
HD30-2T037G	37	49	156	130	Frame 6
HD30-2T045G	45	59	180	160	Frame 7
HD30-2T055G	55	72	214	200	Frame 7
HD30-2T075G	75	100	256	253	Frame 7

Three-phase power supply: 380 - 460V, 50/60Hz

HD30-4T0P7G	0.75	1.5	3.4	2.3	Frame 1
HD30-4T1P5G	1.5	2.5	5.2	3.8	Frame 1
HD30-4T2P2G	2.2	3.4	7.3	5.1	Frame 1
HD30-4T3P7G/5P5P	3.7/5.5	5.9/8.5	11.9/15	9.0/13	Frame 2
HD30-4T5P5G/7P5P	5.5/7.5	8.5/11	15/19	13/17	Frame 2
HD30-4T7P5G/011P	7.5/11	11/16	19/28	17/25	Frame 3
HD30-4T011G/015P	11/15	16/21	28/35	25/32	Frame 3
HD30-4T015G/018P	15/18.5	21/24	35/39	32/37	Frame 4
HD30-4T018G/022P	18.5/22	24/30	39/47	37/45	Frame 4
HD30-4T022G/030P	22/30	30/39	47/62	45/60	Frame 5
HD30-4T030G/037P	30/37	39/49	62/77	60/75	Frame 5
HD30-4T037G/045P	37/45	49/59	77/92	75/90	Frame 6
HD30-4T045G/055P	45/55	59/72	92/113	90/110	Frame 6
HD30-4T055G/075P	55/75	72/100	113/156	110/152	Frame 6
HD30-4T075G/090P	75/90	100/116	156/180	152/176	Frame 7
HD30-4T090G/110P	90/110	116/138	180/214	176/210	Frame 7
HD30-4T110G/132P	110/132	138/167	214/256	210/253	Frame 7

Model	Motor (kW)	Rated capacity (kVA)	Rated input current (A)	Rated output current (A)	Size
HD30-4T132G/160P HD30-4T132G/160P-C	132/160	167/200	256/307	253/304	Frame 8
HD30-4T160G/200P HD30-4T160G/200P-C	160/200	200/250	307/385	304/380	Frame 8
HD30-4T200G/220P HD30-4T200G/220P-C	200/220	250/280	385/430	380/426	Frame 8
HD30-4T220G/250P HD30-4T220G/250P-C	220/250	280/309	430/475	426/470	Frame 9
HD30-4T250G/280P HD30-4T250G/280P-C	250/280	309/349	475/535	470/530	Frame 9
HD30-4T280G/315P HD30-4T280G/315P-C	280/315	349/398	535/609	530/600	Frame 9
HD30-4T315G/355P HD30-4T315G/355P-C	315/355	398/434	609/664	600/660	Frame 10
HD30-4T355G/400P HD30-4T355G/400P-C	355/400	434/494	664/754	660/750	Frame 10
HD30-4T400G/450P HD30-4T400G/450P-C	400/450	494/560	754/852	750/830	Frame 10
HD30-4T450G/500P HD30-4T450G/500P-C	450/500	560/592	852/930	830/900	Frame 10
HD30-4T500G	500	592	930	900	Frame 11
HD30-4T560G	560	658	1030	1000	Frame 11
HD30-4T630G	630	724	1130	1100	Frame 11

Three-phase power supply: 500 - 690V, 50/60Hz

HD30-6T018G	18.5	24	26	22	Frame 12
HD30-6T022G	22	30	33	27	Frame 12
HD30-6T030G	30	39	39	36	Frame 12
HD30-6T037G	37	49	46	43	Frame 12
HD30-6T045G	45	59	55	52	Frame 12
HD30-6T055G	55	72	75	63	Frame 12
HD30-6T075G	75	100	89	85	Frame 13
HD30-6T090G	90	116	128	100	Frame 13
HD30-6T110G	110	138	144	125	Frame 13
HD30-6T132G	132	167	170	144	Frame 14
HD30-6T160G	160	200	200	175	Frame 14
HD30-6T200G	200	250	235	215	Frame 14
HD30-6T220G	220	280	247	245	Frame 15
HD30-6T250G	250	309	265	260	Frame 15
HD30-6T280G	280	349	305	299	Frame 15
HD30-6T315G	315	398	350	330	Frame 15
HD30-6T355G	355	434	382	374	Frame 16

Model	Motor (kW)	Rated capacity (kVA)	Rated input current (A)	Rated output current (A)	Size
HD30-6T400G	400	494	435	410	Frame 16

2.4 Technical Data

Electrical	
Input voltage	Single/three-phase: 200 - 240V Three-phase: 380 - 460V Three-phase: 500 - 690V Fluctuating within $\pm 10\%$, unbalance rate $< 3\%$
Input frequency	50/60Hz $\pm 5\%$
Output voltage	0 - input voltage
Output frequency	0 - 400.00Hz
Performance	
Max. current	G: 150% rated output current for 2 minutes, 180% rated output current for 10 seconds P: 130% rated output current for 1 minutes, 150% rated output current for 10 seconds
Control mode	V/f, SVC
Running command	Keypad; Terminal; SCI communication
Speed setting	Digital; Analogue / pulse; SCI communication
Speed resolution	Digital setting: 0.01Hz Analogue setting: $0.1\% \times \text{max-frequency}$
Speed control accuracy	SVC: $\pm 0.5\%$
Speed control range	SVC: 1:100
Torque control response	SVC: $< 200\text{ms}$
Start torque	SVC: 180% rated torque / 0.5Hz
Torque control accuracy	$\pm 5\%$
Characteristic Functions	
User custom menu	A total of 16 user-defined mapping, the user can edit
Parameter upload and download function	You can achieve two sets of parameters from the inverter control keypad copied to the control keypad and copied from the operation keypad to the inverter control keypad
Programmable I/O terminals	Input terminal function can be edited and output terminal function can be edited
Process PID adjustment	Internal process PID module
Simple PLC	To achieve time and multi-frequency output with internal simple PLC module
Wobble operation	Internal wobble operation module
Length control	Internal length control module
Compatible with a variety of communication protocols	Standard MODBUS communication protocol. The optional PROFIBUS bus module is compatible with the PROFIBUS protocol; Optional DeviceNet bus module is compatible with DeviceNet protocol; Optional CAN bus module is compatible with CAN communication protocol

Protection Functions	
Stall overvoltage	Bus voltage can auto-control against overvoltage fault
Auto-limited current protection	Output current can auto-limit against overcurrent fault
Overload pre-alarm and alarm	Overload early pre-alarm and protect
Load loss protection	Load loss alarm function
I/O phase loss protection	I/O phase loss auto-detect and alarm function
Braking fault protection	Braking detection and alarming function
Power output grounding fault protection	Power output grounding fault protection is enabled
Power output grounding fault protection	Power output grounding fault protection is enabled
Power output short circuit protection	Power output short circuit protection is enabled
Input / Output	
Analogue power supply	+10V, max. current 100mA
Digital supply	+24V, max. current 200mA
Analogue input	AI1: voltage 0 - 10V AI2: -10V - +10V/0 - 20mA (selectable voltage/current) <i>Optional HD30-EIO expansion card can be extended to 4 road</i>
Analogue output	AO1, AO2: 0 - 10V/0 - 20mA (selectable voltage/current)
Digital input	DI1 - DI6, DI6 can be selected as high - speed pulse signal <i>Optional HD30-EIO expansion card can be extended to 9</i>
Digital output	DO1, DO2, DO2 can be selected as high frequency pulse signal output
Programmable relay output	R1A/R1B/R1C: Contact rating 250VAC/3A or 30VDC/1A <i>Optional HD30-EIO expansion card can be extended to 4</i>
SCI communication	RJ45 interface, A,B terminal
Keypad	
LED display	Five LEDs display Setting frequency, output frequency, output voltage, output current, motor speed, output torque, switching value terminal, status parameter, programm menu parameter and fault code etc.
LCD display	Optional (HD-LCD), display operation contents in Chinese or English
Parameter copy	Both LED and LCD keypad can achieve quick parameter copy
Indicator	5 unit indicators, 5 status indicators

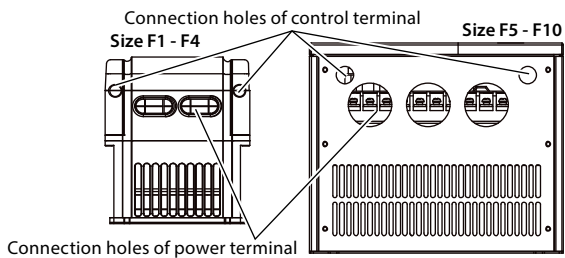
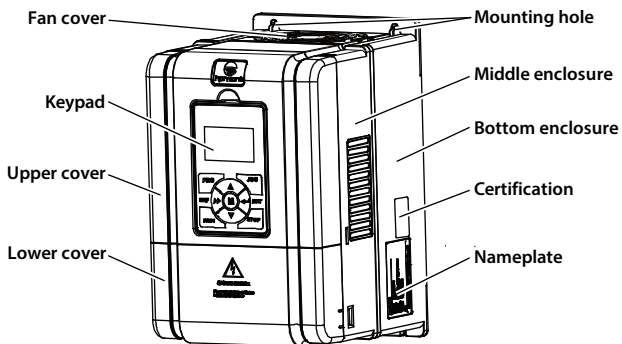

Environment	
Running temperature	-10 - +40°C, max. 50°C, air temperature fluctuation is less than 0.5°C/min The derating value of output current of HD30 shall be 2% for each degree centigrade above 40°C. Max. allowed temperature is 50°C
Storage temperature	-40 - +70°C
Location for use	Indoor, preventing from direct sunlight, no dust, corrosive, flammable gases, oil mist, water vapor, dripping or salt etc.
Altitude	Less than 1000 meters, otherwise should be derating use
Humidity	Less than 95%RH, non-condensing
Vibration Resistance	It is 3.5m/s ² in 2 - 9Hz, it is 10m/s ² (IEC60721-3-3) in 9 - 200Hz
Protection Class	IP20
Pollution level	Level 2 (Dry, non conducting dust pollution)
Accessories	
I/O board	HD30-EIO, HD30-PIO
Bus communication	PROFIBUS option [HDFB-PROFIBUS-DP] DeviceNet option [HDFB-DeviceNet] CAN option [HDFB-CAN]
About keypad	Status keypad [HD-LED-L] Small-size keypad [HD-LED-P-S] LED display pane with potentiometer [HD-LED-P] LCD keypad [HD-LCD] Mounting base to keypad [HD-KMB] Small-size external mounting base [HD-KMB-S] 1m/2m/3m/6m extension cable to keypad [HD-CAB-1M/2M/3M/6M]
Power unit	Dynamic braking unit [HDBU] Power regenerative unit [HDRU]

2.5 Parts of Inverter



Chapter 3 Mechanical Installation

3.1 Precautions

 Danger
<ul style="list-style-type: none"> • Do not install if HD30 is incomplete or impaired. • Please see the controller size and weight to take appropriate tools for handling, avoid harming from sharp edges or injured by a dropped controller. • Make sure that HD30 is far from the explosive and flammable things. • Do not do wiring operation until power supply is cut off for more than 10 minutes, the internal charge indicator of HD30 is off and the voltage between (+) and (-) of the main circuit terminals is below 36V.
 Warning
<ul style="list-style-type: none"> • It is required not only carry the keypad and the cover but also the inverter bottom enclosure. • Do not play metal into the inverter when installing.

3

3.2 Installation Site Requirement

Ensure the installation site meets the following requirements:

- Do not install at the direct sunlight, moisture, water droplet location;
- Do not install at flammable, explosive, corrosive gas and liquid location;
- Do not install at oily dust, fiber and metal powder location;
- Be vertical installed on fire-retardant material with a strong support;
- Make sure adequate cooling space for HD30 so as to keep ambient temperature between - 10 - + 40°C;
- Install at where the vibration is 3.5m/s² in 2 - 9Hz, 10m/s² in 9 - 200Hz (IEC60721-3-3);
- Install at where the humidity is less than 95%RH and non-condensing location;
- Protection level of HD30 is IP20 and pollution level is 2 (Dry, non-conducting dust pollution).

Note:

1. It needs derating use running temperature exceeds 40 °C. The derating value of the output current of HD30 shall be 2% for each degree centigrade. Max. allowed temperature is 50 °C.
2. Keep ambient temperature between -10 - +40 °C. It can improve the running performance if install at location with good ventilation or cooling devices.

3.3 Installation Direction and Space Requirements

To achieve good cooling efficiency, install the inverter perpendicularly and always provide the following space to allow normal heat dissipation. The requirements on mounting space and clearance are shown in Table 3-1.

Table 3-1 Inverter installation space size table

HD30 power	≤ 55kW	≥ 75kW
A (left and right)	≥ 50mm	≥ 150mm
B (up and down)	≥ 100mm	≥ 350mm
C (up vent)	≥ 50mm	≥ 100mm
D (down vent)	≥ 50mm	≥ 100mm

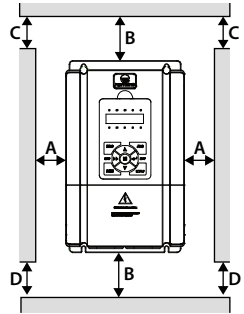

More than one inverter with the installation of the upper and lower, the middle should be installed with diversion partitions, installation space size see Table 3-2.

Table 3-2 Multi-inverters changer installation space dimension

HD30 power	≤ 55kW	≥ 75kW
A	≥ 50mm	≥ 100mm
B	≥ 50mm	≥ 100mm
C	≥ 50mm	≥ 100mm
a	≥ 50mm	≥ 100mm
b	≥ 50mm	≥ 100mm
c	≥ 50mm	≥ 100mm

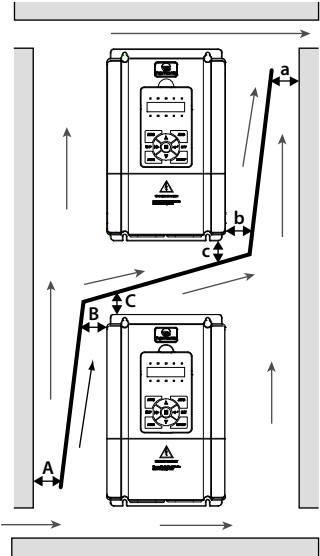

3.4 Dimensions and Weight

The dimensions and weight of HD30 are as shown in Table 3-3 and Table 3-4.

For the corresponding model of the mounting size, please refer to section 2.3 Rated Value, on page 6.

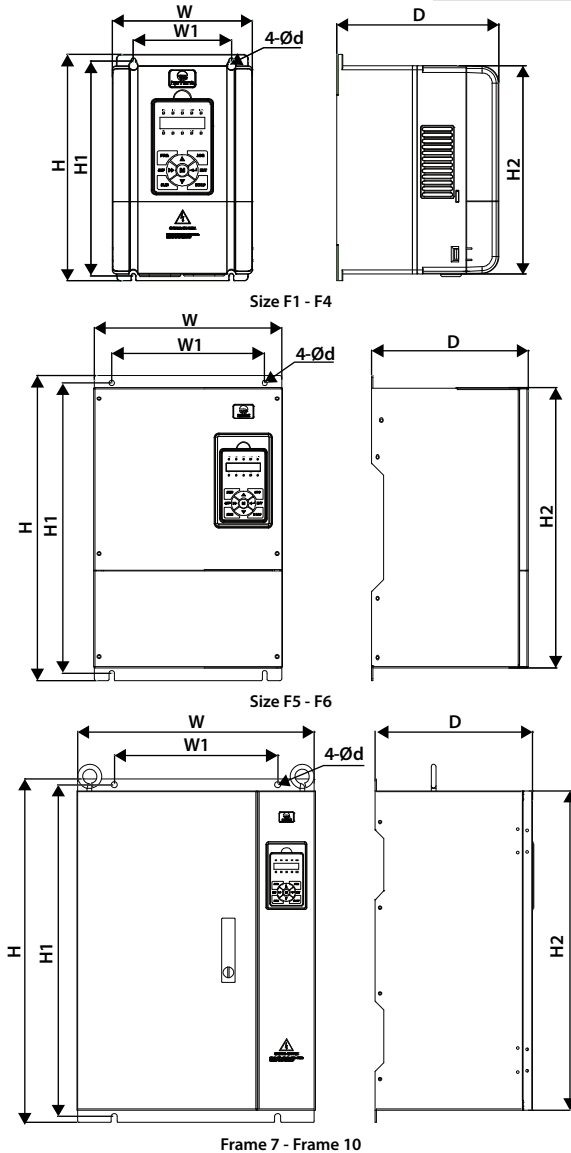

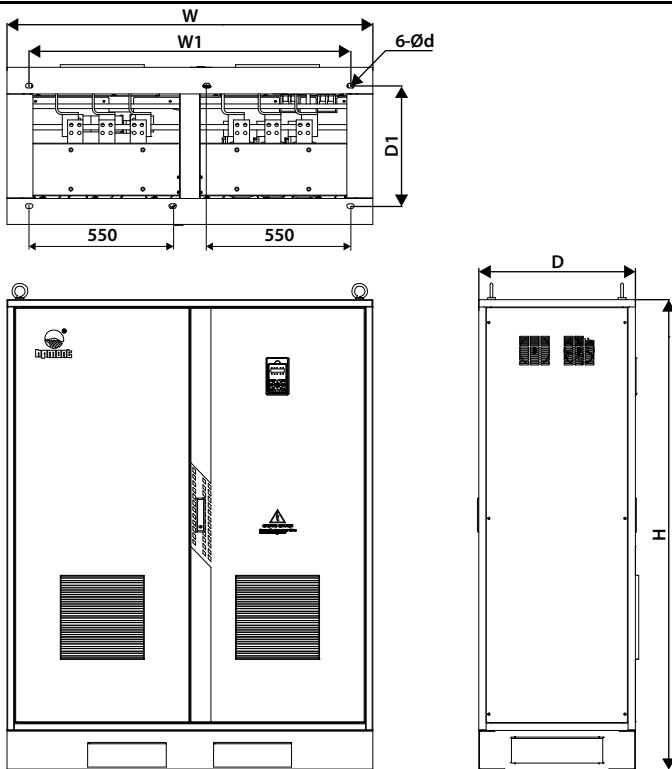

Frame 11

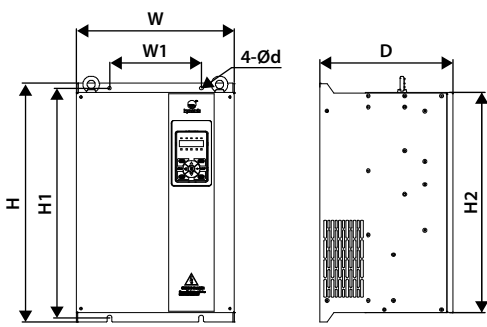

Frame 12 - Frame 14

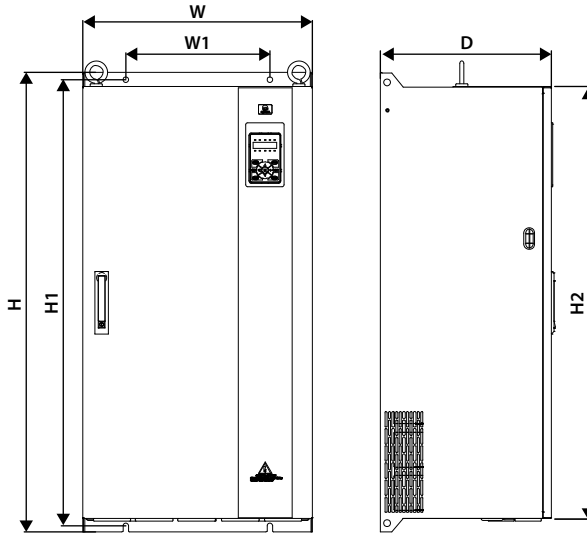

Frame 15 - Frame 16

Table 3-3 HD30 dimensions and weight

Size	Dimension (mm)			Mounting Size (mm)				GW (kg)
	W	H	D	W1	H1	H2	d	
Frame 1	135	241	162	91	226	220	5	2.4
Frame 2	165	266	190	115	253	245	5	4.4
Frame 3	200	299	210	146	286	280	5	5.8
Frame 4	235	353	222	167	337	330	7	8.2
Frame 5	290	469	240	235	448	430	8	20.4
Frame 5 A	295	448	205	235	432	418	7	19.5
Frame 6	380	598	290	260	576	550	10	48
Frame 7	500	721	330	343	696	670	12	80
Frame 8	620	917	360	450	890	850	12	115
Frame 9	740	1067	370	520	1040	1000	14	150
Frame 10	970	1316	380	620	1286	1250	14	190
Frame 12	345	520	290	200	500	480	8	30
Frame 13	415	650	360	320	626	600	10	55
Frame 14	415	710	380	320	686	660	12	75
Frame 15	510	1020	380	320	992	960	12	120
Frame 16	620	1050	395	520	1020	977	14	150

Size	Dimension (mm)			Mounting Size (mm)		
	W	H	D	W1	D1	d
Frame 11	1400	1800	600	1230	460	18*28

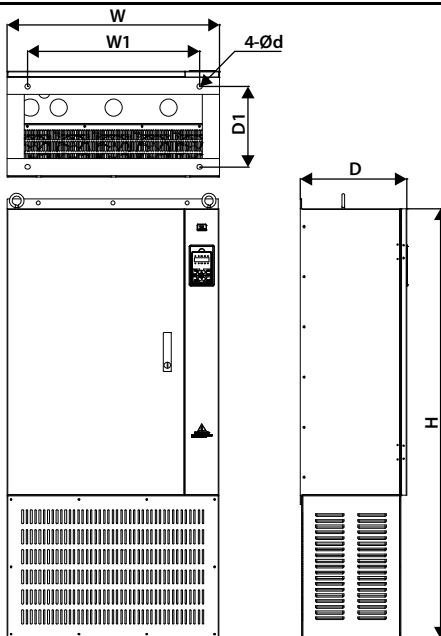

Figure 3-1 HD30 cabinet

Table 3-4 HD30 cabinet dimension

Size (-C)	Dimension (mm)			Mounting Size (mm)		
	W	H	D	W1	D1	d
Frame 8	620	1250	360	500	270	18
Frame 9	740	1500	370	600	280	18
Frame 10	970	1650	380	700	280	18

3.5 Install and Dismantle Keypad

According to the direction of Figure 3-2, press the keypad until hear a “click” sound.

Do not install the keypad from other directions or it will cause poor contact.

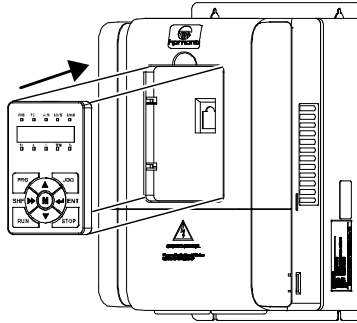

Figure 3-2 Install keypad

There are two steps in Figure 3-3.

First, press the hook of the keypad according to direction 1. Second, take out of the keypad according to direction 2.

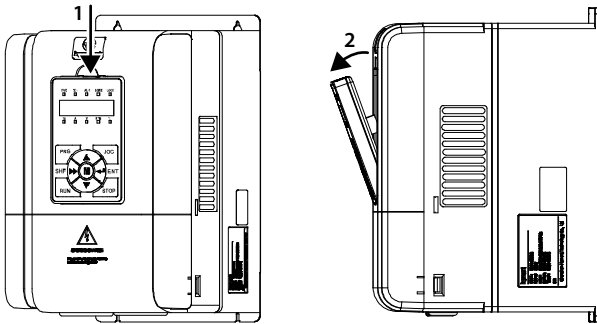
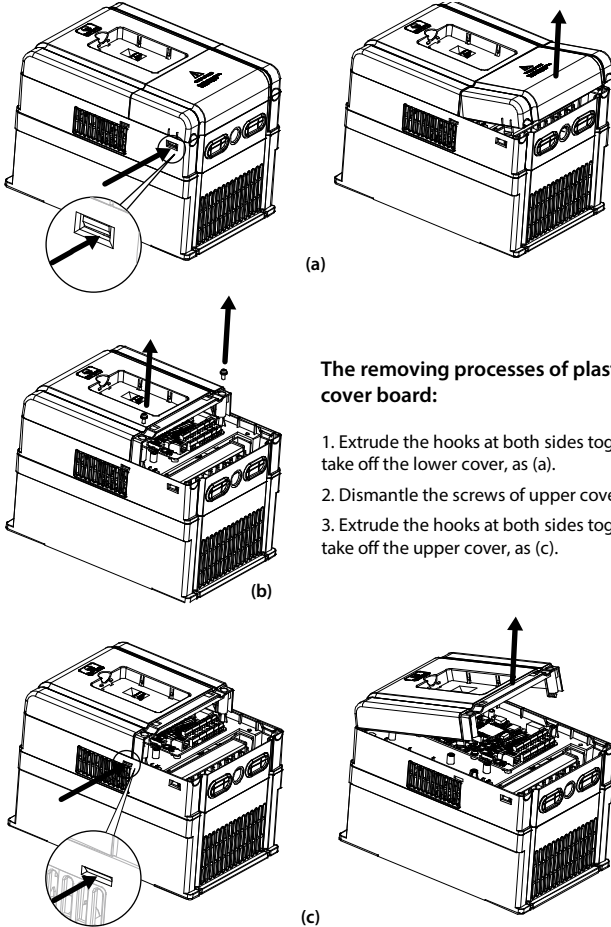

Figure 3-3 Dismantle keypad

3.6 Dismantle Plastic Cover

The upper cover and the lower cover of the HD30 series inverter are removable. The dismantle step is shown as Figure 3-4.

Before removing the upper cover, please take away the keypad.



The removing processes of plastic cover board:

1. Extrude the hooks at both sides together, take off the lower cover, as (a).
2. Dismantle the screws of upper cover, as (b).
3. Extrude the hooks at both sides together, take off the upper cover, as (c).

Figure 3-4 Dismantle of the plastic cover

Chapter 4 Electrical Installation

4.1 Wiring Precautions

 Danger
<ul style="list-style-type: none"> • Only qualified electrical engineer can perform wiring job. • To facilitate the input side over-current protection and outage maintenance, connect HD30 with power supply via the MCCB or fuse. • Do not dismantle HD30 or do wiring operation until the power is cut-off for more than 10 minutes, the internal charge indicator of HD30 is off and the voltage between (+) and (-) of the main circuit terminals is below 36V. • Check the wiring carefully before connecting emergency stop or safety circuit. • There is more than 3mA leakage current in HD30 grounding, depending on the running conditions. To ensure safety, HD30 and the motor must connect to separate and independent grounding wire, so as to ground reliably. It must use Type B mode when utilize ground leakage protection devices (ELCB/RCD). • Do not touch the wire terminals of HD30 when it is live. The main circuit terminals are neither allowed connecting to the enclosure nor short-circuiting.

4

 Warning
<ul style="list-style-type: none"> • Do not do dielectric strength test on HD30. • For HD30 with more than 2 year's storage, please use regulator to power it slowly. • Do wiring connection of the braking resistor or the braking unit according to the wiring figure. • Make sure the terminals are fixed tightly. • Do not connect the AC supply cable to the output terminals U/V/W of HD30. • Do not connect the phase-shifting capacitors to the output circuit. • Be sure HD30 has ceased output before switching motor or change-over switches. • The DC bus terminals of HD30 must not be short-circuited.

4.2 Peripheral Accessories Selection

4.2.1 Wiring specifications of input and output

The AC supply to HD30 must be installed with suitable protection against overload and short-circuits, i.e. MCCB (molded case circuit breaker) or equivalent device.

The recommended specification of MCCB, contactor & cables are shown as Table 4-2.

The size of ground wire should accord with the requirement in 4.3.5.4 of IEC61800-5-1, as shown in Table 4-1.

Table 4-1 Sectional area of ground protective conductor

Sectional area S of phase conductor (power supply cable) while installing (mm ²)	$S \leq 2.5$	$2.5 < S \leq 16$	$16 < S \leq 35$	$S > 35$
Min. sectional area Sp of relative protective conductor (ground cable) (mm ²)	2.5	S	16	S/2

Table 4-2 HD30 I/O wiring specification

Model	MCCB (A)	Contactor (A)	Supply Cable (mm ²)	Motor Cable (mm ²)	Ground Cable (mm ²)	Size
Single/three phase: 200 - 240V, 50/60Hz						
HD30-2D0P4G	16	10	0.5	0.5	2.5	Frame 1
HD30-2D0P7G	16	10	0.75 / 0.5 ⁽¹⁾	0.5	2.5	Frame 1
HD30-2D1P5G	20	16	4 / 0.75 ⁽¹⁾	0.8	4 / 2.5 ⁽¹⁾	Frame 1
HD30-2D2P2G	32	20	6 / 2.5 ⁽¹⁾	1.5	6 / 2.5 ⁽¹⁾	Frame 1
HD30-2D3P7G	100 / 40 ⁽¹⁾	63 / 32 ⁽¹⁾	10 / 4 ⁽¹⁾	4	10 / 4 ⁽¹⁾	Frame 2
HD30-2D5P5G	125 / 63 ⁽¹⁾	100 / 40 ⁽¹⁾	25 / 6 ⁽¹⁾	6	16 / 6 ⁽¹⁾	Frame 3
HD30-2D7P5G	160 / 63 ⁽¹⁾	100 / 40 ⁽¹⁾	25 / 10 ⁽¹⁾	10	16 / 10 ⁽¹⁾	Frame 3
HD30-2D011G	200 / 100 ⁽¹⁾	125 / 63 ⁽¹⁾	25 / 16 ⁽¹⁾	16	16	Frame 4
HD30-2D015G	200 / 125 ⁽¹⁾	160 / 100 ⁽¹⁾	50 / 25 ⁽¹⁾	16	25 / 16 ⁽¹⁾	Frame 5A
<i>(1): Value before / is for single-phase model, value after / is for three-phase model.</i>						
Three phase: 200 - 240V, 50/60Hz						
HD30-2T018G	160	100	25	25	16	Frame 5
HD30-2T022G	200	125	35	35	16	Frame 6
HD30-2T030G	200	125	35	35	16	Frame 6
HD30-2T037G	250	160	50	50	25	Frame 6
HD30-2T045G	250	160	95	70	50	Frame 7
HD30-2T055G	350	350	95	95	50	Frame 7
HD30-2T075G	400	400	120	120	50	Frame 7
Three phase: 380 - 460V, 50/60Hz						
HD30-4T0P7G	10	10	0.5	0.5	2.5	Frame 1
HD30-4T1P5G	16	10	0.75	0.5	2.5	Frame 1
HD30-4T2P2G	16	10	1.5	0.75	2.5	Frame 1
HD30-4T3P7G/5P5P	25	16	2.5	2.5	2.5	Frame 2
HD30-4T5P5G/7P5P	32	25	4	4	4	Frame 2
HD30-4T7P5G/011P	40	32	6	6	6	Frame 3
HD30-4T011G/015P	63	40	10	10	10	Frame 3
HD30-4T015G/018P	63	40	10	10	10	Frame 4
HD30-4T018G/022P	100	63	16	16	16	Frame 4
HD30-4T022G/030P	100	63	25	25	16	Frame 5
HD30-4T030G/037P	125	100	35	35	16	Frame 5
HD30-4T037G/045P	160	100	35	35	16	Frame 6
HD30-4T045G/055P	200	125	35	35	16	Frame 6
HD30-4T055G/075P	200	125	50	50	25	Frame 6
HD30-4T075G/090P	250	160	95	70	50	Frame 7
HD30-4T090G/110P	250	160	120	120	50	Frame 7
HD30-4T110G/132P	350	350	120	120	50	Frame 7
HD30-4T132G/160P HD30-4T132G/160P-C	400	400	185	185	95	Frame 8

Model	MCCB (A)	Contactur (A)	Supply Cable (mm ²)	Motor Cable (mm ²)	Ground Cable (mm ²)	Size
HD30-4T160G/200P HD30-4T160G/200P-C	500	400	240	240	120	Frame 8
HD30-4T200G/220P HD30-4T200G/220P-C	600	600	120*2 ⁽²⁾	120*2 ⁽²⁾	120	Frame 8
HD30-4T220G/250P HD30-4T220G/250P-C	600	600	120*2 ⁽²⁾	120*2 ⁽²⁾	120	Frame 9
HD30-4T250G/280P HD30-4T250G/280P-C	800	600	150*2 ⁽²⁾	150*2 ⁽²⁾	150	Frame 9
HD30-4T280G/315P HD30-4T280G/315P-C	800	800	185*2 ⁽²⁾	185*2 ⁽²⁾	185	Frame 9
HD30-4T315G/355P HD30-4T315G/355P-C	800	800	240*2 ⁽²⁾	240*2 ⁽²⁾	240	Frame 10
HD30-4T355G/400P HD30-4T355G/400P-C	800	800	240*2 ⁽²⁾	240*2 ⁽²⁾	240	Frame 10
HD30-4T400G/450P HD30-4T400G/450P-C	1000	1000	300*2 ⁽²⁾	300*2 ⁽²⁾	300	Frame 10
HD30-4T450G/500P HD30-4T450G/500P-C	1000	1000	300*2 ⁽²⁾	300*2 ⁽²⁾	300	Frame 10
HD30-4T500G	2000	1500	240*3 ⁽²⁾	240*3 ⁽²⁾	180*2 ⁽²⁾	Frame 11
HD30-4T560G	2000	1500	240*4 ⁽²⁾	240*4 ⁽²⁾	240*2 ⁽²⁾	Frame 11
HD30-4T630G	2200	1650	240*4 ⁽²⁾	240*4 ⁽²⁾	240*2 ⁽²⁾	Frame 11

Three phase: 500 - 690V, 50/60Hz

HD30-6T018G	100	63	6	6	6	Frame 12
HD30-6T022G	100	63	6	6	6	Frame 12
HD30-6T030G	125	100	10	10	10	Frame 12
HD30-6T037G	160	100	16	16	16	Frame 12
HD30-6T045G	200	125	16	16	16	Frame 12
HD30-6T055G	200	125	35	25	16	Frame 12
HD30-6T075G	250	160	35	35	16	Frame 13
HD30-6T090G	250	160	50	35	16	Frame 13
HD30-6T110G	350	350	50	50	25	Frame 13
HD30-6T132G	400	400	70	50	25	Frame 14
HD30-6T160G	500	400	95	70	35	Frame 14
HD30-6T200G	600	600	120	120	50	Frame 14
HD30-6T220G	600	600	120	120	50	Frame 15
HD30-6T250G	800	600	150	150	70	Frame 15
HD30-6T280G	800	800	185	185	70	Frame 15
HD30-6T315G	800	800	70*2	70*2	70	Frame 15
HD30-6T355G	800	800	95*2	95*2 ⁽²⁾	95	Frame 16
HD30-6T400G	1000	1000	120*2 ⁽²⁾	120*2 ⁽²⁾	120	Frame 16

(2): *2, *3, *4 means 2, 3, 4 power lines or motor lines paralleled.

Model	MCCB (A)	Contactora (A)	Supply Cable (mm ²)	Motor Cable (mm ²)	Ground Cable (mm ²)	Size
<p><i>Note: The parameters of each accessory in the table are ideal values. When the accessories are selected, they can be adjusted according to the actual situation on site, but try not to be smaller than the parameter values in the table.</i></p>						

4.2.2 Power terminal lug

Select the lug of power terminal according to the size of terminal, screw size and max. outer diameter of lug. Refer to Table 4-3.

Take the round terminal as an example.

Table 4-3 Selection of power terminal lug

Size	Screw size	Tightening torque (N. M)	Max. outer diameter of lug d (mm)
Frame 1	M3.5	0.8 - 1.2	7
Frame 2	M4	1.2 - 1.5	9.9
Frame 3 - Frame 4	M5	2.5 - 3.0	12
Frame 5 - Frame 5A	M6	4.0 - 5.0	15.5
Frame 6	M8	9.0 - 10.0	24
Frame 7	M10	17.6 - 22.5	30
Frame 8 - Frame 9	M12	31.4 - 39.2	35
Frame 10	M16	48.6 - 59.4	55
Frame 11	M16	48.6 - 59.4	42
Frame 12	M8	9.0 - 10.0	18
Frame 13	M8	9.0 - 10.0	23
Frame 14	M10	17.6 - 22.5	27
Frame 15	M12	31.4 - 39.2	30
Frame 16	M12	31.4 - 39.2	33

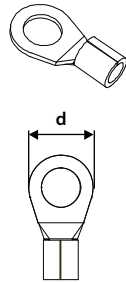

4.3 Main Circuit Terminals and Wiring



Danger

- The bare portions of the power cables must be bound with insulation tapes.



Warning

- Ensure that AC supply voltage is the same as rated input voltage of HD30.

4.3.1 Supply and Motor Terminal

Table 4-4 Supply and motor terminal description

<p>Frame 1 - Frame 2</p> <ul style="list-style-type: none"> • L1, L2, L3: Three-phase AC power input terminals • U, V, W: Output terminals, connect to three-phase AC motor • (+), (-): DC supply input terminals; DC input terminals of power regenerative unit • (+), BR: Braking resistor connection terminals • PE: Ground terminal, connect to the ground 	
<p>Frame 3 - Frame 6</p> <ul style="list-style-type: none"> • L1, L2, L3: Three-phase AC power input terminals • U, V, W: Output terminals, connect to three-phase AC motor • P1, (+): DC reactor connection terminals • (+), (-): DC supply input terminals; DC input terminals of power regenerative unit • (+), BR: Braking resistor connection terminals • PE: Ground terminal, connect to the ground 	

Frame 7 - Frame 9 (Contain -C)

- L1, L2, L3: Three-phase AC power input terminals
- U, V, W: Output terminals, connect to three-phase AC motor
- P1, (+): DC reactor connection terminals
- (+), (-): DC supply input terminals; DC input terminals of power regenerative unit
- PE: Ground terminal, connect to the ground

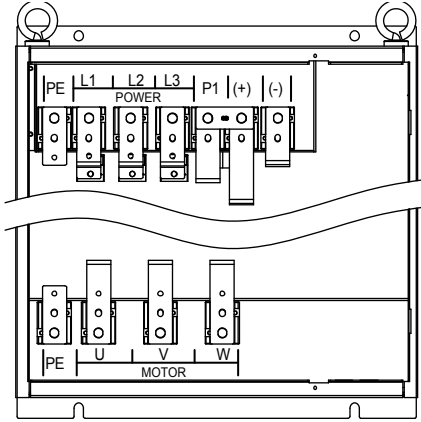

Frame 10 (Contain -C)

- L1, L2, L3: Three-phase AC power input terminals
- U, V, W: Output terminals, connect to three-phase AC motor
- (+), (-): DC supply input terminals; DC input terminals of power regenerative unit
- PE: Ground terminal, connect to the ground

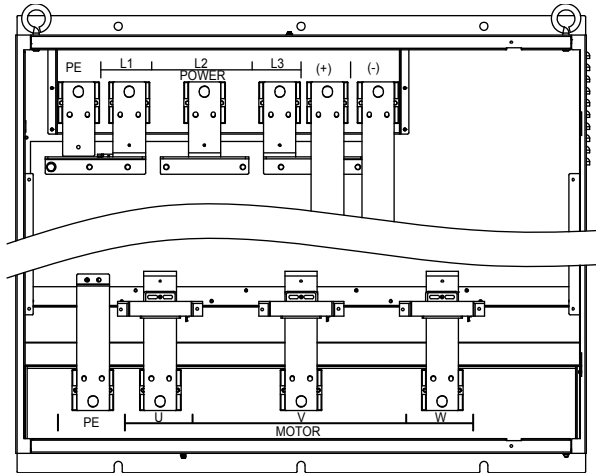

Frame 11

- L1, L2, L3: Three-phase AC power input terminals
- U, V, W: Output terminals, connect to three-phase AC motor
- (+), (-): DC supply input terminals; DC input terminals of power regenerative unit
- PE: Ground terminal, connect to the ground

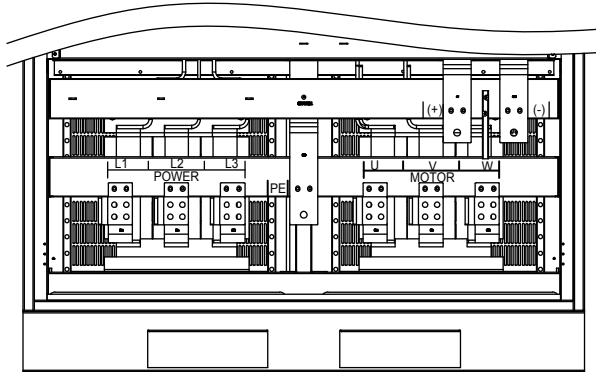

Frame 12 - Frame 13

- L1, L2, L3: Three-phase AC power input terminals
- U, V, W: Output terminals, connect to three-phase AC motor
- P1, (+): DC reactor connection terminals
- (+), (-): DC supply input terminals; DC input terminals of power regenerative unit
- PE: Ground terminal, connect to the ground

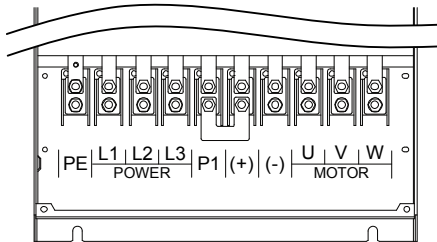

Frame 14

- L1, L2, L3: Three-phase AC power input terminals
- U, V, W: Output terminals, connect to three-phase AC motor
- P1, (+): DC reactor connection terminals
- (+), (-): DC supply input terminals; DC input terminals of power regenerative unit
- PE: Ground terminal, connect to the ground

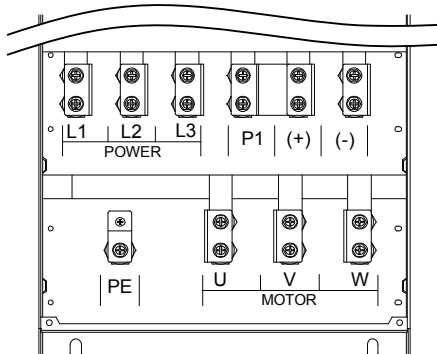

Frame 15 - Frame 16

- L1, L2, L3: Three-phase AC power input terminals
- U, V, W: Output terminals, connect to three-phase AC motor
- P1, (+): DC reactor connection terminals
- (+), (-): DC supply input terminals; DC input terminals of power regenerative unit
- PE: Ground terminal, connect to the ground

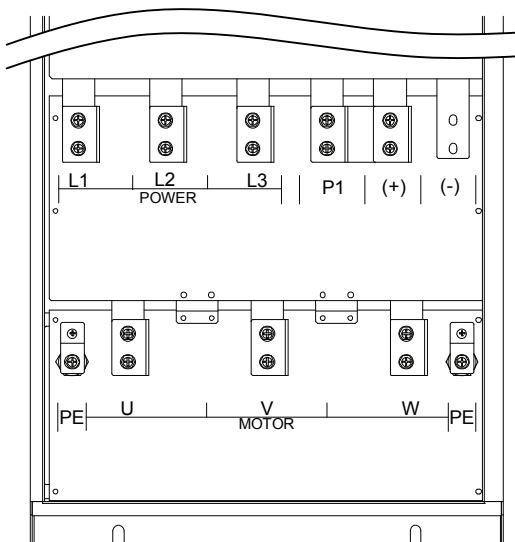

4.3.2 Power Terminal Wiring

During trial operation, make sure the inverter runs forward when the forward command is enabled. If not, switch any two of the output terminals (U, V, W) or modify the setting of parameter F00.17 to change the motor's direction.

The supply and motor connection are shown as Table 4-5.

For selection of contactor, MCCB, power cable, motor cable and ground cable, refer to section 4.2 Peripheral Accessories Selection (on page 21).

Refer to section 8.5 Braking Unit and Braking Resistor (on page 129) for braking resistor and unit.

Refer to section 8.6 Reactor Selection (on page 132) for AC reactors and DC reactors.

Table 4-5 Supply and motor connection

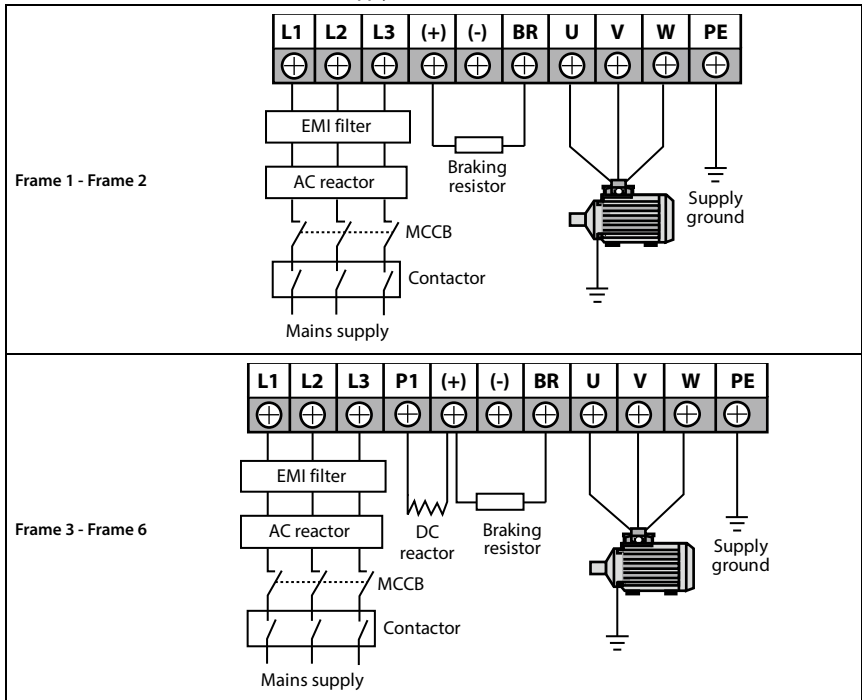

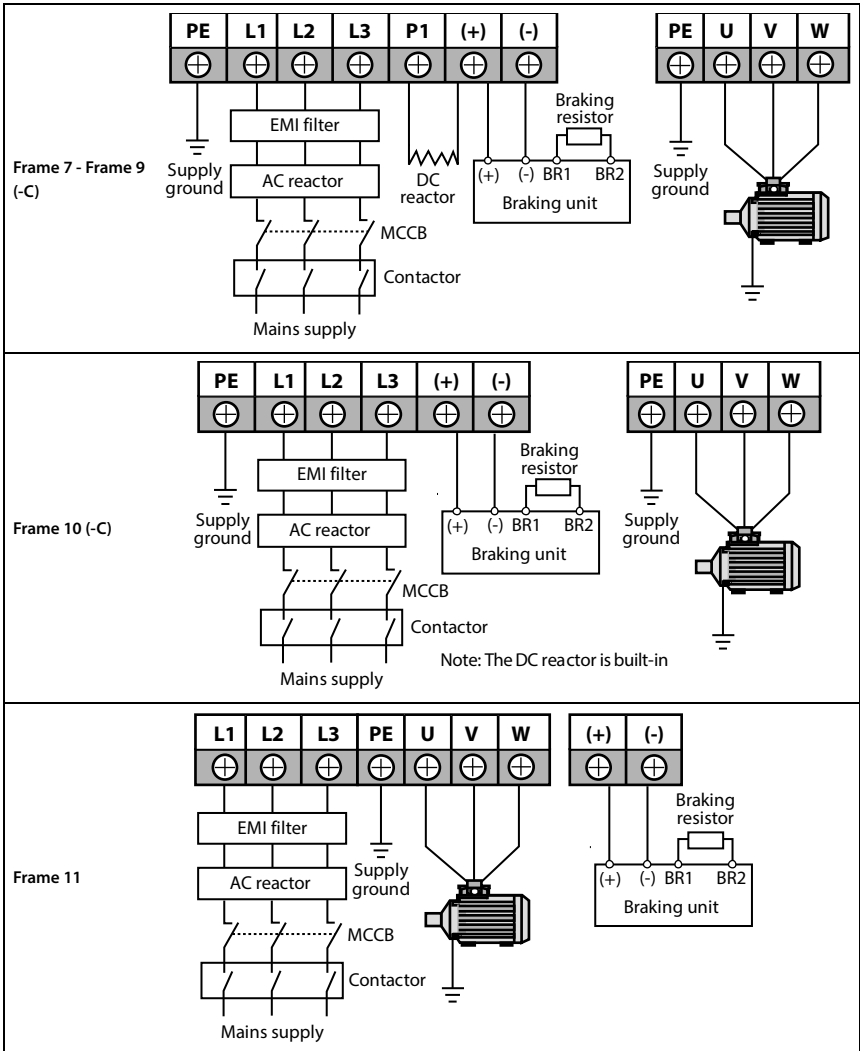

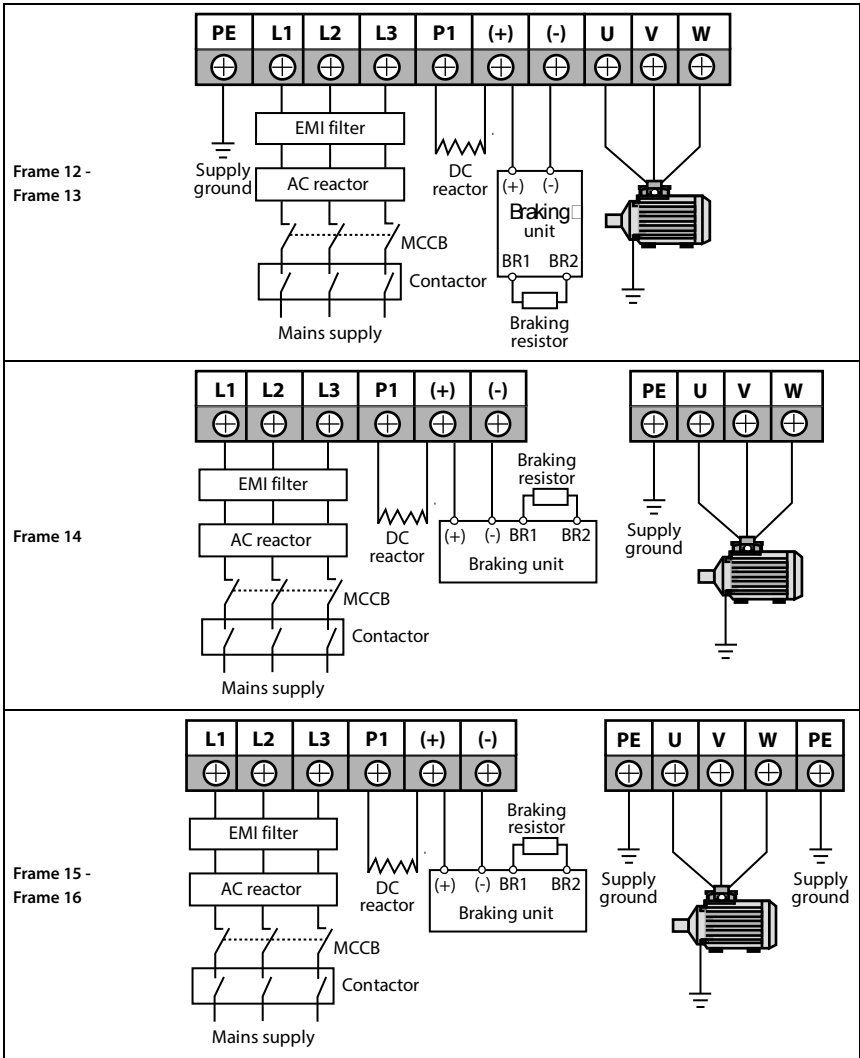

4.4 Control Board



Danger

- The control circuit is basically isolated with the power circuit. Do not touch HD30 after it is powered.





Warning

- If the control circuit is connected to external devices with live touchable port, it should increase an additional isolating barrier to ensure that voltage classification of external devices not be changed.
- If connect the communication terminal of the control circuit to the PC, choose the RS485/232 isolating converter which meets the safety requirement.
- Only connect the relay terminal to AC 220V voltage signal. Other control terminals are strictly forbidden for this connection.

4.4.1 Communication Terminal

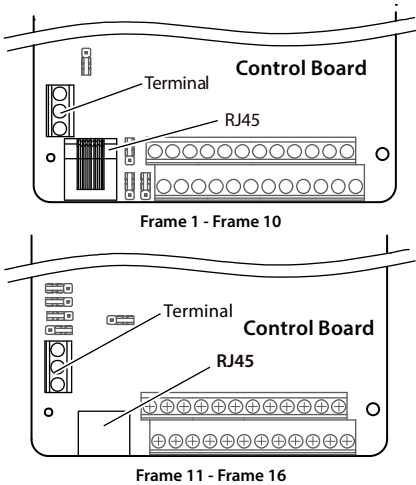
Do not use communication terminal and RJ45 simultaneously.

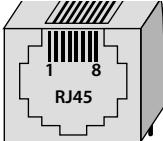
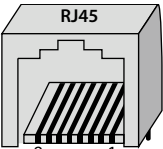

	Terminal	Description
	A	485+
	B	485-
	Pin	Difinition
	1,3	+5V
	2	485+
	4,5,6	GND
	7	485-
	8	Unused
Frame 1 - Frame 10		
	Pin	Difinition
	1,3	+5V
	2	485+
	4,5,6	GND
	7	485-
	8	Unused
Frame 1 - Frame 10		

4.4.2 Jumper

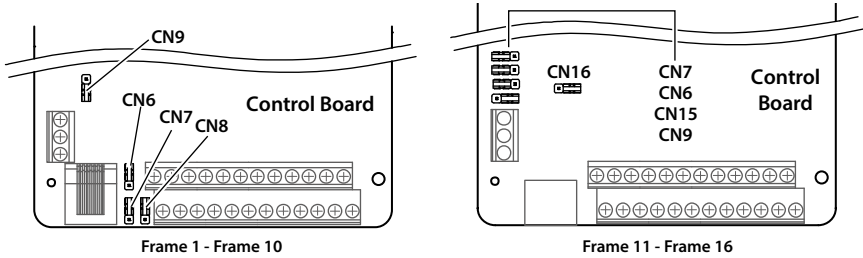

Figure 4-1 Jumper position

Table 4-6 Jumper description (Frame 1 - Frame 10)

Jumper	Description
	AI2 can select voltage or current signal. <ul style="list-style-type: none"> Pin 1 & 2 are short-connected, AI2 inputs voltage signal (factory setting). Pin 2 & 3 are short-connected, AI2 inputs current signal.
	AO1 can select voltage or current signal. <ul style="list-style-type: none"> Pin 1 & 2 are short-connected, AO1 outputs voltage signal (factory setting). Pin 2 & 3 are short-connected, AO1 outputs current signal.
	AO2 can select voltage or current signal. <ul style="list-style-type: none"> Pin 1 & 2 are short-connected, AO2 outputs voltage signal (factory setting). Pin 2 & 3 are short-connected, AO2 outputs current signal.
	SCI communication can select proper resistance. <ul style="list-style-type: none"> Pin 1 & 2 are short-connected, select the proper resistance. Pin 2 & 3 are short-connected, no resistance (factory setting).

4

Table 4-7 Jumper description (Frame 11 - Frame 16)

Jumper	Description
	AI2 can select voltage or current signal. <ul style="list-style-type: none"> Pin 1 & 2 are short-connected, AI2 inputs voltage signal (factory setting). Pin 2 & 3 are short-connected, AI2 inputs current signal.
	AO1 can select voltage or current signal. <ul style="list-style-type: none"> Pin 1 & 2 are short-connected, AO1 outputs voltage signal (factory setting). Pin 2 & 3 are short-connected, AO1 outputs current signal.
	SCI communication can select proper resistance. <ul style="list-style-type: none"> Pin 1 & 2 are short-connected, select the proper resistance. Pin 2 & 3 are short-connected, no resistance (factory setting).
	Impedance selection for AI2 analog current input: <ul style="list-style-type: none"> Pin 1 & 2 are short connected, the input impedance is 500Ω (factory setting). Pin 2 & 3 are short connected, the input impedance is 250Ω.
	AO2 can select voltage or current signal. <ul style="list-style-type: none"> Pin 1 & 2 are short-connected, AO2 outputs voltage signal (factory setting). Pin 2 & 3 are short-connected, AO2 outputs current signal.

4.4.3 Control Board Terminal

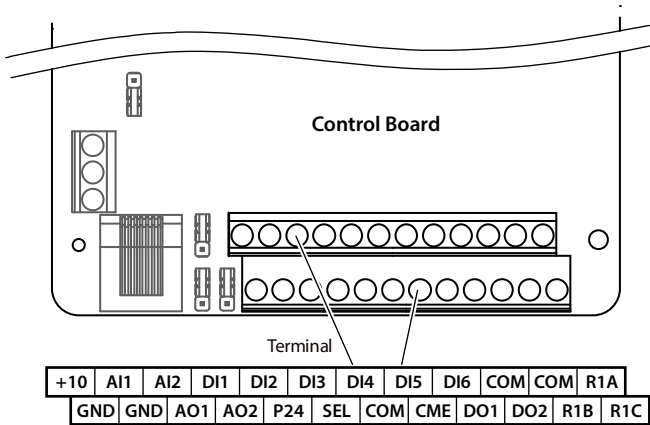

Figure 4-2 Control board terminal

Table 4-8 Control board terminal description

Terminal		Description
+10, GND	+10V power supply	Analogue input use +10V power supply, max. output current is 100mA GND is isolated to COM
AI1, AI2	Analogue input	AI1 input voltage: 0 - 10V (input impedance: 34kΩ) AI2 input voltage: -10V - 10V (input impedance: 34kΩ) AI2 input current: 0 - 20mA (input impedance: 500Ω) • AI2, AI3 can select voltage/current
AO1, AO2	Analogue output	Output voltage/current signal: 0 - 10V/0 - 20mA
GND	Analogue ground	Programmable output
DI1 - DI6	Digital input	Programmable bipolar optional input signal Input voltage: 0 - 30VDC DI1 - DI5 input impedance: 4.7kΩ, DI6 input impedance: 1.6kΩ • DI6 can be selectable for high-frequency input, max-frequency 50kHz
P24, COM	Digital power supply	Digital input use +24V as supply, max. output current is 200mA COM is isolated to CME
SEL	Digital input common terminal	SEL and P24 are connected by default (factory setting) • Disconnect SEL and P24 when use external power to drive DI
DO1, CME	Digital output	Programmable optocoupler isolation • DO1, DO2 open collector output, output voltage: 0 - 30VDC, max. output current 50mA
DO2, COM	Digital output	• DO2 can be selectable for high-frequency output, max-frequency 50kHz CME is isolated to COM, shortly connected to COM by default • Disconnect CME and COM when they are isolating output
R1A/R1B/R1C	Relay output	Programmable output, contact rating: 250VAC/3A or 30VDC/1A • R1B,R1C: normally closed; R1A,R1C: normally open

Note:

Limit the current within 3A if the relay terminal is to connect to AC 220V voltage signal.

4.4.4 Control Terminal Wiring

To reduce the interference and attenuation of control signal, length of control cable should limit within 50m. There should be more than 0.3m between the control cable and the motor cable.

The control cable must be shielded cable. The analogue signal cable must be shielded twisted pair.

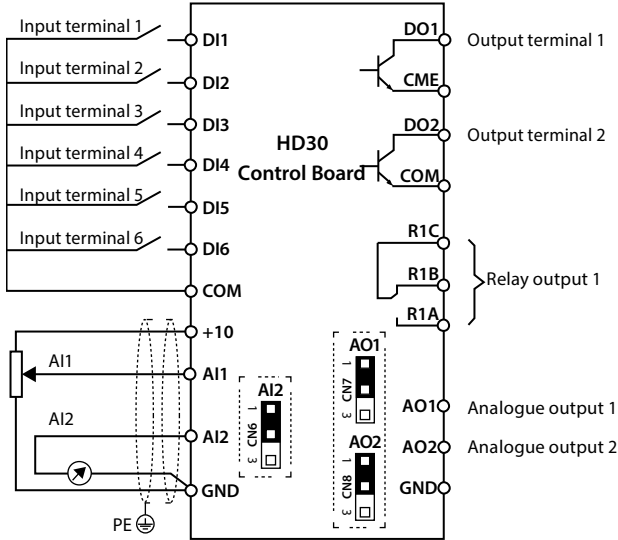

Figure 4-3 HD30 control board connection

Digital Input Connection

Dry contact

Using the internal 24V power supply (SEL and P24 are short-connected at factory) or external power supply (remove the connector between SEL and P24), their connections are shown in Figure 4-4.

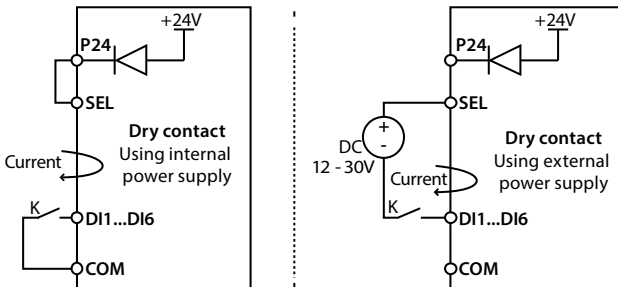

Figure 4-4 Dry contact connection

Source / Drain

Using external power supply, the source / drain connection are shown in Figure 4-5. (Remove the connector between SEL and P24)

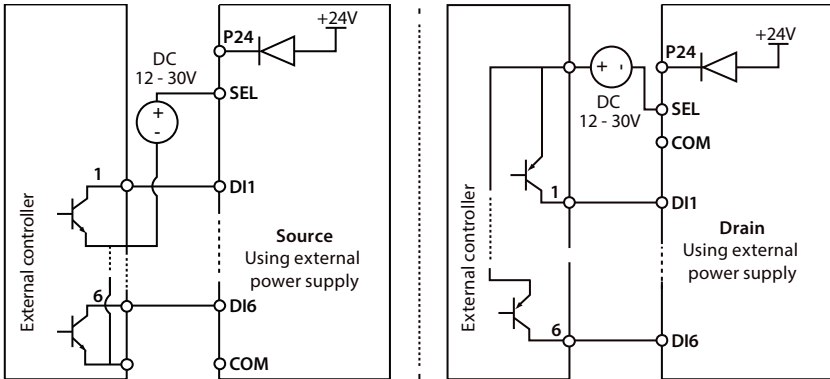

Figure 4-5 Source / Drain connection when using external power

Using internal 24V power supply, it is NPN / PNP connection in which external controller is common emitter output, as shown in Figure 4-6. (For PNP, remove the connector between SEL and P24)

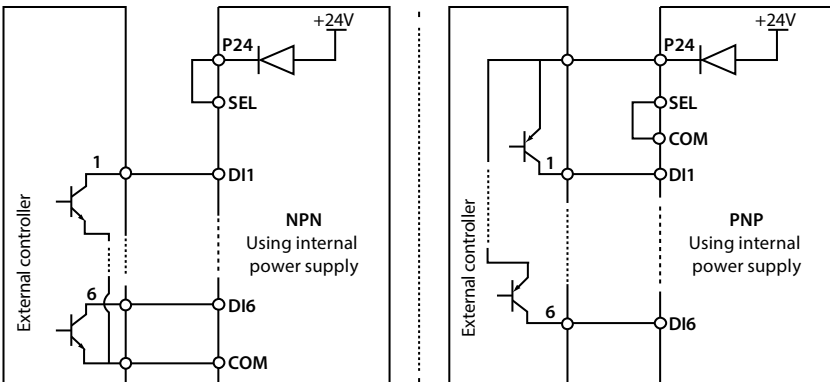

Figure 4-6 NPN (source) / PNP (drain) connection when using internal power supply

Analogue Input (AI) Connection

The AI1 is voltage input and the range is 0 - 10V, as shown in Figure 4-7.

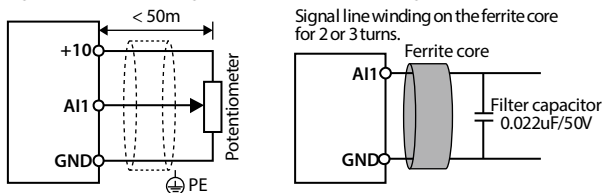

Figure 4-7 AI1 connection

Note:

1. To reduce the interference and attenuation of control signal, length of control cable should limit within 50 m, and the shield should be reliably grounded.
2. In serious interference occasions, the analogue input signal should add filter capacitor and ferrite core, as shown in Figure 4-7.

AI2 are selected as voltage input and the range is -10 - +10V. When selecting internal +10V of HD30, refer to Figure 4-7; selecting +/-10V external supply, refer to Figure 4-8.

AI2 are selected as current input and the range is 0 - 20mA, refer to Figure 4-8.

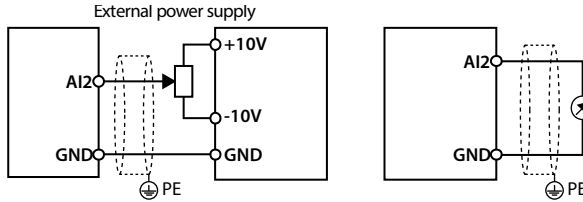

Figure 4-8 AI2 connection

Digital Output (DO) Connection

DO1 is open collective output. DO1 can use internal 24V power supply of inverter or external power supply. The connection is shown in Figure 4-9.

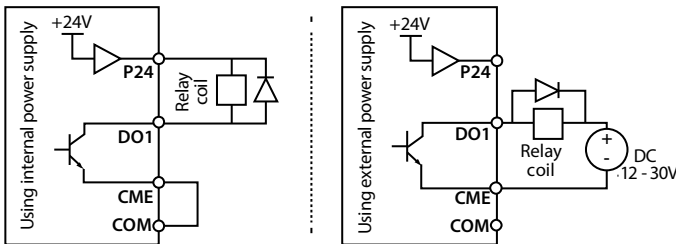

Figure 4-9 DO1 connection

DO2 is open collective output, refer to Figure 4-9.

DO2 is pulse frequency output; DO2 can use internal 24V power supply of inverter or external power supply. The connection is shown in Figure 4-10.

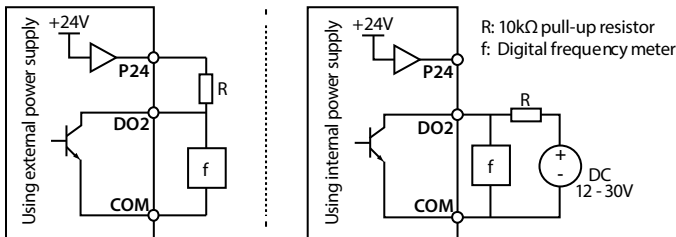

Figure 4-10 DO2 connection

4.5 Meet EMC Requirement of Installation

4.5.1 Correct EMC Installation

According national standards GB/T12668.3, the inverter should meet the two requirements of electromagnetic interference (EMI) and anti-electromagnetic interference. The international standards IEC/61800-3 (VVVF drive system part 3: EMC specifications and test methods) are identical to the national standards GB/T12668.3.

HD30 are designed and produced according to the requirements of IEC/61800-3. Please install the inverter as per the description below so as to achieve good electromagnetic compatibility (EMC).

Divide the installation space into different areas:

- In a drive system, the inverter, control equipment and sensors are installed in the same cabinet, the electromagnetic noise should be suppressed at the main connecting points with the EMI filter and input reactor installed in cabinet to satisfy the EMC requirements.
- The most effective but expensive measure to reduce the interference is to isolate the noise source and the noise receiver, which should be considered in mechanical system design phase. In driving system, the noise source can be inverter, braking unit and contactor. Noise receiver can be automation equipment, encoder and sensor etc.

The mechanical/system is divided into different EMC areas according to its electrical characteristics. The recommended installation positions are shown in Figure 4-11.

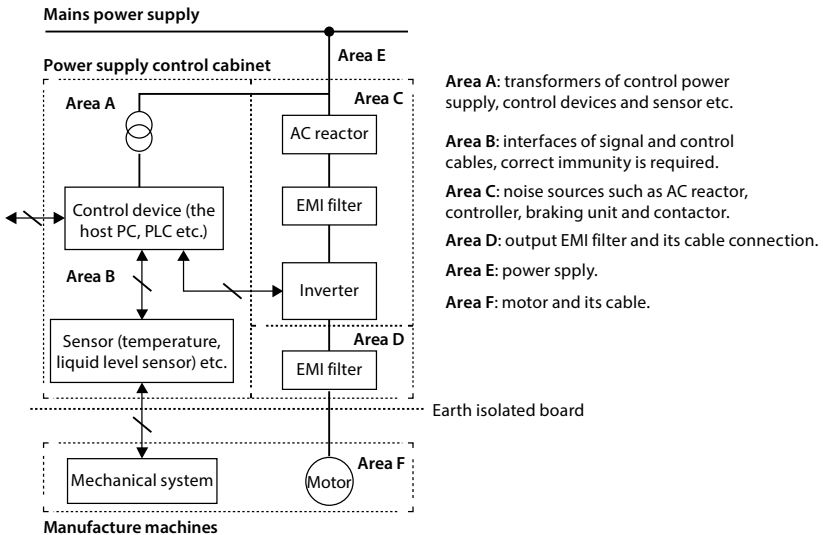

Figure 4-11 System wiring

- All areas should be isolated in space to achieve electromagnetic decoupling effect.
- The min. distance between areas should be 20cm, and use grounding bars for decoupling among areas, the cables from different area should be placed in different tubes.
- EMI filters should be installed at the interfaces between different areas if necessary.
- Bus cable (such as RS485) and signal cable must be shielded.

4.5.2 Wiring Requirement

In order to avoid interference intercoupling, it is recommended to separate the power supply cables, motor cables and the control cables, and keep enough distance among them, especially when the cables are laid in parallel and are long enough.

The signal cables should cross the power supply cables or motor cables, keep it perpendicular (90°) as shown in Figure 4-12.

Distribute the power supply cables, motor cables and control cables in different pipelines.

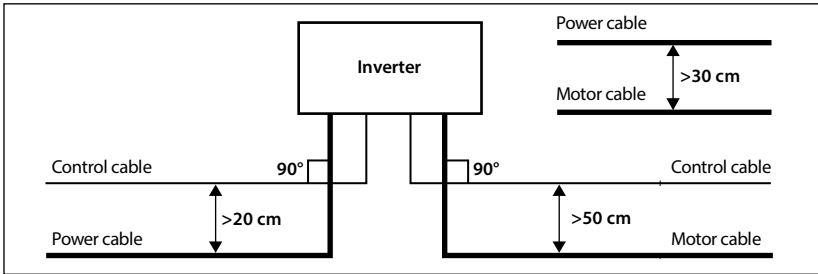

Figure 4-12 System wiring

Shielded / Armoured cable: High frequency low impedance shielded cable should be used. For example: copper net, aluminum net or iron net.

Normally, the control cables must use the shielded cables and the shielding metal net must be connected to the metal enclosure of the inverter by cable clamps as shown in Figure 4-13.

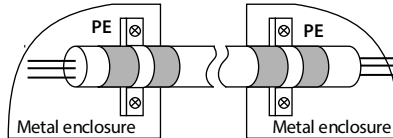

Figure 4-13 Shielded cable connection

4.5.3 Motor Connection

The longer cable between the controller and the motor is, the higher frequency leakage current will be, causing the inverter output current to increase as well. This may affect peripheral devices.

When the cable length is longer than 100 meters, it is recommended to install AC output reactor and adjust the carrier frequency according to Table 4-9.

Table 4-9 Carrier frequency and the cable length between inverter and motor

Cable length	< 30m	30 - 50m	50 - 100m	≥ 100m
Carrier frequency	15kHz below	10kHz below	5kHz below	2kHz below

The cross sectional area (CSA) of controller cables should refer to [Table 4-2, on page 22](#).

The controller should be derated if motor cables are too long or their CSA is too large. The current should be decreased by 5% when per level of CSA is increased. If the CSA increase, so do the current to ground and capacitance.

4.5.4 Ground Connection

The grounding terminals PE must be connected to ground properly. The grounding cable should be as short as possible (the grounding point should be as close to the controller as possible) and the grounding area should be as large as possible. The grounding resistance should be less than 10Ω.

Do not share the grounding wire with other devices (A). HD30 can share grounding pole with other devices (C). It achieves the best effect if HD30 and other devices use dedicated grounding poles (B), as shown in Figure 4-14.

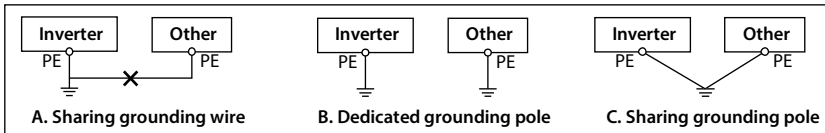

Figure 4-14 Grounding method

When using more than one controller, be careful not to loop the ground wire as shown in Figure 4-15.

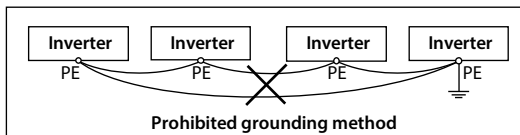

Figure 4-15 Prohibited grounding method

4.5.5 EMI Filter

The EMI filter should be used in the equipment that may generate strong EMI or the equipment that is sensitive to the external EMI. The EMI filter is a dual-way low pass filter through which lower frequency current can flow while higher frequency current can hardly flow.

Function of EMI filter

1. The EMI filter ensures the equipment not only can satisfy the conducting emission and conducting sensitivity in EMC standard but also can suppress the radiation of the equipment.
2. It can prevent the EMI generated by equipment from entering the power cable and the EMI generated by power cable from entering equipment.

Common mistakes in using EMI filter

1. Too long the power cable is between the EMI filter and the inverter

The filter inside the cabinet should be located near to the input power source. The length of the power cables should be as short as possible.

2. Too close the input and output cables of the EMI filter

The distance between input and output cables of the filter should be as far apart as possible. Otherwise the high-frequency noise may be coupled between the cables and bypass the filter. Thus, the filter will become ineffective.

3. Bad grounding of the EMI filter

The enclosure of EMI filter must be grounded properly to the metal case of the controller. In order to achieve better grounding effect, make use of a special grounding terminal on the enclosure. If using one cable to connect the filter to the case, the grounding is useless for high frequency interference.

When the frequency is high, so is the impedance of cable, hence there is little bypass effect.

The correct installation: The filter should be mounted on the enclosure of equipment. Ensure to clear away the insulation paint between the filter case and the enclosure for good grounding contact.

4.5.6 Countermeasures for Conduction, Radiation and Radio Frequency Interference

EMI of the inverter

The operating theory of inverter means that some EMI is unavoidable. The inverter is usually installed in a metal cabinet which normally little affects the instruments outside the metal cabinet. The cables are the main EMI source. If connect the cables according to this manual, the EMI can be suppressed effectively.

If the inverter and other control equipment are installed in one cabinet, the area rule must be observed. Pay attention to the isolation between different areas, cable layout and shielding.

Reducing conducted interference

Add a noise filter to suppress conducted interference on the output side. Additionally, conducted interference can be efficiently reduced by threading all the output cables through a grounded metal tube. And conducted interference can be dramatically decreased when the distance between the output cables and the signal cables is above 0.3m.

Reducing RF interference

The I/O cables and the inverter produce radio frequency interference. A noise filter can be installed both on the input side and output side, and shield them with iron utensil to reduce RF interference. The wiring distance between the inverter and the motor should be as short as possible shown in Figure 4-16.

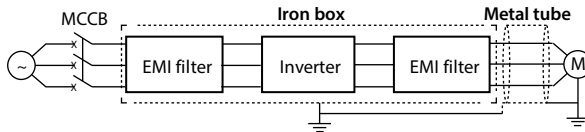

Figure 4-16 RF interference clearing

4.5.7 Reactor

AC input reactor

The purpose of installing an AC input reactor: to increase the input power factor; to dramatically reduce the harmonics on the input side at the high voltage point of common coupling and prevent input current unbalance which can be caused by the phase-to-phase unbalance of the power supply.

DC reactor

The installation of a DC reactor can increase the input power factor, improve the overall efficiency and thermal stability of controller, substantially eliminate the upper harmonics influence on performance of inverter, and decrease the conducted and radiated electromagnetic emissions from the inverter.

AC output reactor

When the length of cable between inverter and motor is more than 100m, it will cause leakage current and controller tripping. It is suggested that user should consider installing an AC output reactor.

Chapter 5 Operation Instructions



- Only when the terminal cover of HD30 has been fitted can you switch on AC power source. Do not remove the cover after power is switched on.
- Ensure the motor and the mechanical device are in the use application before HD30 starts.
- To change the MCB, correctly set the parameters before operating.



- Do not check or detect the signal during HD30 running.
- Do not randomly change HD30 parameter setting.
- Please thoroughly complete all control debugging and testing, make all adjustments and conduct a full safety assessment before switching the run command source of HD30.
- Do not touch the energy-depletion braking resistor due to the high temperature.

5.1 Function Description

5

Note:

In the following sections, you may encounter control, running and status of HD30 description many times. Please read this section. It will help you to correctly understand and use the functions to be discussed.

5.1.1 Operation Mode

The physical channel: HD30 receives the run command (start, run, stop, jog, etc.), which can be selected via F00.11 and DI terminals:

Operation Mode	Description
keypad	With RUN, STOP, JOG on the operation panel to start the inverter, stop, jog run control.
control terminals	Use the control terminal to start the inverter and stop the operation control.
SCI communication	Through the SCI communication drive start, stop running control.

5.1.2 Inverter Frequency Setting Source

The final setting frequency of the HD30 is calculated (F19.01) by the main setting channel (F00.10) and the auxiliary setting channel (F19.00).

When the auxiliary setting channel is the same as the main setting channel (except analog), the frequency is set by the main set channel.

Master setting frequency (F00.10)	Auxiliary setting frequency (F19.00)	Remark
/	0: No auxiliary frequency channel	
0: Keypad setting, F00.13 set the initial value	1: Keypad setting, F19.13 set the initial value	Keypad ▲, ▼ adjust
1: Terminal setting, F00.13 set initial	2: Terminal setting, F19.03 set initial	Terminal UP/DN adjust

Master setting frequency (F00.10)	Auxiliary setting frequency (F19.00)	Remark
2: SCI communicaiton set, initial value is 0	3: SCI communicaiton set, initial value 0	
3: Analogue setting	4: Analogue setting	
4: Terminal pulse setting	5: Terminal pulse setting	DI6 terminals F15.05 set 53
/	6: PID output setting	
6 - 9: AI1 - AI4 setting	7 - 10: AI1 - AI4 setting	
10: Keypad potentiometer setting	11: Keypad potentiometer setting	

5.1.3 Inverter Status

Inverter Status	Description
Stop status	After the inverter is powered on, the inverter U / V / W terminal has no output and the operation status indicator of the operation panel flashes if no operation command is input or the stop command is executed during operation.
Run status	After the inverter receives the run command, the inverter U / V / W terminal starts to output, and the operation status indicator of the operation panel is on.
Motor parameters auto-tuning	Set F08.06 / F13.17 = 1 or 2, HD30 will receive the run command then enter motor parameters auto-tuning status. If the auto-tuning process is completed, the inverter will enter into stop status.
System running state	Refers to the inverter U / V / W terminal has output or zero frequency block output or sleep wait and then restart the state. In this state, the operation status indicator of the operation panel is on, the LED flashes to display the stop status parameter, and the parameters that can not be modified in the inverter can not be modified.

5.1.4 Inverter Running Mode

Running Mode	Description
Jog	In the keypad control mode, when JOG key is pressed, the inverter will run at the jog frequency (F00.15, F03.15 and F03.16 are required to set). In the terminal control mode, the DI terminal jog command (function 20 - 25) is received and run according to the corresponding jog frequency (F00.15, F03.15, F03.16 and F05.21 are required set).
Process PID adjustment	The process PID adjustment operation function is valid (F04.00 = 1). The inverter will select the process PID adjustment operation mode, that is, PID adjustment according to the setting and feedback amount (set F04 Group). <ul style="list-style-type: none"> The process PID adjustment operation mode can be disabled by the DI terminal (function No. 33) to switch to other operation mode.
MS SPEED	The multi - stage frequency 1 - 15 (F06.00 - F06.14) is selected for multi - step speed operation via the logical combination of DI terminal (function 13 - 16).
Simple PLC	The simple PLC function selection is valid (F06.15 = 1). The inverter will run in simple PLC mode. The inverter will run according to the preset operating parameters (see F06 Group parameter). <ul style="list-style-type: none"> The simple PLC operation mode can be paused by the DI terminal (function No. 30).
Wobble operation	F07.00 = 1, the inverter will run in accordance with the pre-set operating parameters (see F07 Group parameter).

5.2 Operating Instructions

5.2.1 Keypad

The standard HD30 are installed with LED keypad which is shown in Table 5-1.

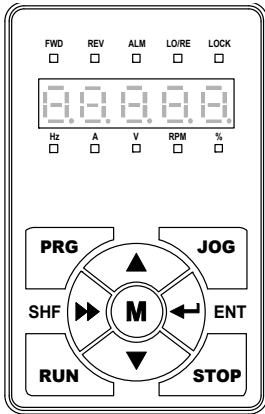

Table 5-1 Key description of keypad

Key	Description
PRG	Entry or exit programming key
JOG	In the keypad control, press the key to jog run HD30
RUN	In the keypad control, press this key to run HD30
STOP	a. In the keypad control, press this key to stop HD30 b. In the detection fault, press this key to reset at fault
M	Set certain function by F00.12
▲	Increase value or parameter
▼	Decrease value or parameter
▶	a. Select display parameter and shift bit b. Stop in loop / Display the parameter during running
↶	a. Enter lower menu b. Confirm saving the data

The keypad consists of 5 status indicators and 5 unit indicators and shown as Table 5-2.

Table 5-2 Indicator description of the keypad

Mark	Name	■: Lighting	□: Flashing	□: Lightless
FWD	Forward status	HD30 is forward running at the moment	The start of HD30 is forward running next time	
REV	Reverse status	HD30 is reverse running at the moment	The start of HD30 is reverse running next time	
ALM	Alarm status	HD30 is faulty at the moment		HD30 is well at the moment
LO/RE	Remote / Local status	HD30 is in terminal control mode	HD30 is in communication control mode	HD30 is in keypad control mode
LOCK	Password locked status	The user password lock of HD30 is avail		There is no user password or unlocked
Hz	Frequency unit	The unit of the present parameter is Hz	The present parameter is output frequency	
A	Current unit	The unit of the present parameter is A		
V	Voltage unit	The unit of the current parameter is V		
RPM	Rotary speed unit	The unit of the present parameter is rpm	The present parameter is rotary speed unit	
%	% unit	The unit of the present function parameter is %		

The keypad of HD30 has five LED displays and their meanings are shown in Table 5-3.

Table 5-3 LED display description

LED display	Meaning	LED display	Meaning	LED display	Meaning	LED display	Meaning
0	0	A	A	J	J	U	U
1	1	b	b	L	L	u	u
2	2	C	C	n	n	y	y
3	3	c	c	o	o	-	-
4	4	d	d	P	P	.	Point
5	5	E	E	q	q	Full display	Full display
6	6	F	F	r	r	No display	No display
7	7	H	H	S	S	Flash modifiable	Flash modifiable
8	8	h	h	T	T		
9	9	i	i	t	t		

5.2.2 Display Status

Parameter display status at stop/run

When HD30 is in stop/run status, the keypad will display stop or run status and its parameters, as shown in Figure 5-1.

Other parameters (F18.08 - F18.13) or F18.02 - F18.07 can be displayed by pressing **▶▶**.

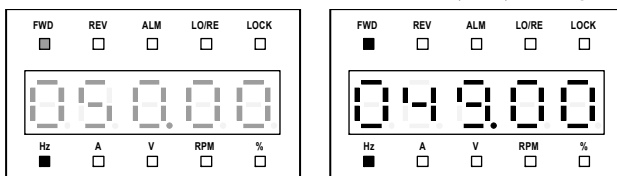

Figure 5-1 Display status of stop (left) and run (right)

Function parameter editing status

At stop, run or fault alarm status, press **PRG** to enter function parameter editing status (see the description of parameter F01.00 and the user password unlock and modify of section 5.2.3), as shown in Figure 5-2.

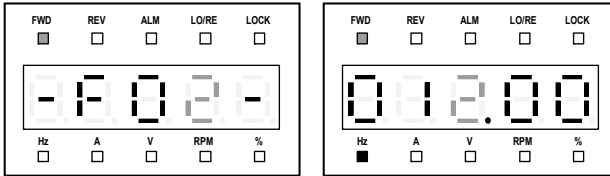

Figure 5-2 Parameter editing status

Fault alarm status

If the inverter detects a fault signal, the keypad will enter the fault alarm status and flashing display the fault code, as shown in Figure 5-3.

You can enter F20.21 - F20.37 to check the fault history.

The inverter can be reset by pressing **STOP** key, or by sending the reset commands via the control terminal or communication reset port.

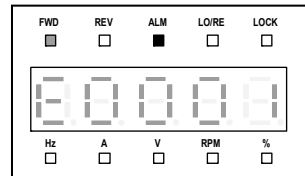

Figure 5-3 Fault alarm status

Special display status

The special display status includes the setting and unlocked password status, upload and download parameter, power on initialization, parameter auto-tuning, keypad self-check and restored factory settings, as shown in Figure 5-4.

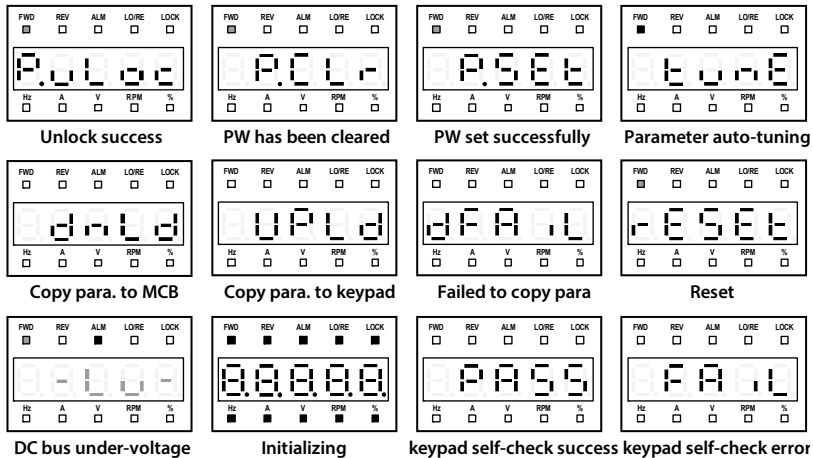

Figure 5-4 Special display status

5.2.3 Keypad Operation Examples

Four-level menu switching operation

The keypad uses four-level menu configuration for parameter setting or other operations.

Configuring mode can be displayed in 4-level menu: **mode setting (first-level)**→**function parameter Group setting (second-level)**→**function parameter setting (third-level)**→**parameter setting (fourth-level)**. The operation process is shown in Figure 5-5 and the description of the keys is shown in Table 5-4.

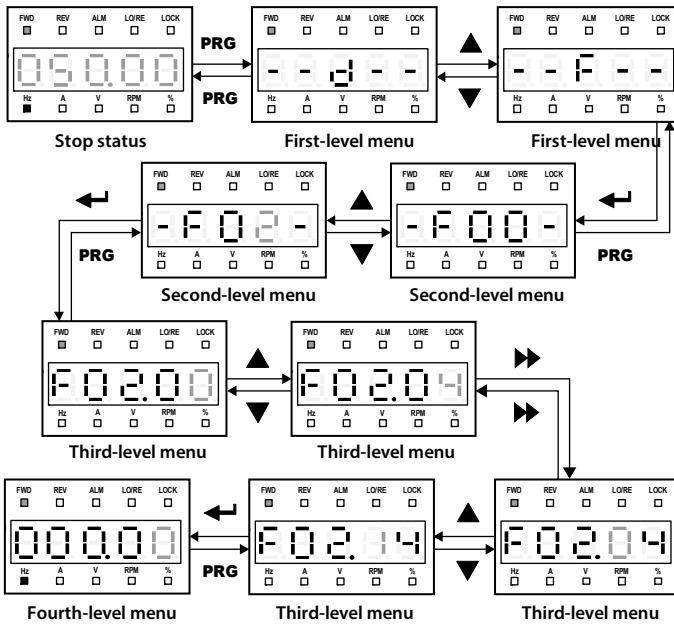

Figure 5-5 Four-level operation process

Table 5-4 Switching four-level description of the key

Key	First-level menu	Second-level menu	Third-level menu	Fourth-level menu
PRG	Fault, return to fault display; Fault cleared, return to run or stop status display	Return to first-level menu	Return to second-level menu	Do not save the present value and return to third-level
←	Enter to second-level menu	Enter to third-level menu	Enter to fourth-level menu	Save the present value and return to third-level
▲	Select function Group. Cycle according to d-F-U-y	Modify No. function. Increase by 1 when press this key one time	Modify the internal No. of function Group. Increase by 1 according to the present modified bit	Modify function value. Increase by 1 according to the present modified bit

Key	First-level menu	Second-level menu	Third-level menu	Fourth-level menu
▼	Select function Group. Cycle according to y-U-F-d	Modify No. function. Decrease by 1 when press this key one time	Modify the internal No. of function Group. Decrease by 1 according to the present modified bit	Modify function value. Decrease by 1 according to the present modified bit
▶▶	Invalid	Invalid	Switch units and tens	Switch units, ten thousands, thousands, hundreds, tens

Parameter setting

For example: To modify the setting value of the F02.14 from 000.00Hz to 012.00Hz, refer to Figure 5-6.

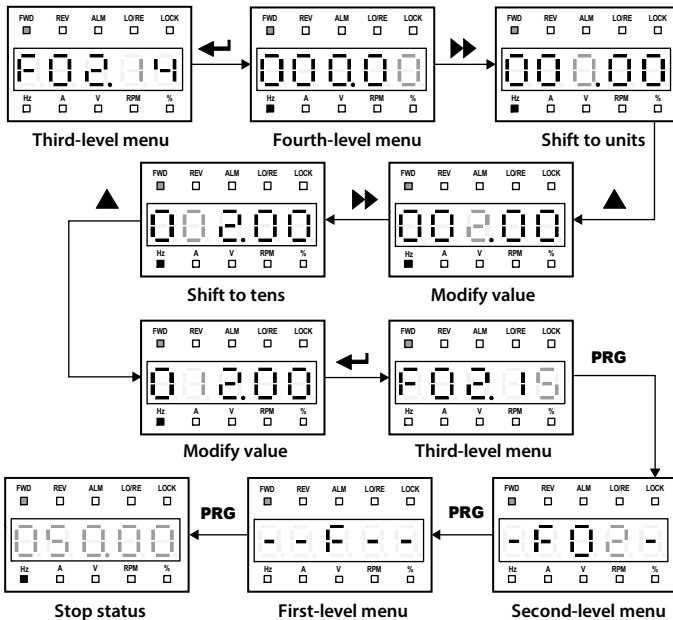

Figure 5-6 Parameter setting

When setting fourth-level menu, if the parameter is not in anti-color displaying, it indicates that this parameter can't be modified. The possible reasons are as follows:

- The function parameter can't be modified, such as the actual detected parameters or recorded parameters etc.
- Only when the controller stops can the function parameter be modified.
- Only input the correct password can it edit the function parameter due to the valid password.

Switching display parameters at stop status

The keypad can display six stop parameters (F18.08 - F18.13) in loop. Take the default parameter as an example, Figure 5-7 shows the switching process at stop status.

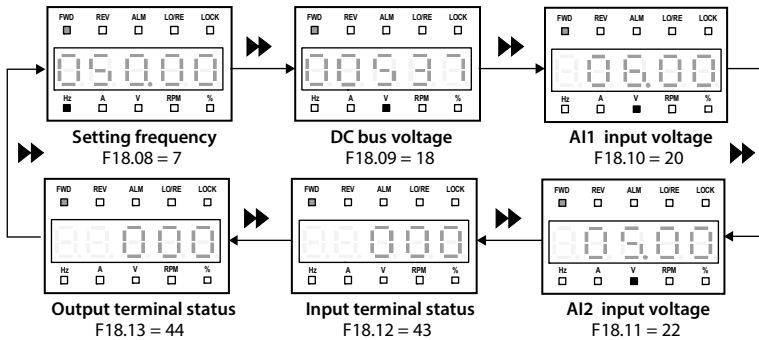

Figure 5-7 Switching display parameters at stop status

Unlock user's password

F01.00 = non-zero, press **PRG** key to exit to stop / run display status, or detect no press on the keypad for 5 minutes, the user's password will be valid. The **LOCK** indicator of keypad will be lighting.

The operation of unlock user's password is as shown in Figure 5-8 which takes 4 as the user's password.

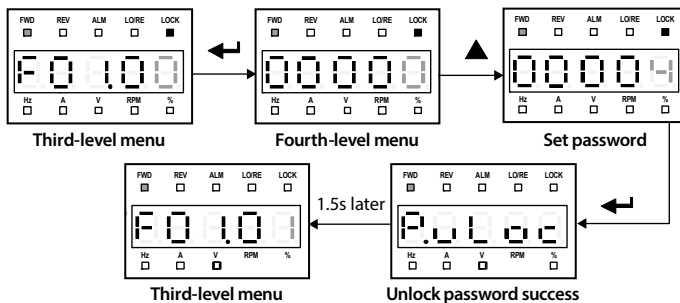

Figure 5-8 Operation of unlocking user's password

Modify user's password

If no password, directly modify the value of F01.00 according to Figure 5-9.

If there is password, unlock the password according to Figure 5-8. When the lock successfully displays "F01.01", you can set a new password according to Figure 5-9 which takes "02004" as the new password.

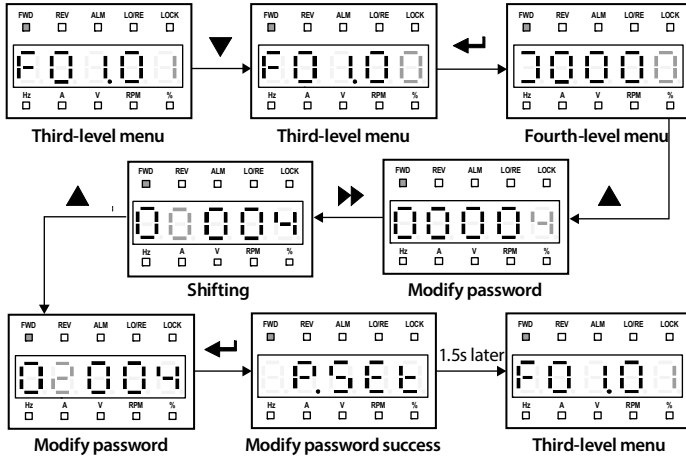

Figure 5-9 Operation of modifying user's password

Clear user's password

If there is password, unlock according to Figure 5-8. When unlock successfully, the keypad displays "F01.01", clear the user's password according to Figure 5-10.

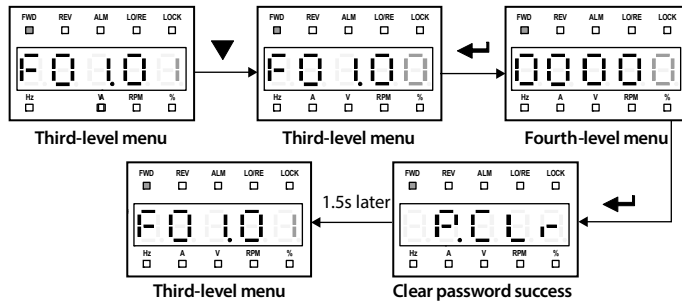
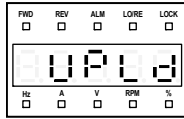

Figure 5-10 Operation of clearing user's password

Parameter copy

The parameters are copied from the control panel to the operator panel:

When F01.03 = 1/2, the keypad will display “UPLd”. When the upload is finished, the keypad will jump to display F01.00.



Copied to keypad

Figure 5-11 Parameter copied to keypad

Parameters are copied from the operator panel to the control board:

When F01.02 = 2/3 or F01.02 = 5/6, the keypad will display “dnLd”. When the download is finished, the keypad will jump to display F01.03.

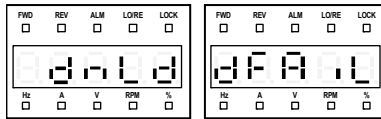

Copied to control board

Copy failed

Figure 5-12 Parameter copied to control board

Note:

- When downloading parameters, it displays “dFAiL” which means that the EEPROM storage parameters of keypad do not match with function parameters of HD30.
First, upload the setting value of the correct function code to the EEPROM of keypad, and then download.
- When copying parameters, the keypad is flashing to display “E0022” which represents that the EEPROM of keypad is fault. It will jump to next function code for 10 seconds later. The troubleshooting is in 7.1 (on page 119).

5.3 Initial Power On

It needs carefully check before power is on. Please wire the inverter according to the specifications supplied by this manual.

After checking the wiring and mains supply voltage, switch on the circuit breaker and the inverter will be initialization. The keypad will display as shown in Figure 5-13.

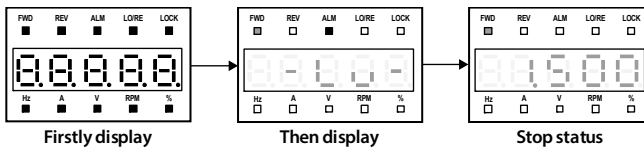

Firstly display

Then display

Stop status

Figure 5-13 Display initialing keypad

Chapter 6 Function Introduction

This chapter will provide user with detail function introduction of each Group.

Display Parameters:

d00: Status Display Parameters (on pages 54 - 57)

General Function Parameters:

- F00: Basic Parameter (on pages 57 - 60)
- F01: Protection of Parameters (on pages 60 - 63)
- F02: Run / Stop Control Parameters (on pages 63 - 65)
- F03: Acc. / Dec. Parameters (on pages 65 - 67)
- F04: Process PID Control (on pages 67 - 70)
- F05: External Reference Curve Parameters (on pages 70 - 72)
- F06: MS SPEED and Simple PLC (on pages 72 - 75)
- F07: Wobble Operation Parameters (on pages 75 - 76)
- F08: Asyn. Motor 1 Parameters (on pages 76 - 78)
- F09: V/f Control Parameters (on pages 78 - 80)
- F10: Motor 1 Vector Control Speed-loop Parameters (on pages 80 - 81)
- F11: Motor 1 Vector Control Current Loop Parameter (on page 81 - 82)
- F13: Asyn. Motor 2 Parameters (on pages 82 - 85)
- F15: Digital I/O Terminal Parameters (on pages 85 - 97)
- F16: Analogue I/O Terminal Parameters (on pages 97 - 101)
- F17: SCI Communication Parameters (on pages 101 - 102)
- F18: Display Control Parameters (on pages 102 - 103)
- F19: Function-boost Parameters (on pages 103 - 111)
- F20: Protection of Fault Parameters (on pages 111 - 115)
- F21: Torque Control Parameters (on pages 115 - 116)
- F23: PWM Control Parameters (on pages 116 - 116)

User Setting Parameters:

Group U: User Menu Mode Display Parameters (on pages 117 - 117)

Manufacturer Function Parameters (on page 117)

Ref. Code	Function Description	Setting Range [Default]
d00.16	Output frequency (Hz)	[Actual value]
d00.17	Setting RPM (rpm)	[Actual value]
d00.18	Running RPM (rpm)	[Actual value]
d00.20	Output voltage (V)	[Actual value]
d00.21	Output current (A)	[Actual value]
d00.22	Torque given (%) Display torque pro-given, the percentage of rated torque.	[Actual value]
d00.23	Output torque (%) Display output torque which is the relative percentage of the motor rated torque.	[Actual value]
d00.24	Output power (kW) Display the present actual output power.	[Actual value]
d00.25	DC bus voltage (V)	[Actual value]
d00.26	Potentiometer input voltage of the keypad (%) Display potentiometer input voltage of the keypad.	[Actual value]
d00.27	A11 input voltage (%) Display A11 input voltage.	[Actual value]
d00.28	A11 input voltage (after disposal) (%) Display A11 input voltage which is disposed by the gain, bias, analogue curve and filter.	[Actual value]
d00.29	A12 input voltage (%) Display A12 input voltage. Display input voltage/current of A12 after handling by filter. <ul style="list-style-type: none"> When A12 selects voltage input, -100.0% corresponds -10V, and 100.0% corresponds 10V. When A12 selects current input, 0.0% corresponds 0mA, and 100.0% corresponds 20mA. 	[Actual value]
d00.30	A12 input voltage (after disposal) (%) Display input voltage/current after gain and bias treatment. <ul style="list-style-type: none"> Coresponding relation see d00.29. 	[Actual value]
d00.31	A13 input voltage (%) Display input voltage/current of A13 after filter. <ul style="list-style-type: none"> Select HD30-EIO extension card, A13 is corresponds A13 of HD30-EIO. <ul style="list-style-type: none"> When A13 selects voltage input, -100.0% corresponds -10V, and 100.0% corresponds 10V. When A13 selects current input, 0.0% corresponds 0mA, and 100.0% corresponds 20mA. Select HD30-PIO extension card, A13 corresponds channel 1 of HD30-PIO card. <ul style="list-style-type: none"> When voltage input is selected as channel 1, 0V corresponds 0.0%, 24V corresponds 100.0%. When current input is selected as channel 1, 0A corresponds 0.0%, 1A corresponds 100.0%. 	[Actual value]
d00.32	A13 input voltage (after disposal) (%) Display A13 input voltage/current after gaining and offseting. <ul style="list-style-type: none"> Coresponding relation see d00.31. 	[Actual value]
d00.33	A14 input voltage (%) Display input voltage/current of A14 after filter. <ul style="list-style-type: none"> Select HD30-EIO extension card, A14 is corresponds A14 of HD30-EIO. <ul style="list-style-type: none"> When A14 selects voltage input, -100.0% corresponds -10V, and 100.0% corresponds 10V. When A14 selects current input, 0.0% corresponds 0mA, and 100.0% corresponds 20mA. Select HD30-PIO extension card, A14 corresponds channel 2 of HD30-PIO card. <ul style="list-style-type: none"> When voltage input is selected as channel 2, 0V corresponds 0.0%, 24V corresponds 100.0%. When current input is selected as channel 2, 0A corresponds 0.0%, 1A corresponds 100.0%. 	[Actual value]

Ref. Code	Function Description	Setting Range [Default]																							
d00.34	A14 input voltage (after disposal) (%)	[Actual value]																							
	Shows the gain, offset after the A14 input voltage / current. • Correspondence is shown in d00.33.																								
d00.35	D16 terminal pulse input frequency (Hz)	[Actual value]																							
d00.36	AO1 output (%)	[Actual value]																							
	When AO1 selects voltage output, 0.0% corresponds 0V, and 100.0% corresponds 10V. When AO1 selects 0 - 20mA current input, 0.0% corresponds 0mA, and 100.0% corresponds 20mA. When AO1 selects 4 - 20mA current input, 0.0% corresponds 4mA, and 100.0% corresponds 20mA. • 4 - 20mA current output parameter setting see F16.22, F16.23.																								
d00.37	AO2 output (%)	[Actual value]																							
	Correspondence is the same as AO1, see d00.36.																								
d00.38	High-speed output pulse frequency (Hz)	[Actual value]																							
d00.39	Heatsink temperature (°C)	[Actual value]																							
d00.40	Setting line speed	[Actual value]																							
d00.41	Reference line speed	[Actual value]																							
d00.44	Process PID reference (%)	[Actual value]																							
	Display process PID reference relative to full scale (10.00V) percentage.																								
d00.45	Process PID feedback (%)	[Actual value]																							
	Display process PID feedback relative to full scale (10.00V) percentage.																								
d00.46	Process PID tolerance (%)	[Actual value]																							
	Display process PID tolerance relative to full scale (10.00V) percentage.																								
d00.47	Process PID integral item (%)	[Actual value]																							
	Display process PID integral item relative to full scale (10.00V) percentage.																								
d00.48	Process PID output (%)	[Actual value]																							
	Display process PID output to full scale (10.00V) percentage.																								
d00.49	External counting value	[Actual value]																							
d00.50	Input terminal status	[Actual value]																							
	Display input terminal status. Each bit (binary) of this function parameter stands for different physical sources which are in the below table. • 0: The input terminals are disconnected with corresponding common terminals. • 1: The input terminals are connected with corresponding common terminals.																								
	<table border="1"> <thead> <tr> <th>Bit11</th> <th>Bit10</th> <th>Bit9</th> <th>Bit8</th> <th>Bit7</th> <th>Bit6</th> <th>Bit5</th> <th>Bit4</th> <th>Bit3</th> <th>Bit2</th> <th>Bit1</th> <th>Bit0</th> </tr> </thead> <tbody> <tr> <td>-</td> <td>-</td> <td>-</td> <td>DI9</td> <td>DI8</td> <td>DI7</td> <td>DI6</td> <td>DI5</td> <td>DI4</td> <td>DI3</td> <td>DI2</td> <td>DI1</td> </tr> </tbody> </table>		Bit11	Bit10	Bit9	Bit8	Bit7	Bit6	Bit5	Bit4	Bit3	Bit2	Bit1	Bit0	-	-	-	DI9	DI8	DI7	DI6	DI5	DI4	DI3	DI2
Bit11	Bit10	Bit9	Bit8	Bit7	Bit6	Bit5	Bit4	Bit3	Bit2	Bit1	Bit0														
-	-	-	DI9	DI8	DI7	DI6	DI5	DI4	DI3	DI2	DI1														
<i>Note: Only when using HD30-EIO will the DI7 - DI9 be enabled.</i>																									
d00.51	Output terminal status	[Actual value]																							
	Display output terminal status. Each bit (binary) of this function parameter stands for different physical sources which are in the below table. • 0: The output terminals are disconnected with corresponding common terminals. • 1: The output terminals are connected with corresponding common terminals.																								
	<table border="1"> <thead> <tr> <th>Bit7</th> <th>Bit6</th> <th>Bit5</th> <th>Bit4</th> <th>Bit3</th> <th>Bit2</th> <th>Bit1</th> <th>Bit0</th> </tr> </thead> <tbody> <tr> <td>-</td> <td>-</td> <td>RLY4</td> <td>RLY3</td> <td>RLY2</td> <td>RLY1</td> <td>DO2</td> <td>DO1</td> </tr> </tbody> </table>		Bit7	Bit6	Bit5	Bit4	Bit3	Bit2	Bit1	Bit0	-	-	RLY4	RLY3	RLY2	RLY1	DO2	DO1							
Bit7	Bit6	Bit5	Bit4	Bit3	Bit2	Bit1	Bit0																		
-	-	RLY4	RLY3	RLY2	RLY1	DO2	DO1																		
<i>Note: Only when using HD30-EIO will the RLY2 - RLY4 be enabled.</i>																									

Ref. Code	Function Description	Setting Range [Default]
d00.52	MODBUS communication status Display MODBUS communication status. 0: Normal. 1: Communication timeout. 4: Incorrect data frame content.	[Actual value]
d00.53	Actual length (m)	[Actual value]
d00.54	Total length (km)	[Actual value]
d00.55	Total time at power-on (h)	[Actual value]
d00.56	Total time at operation (h)	[Actual value]
d00.57	High bit of motor total energy consumption (k km.h)	[Actual value]
d00.58	Low bit of motor total energy consumption (km.h)	[Actual value]
d00.59	High bit of energy consumption at this time running (k km.h)	[Actual value]
d00.60	Low bit of energy consumption at this time running (km.h)	[Actual value]
d00.61	Present fault Displaying 100 means the undervoltage.	[Actual value]

6.2 Group F: General Function Parameters

6.2.1 F00: Basic Parameters

Ref. Code	Function Description	Setting Range [Default]
F00.00	Control mode selection 0: Speed control. 1: Torque control. <ul style="list-style-type: none"> Torque control is valid only when the motor control mode is selected for PG vector control (F00.01 / F13.00 = 2). Refer to Group F15 DI terminal (56, 57) function description and Group F21 torque control parameter description for details of torque control. 	0,1 [0]
F00.01	Motor 1 control mode selection 0: V/f control without PG. Constant voltage/frequency ratio control. <ul style="list-style-type: none"> It is specially applicable for occasions when one inverter drives more than one motors to achieve proper efficiency. When select V/f control, please properly set the V/f control parameter of Group F09 or Group F13 to achieve proper efficiency. 2: Vector control without PG. Sensorless vector control. <ul style="list-style-type: none"> It is applicable for application with high requirement on inverter performance and torque. At first, it must perform motor parameter auto-tuning. And then adjust the settings of F08.00 - F08.04 according to the nameplate of the motor. Start the motor parameter auto-tuning function and properly set Group F10 parameters, so as to achieve excellent vector control efficiency. 	0 - 2 [0]
F00.02	Inverter type setting 0: G type, to drive heavy and general motor. 1: P type, to drive pump and fan.	0,1 [0]
F00.03	Motor selection 0: Motor 1. 1: Motor 2. <i>Note: It can preset two Group motor parameters. At stop they can shift even without input parameters when they are respectively driving two motors.</i>	0,1 [0]

Ref. Code	Function Description	Setting Range [Default]
F00.04	HD30 general extension option selection 0: Option is invalid. 1: HD30-EIO is valid. 3: HD30-PIO is valid. <i>Note: The extension function can be used with the corresponding option.</i>	0 - 3 [0]
F00.06	Inverter max. output frequency It defines the highest frequency that the inverter is allowed to output. <ul style="list-style-type: none"> The max. frequency of V/f control is 400Hz and the max. frequency for vector control is 200Hz. It is necessary to set them according to the nameplate of the controlled motor and actual operating conditions. 	50.00 - 400.00 [50.00Hz]
F00.07	Upper limit of operation frequency setting source It defines the highest frequency that the user is set to operate, and select different setting sources to set the upper limit frequency by F00.07. <ul style="list-style-type: none"> 0: Digital setting. Set the upper limit frequency by F00.08. 1: Analogue input AI setting. See Group F16. 2: Terminal pulse setting. F16.17 sets the max. pulse input frequency according to F00.06 (inverter max. output frequency). 3 - 6: AI1 - AI4 set. 7: Keypad potentiometer setting. 	0 - 7 [0]
F00.08	Upper limit of operation frequency When F00.07 = 0, the upper limit frequency is set by F00.08.	0.00 - F00.06 [50.00Hz]
F00.09	Lower limit of operation frequency Use F00.09 to limit the actual output frequency. When the setting frequency value is bigger than the zero frequency threshold (F19.10) but smaller than F00.09, it will operate at lower limit frequency. <ul style="list-style-type: none"> Please properly set the parameters according to the nameplate of the motor and actual operating conditions. No limitation on the motor parameter auto-tuning function. Besides the lower and upper limit of frequency, the inverter's running frequency is also limited by the parameter settings of start/stop DWELL frequency (F02.02, F02.14), zero frequency threshold (F19.10), stop DC braking starting frequency (F02.16) and skip frequency (F05.17, F05.18, F05.19) etc. 	0.00 - F00.08 [0.00Hz]
F00.10	Frequency setting sources selection 0: Display panel digital setting. Change the value by pressing the ▲ or ▼ key of the keypad. Initial value is set by F00.13. 1: Terminal digital setting. Change the value by using the terminals UP/DN. F00.13 sets initial value. 2: SCI communication setting. Change the setting frequency by SCI communication frequency command. <ul style="list-style-type: none"> The initial value of the SCI communication frequency is 0. 3: AI analogue setting. It is set by the analogue input voltage. <ul style="list-style-type: none"> See Group F16. The corresponding relationship between the analogue value of AI1 and the inverter's running frequency setting is referred to Group F05. 4: Terminal pulse setting. It is set by the terminal pulse DI6. <ul style="list-style-type: none"> Referred to Group F05 for the corresponding relationship between the pulse terminal frequency and the inverter's running frequency setting. 6 - 9: AI1 - AI4 set. 10: Keypad potentiometer setting.	0 - 10 [0]

Ref. Code	Function Description	Setting Range [Default]
F00.11	<p>Command setting source selection</p> <p>0: Display panel running source. Start and stop the inverter by pressing the key RUN STOP, JOG.</p> <p>1: Terminal running source. Start and stop by using the corresponding external terminals.</p> <ul style="list-style-type: none"> External terminal FWD (multi-function terminal is set to 2), REV (multi-function terminal is set to 3), JOGF1 (DI terminal is set to 20), JOGR1 (DI terminal is set to 21), JOGF2 DI terminal is set to 22), JOGR2 (DI terminal is set to 23). For more information please see Group F15. <p>2: SCI communication running source. Start and stop by SCI communication port according to communication protocol.</p>	0 - 2 [0]
F00.12	<p>Function selection of the multi-function key</p> <p>0: Switch the keypad running direction. Switch the keypad running direction by M key.</p> <ul style="list-style-type: none"> When F00.11 = 0, it is valid. Do not save when power is off. The operation direction can only be switched when the operation panel is in the status parameter display. <p>1: Switch local and remote control. Switch the local and remote control by M key.</p> <ul style="list-style-type: none"> LOCAL when running the command channel is keypad command channel (F00.11 = 0). REMOTE When the command channel is a command channel other than keypad (F00.11 = 1, 2). Run command channel priority: Local remote switch > DI terminal (9, 10, 11 function) determine command channel > F00.11 set command channel. <div style="border: 1px dashed black; padding: 10px; margin: 10px 0;"> <p style="text-align: center;">Running command channel</p> <p style="text-align: center;">Determined by both F00.11 and DI terminal</p> <div style="display: flex; justify-content: space-around; align-items: center;"> <div style="border-left: 1px dashed black; border-right: 1px dashed black; padding: 0 5px;">Terminal</div> <div style="border-left: 1px dashed black; border-right: 1px dashed black; padding: 0 5px;">SCI communication</div> </div> <div style="display: flex; justify-content: space-around; align-items: center; margin-top: 10px;"> <div style="border: 1px solid black; padding: 5px;">Terminal</div> <div style="text-align: center;">→ M →</div> <div style="border: 1px solid black; padding: 5px;">Keypad</div> <div style="text-align: center;">→ M →</div> <div style="border: 1px solid black; padding: 5px;">Terminal</div> </div> <div style="display: flex; justify-content: space-around; align-items: center; margin-top: 10px;"> <div style="border: 1px solid black; padding: 5px;">Communication</div> <div style="text-align: center;">→ M →</div> <div style="border: 1px solid black; padding: 5px;">Keypad</div> <div style="text-align: center;">→ M →</div> <div style="border: 1px solid black; padding: 5px;">Communication</div> </div> </div> <p>• LO/RE indicator:</p> <ul style="list-style-type: none"> Lit: Indicates that the current drive is in the terminal running command channel. Blinking: Indicates that the current drive is in the communication run command channel. Off: Indicates that the current drive is in the operator panel running command channel. <p>2: The multi-function key is invalid.</p> <p>3: U group shortcut menu.</p>	0 - 3 [2]
F00.13	<p>Starting frequency digital setting</p> <p>When F00.10 = 0 or 1, F00.13 start to set the initial frequency value.</p>	0.00 - upper limit [50.00Hz]
F00.14	<p>Frequency setting control</p> <p>Only when F00.11 = 0 or 1 will it be valid.</p> <ul style="list-style-type: none"> The current setting frequency value will be replaced by a new one when the value of the F00.13 has been changed by the parameter setting. <div style="display: flex; justify-content: space-between;"> <div style="width: 45%;"> <p>Unit: Frequency setting save selection at power outage</p> <ul style="list-style-type: none"> 0: Not stored when power down. 1: Storage when power down. <p>Ten: Frequency setting control selection at stop</p> <ul style="list-style-type: none"> 0: Set frequency at stop. 1: Set the frequency to F00.13 when stopping. <p>Hundred: Communication setting frequency storage selection</p> <ul style="list-style-type: none"> 0: Not stored when power down. 1: Storage when power down. </div> <div style="width: 45%;"> <p>Thousand: Switch the frequency channel to the analogue selection</p> <ul style="list-style-type: none"> 0: Not saved. 1: Save. When the frequency setting channel is switched from panel setting to terminal digital setting, and then switch back to panel setting, the panel setting frequency remains the last changed frequency. </div> </div>	000 - 111 [1001]

Ref. Code	Function Description	Setting Range [Default]
F00.15	Jog operation frequency digital setting 1	0.00 - upper limit [5.00Hz]
F00.16	Interval of jog operation After cancel the jog command, the inverter will not respond to the jog command at the interval of jog operation set by F00.16. <ul style="list-style-type: none"> After the interval of jog is completed, it immediately execute the arrived jog command. As show in figure. 	0.0 - 100.0 [0.0s]
F00.17	Operation direction selection 0: The same as run command. 1: Opposite to run command.	0,1 [0]
F00.18	Anti-reverse operation This function will be valid when F00.11 = 0,1,2. 0: Reverse operation is permitted. 1: Reverse operation is prohibited. <ul style="list-style-type: none"> The inverter only responds to the forward run command. If the frequency is set to negative at this time, the inverter will run at zero frequency. The inverter does not respond to the reverse command. If the reverse command is received in the operating state, the inverter will stop and stop immediately. When the PLC is running in the reverse direction of the setting section, the inverter will decelerate to zero frequency operation until the positive direction is running. 	0,1 [0]
F00.19	Dead time of direction switch F00.19 defines the dead time of direction switch, namely, the time of zero-frequency output in the process of direction switch shown as the right figure.	0.0 - 3600.0 [0.0s]
F00.20	Key enable of optional keypad 0: Enabled. When the inverter connects to two keypads, the keys of optional display using the communication port can be operated. 1: Invalid. When the inverter connects to two keypads, the keys of optional display using the communication port can not be operated.	0,1 [0]
F00.21	Dormant function selection 0: Disabled. This function is invalid. 1: Enabled.	0,1 [0]
F00.22	Dormancy wake up time	0.0 - 6000.0 [1.0s]
F00.24	Sleep delay time	0.0 - 6000.0 [1.0s]
F00.25	Sleep frequency F00.21 - F00.25 can realize functions of sleep and wake up. <ul style="list-style-type: none"> With running command and it is in sleep state, After setting the frequency \geq F00.25, after the time F00.22 (sleep wake-up time), the inverter will exit the dormant state and start to start. During operation, when set frequency $<$ F00.25, the inverter enters the sleep state (the operation indicator is on and the LED flashes) and stops after the elapsed time F00.24 (sleep delay time). The above sleep function is only valid at F00.11=1 (terminaloperation command channel). 	0.00 - upper limit [0.00Hz]

Ref. Code	Function Description	Setting Range [Default]
F00.26	Action selection for inverter running at zero frequency	000 - 332 [111]
	<p>Unit: When running is controlled by V/f, action selection of zero frequency</p> <ul style="list-style-type: none"> • 0: No treatment. • 1: Inverter lock output. • 2: Inverter run in DC brake. <p>Ten: Zero frequency action selection in open loop vector running</p> <p>Hundred: Zero frequency action selection in torque control</p> <ul style="list-style-type: none"> • 0: No treatment. • 1: Inverter lock output. • 2: Inverter run in DC brake. • 3: The frequency converter is operated by pre-excitation. 	
F00.27	Command source binding frequency source selection	000 - ddd [000]
	<p>Only valid for the main frequency, when the command source has a binding frequency source, the command source is valid, F00.10 the frequency source is invalid.</p> <p>Unit: Panel command binding frequency source selection</p> <p>Ten: Terminal command Binding frequency source selection</p> <p>Hundred: Communication command binding frequency source selection</p> <ul style="list-style-type: none"> • 0: No binding. • 1: Keypa digital setting. • 2: Terminal digital setting. • 3: SCI communicaiton setting. • 5: Terminal pulse setting. • 7: AI1 setting. • 8: AI2 setting. • 9: AI3 setting. • A: AI4 setting. • b: Keypad potentiometer setting. • C: PID setting. • d: Multi-speed setting. 	
F00.28	Functions selection of button STOP	0,1 [0]
	<ul style="list-style-type: none"> 0: Only valid in control of keypad. 1: Valid in all control mode. 	

6.2.2 F01: Protection of Parameters

Ref. Code	Function Description	Setting Range [Default]
F01.00	<p>User's password</p> <p>XXXXX: To enable the password protection function, set any non-zero number as the password.</p> <ul style="list-style-type: none"> Once the password is set, if you want to change any parameter you must input correct password. Otherwise, all the parameters cannot be changed but only read. When input correct password, by pressing the PRG key to exit to stop/run display status or by detecting that there is no press on the keypad within 5 minutes, the user's password will be valid. It is necessary to input correct password if you want to change parameters. It will restart when there is no press on the keypad within 5 minutes. <p>00000: The factory setting of F01.00 is 00000, namely the password protection function is disabled.</p> <ul style="list-style-type: none"> If the user unlocks the password, it means clearing the user's password. To unlock, change and clear the user's password, see section 5.2.3. 	00000 - 65535 [00000]
F01.01	<p>Menu mode selection</p> <p>Unit:</p> <ul style="list-style-type: none"> 0: Full menu mode. All function parameters can be displayed in this menu. 1: Checking menu mode. Only different from factory setting parameters can be displayed. <p>Ten:</p> <ul style="list-style-type: none"> 0: Does not lock the parameter mapping relationship of Group U and Group F. 1: Lock the parameter mapping relationship of Group U and Group F. <p>Hundred:</p> <ul style="list-style-type: none"> 0: After password protection, Group F and U parameters can be read. 1: After password protection, Group F and U parameters are prohibited from reading. 	000 - 111 [010]
F01.02	<p>Function code parameter initialization (download)</p> <p>0: No operation. The inverter is in regular parameter read/write status.</p> <ul style="list-style-type: none"> Whether can change the parameter it depends on the user's password status and the actual operating conditions. <p>1: Restore to factory settings.</p> <ul style="list-style-type: none"> Except F01.00, F01.02, F01.03, Group F08, F13.01 - F13.15, F19.15, F19.19, F19.24, F20.08, F20.09, F20.21 - F20.37, F23.00 and Group y. Operation steps: If set F01.02 = 1, press  to ensure and the parameters are restored to factory settings. The keypad displays "rESEt". Then the keypad will display parameters in stop status after finish restoring to factory setting. <p>2,3: Download the keypad EEPROM parameter 1 / 2 to the current function code settings.</p> <p>4: Clear fault information. The fault history of F20.21 - F20.37 will be clear.</p> <p>5,6: Download the keypad EEPROM parameter 1 / 2 to the current function code settings (including the motor parameters).</p> <p><i>Note: F01.00, F01.02, F01.03, F20.21 - F20.37 and Group y do not upload or download.</i></p>	0 - 6 [0]
F01.03	<p>Display panel EEPROM parameter initialization (upload)</p> <p>0: No operation. The inverter is in regular parameter read/write status.</p> <p>1,2: Upload the current function code settings to the keypad EEPROM parameter 1 / 2.</p> <p><i>Note: F01.00, F01.02, F01.03, F20.21 - F20.37 and Group y do not upload or download.</i></p>	0 - 2 [0]



Download
Keypad stored
function parameter
F01.02 = 2 / 3 / 5 / 6



Upload
HD30 present setting
function parameter
F01.03 = 1/2

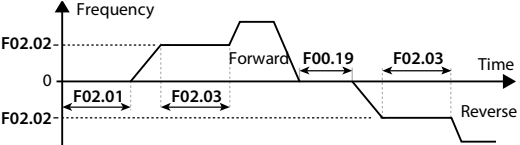
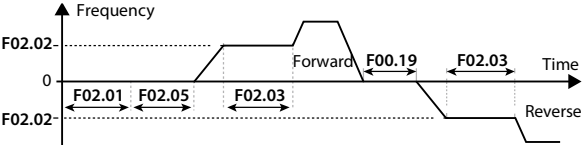
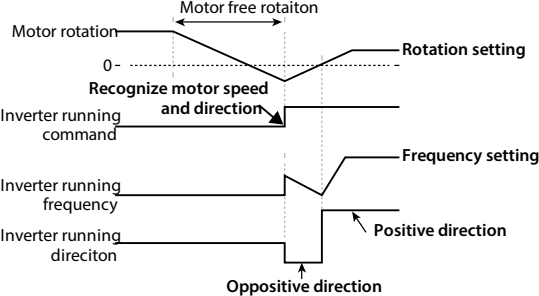

6.2.3 F02: Run / Stop Control Parameters

Ref. Code	Function Description	Setting Range [Default]
F02.00	<p>Start mode selection</p> <p>0: From the DWELL frequency to start.</p> <ul style="list-style-type: none"> Refer to F02.02 and F02.03 parameters for the start DWELL frequency.  <p>1: Brake first and then start from DWELL frequency.</p> <ul style="list-style-type: none"> Refer to F02.04 and F02.05 parameters for the DC braking. Starting DC braking is enabled only in the process from the stop status to running status. But it is disabled in the process of direction switch, as shown in the figure. There is no F02.05 (DC braking time) when reverse.  <p>2: Start after speed tracking. If the result of speed tracking is smaller than F02.02, it will start from the starting DWELL frequency.</p> <ul style="list-style-type: none"> The inverter automatically searches and catches the motor's running direction and speed, and starts the rotating motor smoothly without impact. As the right figure. This mode is enabled only in the process from stop status to running status. But it is disabled in the process of direction switch. 	0 - 2 [0]
F02.01	<p>Starting delay time</p> <p>When the inverter receives the run command, it will wait for the delay time set by F02.01 and then start running.</p>	0.00 - 10.00 [0.00s]

Ref. Code	Function Description	Setting Range [Default]
F02.02	Start DWELL frequency setting	0.00 - upper limit [0.00Hz]
F02.03	Retention time of starting DWELL frequency	0.00 - 10.00 [0.00s]
	<p>When starting, temporarily keep the output frequency to prevent the motor into a stall state.</p> <p>When it is loaded with a brake, when the brake is operating slowly, in order to prevent friction from the brake, use DWELL function to accelerate after the brake is fully opened.</p> <ul style="list-style-type: none"> During Acc., when the given frequency matches the frequency set by F02.02, the output frequency is maintained at the time set in F02.03 and continues to accelerate. Set F02.02 or F02.03 as 0, the starting DWELL frequency is disabled. <p><i>Note: Torque control, process PID / auxiliary set process PID, simple PLC and wobble, DWELL function is invalid.</i></p>	
F02.04	DC braking current setting	0 100 (inverter's rated current) [50%]
F02.05	DC braking time at start	0.00 - 60.00 [0.50s]
	<p>F02.04 is a percentage of the inverter's rated current. To set the current value of the DC braking at start and at stop.</p> <ul style="list-style-type: none"> If setting is higher than fivefold of motor's rated current, the injection current value is fivefold of the motor's rated current. The DC braking current is valid to both start and stop DC braking. <p>F02.05 = 0.0s, there is no DC braking process at start.</p> <ul style="list-style-type: none"> Only when F02.00 = 1 will F02.05 be enabled. 	
F02.06	Faster tracking results compensation value	0.000 - 2.000 [0.000Hz]
F02.13	Stop mode selection	0 - 2 [0]
	<p>0: Dec. to stop.</p> <ul style="list-style-type: none"> After the stop command is received, the inverter reduces its output frequency according to the Dec. time. When the frequency decreases to F02.14 and holds on a time F02.15 set, it will stop. Refer to the parameter F02.14 and F02.15 in the figure. <p>1: Coast to stop.</p> <ul style="list-style-type: none"> After the stop command is received, the inverter stops output immediately and the motor stops under the effects of mechanical inertia. <p>2: Dec. to stop with DC braking.</p> <ul style="list-style-type: none"> After the stop command is received, the inverter reduces its output frequency according to the Dec. time and starts DC braking when its output frequency reaches F02.16 setting frequency. Refers to parameter F02.16 - F02.18 in the figure for the DC braking at stop. Refers to parameter F03.00 - F03.08 for the Dec. time. 	

Ref. Code	Function Description	Setting Range [Default]
F02.14	DWELL frequency setting at stop	0.00 - upper limit [0.00Hz]
F02.15	Retention time of DWELL frequency at stop F02.14 defines inverter's DWELL frequency at stop. F02.15 is a holding time DWELL frequency at stop (F02.14) in inverter stop process. <ul style="list-style-type: none"> Only when F02.13 = 0 will it be enabled. Set F02.14 or F02.15 as 0, DWELL frequency at stop is disabled. 	0.00 - 10.00 [0.00s]
F02.16	DC braking initial frequency at stop	0.00 - 50.00 [0.50Hz]
F02.17	DC braking waiting time at stop	0.00 - 10.00 [0.00s]
F02.18	DC braking time at stop F02.17 is the interval from A to B in the right figure during Dec. stop process. <ul style="list-style-type: none"> The inverter has no output during the waiting time. By F02.17 setting the waiting time, the current overshoot in the initial stage (point B in the figure) of braking can be reduced when the inverter drives a high power motor. By F02.04 setting the DC braking current at stop. F02.18 = 0.00s, there is no DC braking process at stop. <ul style="list-style-type: none"> Only when F02.13 = 2 will F02.16 - F02.18 be enabled. 	0.00 - 60.00 [0.50s]
F02.19	Jog control mode Unit: 0: The jog functions of start and stop mode etc are invalid. <ul style="list-style-type: none"> In jog running, start mode set by F02.00 and stop mode set by F02.13 are invalid. When the jog command is valid, the inverter starts up and running. When the jog command is invalid, the inverter will decelerate and stop. 1: The jog functions of start and stop mode etc are enabled. <ul style="list-style-type: none"> In jog running, inverter will run in start mode set by F02.00 and stop mode set by F02.13. Ten: 0: Terminal jog is not preferred. <ul style="list-style-type: none"> Terminal control operation does not respond to terminal jog command. 1: Terminal jog priority.	00 - 11 [10]
F02.20	Pre-excitation time Pre-excitation effect: Before the motor rotation, establish the motor flux, in order to obtain faster Acc. performance. <ul style="list-style-type: none"> This function only takes effect in open loop vector control mode. It is recommended that F02.20 value be not less than 0.10s. F02.20 = 0.00s, the pre-excitation function is disabled. 	0.00 - 0.50 [0.50s]

6.2.4 F03: Acc. / Dec. Parameters

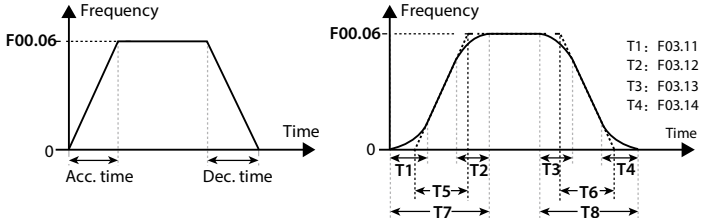
Ref. Code	Function Description	Setting Range [Default]
F03.00	<p>Acc. / Dec. mode selection</p> <p>Unit: Mode selection of Acc. and Dec.</p> <p>0: Linear Acc. or Dec..</p> <ul style="list-style-type: none"> Output frequency increases or decreases according to the constant slope. <p>1: S-curve Acc. or Dec..</p> <ul style="list-style-type: none"> Output frequency increases or decelerases according to the S-curve. T5 is the setting Acc. time, T7 is the actual Acc. time. T6 is the setting Dec. time, T8 is the actual Dec. time.  <p>Ten: Acc. / Dec. time reference frequency adjustment</p> <p>0: Max. frequency (F00.06).</p> <p>1: Set frequency.</p>	00 -11 [00]
F03.01	Acc. time 1	0.1 - 6000.0
F03.02	Dec. time 1	[15kW and below inverter: 10.0s]
F03.03	Acc. time 2	[18.5 - 55kW interter :30.0s]
F03.04	Dec. time 2	[75kW and above inverter: 60.0s]
F03.05	Acc. time 3	
F03.06	Dec. time 3	
F03.07	Acc. time 4	
F03.08	Dec. time 4	
	<p>Acc. time is the time required for inverter to accelerate from zero frequency to the reference frequency in a straight line.</p> <p>Dec. time is the time required for inverter to decrease from the reference frequency to the zero frequency in a straight line.</p> <ul style="list-style-type: none"> The reference frequency can be set by the F03.00 tens digit. The Acc. / Dec. time can only be selected. See the illustration in F03.00. <p>Acc. time, Dec. time switch:</p> <ul style="list-style-type: none"> The Acc. / Dec. time can be selected by 26,27 of DI terminal or F03.09, F03.10 during inverter operation. <p>Acc. / Dec. mode switching:</p> <ul style="list-style-type: none"> The inverter can select the Acc. / Dec. mode (straight line or S curve) by setting F03.00 or DI terminal No. 28 function. <p><i>Note: The inverter may fail overvoltage when the brake assembly is not properly selected, rapid Dec. or load inertia is large. F19.18, F19.19 can be adjusted by selecting the appropriate brake assembly or increasing the Dec. time to avoid possible overvoltage faults.</i></p>	

Ref. Code	Function Description	Setting Range [Default]
F03.09	Switching frequency of Acc. time 2 and time 1	0.00 - upper limit [0.00Hz]
F03.10	Switching frequency of Dec. time 2 and time 1 When the running frequency is smaller than the F03.09 setting, it will accelerate according to Acc. time 2; Otherwise it will accelerate according to Acc. time 1. When the running frequency is smaller than the F03.10 setting, it will decelerate according to Dec. time 2; Otherwise it will decelerate according to Dec. time 1. • When use terminals to select Acc. / Dec. time (set multi-function terminal as number 26 and 27 function), F03.10 is disabled.	0.00 - upper limit [0.00Hz]
F03.11	S-curve characteristic time at starting Acc.	0.00 - 2.50 [0.20s]
F03.12	S-curve characteristic time at ending Acc.	0.00 - 2.50 [0.20s]
F03.13	S-curve characteristic time at starting Dec.	0.00 - 2.50 [0.20s]
F03.14	S-curve characteristic time at ending Dec. Refer to the figure of parameter F03.00.	0.00 - 2.50 [0.20s]
F03.15	Acc. time of jog operation	0.1 - 6000.0 [6.0s]
F03.16	Dec. time of jog operation F03.15 and F03.16 define the Acc. / Dec. time of jog operation.	0.1 - 6000.0 [6.0s]
F03.17	Dec. time of emergency stop It defines the Dec. time of emergency stop.	0.1 - 6000.0 [10.0s]

6.2.5 F04: Process PID Control

Closed-loop can be constituted not only by analogue reference and feedback but also by pulse reference and feedback. Generally, the process PID control mode is used to regulate on-site pressure, liquid level and temperature etc.

The process PID control is shown in the following figure:

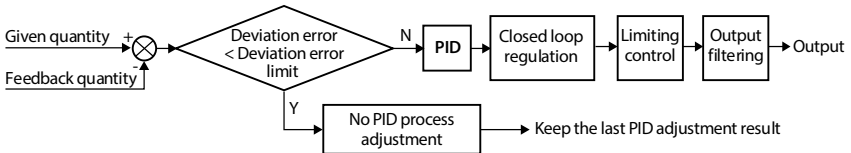

Ref. Code	Function Description	Setting Range [Default]
F04.00	Process PID control selection 0: PID control is disabled. 1: PID control is enabled. <i>Note: When using the auxiliary PID, set F04.00 to 0.</i>	0, 1 [0]
F04.01	Reference source selection 0: Digital reference. It is the value of F04.03 reference. 1: AI analogue reference. It is the value of the analogue input voltage AI reference, and refer to Group F16. 2: Terminal pulse reference. It is the value of the terminal pulse input reference, and max. input pulse frequency corresponding to 10V of the PID reference. 3 - 6: AI1 - AI4 given. 7: Operation panel potentiometer given.	0 - 7 [0]

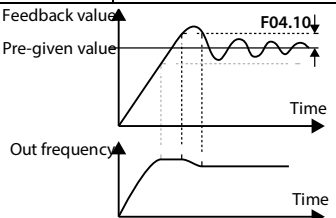
Ref. Code	Function Description	Setting Range [Default]
F04.02	Feedback source selection 0: AI analogue feedback. 1: Terminal pulse feedback. 2: AI1 given. 3: AI2 given. 4: AI3 given. 5: AI4 given. 6: Operation panel potentiometer given. 7: Speedn closed loop feedback.	0 - 7 [0]
F04.03	Setting digital reference It defines the process PID regulator reference. • When F04.01 = 0 (digital reference), it is enabled.	-100.0 - 100.0 [0.0%]
F04.04	Proportional gain (P1)	0.0 - 500.0 [50.0]
F04.05	Integral time (I1)	0.01 - 10.00 [1.00s]
F04.06	Integral upper limit	0.0 - 100.0 [100.0%]
F04.07	Differential time (D1)	0.00 - 10.00 [0.00s]
F04.08	Differential amplitude limit value	0.0 - 100.0 [20.0%]
F04.09	Sampling cycle (T) F04.04, F04.05 and F04.07 define the process PID parameters. F04.06 defines the process PID integral upper limit. F04.08 defines the process PID differential amplitude limit value. F04.09 defines the sampling cycle of feedback value and the PID regulator calculates once in each sampling cycle. • When F04.07 = 0, the differential is disabled.	0.01 - 50.00 [0.10s]
F04.10	Bias limit F04.10 defines the max. deviation of the output from the reference closed-loop. • PID regulator stops operation when the feedback value is within this range. • Setting this parameter correctly is instructive to improve the system output accuracy and stability. • Large setting value of F04.10 may cause the process PID gap to adjust greatly, the whole process system does not converge the shock.	0.0 - 20.0 (reference) [0.0%] 
F04.11	PID regulator upper limit source selection 0: Set by F04.13. 1: Set by AI analogue value. Set by analogue input voltage AI and refer to Group F16. 2: Set by terminal pulse input. 3 - 6: AI1 - AI4 set. 7: Keypad potentiometer setting.	0 - 7 [0]
F04.12	PID regulator lower limit source selection It defines the setting source of PID regulator lower limit value. 0: Set by F04.14. 1: Set by AI analogue value. Set by analogue input voltage AI and refer to Group F16. 2: Set by terminal pulse. 3 - 6: AI1 - AI4 set. 7: Keypad potentiometer setting.	0 - 7 [0]
F04.13	PID regulator upper limit value	0.00 - upper limit [50.00Hz]
F04.14	PID regulator lower limit value	0.00 - upper limit [0.00Hz]
	It defines that the process PID regulator output digital setting value of upper limit or lower limit.	

Ref. Code	Function Description	Setting Range [Default]
F04.15	PID regulator characteristic 0: Positive. The motor RPM is required to increase with the increase of the reference. 1: Negative. The motor RPM is required to decrease with the increase of the reference.	0,1 [0]
F04.17	PID output filter time It defines the filtering time of process PID output.	0.01 - 10.00 [0.05s]
F04.18	PID output reverse selection 0: PID regulation disable reverse. When PID output is negative, 0 is the limit. 1: PID regulation enable reverse. When F00.18 = 1 (disable reverse), 0 is the limit.	0,1 [0]
F04.19	PID output reverse frequency's upper limit It defines the PID upper limit frequency when reverse. • When F04.18 = 1 (PID regulation enable reverse), it is enabled.	0.00 - upper limit [50.00Hz]
F04.20	Proportional gain (P2)	0.0 - 500.0 [50.0]
F04.21	Integral time (I2)	0.01 - 10.00 [1.00s]
F04.22	Derivative time (D2)	0.00 - 10.00 [0.00s]
F04.23	PID parameter adjustment basis 0: Do not adjust. The second segment PID is invalid. 1: DI. • PID parameter switching according to DI terminal function No. 59. When the terminal is invalid, select parameter Group 1 (F04.04, F04.05, F04.07) and select parameter Group 2 (F04.20 - F04.22) when valid. 2: Deviation. • PID parameter selects parameter Group 1 when the deviation between PID feedback and PID reference is less than PID parameter switching point 1 (F04.24). • PID parameter selects parameter Group 2 when the deviation between PID feedback and PID reference is greater than PID parameter switching point 2 (F04.25). • When the deviation between the PID feedback and the PID reference is between the PID parameter switching points 1 and 2, the PID parameter is a linear interpolation of the two sets of parameters. 3: Frequency. • PID parameter selects parameter Group 1 when PID output frequency is less than PID parameter switching point 1 (F04.24). • PID parameter selects parameter Group 2 when PID output frequency is greater than PID parameter switching point 2 (F04.25). • When the PID output frequency is between PID parameter switching points 1 and 2, the PID parameter is a linear interpolation of two sets of parameters.	0 - 3 [0]
F04.24	PID parameter switching point 1	0.0 - F04.25 [0.0%]
F04.25	PID parameter switching point 2	F04.24 - 100.0 [100.0%]
F04.27	Pulse of each turn	1 - 9999 [1024]
F04.28	Max. closed loop speed	1 - 24000 [1500rpm]
F04.29	PID arithmetic mode 0: No operation at stop. 1: Operation at shutdown.	0,1 [0]
F04.30	PID sleep 0: No sleeping. 1: Sleep enable.	0,1 [0]

Ref. Code	Function Description	Setting Range [Default]
F04.31	Tolerance of waking up	0.0 - 100.0 [10.0%]
F04.32	Delay of waking up	0.0 - 6000.0 [0.0s]
	Positive characteristics: sleep state, when the feedback value \leq set value \times (100% - F04.31), and the timing \geq F04.32, wake up the inverter. Negative characteristics: In the sleep state, when the feedback value \geq set value \times (100% + F04.31), and the time \geq F04.32, wake up the inverter.	
F04.33	Sleep tolerance	0.0 - 100.0 [10.0%]
F04.34	Sleep delay	0.0 - 6000.0 [0.0s]
F04.35	Sleep frequency	0.00 - max. frequency [20.00Hz]
	Positive characteristics: wake-up state, when the feedback value \geq given value \times (100% + F04.33), the target frequency \leq F04.35 and the timing time \geq F04.34, the inverter sleep. Negative characteristics: In the wake-up state, when the feedback value is less than or equal to \times (100% - F04.33), the target frequency is \leq F04.35 and the counting time is \geq F04.34. the inverter sleep.	

6.2.6 F05: External Reference Curve Parameters

Ref. Code	Function Description	Setting Range [Default]
F05.00	External reference curve selection	00000 - 33333 [33333]
	Unit: A11 characteristic curve selection Ten: A12 characteristic curve selection Hundred: A13 characteristic curve selection Thousand: A14 characteristic curve selection Ten thousand: Pulse input characteristic curve selection	Each bit setting: • 0: Line 1. • 1: Line 2. • 2: Polyline. • 3: No treatment.
	<i>Note: Only when using HD30-EIO can hundreds and thousands be enabled.</i>	
F05.01	Min. reference of line 1	0.0 - F05.03 [0.0%]
F05.02	Min. reference corresponding value of line 1	0.0 - 100.0 [0.0%]
F05.03	Max. reference of line 1	F05.01 - 100.0 [100.0%]
F05.04	Max. reference corresponding value of line 1	0.0 - 100.0 [100.0%]
F05.05	Min. reference of line 2	0.0 - F05.07 [0.0%]
F05.06	Min. reference corresponding value of line 2	0.0 - 100.0 [0.0%]
F05.07	Max. reference of line 2	F05.05 - 100.0 [100.0%]
F05.08	Max. reference corresponding value of line 2	0.0 - 100.0 [100.0%]
F05.09	Max. reference of polyline	F05.11 - 100.0 [100.0%]
F05.10	Max. reference corresponding value of polyline	0.0 - 100.0 [100.0%]
F05.11	Inflection point 2 reference of polyline	F05.13 - F05.09 [100.0%]
F05.12	Inflection point 2 corresponding value	0.0 - 100.0 [100.0%]
F05.13	Inflection point 1 reference of polyline	F05.15 - F05.11 [0.0%]
F05.14	Inflection point 1 corresponding value	0.0 - 100.0 [0.0%]
F05.15	Min. reference of polyline	0.0 - F05.13 [0.0%]
F05.16	Min. reference corresponding value of polyline	0.0 - 100.0 [0.0%]
	F05.01 - F05.04 define the line 1. F05.05 - F05.08 define the line 2. F05.09 - F05.16 define the polyline. • Line 1, line 2 and polyline can independently achieve positive and negative characteristics as shown in following figure. • If set the curve's min. reference the same as max. reference, it must be a line. The default frequency is the corresponding frequency of the curve min. reference.	

Ref. Code	Function Description	Setting Range [Default]
	<p style="text-align: center;">Positive and negative characteristic of line</p> <p style="text-align: center;">Positive and negative characteristic of polyline</p> <p>In the figure:</p> <ul style="list-style-type: none"> • P/A is terminal pulse / analogue reference. • P (pulse frequency) is 100% corresponding to F16.17 max. input pulse frequency. • A (analogue input value) is 100% corresponding to 10V or 20mA. 	
F05.17	Skip frequency 1	F00.09 - upper limit [0.00Hz]
F05.18	Skip frequency 2	
F05.19	Skip frequency 3	
F05.20	Range of skip frequency	0.00 - 30.00 [0.00Hz]
	<p>The setting of skip frequency is for the inverter's output frequency to avoid resonance with the load.</p> <ul style="list-style-type: none"> • The inverter will skip the above frequencies as shown in figure. Up to 3 skip frequency ranges can be set. • During the process of Acc. / Dec., the inverter will run with continuous frequency output, ignoring the skip frequency ranges. But the inverter will not run at constant speed in the skip frequency ranges. • Frequency setting is uncontinuous, while frequency output is continuous. 	
F05.21	Jog operation frequency digital setting 2	0.00 - upper limit [5.00Hz]
	When select jog operation 2 through terminal, set the jog frequency operation according to F05.21.	
F05.22	Operation panel potentiometer curve selection	0 - 3 [3]
	<p>0: Straight line 1. 1: Straight line 2. 2: Polyline. 3: No treatment.</p>	

6.2.7 F06: MS SPEED and Simple PLC

Ref. Code	Function Description	Setting Range [Default]
F06.00	Multi-step frequency command 1	F00.09 - upper limit [3.00Hz]
F06.01	Multi-step frequency command 2	F00.09 - upper limit [6.00Hz]
F06.02	Multi-step frequency command 3	F00.09 - upper limit [9.00Hz]
F06.03	Multi-step frequency command 4	F00.09 - upper limit [12.00Hz]
F06.04	Multi-step frequency command 5	F00.09 - upper limit [15.00Hz]
F06.05	Multi-step frequency command 6	F00.09 - upper limit [18.00Hz]
F06.06	Multi-step frequency command 7	F00.09 - upper limit [21.00Hz]
F06.07	Multi-step frequency command 8	F00.09 - upper limit [24.00Hz]
F06.08	Multi-step frequency command 9	F00.09 - upper limit [27.00Hz]
F06.09	Multi-step frequency command 10	F00.09 - upper limit [30.00Hz]
F06.10	Multi-step frequency command 11	F00.09 - upper limit [33.00Hz]
F06.11	Multi-step frequency command 12	F00.09 - upper limit [36.00Hz]
F06.12	Multi-step frequency command 13	F00.09 - upper limit [39.00Hz]
F06.13	Multi-step frequency command 14	F00.09 - upper limit [42.00Hz]
F06.14	Multi-step frequency command 15	F00.09 - upper limit [45.00Hz]
They define the initial value of each step speed in multi-step speed mode and PLC operation mode.		
F06.15	Simple PLC control selection	0,1 [0]
0: No PLC operation. 1: Enabling PLC operation. It need reset the value of F06.16 - F06.46 according to actual operation.		
F06.16	Simple PLC operation mode selection	0000 - 1122 [0000]
There are 4 parameter settings: units (0 - 2), tens (0 - 2), hundreds (0,1), thousands (0,1). Unit: PLC operation mode selection (taking 15-step PLC for example) <ul style="list-style-type: none"> 0: Stop after single cycle operation. The inverter stops automatically after one operating cycle. It will start only after receiving the run command next time. 		
<ul style="list-style-type: none"> 1: Maintain the final value after single cycle of PLC operation. The inverter will maintain the run frequency and direction of the last step after completing one operating cycle. 		

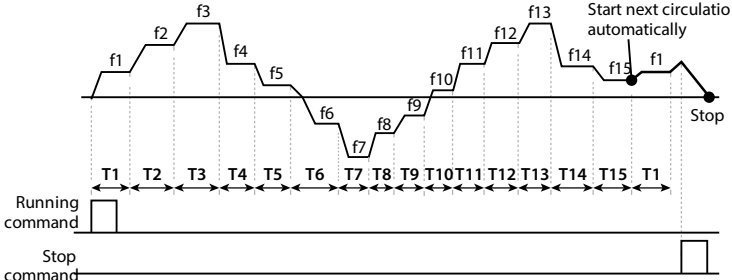
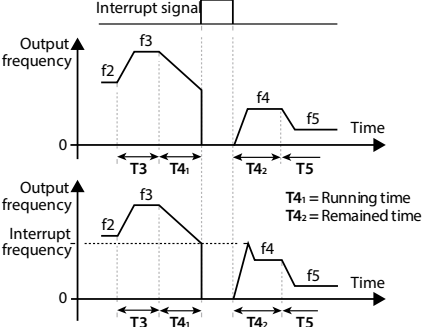
Ref. Code	Function Description	Setting Range [Default]
	<p>• 2: Cycle operation. The inverter will operate with a new cycle from Step 1 automatically after completing one operating cycle until receiving the stop command.</p>  <p>Ten: PLC operation restart mode selection after pause</p> <ul style="list-style-type: none"> • 0: Start from step 1. <ul style="list-style-type: none"> • If the inverter stops during PLC operation due to the stop command, fault or power failure, the PLC operation will start from the Step 1 next time. • 1: Continue to operate from the step where the inverter pauses. <ul style="list-style-type: none"> • If the inverter stops during PLC operation due to the stop command or fault, it will record the uptime. • When it restarts, the inverter will continue operation from the step where it pauses as shown in figure. • 2: Continue to operate at the frequency when the inverter pauses. <ul style="list-style-type: none"> • When the inverter stops during PLC operation due to the stop command or fault, it will record not only the operated time but also the current frequency. • It will continue to operate at the recorded frequency upon restart, as shown in figure. <p><i>Note: The difference between Mode 1 and Mode 2 is that Mode 2 also memorizes the running frequency when the inverter pauses, and the inverter will continue to operate at the frequency upon restart.</i></p> <p>Hundred: Save the PLC status after power failure</p> <ul style="list-style-type: none"> • 0: Not save. The PLC running status will not be saved after power failure and start running from Step 1 next time. • 1: Save. The operating parameters of PLC operation, including the operating step, operating frequency and operating time of this step, etc, can be saved. The inverter will continue to operate in accordance with the PLC operation restart mode selection after pause (defined by tens of F06.16). <p>Thousand: Time unit selection of the PLC step</p> <ul style="list-style-type: none"> • 0: Second (s). • 1: Minute (m). 	
F06.17	Setting of PLC step 1	000 - 321 [000]
F06.19	Setting of PLC step 2	000 - 321 [000]
F06.21	Setting of PLC step 3	000 - 321 [000]
F06.23	Setting of PLC step 4	000 - 321 [000]
F06.25	Setting of PLC step 5	000 - 321 [000]

Ref. Code	Function Description	Setting Range [Default]
F06.27	Setting of PLC step 6	000 - 321 [000]
F06.29	Setting of PLC step 7	000 - 321 [000]
F06.31	Setting of PLC step 8	000 - 321 [000]
F06.33	Setting of PLC step 9	000 - 321 [000]
F06.35	Setting of PLC step 10	000 - 321 [000]
F06.37	Setting of PLC step 11	000 - 321 [000]
F06.39	Setting of PLC step 12	000 - 321 [000]
F06.41	Setting of PLC step 13	000 - 321 [000]
F06.43	Setting of PLC step 14	000 - 321 [000]
F06.45	<p>Setting of PLC step 15</p> <p>F06.17, F06.19, F06.21, F06.23, F06.25, F06.27, F06.29, F06.31, F06.33, F06.35, F06.37, F06.39, F06.41, F06.43, F06.45 are used to configure the running frequency, the direction, Acc. and Dec. time of every PLC step.</p> <p>Unit: PLC running frequency selection</p> <ul style="list-style-type: none"> • 0: Multi-step frequency command. The absolute value of each step frequency is the same as the setting of multi-step frequency. <ul style="list-style-type: none"> • Example: the absolute value of running frequency in PLC Step 15 is the setting value of F06.14. • 1: Depend on F00.10. The running frequency source selects the reference by F00.10 selection. <p>Ten: Operation direction selection of PLC at different steps</p> <ul style="list-style-type: none"> • 0: Forward. • 1: Reverse. • 2: Depend on run command. The motor's operation direction can be alternated via external direction command. <ul style="list-style-type: none"> • If the direction is not set, the inverter will run in the direction according to last step. <p>Hundred: Acc. / Dec. time selection of PLC at different steps</p> <ul style="list-style-type: none"> • 0: Acc. / Dec. time 1. • 1: Acc. / Dec. time 2. • 2: Acc. / Dec. time 3. • 3: Acc. / Dec. time 4. 	000 - 321 [000]
F06.18	Running time of step 1	0.0 - 3276.7 [5.0]
F06.20	Running time of step 2	0.0 - 3276.7 [0.0]
F06.22	Running time of step 3	0.0 - 3276.7 [0.0]
F06.24	Running time of step 4	0.0 - 3276.7 [0.0]
F06.26	Running time of step 5	0.0 - 3276.7 [0.0]
F06.28	Running time of step 6	0.0 - 3276.7 [0.0]
F06.30	Running time of step 7	0.0 - 3276.7 [0.0]
F06.32	Running time of step 8	0.0 - 3276.7 [0.0]
F06.34	Running time of step 9	0.0 - 3276.7 [0.0]
F06.36	Running time of step 10	0.0 - 3276.7 [0.0]
F06.38	Running time of step 11	0.0 - 3276.7 [0.0]
F06.40	Running time of step 12	0.0 - 3276.7 [0.0]
F06.42	Running time of step 13	0.0 - 3276.7 [0.0]
F06.44	Running time of step 14	0.0 - 3276.7 [0.0]
F06.46	<p>Running time of step 15</p> <p>F06.18, F06.20, F06.22, F06.24, F06.26, F06.28, F06.30, F06.32, F06.34, F06.36, F06.38, F06.40, F06.42, F06.44, F06.46 define the running time of PLC at different steps.</p> <ul style="list-style-type: none"> • When set the running time to 0 at some step, it means that the PLC function of this step is disabled. 	0.0 - 3276.7 [0.0]

6.2.8 F07: Wobble Operation Parameters

The wobble operation process is shown as below:

First, the inverter accelerates to the preset frequency of wobble operation (F07.02) within the Acc. time and then waits for certain time (F07.03). Hitherher the inverter transits to the central frequency of the wobble operation as per the Acc. time, and ultimately start wobble operation according to the preset wobble amplitude (F07.04), jump frequency (F07.05), wobble cycle (F07.06) and the rise time of wobble operation (F07.07) until it receives a stop command and stops as per the Dec. time.

The process is shown in figure:

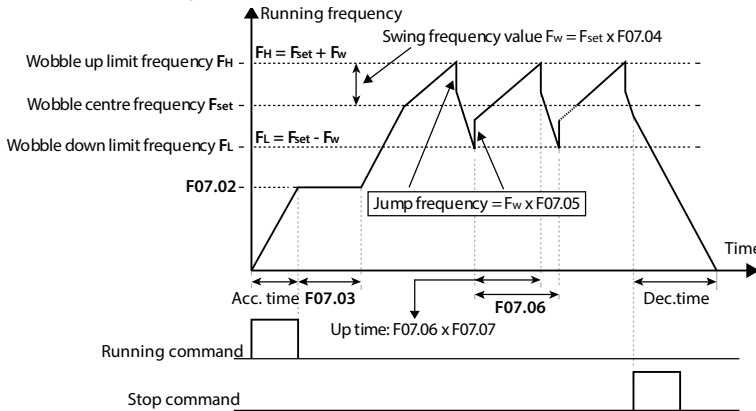

Ref. Code	Function Description	Setting Range [Default]
F07.00	Wobble operation selection	0,1 [0]
	0: Disabled. 1: Enabled.	
F07.01	Wobble operation mode	0000 - 1111 [0000]
	<p>Unit: Start mode of wobble operation</p> <ul style="list-style-type: none"> 0: Auto start. The inverter will first operate at the preset frequency of wobble operation (F07.02) for certain time (F07.03), and then enter wobble mode automatically. 1: Manual start. If the multi-function terminal is set as No.36 function (set as wobble start function) and the signal is enabled, the inverter will enter wobble mode. If the terminal is disabled, the inverter will end wobble operation and operate at the preset frequency of wobble operation (F07.02). <p>Ten: Wobble operation amplitude. Refer to parameter F07.04.</p> <ul style="list-style-type: none"> 0: Relative to the wobble central frequency. 1: Relative to the max. output frequency. <p>Hundred: Restart mode of wobble operation</p> <ul style="list-style-type: none"> 0: The inverter restarts the wobble operation as per the recorded frequency and direction when it stops last time. 1: The inverter restarts the wobble operation from 0Hz. <p>Thousand: Save the wobble operation parameters at power outage</p> <ul style="list-style-type: none"> 0: Saved. When the hundreds of F07.01 is set as 0, the wobble operation parameters will be saved when power outage occurs. 1: Not be saved. 	

Ref. Code	Function Description	Setting Range [Default]
F07.02	Preset wobble frequency	0.00 - upper limit [0.00Hz]
F07.03	Holding time of preset wobble frequency	0.0 - 999.9 [0.0s]
	F07.02 defines the inverter's running frequency before entering wobble mode. F07.03 defines the time that the inverter operates at the preset wobble frequency. • Only when select auto start (set units of F07.01 as 0) will F07.03 be enabled.	
F07.04	Wobble amplitude	0.0 - 50.0 [0.0%]
	Relative to central frequency: $F_w = \text{central frequency} \times F07.04$. • Wobble central frequency is the frequency value set by F00.10 (frequency reference source). Relative to max. output frequency: $F_w = \text{max. output frequency} F00.06 \times F07.04$.	
F07.05	Jump frequency	0.0 - F07.04 [0.0%]
	The setting is the percentage of wobble amplitude. There is not jump frequency if set as 0.	
F07.06	Wobble operation cycle	0.1 - 999.9 [10.0s]
	F07.06 defines a complete cycle of wobble operation including rising and falling processes.	
F07.07	Rising time of triangle wave	0.0 - 100.0 [50.0%]
	Relative to wobble operation cycle of the F07.06, F07.07 defines the rising and the falling time of wobble operation and their unit is s. • Rising time of wobble operation = $F07.06 \times F07.07$. • Falling time of wobble operation = $F07.06 \times (1 - F07.07)$.	

6.2.9 F08: Asyn. Motor 1 Parameters

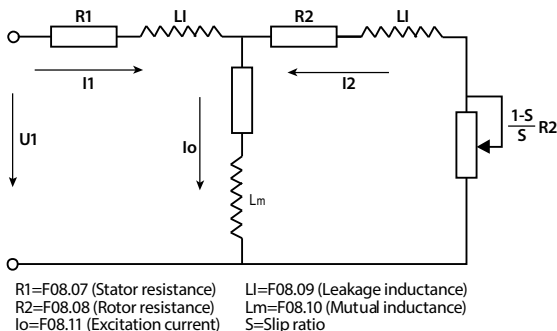

Mutual inductance is calculated by the following formula:

$$\text{Mutual inductance } F08.10 = \frac{F08.01}{2\sqrt{3}\pi \times F08.03 \times F08.11} - F08.09$$

Note: Except F08.03, F08.04 and F08.06, the other factory settings are depended on the inverter's model.

Ref. Code	Function Description	Setting Range [Default]	
F08.00	Rated power of motor 1	0.2 - 999.9kW [Depend on HD30]	
F08.01	Rated voltage of motor 1	0 - 999V [Depend on HD30]	
F08.02	Rated current of motor 1	5.5kW above motor	0.1 - 2500.0A [Depend on HD30]
		5.5kW and below motor	0.01 - 250.00A [Depend on HD30]
F08.03	Rated frequency of motor 1	1.0 - 400.0 [50.0Hz]	
F08.04	Rated RPM of motor 1	1 - 24000 [1500rpm]	
	F08.03 and F08.04 should be set in accordance with the parameters of motor nameplate.		

Ref. Code	Function Description	Setting Range [Default]	
F08.05	Power factor of motor 1	0.001 - 1.000 [Depend on HD30]	
F08.06	Parameter auto-tuning of motor 1	0 - 3 [0]	
<p><i>Note: The auto-tuning is enabled only in keypad control mode (F00.11 = 0).</i></p> <p>0: Auto-tuning is disabled.</p> <p>1: Stationary auto-tuning.</p> <ul style="list-style-type: none"> In the process of stationary auto-tuning, the motor is at rest. The stator resistance, rotor resistance and leakage inductance will be measured and written into F08.07, F08.08 and F08.09 automatically. <p>2: Rotary auto-tuning.</p> <ul style="list-style-type: none"> In process of rotary auto-tuning, the motor is at rest at the beginning, and the stator resistance, rotor resistance and leakage inductance will be measured. After the motor will start rotating, accordingly mutual inductance and idling exciting inductance will be measured automatically. All the measured values above will be saved respectively in F08.07, F08.08, F08.09, F08.10 and F08.11. When the motor is in rotating status, oscillation, even overcurrent, might occur. In this case, please press the STOP key to stop auto-tuning and then adjust the F09.15 (oscillation-suppression mode) and F09.16 (oscillation-suppression factor) suitably to mitigate the possible oscillation. <p>3. Motor stator resistance measurement.</p> <ul style="list-style-type: none"> The motor is at rest, and the stator resistance of the motor is automatically measured and the measured parameters are automatically written to F08.07. <p>Auto-tuning procedures:</p> <ol style="list-style-type: none"> Input correctly the motor parameters as per its nameplate (F08.00 - F08.04). When F08.06 is set as 2, please set the proper Acc. time 1 (F03.01) and Dec. time 1 (F03.02) and make sure the motor is disconnected with the load for security. Set F08.06 as 1 or 2 firstly, then press the ← key, and therewith press RUN key to start auto-tuning. The LED will display "tunE". When the RUN indicator is flashing, it indicates that auto-tuning has been completed. At this time, the inverter displays the parameters of stop status and F08.06 resets to 0. 			
F08.07	Stator resistance of motor 1	5.5kW below motor	0.00 - 99.99Ω [Depend on HD30]
		7.5 - 75kW motor	0.000 - 9.999Ω [Depend on HD30]
		90kW and above motor	0.0000 - 0.9999Ω [Depend on HD30]
F08.08	Rotor resistance of motor 1	5.5kW below motor	0.00 - 99.99Ω [Depend on HD30]
		7.5 - 75kW motor	0.000 - 9.999Ω [Depend on HD30]
		90kW and above motor	0.0000 - 0.9999Ω [Depend on HD30]
F08.09	Leakage inductance of motor 1	5.5kW below motor	0.0 - 5000.0mH [Depend on HD30]
		7.5 - 75kW motor	0.00 - 500.00mH [Depend on HD30]
		90kW and above motor	0.0000 - 50.000 mH [Depend on HD30]
F08.10	Mutual inductance of motor 1	5.5kW below motor	0.0 - 5000.0mH [Depend on HD30]
		7.5 - 75kW motor	0.00 - 500.00mH [Depend on HD30]
		90kW and above motor	0.000 - 50.000 mH [Depend on HD30]
F08.11	Idling exciting current of motor 1	5.5kW and below motor	0.0 - 999.9A [Depend on HD30]
		5.5kW above motor	0.00 - 99.99A [Depend on HD30]
F08.12	Motor 1 core saturation coefficient 1	0.00 - 1.00 [1.00]	
F08.13	Motor 1 core saturation coefficient 2	0.00 - 1.00 [1.00]	
F08.14	Motor 1 core saturation coefficient 3	0.00 - 1.00 [1.00]	
F08.15	Motor 1 core saturation coefficient 4	0.00 - 1.00 [1.00]	
F08.16	Motor 1 core saturation coefficient 5	0.00 - 1.00 [1.00]	

6.2.10 F09: V/f Control Parameters

Ref. Code	Function Description	Setting Range [Default]
F09.00	<p>V/f curve selection of motor 1</p> <p>It defines flexible V/f setting modes so as to meet requirements of different load characteristics.</p> <ul style="list-style-type: none"> Four preset curves and one user-defined curve can be selected according to the setting of F09.00. <p>0: Line. Shown as curve 0 in figure. 1: Square curve. Shown as curve 1 in the figure. 2: 1.2 exponential curve. Shown as curve 2 in the figure. 3: 1.7 exponential curve. Shown as curve 3 in the figure. 4: User-defined curve.</p>	0 - 4 [0]
F09.01	V/f frequency value F3 of motor 1	F09.03 - 100.0 [80.0%]
F09.02	V/f voltage value V3 of motor 1	F09.04 - 100.0 [80.0%]
F09.03	V/f frequency value F2 of motor 1	F09.05 - F09.01 [50.0%]
F09.04	V/f voltage value V2 of motor 1	F09.06 - F09.02 [50.0%]
F09.05	V/f frequency value F1 of motor 1	0.0 - F09.03 [0.0%]
F09.06	<p>V/f voltage value V1 of motor 1</p> <p>F09.01 - F09.06 is the user-definable V/f curve.</p> <ul style="list-style-type: none"> If F09.00 = 4 (user-definable curve), F09.06 is enabled. The V/f curve can be defined by connecting 3 points of (V1, F1), (V2, F2) and (V3, F3), to adapt to special load. According to the actual operation, set proper curve to meet the requirements of load characteristics. 	0.0 - F09.04 [0.0%]
F09.07	Torque boost of motor 1	0.0 - 30.0 [45kW and below inverter: 2.0%] [55 - 132kW inverter: 1.0%] [160kW and above inverter: 0.5%]
F09.08	<p>Cut-off point used for manual torque boost of motor 1</p> <p>In order to compensate the torque drop at low frequency, the inverter can boost the voltage so as to boost the torque.</p> <ul style="list-style-type: none"> Torque boost is valid at any value of F09.00 for V/f curve. When F09.07 ≠ 0, it indicates the manual torque boost mode. When F09.07 = 0, it indicates the automatic torque boost mode. Set the rated motor speed (F08.03) according to the motor nameplate parameter. Obtain rated rpm (F08.04) by rotation auto-tuning; and obtain the exact motor stator resistance (F08.07) by auto-tuning. Set the slip compensation gain F09.09 = 100.0%, to enable slip compensation to obtain a good load capacity. F09.08 is relative to percentage of motor's rated frequency (F08.03). 	0.0 - 50.0 (F08.03) [25.0%]
F09.09	Slip compensation gain of motor 1	0.0 - 300.0 [0.0%]
F09.10	Slip compensation filter time of motor 1	0.01 - 10.00 [0.10s]

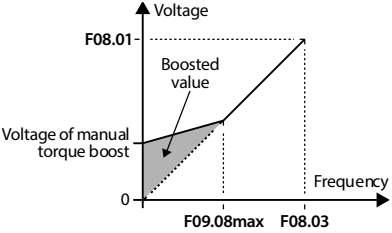
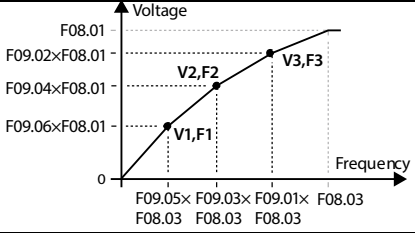
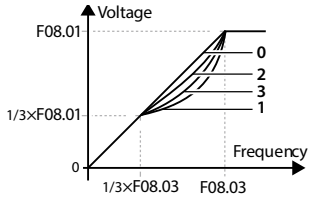

Ref. Code	Function Description	Setting Range [Default]
F09.11	Slip compensation limitation of motor 1 The motor slip changes with the load torque, which results in the variance of motor speed. Reduce the influence through slip compensation. <ul style="list-style-type: none"> Electric and generating state can increase slip compensation gain (F09.09). Slip compensation limit is fixed value within constant torque. It increases in proportion to output frequency within constant power. Auto slip compensation depends on rated slip of motor. User should properly set rated frequency (F08.03) and rated Rpm (F08.04). Range of slip compensation = actual slip compensation limit × rated slip.	0.0 - 250.0 [200.0%]
F09.12	Motor 1 iron loss V/f is used when the torque compensation is controlled. It is determined in default according to the rated power of the motor. Normally, no change is required. F09.12 is set to this value if the accurate iron loss value can be obtained from the motor test report.	0.000 - 9.999kW [Depend on HD30]
F09.14	AVR (automatic voltage regulation) function of motor 1 0: Disabled. 1: Enabled all the time. 2: Disabled in Dec. process. <ul style="list-style-type: none"> The output voltage can be regulated to maintain constant via AVR. Thus, normally the AVR function should be enabled, especially when the input voltage is higher than the rated voltage. In Dec. process, if the F09.14 = 0 or F09.14 = 2, the running current will be a little higher; while if the F09.14 = 1, the motor will decelerate steadily and the current will be smaller. 	0 - 2 [1]
F09.15	Motor 1 low frequency suppression shock coefficient	0 - 200 [50]
F09.16	Motor 1 high frequency suppression shock coefficient It is used to suppress the natural oscillation generated when the inverter is engaged with the motor. <ul style="list-style-type: none"> If the output current changes repeatedly during constant load operation, the oscillation can be eliminated by adjusting the corresponding coefficient to allow the motor to run smoothly. 	0 - 200 [20]
F09.17	Motor 1 energy saving control select 0: Energy saving control invalid. 3: Energy saving according to output current. When F09.17 = 3 and V/f control mode (F00.01 = 0). <ul style="list-style-type: none"> When the output frequency ≥ F09.19 and the output current ≤ F09.20 × inverter rated current, enter the energy saving mode. If any of the above conditions are not currently met, the drive will exit the power saving mode. <i>Note: The power saving mode is only valid at constant speed.</i>	0 - 3 [0]
F09.18	Motor 1 energy saving factor	0.0 - 100.0 [5.0%]
F09.19	Motor 1 energy start frequency	0.00 - 50.00 [25.00Hz]
F09.20	Motor 1 energy switching point	0.0 - 100.0 [100.0%]
F09.21	Motor 1 energy saving detecting times	0 - 5000 [10 times]
F09.22	Motor 1 energy voltage recovery time	40 - 4000 [100ms]
F09.23	Motor 1 energy voltage decreasing time	40 - 4000 [100ms]

6.2.11 F10: Motor 1 Vector Control Speed-loop Parameters

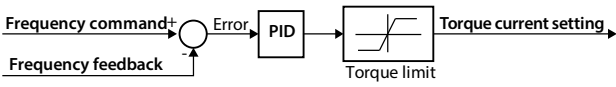
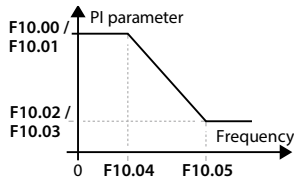
Ref. Code	Function Description	Setting Range [Default]
F10.00	Speed control proportional gain 1 of motor 1	0.1 - 200.0 [10.0]
F10.01	Speed control integral time 1 of motor 1	0.00 - 10.00 [0.10s]
F10.02	Speed control proportional gain 2 of motor 1	0.1 - 200.0 [10.0]
F10.03	Speed control integral time 2 of motor 1	0.00 - 10.00 [0.20s]
F10.04	Speed-loop PI switching frequency 1 of motor 1	0.00 - F10.05 [10.00Hz]
F10.05	Speed-loop PI switching frequency 2 of motor 1	F10.04 - 50.00 [15.00Hz]
<p>F10.00 - F10.05 and F10.07 confirm the PID parameters of automatic speed regulator (ASR). The structure of ASR is shown in figure.</p>  <p>As the right figure:</p> <ul style="list-style-type: none"> • When inverter operates within 0 - F10.04, the PI parameters of vector control are F10.00 and F10.01. • When inverter operates above F10.05, the PI parameters of vector control are F10.02 and F10.03. • When inverter operates within F10.04 - F10.05, P is the linear interpolation between F10.00 and F10.02, while I is the linear interpolation between F10.01 and F10.03. • The system's response can be expedited through increasing the ASR proportional gain P, but oscillation may occur if the value of P is too high. • The system's response can be expedited through increasing the ASR integral constant Ti, but oscillation and high overshoot happen easily if the value of Ti is too high. <ul style="list-style-type: none"> • If Ti = 0, the integral function is disabled and the speed-loop works only as a proportional controller. • Generally, the proportional gain P should be adjusted firstly to the max. on condition that the system does not vibrate, and then the integral constant Ti should be adjusted to shorten the response time without overshoot. • It need increase proportional gain (P) and decrease integral constant (Ti), on condition that shorter dynamic response time is required during low frequency operation. 		
F10.06	Speed-loop integral limitation of motor 1	0.0 - 200.0 (F08.02) [180.0%]
It is used to limit the max. value of the vector control speed-loop integral.		
F10.07	Speed-loop differential time of motor 1	0.00 - 1.00 [0.00s]
It defines the vector control speed-loop differential time.		
<ul style="list-style-type: none"> • Generally, it doesn't need to set F10.07 except for expediting the dynamic response. • There is not the speed-loop differential when F10.07 = 0. 		
F10.08	Speed-loop output filter time of motor 1	0.000 - 1.000 [0.020s]
It is used to filter the output of ASR regulator.		
<ul style="list-style-type: none"> • When F10.08 = 0, the speed-loop filter is disabled. 		
F10.09	Motor 1 torque limit lock selection	0,1 [0]
0: Do not lock.		
1: All of the torque limit is same with FWD electric torque limit.		

Ref. Code	Function Description	Setting Range [Default]
F10.10	Motor 1 Torque limit channel	0000 - 7777 [0000]
	Define the setting channel of torque value. Unit: Forward rotation electric torque limit channel Ten: Reverse electric torque limit channel Hundred: Forward rotation torque limit channel Thousand: Reverse rotation torque limit channel <ul style="list-style-type: none"> • 0: Number limit. • 1: Analog input limit. • 2: Terminal pulse limit. • 3 - 6: AI1 - AI4 limit. • 7: Keypad potentiometer is limited. 	
F10.11	Motor torque limitation when motor 1 is forward	0.0 - 200.0 (F08.02) [180.0%]
F10.12	Motor torque limitation when motor 1 is reverse	
F10.13	Recreated torque limitation when motor 1 is forward	
F10.14	Recreated torque limitation when motor 1 is reverse	

6.2.12 F11: Motor 1 Vector Control Current Loop Parameter

Ref. Code	Function Description	Setting Range [Default]
F11.00	Motor 1 current loop KP	1 - 2000 [400]
F11.01	Motor 1 current loop KI	1 - 1000 [200]
	Defines the PI parameters for a given current loop regulator (ACR). <ul style="list-style-type: none"> • Normally, it is recommended not to adjust the current loop parameters. 	
F11.02	Motor 1 current loop output filter times	0 - 31 [3]
	The output of the current loop regulator is filtered.	
F11.03	Motor 1 current loop feedforward enabled	0,1 [0]
	The output voltage feedforward of current loop feedforward is calculated in real time based on the motor parameters and the detected field current and torque current. <ul style="list-style-type: none"> • When the motor parameters are accurate, the current loop feedforward can boost the dynamic response of the entire system. • When the motor parameters are not accurate, please disable the current loop feedforward. 0: Feedforward is prohibited. 1: Enable feedforward.	
F11.04	Motor 1 excitation boost setting	0.0 - 30.0 [0.0%]
	Setting range 0.0 - 30.0% motor no-load excitation current. Motor load frequency within the rated frequency range, improve the motor carrying capacity by increasing the motor excitation current.	
F11.05	Motor 1 field orientation optimization setting	00 - 11 [00]
	Unit: Field orientation angle correction enable <ul style="list-style-type: none"> • 0: Field orientation correction is forbidden. • 1: Enables magnetic field orientation correction. Ten: Mutual inductance projections enabled <ul style="list-style-type: none"> • 0: Disable mutual inductance based on flux calculation. • 1: Enable mutual inductance based on flux calculation. 	

6.2.13 F13: Asyn. Motor 2 Parameters

This Group can be set as the second Group of motor parameters and control parameters corresponding to the first Group parameters (motor 1). The concrete meaning refers the corresponding parameters of motor 1 and achieves flexible switching between the 2 motors (refer to DI terminal No. 47 function).

Note:

Check F08: Asyn. Motor 1 Parameters for F13.01 - F13.15, F13.53, F13.54.

Check F09: V/f Control Parameters for F13.16 - F13.34, F13.58 - F13.62.

Check F10: Motor 1 Vector Control Speed-loop Parameters for F13.35 - F13.49.

Check F11: Motor 1 Vector Control Current Loop Parameter for F13.50 - F13.52, F13.55 - F13.57.

Ref. Code	Function Description	Setting Range [Default]	
F13.00	Control mode selection of motor 2	0 - 2 [0]	
	0: V/f control without PG. 2: Vector control without PG.		
F13.01	Rated power of motor 2	0.2 - 999.9kW [Depend on HD30]	
F13.02	Rated voltage of motor 2	0 - 999V [Depend on HD30]	
F13.03	Rated current of motor 2	5.5kW above motor	0.1 - 2500.0A [Depend on HD30]
		5.5kW and below motor	0.01 - 250.00A [Depend on HD30]
F13.04	Rated frequency of motor 2	1.0 - 400.0[50.0Hz]	
F13.05	Rated RPM of motor 2	1 - 24000 [Depend on HD30]	
F13.07	Parameter auto-tuning of motor 2	0 - 3 [0]	
	0: No action. 1: Stationary auto-tuning. 2: Rotary auto-tuning. 3: Motor stator resistance measurement.		
F13.08	Stator resistance of motor 2	5.5kW below motor	0.00 - 99.99Ω [Depend on HD30]
		7.5 - 75kW motor	0.000 - 9.999Ω [Depend on HD30]
		90kW and above motor	0.0000-0.9999Ω [Depend on HD30]
F13.09	Rotor resistance of motor 2	5.5kW below motor	0.00 - 99.99Ω [Depend on HD30]
		7.5 - 75kW motor	0.000 - 9.999Ω [Depend on HD30]
		90kW and above motor	0.0000-0.9999Ω [Depend on HD30]
F13.10	Leakage inductance of motor 2	5.5kW below motor	0.0 - 5000.0mH [Depend on HD30]
		7.5 - 75kW motor	0.00 - 500.00mH [Depend on HD30]
		90kW and above motor	0.000 - 50.000 mH [Depend on HD30]
F13.11	Mutual inductance of motor 2	5.5kW below motor	0.0 - 5000.0mH [Depend on HD30]
		7.5 - 75kW motor	0.00 - 500.00mH [Depend on HD30]
		90kW and above motor	0.000 - 50.000 mH [Depend on HD30]
F13.12	Idling exciting current of motor 2	5.5kW and below motor	0.0 - 999.9A [Depend on HD30]
		5.5kW above motor	0.00 - 99.99A [Depend on HD30]
F13.13	Motor 2 core saturation coefficient 1	0.00 - 1.00 [1.00]	
F13.14	Motor 2 core saturation coefficient 2	0.00 - 1.00 [1.00]	
F13.15	Motor 2 core saturation coefficient 3	0.00 - 1.00 [1.00]	

Ref. Code	Function Description	Setting Range [Default]
F13.16	V/f curve selection of motor 2 0: Line. 1: Square curve. 2: 1.2 exponential curve. 3: 1.7 exponential curve. 4: User-defined curve.	0 - 4 [0]
F13.17	V/f frequency value F3 of motor 2	F13.19 - 100.0 [0.0%]
F13.18	V/f voltage value V3 of motor 2	F13.20 - 100.0 [0.0%]
F13.19	V/f frequency value F2 of motor 2	F13.21 - F13.17 [0.0%]
F13.20	V/f voltage value V2 of motor 2	F13.22 - F13.18 [0.0%]
F13.21	V/f frequency value F1 of motor 2	0.0 - F13.19 [0.0%]
F13.22	V/f voltage value V1 of motor 2	0.0 - F13.20 [0.0%]
F13.23	Torque boost of motor 2	0.0 - 30.0 [45kW and below inverter: 2.0%] [55 - 132kW inverter: 1.0%] [160kW and above inverter: 0.5%]
F13.24	Cut-off point used for manual torque boost of motor 2	0.0 - 50.0 (F13.04) [25%]
F13.25	Slip compensation gain of motor 2	0.0 - 300.0 [0.0%]
F13.26	Slip compensation filter time of motor 2	0.01 - 10.00 [0.10s]
F13.27	Slip compensation limitation of motor 2	0.0 - 250.0 [200.0%]
F13.28	Compensation constant of motor 2	0.000 - 9.999kW [Depend on HD30]
F13.30	AVR (automatic voltage regulation) function of motor 2 0: Disabled. 1: Enabled all the time. 2: Disabled in Dec. process.	0 - 2 [1]
F13.31	Motor 2 low frequency suppression shock coefficient	0 - 200 [50]
F13.32	Motor 2 high frequency suppression shock coefficient	0 - 200 [20]
F13.33	Motor 2 energy saving control select 0: Energy saving control invalid. 3: Energy saving according to output current.	0 - 3 [0]
F13.34	Motor 2 energy saving factor	0.0 - 100.0 [5.0%]
F13.35	Speed control proportional gain 1 of motor 2	0.1 - 200.0 [10.0]
F13.36	Speed control integral time 1 of motor 2	0.00 - 10.00 [0.20s]
F13.37	Speed control proportional gain 2 of motor 2	0.1 - 200.0 [10.0]
F13.38	Speed control integral time 2 of motor 2	0.00 - 10.00 [0.20s]
F13.39	Speed-loop PI switching frequency 1 of motor 2	0.00 - F13.40 [10.00Hz]
F13.40	Speed-loop PI switching frequency 2 of motor 2	F13.39 - 50.00 [15.00Hz]
F13.41	Speed-loop integral limitation of motor 2	0.0 - 200.0 (F13.03) [180.0%]
F13.42	Speed-loop differential time of motor 2	0.00 - 1.00 [0.00s]
F13.43	Speed-loop output filter time of motor 2	0.000 - 1.000 [0.000s]
F13.44	Motor 2 torque limit lock selection 0: Do not lock. 1: All of the torque limit is same with FWD electric torque limit.	0,1 [0]

Ref. Code	Function Description	Setting Range [Default]
F13.45	Motor 2 Torque limit channel Unit: Forward rotation electric torque limit channel Ten: Reverse electric torque limit channel Hundred: Forward rotation torque limit channel Thousand: Reverse rotation torque limit channel <ul style="list-style-type: none"> • 0: Number limit. • 1: Analog input limit. • 2: Terminal pulse limit. • 3 - 6: AI1 - AI4 limit. • 7: Keypad potentiometer is limited. 	0000 - 7777 [0000]
F13.46	Motor torque limitation when motor 2 is forward	0.0 - 200.0 (F13.03) [180.0%]
F13.47	Motor torque limitation when motor 2 is reverse	
F13.48	Recreated torque limitation when motor 2 is forward	
F13.49	Recreated torque limitation when motor 2 is reverse	
F13.50	Motor 2 current loop KP	
F13.51	Motor 2 current loop Ki	1 - 2000 [400]
F13.52	Motor 2 current loop output filter times	1 - 1000 [200]
F13.53	Motor 2 core saturation coefficient 4	0 - 31 [3]
F13.54	Motor 2 core saturation coefficient 5	0.00 - 1.00 [1.00]
F13.55	Motor 2 current loop feedforward enabled 0: Feedforward is prohibited. 1: Enable feedforward.	0,1 [1]
F13.56	Motor 2 excitation boost setting	0.0 - 30.0 [0.0%]
F13.57	Motor 2 field orientation optimization setting Unit: Field orientation angle correction enable <ul style="list-style-type: none"> • 0: Field orientation correction is forbidden. • 1: Enables magnetic field orientation correction. Ten: Mutual inductance projections enabled <ul style="list-style-type: none"> • 0: Disable mutual inductance based on flux calculation. • 1: Enable mutual inductance based on flux calculation. 	00 - 11 [00]
F13.58	Motor 2 energy start frequency	0.00 - 50.00 [25.00Hz]
F13.59	Motor 2 energy switching point	0.0 - 100.0 [100.0%]
F13.60	Motor 2 energy saving detecting times	0 - 5000 [10 times]
F13.61	Motor 2 energy voltage recovery time	40 - 4000 [100ms]
F13.62	Motor 2 energy voltage decreasing time	40 - 4000 [100ms]

6.2.14 F15: Digital I/O Terminal Parameters

Ref. Code	Function Description	Setting Range [Default]
F15.00	D11 function	0 - 87 [2]
F15.01	D12 function	0 - 87 [3]
F15.02	D13 function	0 - 87 [0]
F15.03	D14 function	0 - 87 [0]
F15.04	D15 function	0 - 87 [0]
F15.05	D16 function	0 - 87 [0]
F15.06	D17 function	0 - 87 [0]
F15.07	D18 function	0 - 87 [0]
F15.08	D19 function	0 - 87 [0]

Note: Only when using HD30-EIO will F15.06 - F15.08 be enabled.

0: Unused. It disables the terminal's function. The inverter ignores the signal input via this terminal.

- The unwanted terminal is recommended to be set as 0 so as to avoid wrong connection or action.

1: Inverter enabled.

- When enabled, the inverter is enabled to run.
- When disabled, the inverter is disabled to run and will be in auto stop status.
- If no terminal selects this function, it defaults that the inverter is enabled.

2,3: FWD/REV function. You can set any multi-function terminal for the FWD/REV terminal to control the inverter's run and stop.

- The forward / reverse function is only active in the terminal control mode.
- Refer to parameter F15.16.

4: Three-wire operation mode.

- Refer to parameter F15.16.

5 - 7,87: Frequency source selection 1 - 4.

- Up to 2ⁿ frequency reference sources can be switched through terminal logic combination setting n (the max. n is 4). Refer to the below table.

Source 4 (No 87)	Source 3 (No 7)	Source 2 (No 6)	Source 1 (No 5)	Setting channel
0	0	0	0	Holding
0	0	0	1	Display panel digital setting
0	0	1	0	Terminal digital setting
0	0	1	1	SCI communication digital setting
0	1	0	0	Analogue value setting
0	1	0	1	Terminal pulse setting
0	1	1	X	Hold
1	0	0	0	Panel digital setting
1	0	0	1	Terminal digital setting
1	0	1	0	Communicaiton digital setting
1	0	1	1	A11 setting
1	1	0	0	A12 setting
1	1	0	1	A13 setting
1	1	1	0	A14 setting
1	1	1	1	Keypad potentiometer setting

Ref. Code	Function Description	Setting Range [Default]															
	<p>8: The frequency source switch to analogue setting.</p> <ul style="list-style-type: none"> If the setting is 8, the frequency reference source can be forcibly switched to analogue setting. The priority of frequency sources is shown below: Keypad M key Local remote switching function (F00.12 = 1) > frequency switch to analog (DI terminal is set to function No. 8) > switch to normal operation mode (DI terminal is set to function 30) > PLC > wobble > multi-frequency terminal setting channel (DI terminal is set to function 13 - 16) > frequency setting channel selection terminal 1 - 3 setting the channel (function of DI terminal is set to 5 - 7) > F00.10 set the frequency setting channel. <p>9,10: Run command source selection 1, 2.</p> <ul style="list-style-type: none"> In the below table there are 4 kind control modes selected by the different logic combinations of terminals 1 and 2. <table border="1" style="width: 100%; border-collapse: collapse;"> <thead> <tr> <th style="width: 33%;">Command source 2 (No 10)</th> <th style="width: 33%;">Command source 1 (No 9)</th> <th style="width: 33%;">Selection</th> </tr> </thead> <tbody> <tr> <td style="text-align: center;">0</td> <td style="text-align: center;">0</td> <td>Hold the control mode</td> </tr> <tr> <td style="text-align: center;">0</td> <td style="text-align: center;">1</td> <td>Display panel control mode</td> </tr> <tr> <td style="text-align: center;">1</td> <td style="text-align: center;">0</td> <td>Terminal control mode</td> </tr> <tr> <td style="text-align: center;">1</td> <td style="text-align: center;">1</td> <td>SCI communication control mode</td> </tr> </tbody> </table> <ul style="list-style-type: none"> The inverter can accept that run command source switch changes while running, but only at stop status all switches can be enabled. <p>11: Switch to terminal control mode.</p> <ul style="list-style-type: none"> When this terminal function is enabled, the run command source will be forcibly switched to the terminal control mode. The priority of frequency selection is below: Keypad M key Local remote switching function (F00.12 = 1) > command switched to terminal (DI terminal is set to function 11) > command channel for terminal 1, 2 (DI terminal is set to 9,10 function) is selected as run command channel > running command channel set in F00.11. <p>12: External stop command input.</p> <ul style="list-style-type: none"> When enabled, the inverter stops according to F02.13 (stop mode selection). It is valid for all command source. 	Command source 2 (No 10)	Command source 1 (No 9)	Selection	0	0	Hold the control mode	0	1	Display panel control mode	1	0	Terminal control mode	1	1	SCI communication control mode	
Command source 2 (No 10)	Command source 1 (No 9)	Selection															
0	0	Hold the control mode															
0	1	Display panel control mode															
1	0	Terminal control mode															
1	1	SCI communication control mode															

Ref. Code	Function Description	Setting Range [Default]																																																																																					
	<p>13 - 16: Multi-step frequency terminal 1 - 4.</p> <ul style="list-style-type: none"> Up to 15 speed references can be set through different logic combinations of terminals. The inverter can realise 15-step speed operation through the logical combinations of 4 terminals. The inverter can realise 7-step speed operation through the logical combinations of 3 terminals. The inverter can realise 3-step speed operation through the logical combinations of 2 terminals. The inverter can realise the switch between setting frequency and multi-step frequency through one terminal function. Refer to the below table and figure. K1 is corresponding to terminal 1, K2 is corresponding to terminal 2, K3 is corresponding to terminal 3 and K4 is corresponding to terminal 4. <table border="1" style="width: 100%; border-collapse: collapse;"> <thead> <tr> <th>K4 (No 16)</th> <th>K3 (No 15)</th> <th>K2 (No 14)</th> <th>K1 (No 13)</th> <th>Frequency setting</th> </tr> </thead> <tbody> <tr><td>0</td><td>0</td><td>0</td><td>0</td><td>Setting frequency</td></tr> <tr><td>0</td><td>0</td><td>0</td><td>1</td><td>Multi-step frequency 1 (F06.00)</td></tr> <tr><td>0</td><td>0</td><td>1</td><td>0</td><td>Multi-step frequency 2 (F06.01)</td></tr> <tr><td>0</td><td>0</td><td>1</td><td>1</td><td>Multi-step frequency 3 (F06.02)</td></tr> <tr><td>0</td><td>1</td><td>0</td><td>0</td><td>Multi-step frequency 4 (F06.03)</td></tr> <tr><td>0</td><td>1</td><td>0</td><td>1</td><td>Multi-step frequency 5 (F06.04)</td></tr> <tr><td>0</td><td>1</td><td>1</td><td>0</td><td>Multi-step frequency 6 (F06.05)</td></tr> <tr><td>0</td><td>1</td><td>1</td><td>1</td><td>Multi-step frequency 7 (F06.06)</td></tr> <tr><td>1</td><td>0</td><td>0</td><td>0</td><td>Multi-step frequency 8 (F06.07)</td></tr> <tr><td>1</td><td>0</td><td>0</td><td>1</td><td>Multi-step frequency 9 (F06.08)</td></tr> <tr><td>1</td><td>0</td><td>1</td><td>0</td><td>Multi-step frequency 10 (F06.09)</td></tr> <tr><td>1</td><td>0</td><td>1</td><td>1</td><td>Multi-step frequency 11 (F06.10)</td></tr> <tr><td>1</td><td>1</td><td>0</td><td>0</td><td>Multi-step frequency 12 (F06.11)</td></tr> <tr><td>1</td><td>1</td><td>0</td><td>1</td><td>Multi-step frequency 13 (F06.12)</td></tr> <tr><td>1</td><td>1</td><td>1</td><td>0</td><td>Multi-step frequency 14 (F06.13)</td></tr> <tr><td>1</td><td>1</td><td>1</td><td>1</td><td>Multi-step frequency 15 (F06.14)</td></tr> </tbody> </table>	K4 (No 16)	K3 (No 15)	K2 (No 14)	K1 (No 13)	Frequency setting	0	0	0	0	Setting frequency	0	0	0	1	Multi-step frequency 1 (F06.00)	0	0	1	0	Multi-step frequency 2 (F06.01)	0	0	1	1	Multi-step frequency 3 (F06.02)	0	1	0	0	Multi-step frequency 4 (F06.03)	0	1	0	1	Multi-step frequency 5 (F06.04)	0	1	1	0	Multi-step frequency 6 (F06.05)	0	1	1	1	Multi-step frequency 7 (F06.06)	1	0	0	0	Multi-step frequency 8 (F06.07)	1	0	0	1	Multi-step frequency 9 (F06.08)	1	0	1	0	Multi-step frequency 10 (F06.09)	1	0	1	1	Multi-step frequency 11 (F06.10)	1	1	0	0	Multi-step frequency 12 (F06.11)	1	1	0	1	Multi-step frequency 13 (F06.12)	1	1	1	0	Multi-step frequency 14 (F06.13)	1	1	1	1	Multi-step frequency 15 (F06.14)	
K4 (No 16)	K3 (No 15)	K2 (No 14)	K1 (No 13)	Frequency setting																																																																																			
0	0	0	0	Setting frequency																																																																																			
0	0	0	1	Multi-step frequency 1 (F06.00)																																																																																			
0	0	1	0	Multi-step frequency 2 (F06.01)																																																																																			
0	0	1	1	Multi-step frequency 3 (F06.02)																																																																																			
0	1	0	0	Multi-step frequency 4 (F06.03)																																																																																			
0	1	0	1	Multi-step frequency 5 (F06.04)																																																																																			
0	1	1	0	Multi-step frequency 6 (F06.05)																																																																																			
0	1	1	1	Multi-step frequency 7 (F06.06)																																																																																			
1	0	0	0	Multi-step frequency 8 (F06.07)																																																																																			
1	0	0	1	Multi-step frequency 9 (F06.08)																																																																																			
1	0	1	0	Multi-step frequency 10 (F06.09)																																																																																			
1	0	1	1	Multi-step frequency 11 (F06.10)																																																																																			
1	1	0	0	Multi-step frequency 12 (F06.11)																																																																																			
1	1	0	1	Multi-step frequency 13 (F06.12)																																																																																			
1	1	1	0	Multi-step frequency 14 (F06.13)																																																																																			
1	1	1	1	Multi-step frequency 15 (F06.14)																																																																																			
	<p>17,18: Frequency ramp (UP) / (DN).</p> <ul style="list-style-type: none"> If the setting is 17 or 18, the terminal can be used to increase or decrease frequency, and accordingly enables remote control. Increase or decrease rate is determined by F15.12. The function refers to below table. This terminal is enabled when F00.10 = 1 (terminal digital setting) or F19.00 = 2 (terminal digital setting). <table border="1" style="width: 100%; border-collapse: collapse;"> <thead> <tr> <th>UP command (No 17)</th> <th>DN command (No 18)</th> <th>Frequency change trend</th> </tr> </thead> <tbody> <tr><td>0</td><td>0</td><td>To keep the setting frequency</td></tr> <tr><td>0</td><td>1</td><td>To decrease the setting frequency</td></tr> <tr><td>1</td><td>0</td><td>To increase the setting frequency</td></tr> <tr><td>1</td><td>1</td><td>To keep the setting frequency</td></tr> </tbody> </table>	UP command (No 17)	DN command (No 18)	Frequency change trend	0	0	To keep the setting frequency	0	1	To decrease the setting frequency	1	0	To increase the setting frequency	1	1	To keep the setting frequency																																																																							
UP command (No 17)	DN command (No 18)	Frequency change trend																																																																																					
0	0	To keep the setting frequency																																																																																					
0	1	To decrease the setting frequency																																																																																					
1	0	To increase the setting frequency																																																																																					
1	1	To keep the setting frequency																																																																																					
	<p>19: Clearing auxiliary frequency setting.</p> <ul style="list-style-type: none"> When the setting is 19, this terminal is used to clear the counter to zero, but it is only valid for digital auxiliary setting. 																																																																																						
	<p>20,21: Command control input for forward and reverse jog 1 (JOGF1/ JOGR1).</p>																																																																																						
	<p>22,23: Command control input for forward and reverse jog 2 (JOGF2/ JOGR2).</p>																																																																																						

Ref. Code	Function Description	Setting Range [Default]																														
	<p>24,25: Jog 1 command and direction control input.</p> <ul style="list-style-type: none"> In terminal control mode, if 24 or 25 are enabled, then forward jog or reverse jog operation are enabled. JOGF is forward jog command and JOGR is reverse jog command. It need define parameters F00.15 (jog frequency), F00.16 (jog interval), F03.15 (Acc. time of jog operation) and F03.16 (Dec. time of jog operation), referring to below table. <table border="1" style="width: 100%; border-collapse: collapse; text-align: center;"> <thead> <tr> <th style="width: 33%;">Jog direction input (No. 25)</th> <th style="width: 33%;">Jog command input (No. 24)</th> <th style="width: 34%;">Run command</th> </tr> </thead> <tbody> <tr> <td>0</td> <td>0</td> <td>Jog command is invalid</td> </tr> <tr> <td>1</td> <td>0</td> <td>Jog command is invalid</td> </tr> <tr> <td>0</td> <td>1</td> <td>Jog 1 forward</td> </tr> <tr> <td>1</td> <td>1</td> <td>Jog 1 reverse</td> </tr> </tbody> </table> <p><i>Note: When select 20 and 21, the functions 24 and 25 are invalid.</i></p> <p>26,27: Acc. / Dec. time selection terminals 1 and 2.</p> <ul style="list-style-type: none"> Acc. / Dec. time 1 - 4 can be selected through logic combination of the terminals 1 and 2. The inverter can realise 4 Groups Acc. / Dec. time selection through the function of 2 Acc. / Dec. terminals. The inverter can realise 2 Groups Acc. / Dec. time selection through the function of 1 Acc. / Dec. terminals. <table border="1" style="width: 100%; border-collapse: collapse; text-align: center;"> <thead> <tr> <th style="width: 33%;">Acc. / Dec. terminal 2 (No 27)</th> <th style="width: 33%;">Acc. / Dec. terminal 1(No 26)</th> <th style="width: 34%;">Acc. / Dec. selection</th> </tr> </thead> <tbody> <tr> <td>0</td> <td>0</td> <td>Acc. / Dec. time 1</td> </tr> <tr> <td>0</td> <td>1</td> <td>Acc. / Dec. time 2</td> </tr> <tr> <td>1</td> <td>0</td> <td>Acc. / Dec. time 3</td> </tr> <tr> <td>1</td> <td>1</td> <td>Acc. / Dec. time 4</td> </tr> </tbody> </table> <p>28: Acc. / Dec. mode selection.</p> <ul style="list-style-type: none"> If the setting is enabled, the S-curve Acc. / Dec. mode will be selected. While the setting is disabled, linear Acc. / Dec. mode will be selected. The Acc. / Dec. mode set by terminal No. 28 function is priority to by F03.00. <p>29: Acc. / Dec. prohibition.</p> <ul style="list-style-type: none"> If the setting is 29, this terminal can make the motor immune to external signals (except stop command) and maintain operation at the current speed. The function is disabled in the process of Dec. to stop. <p>30: Switch to ordinary running mode.</p> <ul style="list-style-type: none"> When this function is enabled, the frequency command (including MS function, simple PLC function, process PID function, wobble function etc.) forced to switch to the ordinary mode operation. <p>31: Reset the stop status of PLC operation.</p> <ul style="list-style-type: none"> In the stop status of PLC operation, the memorized PLC operating information (operating step, operating time, operating frequency, etc.) will be cleared when this terminal is enabled, referring to Group F06. <p>32: Pausing the process PID.</p> <ul style="list-style-type: none"> If the setting is 32, the process PID function is temporary disabled and the inverter keeps the present frequency output and continue running. <p>33: Disabling the process PID.</p> <ul style="list-style-type: none"> To achieve the flexible switch between the process PID and the lower class operation mode. When enabled, the operation mode switches to the lower class. The priority of operation mode is as: Jog operation > process PID operation > PLC operation > wobble operation > MS speed operation > operation. 	Jog direction input (No. 25)	Jog command input (No. 24)	Run command	0	0	Jog command is invalid	1	0	Jog command is invalid	0	1	Jog 1 forward	1	1	Jog 1 reverse	Acc. / Dec. terminal 2 (No 27)	Acc. / Dec. terminal 1(No 26)	Acc. / Dec. selection	0	0	Acc. / Dec. time 1	0	1	Acc. / Dec. time 2	1	0	Acc. / Dec. time 3	1	1	Acc. / Dec. time 4	
Jog direction input (No. 25)	Jog command input (No. 24)	Run command																														
0	0	Jog command is invalid																														
1	0	Jog command is invalid																														
0	1	Jog 1 forward																														
1	1	Jog 1 reverse																														
Acc. / Dec. terminal 2 (No 27)	Acc. / Dec. terminal 1(No 26)	Acc. / Dec. selection																														
0	0	Acc. / Dec. time 1																														
0	1	Acc. / Dec. time 2																														
1	0	Acc. / Dec. time 3																														
1	1	Acc. / Dec. time 4																														

Ref. Code	Function Description	Setting Range [Default]
	<p>34: Holding PID integral.</p> <ul style="list-style-type: none"> When enabled, the process PID stops increasing and the integrator keeps the present result. <p>35: Clearing PID integral.</p> <ul style="list-style-type: none"> When enabled, the process PID is cleared. <p>36: Switch to wobble operation.</p> <ul style="list-style-type: none"> The wobble operation mode selects manual start (set the units of F07.01 to 1). If the setting is 36, the wobble function is enabled. <p>37: Reset the wobble operating status.</p> <ul style="list-style-type: none"> If wobble operation (set F07.00 to 1) is enabled, connecting this terminal can clear all the memorised information about the wobble operation no matter the inverter is in auto start or manual start mode (depend on F07.01 setting). <p>38: DC braking start while stopping.</p> <ul style="list-style-type: none"> To implement DC braking for the motor in stop status through control terminal and then realise motor's emergency stop and accuracy location. F02.04 defines the DC braking current. When the terminal is active during deceleration and stop, the motor is braked immediately. When invalid, stop DC braking. <p>39,40: External pause signal (normally-open/normally-closed input).</p> <ul style="list-style-type: none"> After receiving an external pause command during the running process, the inverter will immediately stop. Once the external signal is removed and the situation meets the running condition, the inverter will start tracking at high speed. <p>41,42: Coast to stop (normally-open/normally-closed input).</p> <ul style="list-style-type: none"> The inverter will stop outputting immediately and the load will coast to stop in accordance with the mechanical inertia when a multi-function terminal is set as 41 or 42. <p>43: Emergency stop.</p> <ul style="list-style-type: none"> After receiving terminal command, the inverter will decelerate to stop during the Dec. time according to the F03.17 (Dec. time of emergency stop). <p>44,45: External fault signal (normally-open and normally-closed input).</p> <ul style="list-style-type: none"> If the setting is 44 or 45, the fault signal of external equipment can be input via the terminal, which is convenient for the inverter to monitor the external equipment and carry out protection according to the value of F15.17. Once the inverter receives the fault signal, it will display external fault. The fault signal has two input modes: normally-open and normally-closed input. <p>46: External reset (RST) input.</p> <ul style="list-style-type: none"> If the setting is 46, the inverter can be reset via this terminal when it has a fault. Accordingly the terminal has the same function as the STOP key on the keypad. <p>47: Switch between motor 1 and motor 2.</p> <ul style="list-style-type: none"> When enabled, it can realise parameters of the two motors to switch. <p>48: Timing function input. If the setting is 48, the inverter can use the timing function input terminal.</p> <ul style="list-style-type: none"> Refer to parameters F15.25 and F15.26. <p>49: Clearing the length.</p> <ul style="list-style-type: none"> If the setting is 49, the inverter can use clearing the length input terminal in the fixed length control. Refer to parameters F19.26 - F19.34. <p>50: Clearing the counter to zero. When the setting is 50, this terminal is used to clear the counter to zero.</p> <ul style="list-style-type: none"> It is normally used with Function 51 (counter's triggering signal input). 	

Ref. Code	Function Description	Setting Range [Default]																																				
	<p>51: Counter's triggering signal input.</p> <ul style="list-style-type: none"> It is built-in counter's counting pulse input port and can save the current counting value at power loss. Pulse's max. frequency: 200Hz. Refer to parameters F15.37 and F15.38. <p>52: Length counting input.</p> <ul style="list-style-type: none"> If the setting is 52, it can be used as length input terminal in the fixed length control. Refer to parameters F19.26 - F19.34. <p>53: Pulse frequency input (only DI6 terminal is enabled).</p> <ul style="list-style-type: none"> This terminal is used to input pulse signal as frequency setting. See Group F05 parameters for the relationship between input pulse frequency and frequency setting. <p>54: Main and auxiliary frequency source switching.</p> <p>56: Speed control / torque control switching.</p> <ul style="list-style-type: none"> When active: F00.00 = 0 is switched from speed control to torque control; F00.00 = 1 is switched from torque control to speed control. Invalid: Determines speed control or torque control according to F00.00 (control mode selection). <p>57: Torque control torque polarity switching.</p> <ul style="list-style-type: none"> When valid: The torque reference polarity determined by the F21 Group parameter is reversed. Invalid: Keep the torque reference polarity determined by the F21 Group parameter. <p>59: PID parameter switch.</p> <p>85: Pausing PLC operation.</p> <ul style="list-style-type: none"> If the setting is 85, this terminal is used to pause the PLC operation. The inverter will operate at the frequency of the current step when the terminal is enabled, and there is no timing at PLC operation. When disabled, the timing will continue. <p>86: Terminal stop DC braking.</p> <ul style="list-style-type: none"> When the inverter is in operation or during shutdown, the inverter will be DC braked immediately after terminals valid. If there is no stop command, the inverter will restart. <p>87: Frequency setting channel selection 4.</p> <ul style="list-style-type: none"> See function 5 - 7 instructions. 																																					
F15.12	Acc. / Dec. rate of UP/DN terminal It defines the change rate of setting frequency via the UP/DN terminal.	0.00 - 99.99 [1.00 Hz/s]																																				
F15.13	Terminal detecting interval 0: 2ms. 1: 4ms. 2: 8ms.	0 - 2[0]																																				
F15.14	Terminal detecting filter number The digital input terminal signal should be delayed and confirmed so as to avoid digital input error.	0 - 10000 [2]																																				
F15.15	Terminal input positive and negative logic setting It defines that each bit (binary) of this function represents different physical sources. <ul style="list-style-type: none"> 0: Positive logic: When DI terminals are connected to corresponding common port, this logic is enabled. Otherwise the logic is disabled. 1: Negative logic: When DI terminals are connected to corresponding common port, this logic is disabled. Otherwise the logic is enabled. <table border="1" style="margin-left: 20px;"> <thead> <tr> <th colspan="4">Hundred</th> <th colspan="4">Ten</th> <th colspan="4">Unit</th> </tr> <tr> <th>Bit11</th> <th>Bit10</th> <th>Bit9</th> <th>Bit8</th> <th>Bit7</th> <th>Bit6</th> <th>Bit5</th> <th>Bit4</th> <th>Bit3</th> <th>Bit2</th> <th>Bit1</th> <th>Bit0</th> </tr> </thead> <tbody> <tr> <td>-</td> <td>-</td> <td>-</td> <td>DI9</td> <td>DI8</td> <td>DI7</td> <td>DI6</td> <td>DI5</td> <td>DI4</td> <td>DI3</td> <td>DI2</td> <td>DI1</td> </tr> </tbody> </table>	Hundred				Ten				Unit				Bit11	Bit10	Bit9	Bit8	Bit7	Bit6	Bit5	Bit4	Bit3	Bit2	Bit1	Bit0	-	-	-	DI9	DI8	DI7	DI6	DI5	DI4	DI3	DI2	DI1	000 - 0x1FF [000]
Hundred				Ten				Unit																														
Bit11	Bit10	Bit9	Bit8	Bit7	Bit6	Bit5	Bit4	Bit3	Bit2	Bit1	Bit0																											
-	-	-	DI9	DI8	DI7	DI6	DI5	DI4	DI3	DI2	DI1																											
<p>Note: Only when using HD30-EIO will DI7 - DI9 be enabled.</p>																																						

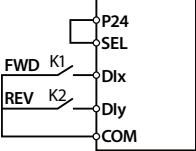
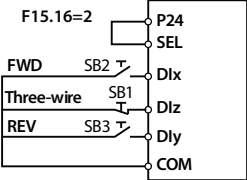
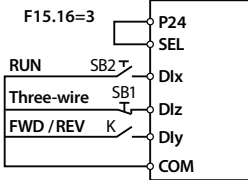
Ref. Code	Function Description	Setting Range [Default]																					
F15.16	FWD/REV operation mode	0 - 3 [0]																					
	<p>This function defines the four control modes via the external terminals.</p> <ul style="list-style-type: none"> FWD can be selected by DI terminal Dlx and represented as "FWD". At this time, the function of this terminal should be defined as No. 2 function. REV can be selected by DI terminal Dly and represented as "REV". At this time, the function of this terminal should be defined as No. 3 function. <p>0: Two-wire operation mode 1. 1: Two-wire operation mode 2.</p> <ul style="list-style-type: none"> When stop command coming from other sources (or PLC single cycle stop, fixed length stop, terminal external stop instruction input valid, terminal free stop instruction input valid, inverter failure / external fault effective) makes the inverter stopping though the terminal logic enabled in the terminal control mode, there is no run command even the control terminal FWD/REV are still valid. If you want the inverter to run again, you should trigger the active FWD and REV.  <table border="1" data-bbox="571 515 837 674"> <thead> <tr> <th rowspan="2">K2</th> <th rowspan="2">K1</th> <th colspan="2">Run Command</th> </tr> <tr> <th>F15.16=0</th> <th>F15.16=1</th> </tr> </thead> <tbody> <tr> <td>0</td> <td>0</td> <td>Stop</td> <td>Stop</td> </tr> <tr> <td>1</td> <td>0</td> <td>Reverse</td> <td>Stop</td> </tr> <tr> <td>0</td> <td>1</td> <td>Forward</td> <td>Forward</td> </tr> <tr> <td>1</td> <td>1</td> <td>Stop</td> <td>Reverse</td> </tr> </tbody> </table> <p>2: Three-wire operation mode 1.</p> <ul style="list-style-type: none"> If the shift between SB2 and SB3 is disabled, the inverter will hold the control mode. <p>3: Three-wire operation mode 2.</p> <ul style="list-style-type: none"> If SB2 changes from enabled into disabled, the inverter will keep the same mode. Dli can be selected by the DI terminal Dlz. At this time, the function of this terminal should be defined as No. 4 function of "three-wire operation".   <p><i>SB1: Normally closed stop button SB2: Normally open forward button SB3: Normally open reverse button</i></p> <p><i>K: Direction selection terminal (level on) K = 0(forward) K = 1(reverse) SB1: Normally closed stop button SB2: Normally open run button</i></p>	K2	K1	Run Command		F15.16=0	F15.16=1	0	0	Stop	Stop	1	0	Reverse	Stop	0	1	Forward	Forward	1	1	Stop	Reverse
K2	K1			Run Command																			
		F15.16=0	F15.16=1																				
0	0	Stop	Stop																				
1	0	Reverse	Stop																				
0	1	Forward	Forward																				
1	1	Stop	Reverse																				
F15.17	Terminal operating selection due to fault of external equipment	0 - 3 [0]																					
	<p>When there is fault of external equipment, it can select protection.</p> <p>0: Coast to stop. 1: Emergency stop. 2: Dec. to stop. 3: Continue to run.</p>																						
F15.18	DO1 function	0 - 36 [2]																					
F15.19	DO2 function	0 - 38 [0]																					
F15.20	RLY1 function	0 - 36 [31]																					
F15.21	RLY2 function	0 - 36 [0]																					
F15.22	RLY3 function	0 - 36 [0]																					

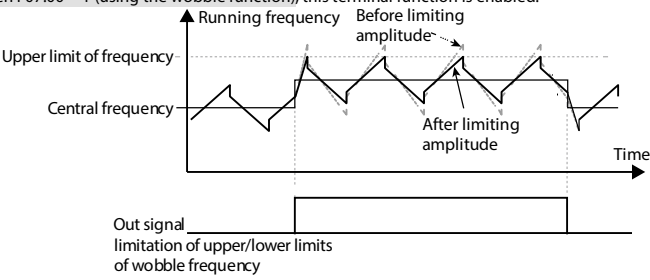
Ref. Code	Function Description	Setting Range [Default]
F15.23	<p>RLY4 function</p> <p><i>Note: Only when using HD30-EIO will F15.21 - F15.23 be enabled.</i></p> <p>0: Unused. There is no output function and action of the output terminal.</p> <p>1: Inverter ready.</p> <ul style="list-style-type: none"> The inverter completes power on and no fault occurs, then it can normally run the indicating signal. <p>2: Inverter is running.</p> <ul style="list-style-type: none"> The inverter is in run status and output indicating signal. <p>3: Inverter is forward running.</p> <ul style="list-style-type: none"> The inverter is forward running the indicating signal. <p>4: Inverter is reverse running.</p> <ul style="list-style-type: none"> The inverter is reverse running the indicating signal. <p>5: Inverter is DC braking.</p> <ul style="list-style-type: none"> The inverter is DC braking the indicating signal. <p>6: Inverter is in zero-frequency status.</p> <ul style="list-style-type: none"> In the zero-frequency range the inverter's output frequency (including in stop status) outputs the indication signal. Refer to parameters F15.28 and F15.29. <p>7: Inverter is in zero-frequency running.</p> <ul style="list-style-type: none"> In the zero-frequency range the inverter's output frequency outputs the indicating signal. Refer to parameters F15.28 and F15.29. <p>9,10: Frequency detection threshold (FDT1, FDT2).</p> <ul style="list-style-type: none"> Refer to F15.31 - F15.35. <p>11: Frequency arriving signal (FAR).</p> <ul style="list-style-type: none"> Indication signal will be output when the inverter's output frequency is within the FAR range. The FAR is set by F15.27 (FAR range). <p>12: Limitation of upper limit of frequency.</p> <ul style="list-style-type: none"> The indicating signal will be output if the setting frequency is beyond the upper limit of frequency. <p>13: Limitation of lower limit of frequency.</p> <ul style="list-style-type: none"> The indicating signal will be output if the setting frequency is lower than the lower limit of frequency. <p>14: Limitation of upper/lower limits of wobble frequency.</p> <ul style="list-style-type: none"> If the wobble frequency calculated by the central frequency is higher than upper limit of frequency or lower than the lower limit of frequency (F00.09), signal will be output, as shown in figure. When F07.00 = 1 (using the wobble function), this terminal function is enabled.  <p>15: Simple PLC operating status indication.</p> <ul style="list-style-type: none"> The indicating signal will be output when the inverter is at simple PLC operating. <p>16: Simple PLC pausing indication.</p> <ul style="list-style-type: none"> The indicating signal will be output if the simple PLC operation is suspended by external terminals. 	0 - 36 [0]

Ref. Code	Function Description	Setting Range [Default]
	<p>17: Simple PLC cycle completion indication.</p> <ul style="list-style-type: none"> The indicating signal will be output if one cycle of PLC operation is finished. <p>18: Completion of simple PLC operation stages.</p> <ul style="list-style-type: none"> The indicating signal will be output if the current step of PLC operation is finished. <p>19: Completion of simple PLC operation.</p> <ul style="list-style-type: none"> The indicating signal will be output if the PLC operation is finished. <p>20: Output data from SCI communication.</p> <ul style="list-style-type: none"> Output indicating signal of open collector or relay is controlled by the SCI communication directly. <p>21: Preset operating time out.</p> <ul style="list-style-type: none"> The indicating signal will be output if the inverter's operating time reaches the preset operating time (F15.36). <p><i>Note: The No. 17, 18, 19 and 21 functions output indicating signal which is single pulse signal, 500ms.</i></p> <p>22: Timing function output.</p> <ul style="list-style-type: none"> If the setting is 22, the inverter can use the timing function output terminal. Refer to parameters F15.25 and F15.26. <p>23: Preset counting value reach.</p> <p>24: Indicating counting value reach.</p> <ul style="list-style-type: none"> Refer to F15.37 and F15.38. <p>25: Setting length arrive.</p> <ul style="list-style-type: none"> The indicating signal will be output if the inverter's actual length reaches the preset length. <p>26: Indication of motor 1 and motor 2.</p> <ul style="list-style-type: none"> According to the current motor selection, output corresponding indicating signal. When the inverter controls the motor 1, this signal will be disabled; while controls the motor 2, it will output the indicating signal. <p>27: Analog input overrun output.</p> <ul style="list-style-type: none"> When the analog value exceeds the upper or lower limit, the indicator is output. Refer to F15.39 - F15.42. <p>29: Undervoltage lock-up signal (LU).</p> <ul style="list-style-type: none"> When the DC bus voltage is lower than the undervoltage threshold, the inverter will output undervoltage signal. The LED on the keypad will display “-Lu-”. <p>30: Overload signal (OL).</p> <ul style="list-style-type: none"> The indicating signal can be output when the inverter's output current value is higher than that defined by F20.01 (overload pre-alarm detection threshold) and the overload time is longer than that defined by F20.02 (overload pre-alarm detection time). <p>31: Inverter fault.</p> <ul style="list-style-type: none"> The inverter will output fault signal when it has a fault. <p>32: External fault.</p> <ul style="list-style-type: none"> The indicating signal can be output when the inverter detects the external fault signal via terminal. <p>33: Inverter auto-reset fault.</p> <ul style="list-style-type: none"> The indicating signal can be output when the inverter is during fault auto-reset. <p>35: Dormancy instruction function.</p> <p>36: The system is running.</p> <ul style="list-style-type: none"> The indicator is output when the drive is in operation or during sleep or when the analog override is waiting for restart. <p>38: High-frequency output (only DO2).</p> <ul style="list-style-type: none"> DO2 can be selected as high-frequency output. Refer to F16.21. 	

Ref. Code	Function Description	Setting Range [Default]																								
F15.24	<p>Output terminal positive and negative logic selection</p> <p>It defines that each bit (binary) of this function represents different physical sources.</p> <ul style="list-style-type: none"> • 0: Positive logic: When output terminals are connected to corresponding common port, this logic is enabled. Otherwise the logic is disabled. • 1: Negative logic: When output terminals are connected to corresponding common port, this logic is disabled. Otherwise the logic is enabled. <table border="1" style="width: 100%; text-align: center;"> <thead> <tr> <th colspan="4">Ten</th> <th colspan="4">Unit</th> </tr> <tr> <th>Bit7</th> <th>Bit6</th> <th>Bit5</th> <th>Bit4</th> <th>Bit3</th> <th>Bit2</th> <th>Bit1</th> <th>Bit0</th> </tr> </thead> <tbody> <tr> <td>-</td> <td>-</td> <td>RLY4</td> <td>RLY3</td> <td>RLY2</td> <td>RLY1</td> <td>DO2</td> <td>DO1</td> </tr> </tbody> </table> <p><i>Note: Only when using HD30-EIO will RLY2 - RLY4 be enabled.</i></p>	Ten				Unit				Bit7	Bit6	Bit5	Bit4	Bit3	Bit2	Bit1	Bit0	-	-	RLY4	RLY3	RLY2	RLY1	DO2	DO1	00 - 0x3F [00]
Ten				Unit																						
Bit7	Bit6	Bit5	Bit4	Bit3	Bit2	Bit1	Bit0																			
-	-	RLY4	RLY3	RLY2	RLY1	DO2	DO1																			
F15.25	ON side delay time of timing function	0.00 - 300.00 [0.00s]																								
F15.26	OFF side delay time of timing function																									
<p>F15.25 and F15.26 can be used to set the ON/OFF side delay time (dead area) of the timing function output relative to the input.</p> <ul style="list-style-type: none"> • The timing function output will be ON when the ON time of timing function is longer than that defined by F15.25. • The timing function output will be OFF when the OFF time of timing function delays behind that defined by F15.26. <p>The timing function operation figure is shown as follows:</p> <p>The diagram shows two waveforms: 'Timing function input' and 'Timing function output'. The input has several pulses. The output is delayed relative to the input. The delay from the start of an input pulse to the start of the output pulse is labeled F15.25. The delay from the end of an input pulse to the end of the output pulse is labeled F15.26. The output pulses are shaded gray and labeled 'ON'.</p>																										
F15.27	<p>FAR range</p> <p>The pulse signal will be output if the inverter's output frequency is within the FAR range. As shown in the right figure.</p>	0.00 - 100.00 [2.50Hz]																								
<p>The diagram shows a triangular wave representing 'Output' vs 'Time' with a peak labeled 'Preset frequency'. Two vertical dashed lines indicate a range, with the upper limit labeled F15.27 and the lower limit labeled F15.27. Below this, a square wave labeled 'DO-' vs 'Time' shows pulses that occur only when the frequency is within the range.</p>																										

Ref. Code	Function Description	Setting Range [Default]
F15.28	Zero-frequency operation threshold	0.00 - upper limit [0.00Hz]
F15.29	Zero-frequency hysteresis	
	<p>F15.28 and F15.29 are used to set the zero-frequency operation output control function, please see the right figure.</p>	
F15.30	FDT1 detection mode	0,1 [0]
	<p>0: Detect according to the reference frequency. 1: Detect according to the output frequency.</p>	
F15.31	FDT1 level	0.00 - upper limit [50.00Hz]
F15.32	FDT1 lag	0.00 - upper limit [1.00Hz]
	<p>The indicating signal can be output if the setting frequency F15.30 is higher than certain frequency (F15.31), and becomes disabled when the setting frequency is lower than certain frequency of FDT1 level (F15.31 - F15.32). Please refer to FL of the right figure.</p>	
F15.33	FDT2 detection mode	0,1 [0]
	<p>0: Detect according to the reference frequency. 1: Detect according to the output frequency.</p>	
F15.34	FDT2 level	0.00 - upper limit [50.00Hz]
F15.35	FDT2 lag	0.00 - upper limit [1.00Hz]
	Refer to parameters F15.31 and F15.32.	
F15.36	Preset operating time	0 - 65535 [0h]
	When the total operating time reaches the preset operating time (F15.36), the inverter will output an indicating signal (500ms).	

No.	Name Description	Range[factory setting]
F15.37	Preset counting value arriving	F15.38 - 9999 [0]
F15.38	Specified counting value arriving	0 - F15.37 [0]
	<p>F15.37 presents that when the number of pulse input by the DI terminals (set as No. 51 function) reaches a certain quantity, the DO terminals or relay will send an indicating signal.</p> <p>F15.38 presents that when the number of pulse input by the DI terminals (set as No. 51 function) reaches a specified quantity, the DO terminals or relay will send an indicating signal until the pulse number hits the preset counting value.</p> <p>For instance:</p> <p>If F15.37 is set to 7 and F15.38 is set to 3, DO1 selects preset count arriving function (F15.18 = 23), DO2 selects specified count arriving (F15.19 = 24), and DI1 selects counter trigger signal input function (F15.00 = 51).</p> <p>Sequence of counting value arriving is shown in figure:</p> <ul style="list-style-type: none"> • DO2 will output an indicating signal when DI1 inputs the third pulse until the preset count value reaches seven. • DO1 will output an indicating signal when DI1 inputs the seventh pulse; output signal of DO1 returns to low level when DI1 inputs the eighth pulse. 	
F15.39	Analogue input over-limitation selection	0000 - 1133 [0000]
	<p>If the corresponding analog > F15.40 or analog < F15.41, and continued F15.42 time, the overrun check. After the limit detection, when F15.41 ≤ analog ≤ F15.40, according to thousands to determine whether the automatic operation of the inverter.</p> <p>Unit: Action drive when the input exceeds the limit Hundred: Analog overrun detection conditions</p> <ul style="list-style-type: none"> • 0: Free stop. • 1: Emergency shutdown. • 2: Dec. stop. • 3: No action. <p>Ten: Select the analog input port</p> <ul style="list-style-type: none"> • 0: No analog port. • 1: Operation panel potentiometer. • 2: AI1 port. • 3: AI2 port. <p>Thousand: Automatical selection when analog overrun is detected</p> <ul style="list-style-type: none"> • 0: Do not allow automatic operation. • 1: Allows automatic operation. <p><i>Note: Thousand are valid only in terminal two-wire mode.</i></p>	
F15.40	Analog input overrun upper limit	F15.41 - 100.0 [100.0%]
F15.41	Analog input overrun down limit	0.0 - F15.40 [0.0%]
F15.42	Analog overrun detection time	0.00 - 50.00 [5.00s]
F15.43	Terminal output delay	0.0 - 100.0[0.0s]
F15.44	Start analog overrun detection time	0.00 - 50.00 [15.00s]

6.2.15 F16: Analogue I/O Terminal Parameters

Ref. Code	Function Description	Setting Range [Default]
F16.00	Display panel with potentiometer function	0 - 19 [0]
F16.01	AI1 function	0 - 19 [2]
F16.02	AI2 function	0 - 19 [5]
F16.03	AI3 function	0 - 19 [0]
F16.04	AI4 function	0 - 19 [0]
	<p>Note:</p> <ol style="list-style-type: none"> Only when using keypad with potentiometer can F16.00 is enabled. Only when using HD30-EIO will F16.03 and F16.04 be enabled. <p>0: Unused.</p> <p>1: Upper limit frequency setting source.</p> <ul style="list-style-type: none"> When F00.07 = 1 (upper limit frequency setting source is set by analogue input), the upper limit frequency will be set by the input voltage value corresponding to the analogue source which selects this function. <p>2: Frequency setting source.</p> <ul style="list-style-type: none"> When F00.10 = 3 (frequency setting source is set by analogue input), the setting frequency will be set by the input voltage value corresponding to the analogue source which selects this function. <p>3: Auxiliary frequency reference.</p> <ul style="list-style-type: none"> When F19.00 = 4 (auxiliary frequency reference is set by AI analogue), the auxiliary frequency will be set by the input voltage value corresponding to the analogue source which selects this function. <p>4: Process PID reference.</p> <ul style="list-style-type: none"> When F04.01 = 1 (process PID reference is set by AI analogue), the process PID reference will be set by the input voltage value corresponding to the analogue source which selects this function. <p>5: Process PID feedback.</p> <ul style="list-style-type: none"> When F04.02 = 0 (AI analogue inputs process PID feedback), the process PID feedback will be set by the input voltage value corresponding to the analogue source which selects this function. <p>6: Process PID regulating upper limit.</p> <ul style="list-style-type: none"> When F04.11 = 1 (upper limit value of the PID regulator is set by AI analogue), the process PID regulating upper limit will be set by the input voltage value corresponding to the analogue source which selects this function. <p>7: Process PID regulating lower limit.</p> <ul style="list-style-type: none"> When F04.12 = 1 (lower limit value of the PID regulator is set by AI analogue), the process PID regulating lower limit will be set by the input voltage value corresponding to the analogue source which selects this function. <p>8: Motor overheating signal input.</p> <ul style="list-style-type: none"> Connect electronic thermistor embedded motor stator coils to the inverter's analogue input, see 8.1. Refer to parameters F20.06 and F20.07 about the thermistor. <p>9: Motor 1 forward rotation torque limit.</p> <ul style="list-style-type: none"> When F10.09 unit = 1 (motor 1 forward rotation torque limit channel set by analog), motor 1 forward rotation torque limit is set by corresponding voltage of the analogue channel. <p>10: Motor 1 reverse electric torque limit.</p> <ul style="list-style-type: none"> When the F10.09 ten=1 (motor 1 reverse rotation torque limit channel set by analog), motor 1 for reverse rotation torque limit is set by corresponding voltage of the analogue channel. <p>11: Motor 1 forward regeneration rotation torque limit.</p> <ul style="list-style-type: none"> When F10.10 unit = 1 (motor 1 forward rotation torque limit channel set by analog), motor 1 forward regeneration rotation torque limit is set by corresponding voltage of the analogue channel. 	

Ref. Code	Function Description	Setting Range [Default]
	<p>12: Motor 1 reverse regeneration rotation torque limit.</p> <ul style="list-style-type: none"> When F10.10 unit = 1 (motor 1 reverse rotation torque limit channel set by analog), motor 1 reverse regeneration rotation torque limit is set by corresponding voltage of the analogue channel. <p>13: Torque command given.</p> <ul style="list-style-type: none"> When F21.00 = 1 (channel for torque command given is set by analog), torque is set by input voltage corresponding analogue channel of this selected function. <p>15: Torque control up limit frequency.</p> <ul style="list-style-type: none"> When F21.04 = 2 (controlled by speed of limit torque control by analogue), speed limit is set by input voltage corresponding analogue channel of this selected function. <p>16: Motor 2 Forward rotation electrical torque limit.</p> <ul style="list-style-type: none"> When F13.44 unit = 1 (channel of Forward rotation electrical torque limit is set by analogue), motor 2 Forward rotation electrical torque limit is set by input voltage corresponding analogue channel of this selected function. <p>17: Motor 2 reverse rotation electrical torque limit.</p> <ul style="list-style-type: none"> When F13.44 ten = 1 (channel of reverse rotation electrical torque limit is set by analogue), motor 2 reverse rotation electrical torque limit is set by input voltage corresponding analogue channel of this selected function. <p>18: Motor 2 Forward regeneration torque limit.</p> <ul style="list-style-type: none"> When F13.45 unit = 1 (motor 2 Forward regeneration torque limit is set by analogue), motor 2 Forward regeneration torque limit t is set by input voltage corresponding analogue channel of this selected function. <p>19: Motor 2 reverse regeneration torque limit.</p> <ul style="list-style-type: none"> When F13.45 ten = 1 (motor 2 reverse regeneration torque limit is set by analogue), motor 2 reverse regeneration torque limit t is set by input voltage corresponding analogue channel of this selected function. 	
F16.05	AI1 bias	-100.0 - 100.0 [0.0%]
F16.08	AI2 bias	
F16.11	AI3 bias	
F16.14	AI4 bias	
F16.06	AI1 gain	-10.00 - 10.00 [1.00]
F16.09	AI2 gain	
F16.12	AI3 gain	
F16.15	AI4 gain	
F16.07	AI1 filtering time	0.01 - 10.00 [0.05s]
F16.10	AI2 filtering time	
F16.13	AI3 filtering time	
F16.16	AI4 filtering time	
	<p><i>Note: Only when using HD30-EIO will F16.11 - F16.16 be enabled.</i></p> <p>When select AI1 - AI4 inputs as open-loop frequency setting source, the relationship between the analogue input and the setting frequency is shown as figure:</p> <pre> graph LR A[Analogue actual value] --> B[Analogue input filtering] B --> C[Analogue input gain Analogue input bias] C --> D[Analogue value after calculating] E[AI display value] --> B F[AI display value (after calculating)] --> C </pre> <p>The analogue voltage results from setting frequency signal disposed by analogue input filtering, bias and gain. The relationship between the analogue voltage and the setting frequency is set by parameters of Group F05.</p>	

Ref. Code	Function Description	Setting Range [Default]
	<ul style="list-style-type: none"> Analogue input gain and bias are involved in analogue calculation is as following formula: $Y = kX + b$. Here: Y is the calculated analogue, X is the value before adjusting, k is the analogue input gain (F16.06, F16.09, F16.12, F16.15), and b is the analogue input bias (F16.05, F16.08, F16.11, F16.14). F16.07, F16.10, F16.13, F16.16 define the filtering time. It is used to filter the analogue signal. The longer the filter time is, the higher the immunity level is, but the response time is prolonged. That is, the shorter the filter time is, the quicker the response time is, but the lower the immunity level. When current input is selected for AI2, 2 and 3 pins of jumper CN6 on control board should be shorted. 	
F16.17	Max. input pulse frequency When set the DI6 terminal as pulse input, F16.17 defines the max. input pulse frequency.	0.0 - 50.0 [10.0kHz]
F16.18	Input pulse filtering time It is used to filter the input pulse frequency and filter out the small fluctuations in the pulse frequency.	0 - 500 [10ms]
F16.19	AO1 function	0 - 20 [2]
F16.20	AO2 function	0 - 20 [0]
F16.21	High-speed pulse output function 0: Unused. 1,2: Output frequency, reference frequency (0 - max. output frequency). 3: Motor RPM (0 - max. output frequency corresponding to RPM). 4: Output current (0 - twice motor's rated current). 5: Output current (0 - twice motor's rated current). 6: Torque command (0 - 3 times motor rated torque). 10: Output torque (0 - 3 times motor's rated torque). 11: Output voltage (0 - 1.2 times inverter's rated voltage). 12: Bus voltage (0 - 2.2 times inverter's rated voltage). 13: Output power (0 - twice motor's rated power). 14: AI1 input (0 - 10V). 15: AI2 input (-10 - 10V / 0 - 20mA). 16: AI3 input (-10 - 10V / 0 - 20mA). 17: AI4 input (-10 - 10V / 0 - 20mA). 18,19: Output frequency, reference frequency (-1 times - 1 times max. output frequency). 20: Set frequency (0 - max. output frequency).	0 - 20 [0]
F16.22	Analogue output AO1 bias	-100.0 - 100.0 [0.0%]
F16.23	Analogue output AO1 gain If the user needs to adjust the proportional relationship of the AO1, it can be realized by the output gain.	0.0 - 200.0 [100.0%]
	<ul style="list-style-type: none"> Analog output gain and offset participation in the analog calculation formula: Actual output = F16.23 × Calculated value + F16.22 <div style="display: flex; justify-content: space-around;"> <div style="text-align: center;"> <p>F16.22=50% F16.23=50%</p> </div> <div style="text-align: center;"> <p>F16.22=0 F16.23=200%</p> </div> </div> <ul style="list-style-type: none"> AO1 analog output can be 0 - 20mA current signal output through 2, 3pin short of CN7, CN8. Achieve 4 - 20mA current signal output: F16.22 is set to 20.0%, F16.23 is set to 80.0% (4mA corresponds to 0% of analog output, 20mA corresponds to 100% of analog output). 	

Ref. Code	Function Description	Setting Range [Default]
F16.24	Analogue output AO2 bias	-100.0 - 100.0 [0.0%]
F16.25	Analogue output AO2 gain Refer to parameters F16.22 and F16.23.	0.0 - 200.0 [100.0%]
F16.26	DO2 max. output pulse frequency It defines the DO2 terminal allowable max. output frequency.	0.1 - 50.0 [10.0kHz]
F16.27	Keypad potentiometer offset	-100.0 - 100.0 [0.0%]
F16.28	Keypad potentiometer gain	0.00 - 10.00 [1.00]

6.2.16 F17: SCI Communication Parameters

Ref. Code	Function Description	Setting Range [Default]
F17.00	Data format	0 - 6 [0]
	0: 1-8-2 format, no parity, RTU. 1: 1-8-1 format, even parity, RTU.	2: 1-8-1 format, odd parity, RTU. 6: 1-8-11 format, no parity, RTU.
F17.01	Baud rate selection	0 - 8 [3]
	0: 1200bps. 1: 2400bps. 2: 4800bps.	3: 9600bps. 4: 19200bps. 5: 38400bps.
F17.02	Local address	0 - 247 [2]
	F17.02 = 0, it means broadcast address.	
F17.03	Host PC response time	0 - 1000 [1ms]
F17.04	Time threshold for detecting communication status	0.0 - 600.0 [0.0 s]
	When the time at no communication data exceeds the setting time of F17.04, it will be considered as communication time out. • F17.04 = 0, it will not detect communication time out.	
F17.05	Detecting time at communication error	0.0 - 600.0s [0.0]
	When the time at communication error exceeds the setting time of F17.05, it will be considered as communication error detection. • F17.05 = 0, it will not detect the communication error.	
F17.06	Action selection at communication time out	0 - 3 [3]
F17.07	Action selection at communication fault	0 - 3 [3]
F17.08	Action selection at communication peripheral device fault	0 - 3 [1]
	F17.06 defines the action selection at communication time out. F17.07 defines the action selection at communication fault. In the communication command setting mode, F17.08 will define the action selection when communication peripheral device fault is alarmed. 0: Coast to stop. 1: Emergency stop. 2: Dec. to stop. 3: Continue to run.	
F17.09	Communication write function parameter of storage EEPROM method selection	00 - 11 [01]
	When used to change parameter in selecting communication, whether stored in EEPROM or not. Unit: Except of F00.13, F19.03, EEPROM storage selection in communication 0: Not stored in EEPROM. 1: Stored in EEPROM. Ten: For F00.13, F19.03, EEPROM storage selection in communication 0: Not stored in EEPROM. 1: Stored in EEPROM. <i>Note:</i> 1. When 10 is set to 1, it may damage the inverter. Please be careful. 2. Only when using the communication write function parameter, and function code is 0x06 or 0x10, will F17.09 be valid. Refer to of Appendix C for details.	
F17.10	Detecting time of network communication overtime	0.0 - 600.0 [0.0s]
	The time interval between two received correct data (including local or non-native data) continues to exceed F17.10 and is detected for communication timeout. The timeout is checked and the timeout protection is selected according to F17.06. • F17.10 = 0, the communication timeout is not detected.	

6.2.17 F18: Display Control Parameters

Ref. Code	Function Description	Setting Range [Default]
F18.00	Language selection Only when using LCD keypad will F18.00 be enabled. 0: Chinese. 1: English.	0,1 [0]
F18.01	Displaying contrast of the LCD keypad To select LCD displaying contrast. • Only when using LCD keypad will F18.01 be enabled.	1 - 10 [5]
F18.02	Set the display parameter 1 during operation	0 - 49 [8]
F18.03	Set the display parameter 2 during operation	0 - 49 [7]
F18.04	Set the display parameter 3 during operation	0 - 49 [9]
F18.05	Set the display parameter 4 during operation	0 - 49 [13]
F18.06	Set the display parameter 5 during operation	0 - 49 [14]
F18.07	Set the display parameter 6 during operation	0 - 49 [18]
F18.08	Set the display parameter 1 at stop	0 - 49 [7]
F18.09	Set the display parameter 2 at stop	0 - 49 [18]
F18.10	Set the display parameter 3 at stop	0 - 49 [20]
F18.11	Set the display parameter 4 at stop	0 - 49 [22]
F18.12	Set the display parameter 5 at stop	0 - 49 [43]
F18.13	Set the display parameter 6 at stop Defines the contents of the operation panel display. Can be loop displayed by the key ► of keypad operation status and stop status. 0: Unused. 1: Inverter's rated current. 3: The inverter status. • Refer to parameter d00.10. 4: Master setting frequency source. 5: Master setting frequency. 6: Auxiliary setting frequency. 7: Setting frequency. 8: Reference frequency (after Acc. / Dec.). 9: Output frequency. • At running state, Hz indicator is flashing. 10: Setting RPM. 11: Running RPM. • At running state, RPM indicator is flashing. 13: Output voltage. 14: Output current. 15: Torque given. 16: Output torque. 17: Output power. 18: DC bus voltage. 19: Potentiometer input voltage. 20: AI1 input voltage. 21: AI1 input voltage (after disposal). 22: AI2 input voltage. 23: AI2 input voltage (after disposal). 24: AI3 input voltage. 25: AI3 input voltage (after disposal). 26: AI4 input voltage. 27: AI4 input voltage (after disposal). 28: DI6 terminal pulse input frequency. 29: AO1 output. 30: AO2 output. 31: High-speed output pulse frequency. 32: Heatsink temperature. 33: Set the line speed. 34: Reference line speed. 37: Process PID reference. 38: Process PID feedback. 39: Process PID error. 40: Process PID integral value. 41: Process PID output. 42: External counting value. 43: Input terminal status. • Bit0 - Bit8 are corresponding to DI1 - DI9. 44: Output terminal status. • Bit0 - Bit5 are corresponding to DO1, DO2, RLY1 - RLY4. 45: MODBUS communication status. 46: Actual length. 47: Total length. 48: Total time at power on (hour). 49: Total time at running (hour).	0 - 49 [44]
F18.14	Frequency display gain	0.1 - 160.0 [1.0]
F18.15	Max. line speed	0 - 65535 [1000]

Ref. Code	Function Description	Setting Range [Default]
F18.16	Line speed display accuracy 0: Integer. 1: One decimal. 2: Two decimal. 3: Three decimal. <i>Note: The max. linear velocity must be newly set when the display accuracy is changed.</i>	0 - 3 [0]

6.2.18 F19: Function-boost Parameters

Frequency auxiliary setting sources (F19.00 - F19.06)

The multi-step frequency of HD30 is the result of both master setting frequency and auxiliary setting frequency.

F19.00 defines the auxiliary frequency setting sources. When the auxiliary frequency setting source is the same as the master frequency setting source (except analogue setting), the auxiliary frequency setting source will be disabled.

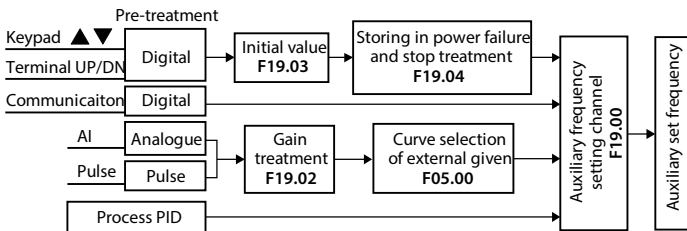
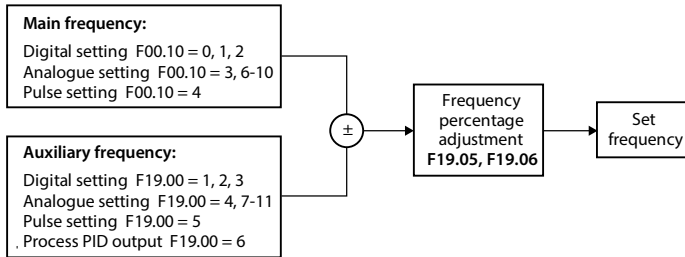

Ref. Code	Function Description	Setting Range [Default]
F19.00	Auxiliary frequency setting source selection It defines the setting source of the auxiliary frequency. <ul style="list-style-type: none"> When set F19.00 as 1, 2, the initial value is set by F19.03. When set F19.00 as 4, 5, 7 - 10, the initial value is set by the actual analogue input. Refer to F05.00 about the frequency relation characteristic curve selections. When set F19.00 as 6, set the auxiliary setting frequency according to the relationship of PID setting and feedback. Please refer to the above figure. 0: No auxiliary source.	0 - 11 [0]

Ref. Code	Function Description	Setting Range [Default]																																											
	1: Keypad setting, adjusted by ▲ and ▼ keys on the keypad. 2: Terminal setting, adjusted by terminal UP / DN. 3: SCI communication setting. The initial value is 0. 4: AI analogue setting. 5: Terminal pulse setting. 6: Process PID output. 7 - 10: AI1 - AI4. 11: Keypad potentiometer.																																												
F19.01	Master/Auxiliary setting calculation	00 - 41 [10]																																											
	Define the relationship between final setting frequency and main / aux frequency. Switch frequency by No. 54 function of DI terminal (switching main/aux frequency source). Unit: Main and auxiliary operations 0: Master setting + auxiliary setting. 1: Master setting - auxiliary setting.	Ten: Frequency source switch selection 0: Main. 1: Main and auxiliary operations. 2: Main and auxiliary switching. 3: Master and main auxiliary operation switch. 4: Auxiliary and main auxiliary operation switch.																																											
	<table border="1"> <thead> <tr> <th rowspan="2">DI=54</th> <th colspan="10">F19.01 setting value</th> </tr> <tr> <th>00</th> <th>10</th> <th>20</th> <th>30</th> <th>40</th> <th>01</th> <th>11</th> <th>21</th> <th>31</th> <th>41</th> </tr> </thead> <tbody> <tr> <td>0</td> <td>Main</td> <td>Main+Aux</td> <td>Aux</td> <td>Main+Aux</td> <td>Main+Aux</td> <td>Main</td> <td>Main-Aux</td> <td>Aux</td> <td>Main-Aux</td> <td>Main-Aux</td> </tr> <tr> <td>1</td> <td>Main</td> <td>Main+Aux</td> <td>Main</td> <td>Main</td> <td>Aux</td> <td>Main</td> <td>Main-Aux</td> <td>Main</td> <td>Main</td> <td>Aux</td> </tr> </tbody> </table>	DI=54	F19.01 setting value										00	10	20	30	40	01	11	21	31	41	0	Main	Main+Aux	Aux	Main+Aux	Main+Aux	Main	Main-Aux	Aux	Main-Aux	Main-Aux	1	Main	Main+Aux	Main	Main	Aux	Main	Main-Aux	Main	Main	Aux	
DI=54	F19.01 setting value																																												
	00	10	20	30	40	01	11	21	31	41																																			
0	Main	Main+Aux	Aux	Main+Aux	Main+Aux	Main	Main-Aux	Aux	Main-Aux	Main-Aux																																			
1	Main	Main+Aux	Main	Main	Aux	Main	Main-Aux	Main	Main	Aux																																			
F19.02	Analogue auxiliary setting coefficient	0.00 - 9.99 [1.00]																																											
	First, calculate the gain by using F19.02, then calculate auxiliary frequency according to the frequency characteristic curve of Group F05. When F19.00 = 4, 5, 7-10, F19.02 is enabled.																																												
F19.03	Initial value of digital auxiliary frequency	0.00 - F00.06 [0.00]																																											
	Only when F19.00 = 1 or 2 will F19.03 be enabled and provide the initial value for the two methods.																																												
F19.04	Control selection of digital auxiliary frequency	00 - 11 [00]																																											
	Only when F19.00 = 1 or 2 will F19.04 be enabled. Unit: Save selection at power outage <ul style="list-style-type: none"> 0: Not save auxiliary frequency at power outage. 1: The auxiliary frequency will be saved to F19.03 at power outage. Ten: Frequency disposal when the inverter stops <ul style="list-style-type: none"> 0: Maintain the auxiliary frequency when the inverter stops. 1: The auxiliary frequency clears to zero when the inverter stops. 																																												
F19.05	Adjustment selection of setting frequency	0 - 2 [1]																																											
F19.06	Adjustment coefficient of setting frequency	0.0 - 200.0 [100.0%]																																											
	F19.05 and F19.06 is to set the adjustment mode of setting frequency (the compounded frequency is computed by master setting frequency plus auxiliary setting frequency). 0: No adjustment. <ul style="list-style-type: none"> Setting frequency = synthetic frequency. 1: To adjust as per the max. output frequency of F00.06. <ul style="list-style-type: none"> Setting frequency = synthetic frequency + F00.06 × (F19.06 - 100%). 2: To adjust as per the current frequency. <ul style="list-style-type: none"> Setting frequency = synthetic frequency × F19.06. 																																												

Fan control (F19.07 - F19.08)

Ref. Code	Function Description	Setting Range [Default]
F19.07	Control selection of cooling fan	0 - 2 [0]
F19.08	Cooling fan controls delaying time	0.0 - 600.0 [60.0s]

0: Auto stop mode.

- The fan runs all the time when the inverter is in running status. After the inverter stops for the time set by F19.08, the fan stops if the inverter is not overheated. The fan will continue running if the overheat protection is activated.

1: Immediate stop mode.

- The fan runs all the time when the inverter is in running status and stops when the inverter stops.

2: The fan runs continuously when power on.

- The fan runs continuously after the inverter is switched on.

Zero-frequency operation (F19.10 - F19.11)

Refer to below figure for the details.

Fcmd = Setting frequency

Fmin = Zero-frequency threshold (F19.10)

Flow = Lower limit frequency (F00.09)

H = Target frequency

Fstart = Start DWELL frequency (F02.02)

F02.03 (Keeping time of start frequency)

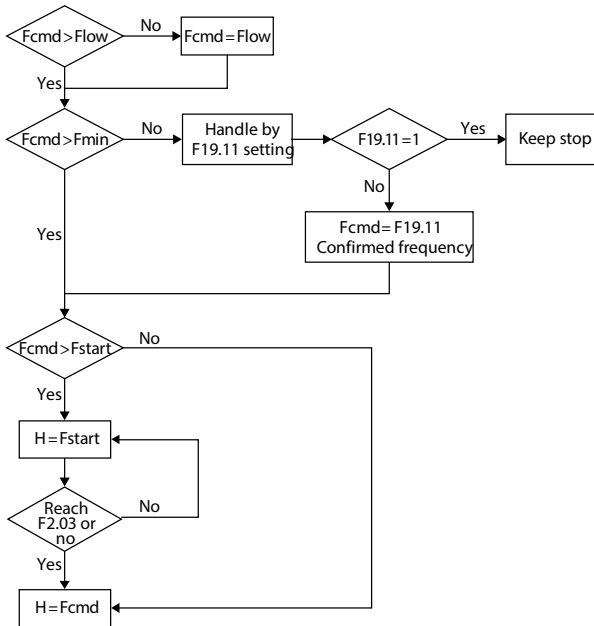

Ref. Code	Function Description	Setting Range [Default]
F19.10	Zero-frequency threshold	0.00 - upper limit [1.00Hz]
F19.11	Action selection at setting frequency is lower than zero-frequency threshold 0: Run according to frequency command. 1: Holding stop, no output. 2: Run according to zero-frequency threshold. 3: Run according to zero-frequency.	0 - 3 [0]

Trip-free operation during momentary power loss (F19.12 - F19.15)

The inverter can automatically perform low-voltage compensation when the voltage decreases or instantaneous under-voltage occurs. The inverter can continue to operate without tripping by reducing its output frequency and feedback energy via motor.

Ref. Code	Function Description	Setting Range [Default]						
F19.12	Trip-free selection at momentary power loss If the inverter is momentarily lost during running (main circuit DC bus voltage $V_{DC} < F19.15$), the inverter maintains the DC bus voltage by reducing the output frequency to avoid undervoltage shutdown. 0: This function is disabled. 1: This function is enabled. And low-voltage compensation is activated.	0,1 [0]						
F19.13	Dec. time at voltage compensation When the instantaneous stop is enabled, the inverter will judge the voltage difference, the voltage compensation gain according to the current DC bus voltage and the F19.15 instantaneous stop operation, adjust the output frequency in real time, and maintain the DC bus voltage to avoid the undervoltage shutdown. • If F19.13 is set too small, the feedback energy of motor will be too large and overvoltage protection might be activated. • If F19.13 is set too big, the feedback energy of motor will be too small to achieve voltage compensation effect.	0.1 - 6000.0 [5.0s]						
F19.15	Reference voltage of trip-free operation at momentary power loss	<table border="1"> <tr> <td>220V inverter:</td> <td>210 - 370 [248V]</td> </tr> <tr> <td>380V inverter:</td> <td>400 - 670 [430V]</td> </tr> <tr> <td>660V inverter:</td> <td>620 - 1130 [747V]</td> </tr> </table>	220V inverter:	210 - 370 [248V]	380V inverter:	400 - 670 [430V]	660V inverter:	620 - 1130 [747V]
220V inverter:	210 - 370 [248V]							
380V inverter:	400 - 670 [430V]							
660V inverter:	620 - 1130 [747V]							

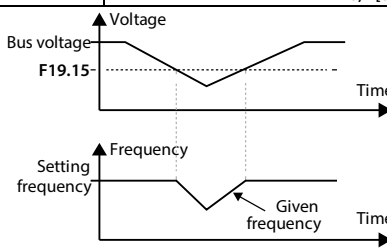

Restart after power failure (F19.16 - F19.17)

This function decides in different control modes whether the inverter starts automatically or not and the delay time for restart when the inverter is switched off and then switched on.

Ref. Code	Function Description	Setting Range [Default]
F19.16	Restart after power failure 0: This function is disabled. 1: This function is enabled. In the terminal two-wire control mode and suddenly power failure during running process, when the inverter is powered on again and the terminal is still enabled, it will wait certain time defined by F19.17 and then start operation automatically.	0,1 [0]

F19.17	Delay time for restart after power failure	0.00 - 10.00 [2.00s]
--------	--	----------------------

Protection of stall overvoltage (F19.18 - F19.19)

During Dec., the motor's decelerate rate may be lower than that of the inverter's output frequency due to the load inertia. At this time, the motor will feed the energy back to the inverter, resulting in voltage rise on the inverter's DC bus. If no measures taken, the inverter will trip due to overvoltage.

Ref. Code	Function Description	Setting Range [Default]
F19.18	Overvoltage suppression gain	0.000 - 1.000 [0.500]
	0: Overvoltage stall is prohibited. 0.001 - 1.000: Turn on overvoltage stall. <ul style="list-style-type: none"> It in running, he bus voltage is greater than F19.19 overvoltage stall when the bus voltage is compared with F19.19, the inverter automatically increases the output frequency to avoid more energy being fed back to converter by the load. Overvoltage suppression gain setting is too small to effectively suppress DC bus voltage rise. The overvoltage suppression gain setting is too large, which may cause the output frequency to fluctuate and cause the whole system to oscillate. The deceleration time may be appropriate to increase during deceleration to avoid the system shock caused by overvoltage stall. Note: When the overvoltage stall condition is held for more than 1 minute, the inverter reports overvoltage stall failure (E0007) and stops the output.	
F19.19	Stall overvoltage point	220V inverter: 350 - 400 [390V]
		380V inverter: 650 - 790 [690V]
		660V inverter: 900 - 1180 [1150V]
When the inverter is overvoltage during operation, it is possible to increase the overvoltage stall gain and reduce the overvoltage stall. <p>Overvoltage stall with brake components:</p> <ul style="list-style-type: none"> Overvoltage stall should normally be disabled (F19.18 = 0) when the brake assembly is installed in the inverter. The inverter may be overvoltage protected when the energy is instantaneously fed back and the braking components can not release the feedback energy in time. In this case, overvoltage protection can be avoided by enabling overvoltage stall. The value of the stall point (F19.19) should be greater than the operating voltage point of the brake assembly. 		

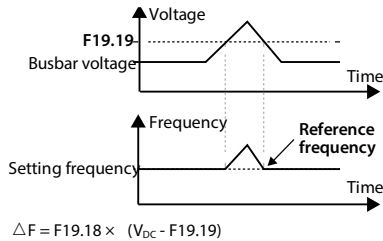

Auto current limiting function (F19.20 - F19.21)

Auto current limiting function is used to limit the load current in real time smaller than the auto current limiting threshold (F19.21). Therefore the inverter will not trip due to surge current. This function is especially suitable for applications with big load inertia or big change of load.

In auto current limiting process, the inverter's output frequency may change; therefore, it is recommended not to enable this function when stable output frequency is required.

Note: When the frequency converter is used for potential load (lift, hoist, etc.), it should be forbidden to ensure the safety of the whole system: Instantaneous stop (F19.12 - F19.15), undervoltage restart (F19.16 - F19.17), overvoltage stall (F19.18 - F19.19), automatic current limiting (F19.20 - F19.22).

Ref. Code	Function Description	Setting Range [Default]
F19.20	Automatic current limiting gain	0.000 - 1.000 [0.500]
	When the inverter output current exceeds F19.21, the inverter will automatically suppress further increase of output current to avoid overcurrent protection. <ul style="list-style-type: none"> The automatic current limiting gain should be adjusted according to the actual load conditions: <ul style="list-style-type: none"> Automatic current limiting gain setting is too small to effectively suppress the increase in output current. The automatic current limit gain setting is too large, which may cause the output frequency to fluctuate and cause the entire system to oscillate. F19.20 = 0, the automatic current limit is invalid. 	
F19.21	Auto current limiting threshold	20.0 - 200.0 [G: 150%] [P: 110%]
	F19.21 defines the threshold of auto current limiting. It is a percentage of the inverter's rated current.	

Terminal detecting (F19.23)

Ref. Code	Function Description	Setting Range [Default]
F19.23	Enabled mode of terminal run command	0,1 [0]
	0: Rise edge enabled mode. <ul style="list-style-type: none"> For many applications, the inverter is not allowed to auto-run to avoid device damage and ensure safety due to no person interference at power on. In these applications, when the inverter's power is initialized and ready to run, it can not start to run until the terminal run command is given. 1: Level enabled mode. <ul style="list-style-type: none"> For certain applications, when ensured personal safety and device safety it need the inverter immediately run at power on in order to provide automation and efficiency. In these application, the inverter will immediately run as soon as the terminal run command is given whether before or after power on. 	

Braking unit (F19.24 - F19.25, F19.40 – F19.41)

Ref. Code	Function Description	Setting Range [Default]
F19.24	Action voltage of braking unit	220V inverter: 330 - 400 [380V]
		380V inverter: 630 - 750 [720V]
		660V inverter: 980 - 1120 [1130V]
<i>Note: Only the frequency converter with built-in brake unit releases energy through the braking resistor, and the energy release only occurs when the inverter is running.</i>		
F19.25	Flux brake enabled	0,1 [0]
0: Prohibited. 1: Enable, automatically disable overvoltage stall function. <ul style="list-style-type: none"> • By increasing the loss of the motor, you can decelerate faster without braking resistors. • The flux brake effect can be adjusted by F19.40, F19.41. • Valid only when V/f control is active. <i>Note: Do not use this function during frequent braking, which may damage the motor.</i>		

Fixed length arrive and stop function (F19.26 - F19.34)

This Group is used to realize fixed length stop function. As the right figure:

The inverter inputs the count pulse from the terminal (multi-function terminal is set as No. 52 function) and gets the count length according to the measuring number of pulses per revolution (F19.31) and shaft diameter (F19.30). Then modify the count length and obtain the actual length (F19.27) via length ratio (F19.28) and length checking coefficient (F19.29) too.

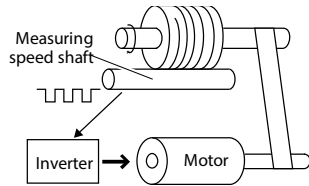

The formula is as follows:

$$F19.27 = \text{Counted length} \times F19.28 \div F19.29$$

$$\text{Counted length} = \text{Counted pulse number} \div F19.31 \times F19.30 \times \pi$$

If $F19.27 \geq F19.26$, the inverter will automatically send the stop command. Before running again, it need clear F19.27 or changed to $F19.27 < F19.26$. Otherwise the inverter can't be started.

Ref. Code	Function Description	Setting Range [Default]
F19.26	Preset length	0 - 65535 [0m]
F19.27	Actual length	0 - 65535 [0m]
F19.28	Length ratio	0.001 - 30.000 [1.000]
F19.29	Length checking coefficient	0.001 - 1.000 [1.000]
F19.30	Measuring shaft diameter	1.00 - 100.00 [10.00cm]
F19.31	Number of pulses per revolution	1 - 9999 [1]
F19.32	Length arrive and output function selection	0,1 [0]
	0: Output level signal. 1: Output 500ms pulse.	
F19.33	Record of length disposal after length arrive	0,1 [0]
F19.34	Record of length disposal at stop	0,1 [0]
	0: Auto-clear. 1: No change.	

Auxiliary PID limit (F19.35 - F19.36)

Ref. Code	Function Description	Setting Range [Default]
F19.35	Auxiliary PID output limit	0.0 - 100.0 [100.0%]
	Auxiliary frequency selected as PID, PID takes as PID adjustment up limit F19.35 × main given frequency.	
F19.36	Auxiliary PID output limit increase	0.0 - 100.0 [0.0%]
	Auxiliary PID output limit = output limit confirmed by F19.35 + F19.36 × F00.06.	

Frequency adjust range (F19.37)

Ref. Code	Function Description	Setting Range [Default]
F19.37	Frequency adjust range selection	000 - 111 [100]
	<p>Unit: The main frequency calculation range Hundred: Synthetic frequency calculation range</p> <ul style="list-style-type: none"> • 0: 0 to max. frequency. • 0: 0 to the upper limit frequency. • 1: Negative max. frequency to max. frequency. • 1: Negative upper limit frequency to upper limit frequency. <p>Ten: Auxiliary frequency calculation range</p> <ul style="list-style-type: none"> • 0: 0 to max. frequency. • 1: Negative max. frequency to max. frequency. 	

Short detection (F19.38)

Ref. Code	Function Description	Setting Range [Default]
F19.38	Phase short circuit detection action selection	0,1 [1]
	Used to select whether or not to detect a short circuit between each run. 0: No detection. 1: Detection.	

Input voltage selection (F19.39)

Ref. Code	Function Description	Setting Range [Default]
F19.39	Input voltage selection	000 - 212 [0]
	<p>Unit: 380V model input voltage selection Hundred: 660V model input voltage selection</p> <p>0: 380 - 460V. 0: 500 - 690V. 1: 260 - 460V. 1: 380 - 690V. 2: 200 - 460V. 2: 260 - 690V.</p> <p>Ten: 220V model input voltage selection <i>Note: When selecting 1, 2 function, the inverter needs to be derated, the actual output current does not exceed the rated output current of the inverter.</i></p> <p>0: 200 - 240V. 1: 120 - 240V.</p>	

Brake function (F19.24 - F19.25, F19.40 - F19.41)

Ref. Code	Function Description	Setting Range [Default]
F19.40	Flux brake PI regulator Kp	0 - 4000 [1000]
F19.41	Flux brake PI regulator Ki	0 - 500 [20]

6.2.19 F20: Protection of Fault Parameters

Overload fault (F20.00 - F20.02)

Ref. Code	Function Description	Setting Range [Default]
F20.00	Overload pre-alarm detection Unit: Overload pre-alarm detection <ul style="list-style-type: none"> 0: It is active all the time in running status. 1: It is active only at constant speed. Ten: Action selection for overload pre-alarm <ul style="list-style-type: none"> 0: The inverter doesn't alarm and continues operation when detecting an active overload signal. 1: The inverter alarms and stops operation when detecting an active overload signal. Hundred: Overload threshold selection <ul style="list-style-type: none"> 0: Ratio of load current to the motor's rated current (alarm: motor overload "E0019"). 1: Ratio of load current to the inverter's rated current (alarm: inverter overload "E0017"). Thousand: Motor type selection <ul style="list-style-type: none"> 0: Standard motor. <ul style="list-style-type: none"> As the cooling effect of the standard motor deteriorates at low speed, the inverter will automatically make regulation to the motor overload protection time. 1: Variable frequency. <ul style="list-style-type: none"> The cooling effect of the variable frequency motor is not affected by the motor's speed due to its forced cooling potential, the inverter will not automatically make regulation to the motor overload protection time, as efficient motor cooling by an external motor fan is assumed. Ten thousand: Overload protection <ul style="list-style-type: none"> 0: Overload protection is enabled. 1: Overload protection is disabled. 2: Shielded inverter overload protection, enable motor overload protection. 3: Shielded inverter overload protection, motor overload protection. 	00000 - 31111 [00000]
F20.01	Overload pre-alarm detection threshold F20.01 defines the current threshold for overload pre-alarm protection. The setting range is a percentage value of the motor's or the inverter's rated current.	20.0 - 200.0 [150.0%]
F20.02	Overload pre-alarm detection time F20.02 defines the time during which the inverter output current exceeds overload pre-alarm detection threshold (F20.01). If the status remains after overload pre-alarm detection time (F20.02), the inverter will output pre-alarm signal.	0.0 - 60.0 [5.0s]

Inverter output load-loss detection fault (F20.03 - F20.05)

Ref. Code	Function Description	Setting Range [Default]
F20.03	Inverter output load-loss detection 0: Disabled. It does not detect inverter output load-loss. 1: It is detecting all the time in running process, and then continues operation after detecting (alarm). 2: It detects only at the same speed, and then continues operation after detecting (alarm). 3: It is detecting all the time in running process, and then cut off the output after detecting (fault). 4: It is detects only at the same speed, and then cut off the output after detecting (fault).	0 - 4 [0]
F20.04	Inverter output load-loss detection threshold F20.04 defines the current threshold of load-loss. It is a percentage of the inverter's rated current.	0 - 100 [30%]
F20.05	Inverter output load-loss detection time If the inverter's output current is smaller than the load-loss detection threshold (F20.04) beyond the time defined by load-loss detection time (F20.05), the inverter will alarm inverter load-loss fault (E0018). • F20.04 = 0 or F20.05 = 0, the inverter will not detect load loss fault.	0.00 - 20.00 [1.00s]

Motor overheating fault (F20.06 - F20.07)

It can connect the electronic thermistor embedded motor stator coils to the inverter's analogue input in order to protect motor overheating. The connection is shown as section 8.1 HD30-EIO, on page 125.

Ref. Code	Function Description	Setting Range [Default]
F20.06	Motor overheating signal input type 0: Does not detect the motor overheating. 1: Positive characteristic (PTC). 2: Negative characteristic (NTC). <i>Note: Only when using HD30-EIO will F20.06 be enabled. It need correctly set the jumpers of CN3 and CN4 to detect the motor overheating.</i>	0 - 2 [0]
F20.07	Thermistor value at motor overheating	0 - 10.0 [5.0kΩ]

Input and output phase loss fault (F20.08 - F20.11)

Ref. Code	Function Description	Setting Range [Default]
F20.08	Input phase loss detection reference	0 - 80 [30%]
F20.09	Input phase loss detection time F20.08 value is a percentage of the inverter's rated voltage. When the inverter detects certain input voltage not hit the preset detection reference (F20.08) and exceed the preset detection time (F20.09), the inverter will perform input phase loss alarm (E0015). • F20.08 = 0, the inverter will not detect input phase loss fault.	1.00 - 5.00 [1.00s]
F20.10	Output phase loss detection reference	0 - 100 [20%]
F20.11	Output phase loss detection time F20.10 value is a percentage of the inverter's rated current. When the inverter detects certain output current not hit the preset detection reference (F20.10) and exceed the preset detection time (F20.11), the inverter will perform output phase loss alarm (E0016). • F20.10 = 0, the inverter will not detect output phase loss fault.	1.00 - 20.00 [3.00s]

PID fault (F20.12 - F20.17)

Ref. Code	Function Description	Setting Range [Default]
F20.12	PID reference lose detected value	0 - 100 [0%]
F20.13	PID reference loss detection time F20.12 value is a percentage of the max. reference source. If the PID reference value is lower than the detected value (F20.12) in the detection time (F20.13), the inverter will alarm PID reference loss alarm (E0025). • F20.12 = 0 or F20.13 = 0, the inverter will not detect PID reference loss fault.	0.0 - 10.0 [0.20s]
F20.14	PID feedback loss detected value	0 - 100 [0%]
F20.15	PID feedback loss detection time F20.14 value is a percentage of the max. feedback source. If the PID feedback value is lower than the detected value (F20.14) in the detection time (F20.15), the inverter will implement PID feedback loss alarm (E0026). • F20.14 = 0 or F20.15 = 0, the inverter will not detect PID feedback loss fault.	0.0 - 10.0 [0.20s]
F20.16	Detection value at PID feedback out of the limit	0 - 100 [100%]
F20.17	Detection time at PID feedback out of the limit F20.16 value is a percentage of the max. feedback source. If the PID feedback value exceed the detection value (F20.16) in the detection time (F20.17), the inverter will alarm PID feedback out of limiting (E0027). • F20.16 = 0 or F20.17 = 0, the inverter will not detect PID feedback out of limiting fault.	0.00 - 10.00 [0.20s]

Faulted auto reset function and faulted relay action (F20.18 - F20.20)

Auto reset function enables the inverter to reset the fault as per the preset F20.18 and F20.19.

During the reset interval, the inverter stops output and it will automatically restarts with flying start mode.

The following faults do not have the auto reset function:

E0008: Power modular fault

E0021: Control board EEPROM read/write fault

E0010: Braking unit fault

E0023: Parameter setting fault

E0013: Contactor isn't closed at power on

E0024: Peripheral device fault

E0014: Current detection circuit fault

Ref. Code	Function Description	Setting Range [Default]
F20.18	Auto reset times	0 - 100 [0]
F20.19	Auto reset interval When F20.19 = 0, it means "auto reset" is disabled and the protective device will be activated in case of fault. • If no other fault is detected within 5 minutes, the auto reset times will be automatically cleared. • On condition of external fault reset, auto reset time will be cleared.	0.01 - 200.00 [5.00s/time]
F20.20	Faulted relay action selection Unit: In auto reset process • 0: Faulted relay doesn't act. • 1: Faulted relay acts. Ten: In the undervoltage process • 0: Faulted relay doesn't act. • 1: Faulted relay acts. <i>Note: It need preset the relay function as No. 31 function.</i>	00 - 11 [00]

Fault history (F20.21 - F20.37)

Ref. Code	Function Description	Setting Range [Default]
F20.21	Type of fifth latest (the last) fault	[Actual value]
F20.22	Setting frequency at the last fault	
F20.23	Running frequency at the last fault	
F20.24	Bus voltage at the last fault	
F20.25	Output voltage at the last fault	
F20.26	Output current at the last fault	
F20.27	Input terminal status at the last fault	
F20.28	Output terminal status at the last fault	
F20.29	Interval of fifth latest fault	
F20.30	Type of fourth latest fault	
F20.31	Interval of fourth latest fault	
F20.32	Type of third latest fault	
F20.33	Interval of third latest fault	
F20.34	Type of second latest fault	
F20.35	Interval of second latest fault	
F20.36	Type of first latest fault	
F20.37	Interval of first latest fault	
F20.38	Last fault interval	
	F20.22 - F20.29 record the inverter status parameters at the last fault. F20.30 - F20.37 record the type and interval per time of four faults before the latest. The interval's unit is 0.1 hour.	

6.2.20 F21: Torque Control Parameters

Under open loop vector control, set F00.00 = 1 (torque control), the torque output can be controlled by F21 Group torque control parameter. Torque control, if the motor output torque and load torque is not balanced, the motor will be accelerated or decelerated operation.

In electric state, motor running speed is limited by speed limit value determined by F21.04, in power generation state, motor running speed changes in following of the load speed changes.

The direction of the internal torque command varies with the run command direction and the torque reference.

Running command	Torque reference polarity	Internal torque command direction
Forward rotation	Positive	Forward direction
	Negative	Reverse direction
Reverse rotation	Positive	Reverse direction
	Negative	Forward direction

Ref. Code	Function Description	Setting Range [Default]
F21.00	Torque command given channel selection	0 - 3 [0]
	0: F21.01 digital set. 1: Analogue set. 2: Terminals pulse set. 3: SCI communication set.	
F21.01	Torque command digital setting	-100.0 - 100.0 (F21.02) [0.0%]
	Definite torque given value when F21.00 = 0.	
F21.02	Max. Torque setting	0.0 - 500.0 (F08.04) [100.0%]
	Definite allowable max. torque of output.	
F21.03	Filter time of torque command	0.000 - 1.000 [0.000s]
	Defines the time through which the external torque command passes through a delay filter through the torque reference channel. • Set the appropriate filter time to prevent motor jitter due to mutations in the torque command.	
F21.04	Speed limit selection in torque control	0 - 2 [1]
	0: Defined by F21.05, F21.06. 1: Defined by F00.06 (max. output frequency). 2: Limited by analog quantity. When the AI terminal (F16.01 - F16.04) is set to function No. 15, the speed is limited by analog.	
F21.05	Positive speed limit selection in torque control	0 - 100 (F00.06) [100%]
F21.06	Reverse speed limit selection in torque control	0 - 100 (F00.06) [100%]
	Definite speed limit value of positive and reverse running under torque control mode (F00.00 = 1).	
F21.10	Stop mode selection of torque control	0 - 2 [0]
	0: Dec. stop + DC braking. • When the inverter receives the stop command, the output frequency starts from the set Dec. time when the stop command is valid. When the frequency set in F02.16 is reached, the DC braking is started. Stop DC braking function see F02.16 - F02.18. 1: Stop torque output. • The inverter stops the torque output after receiving the stop command, and the motor is completely dragged by the load. 2: Free stop. • When the inverter receives the stop command, the inverter terminates the output immediately and the load stops at the mechanical inertia.	

6.2.21 F23: PWM Control Parameters

Ref. Code	Function Description	Setting Range [Default]	
F23.00	Set the carrier frequency	1 - 16kHz [Dependent on HD30]	
	F23.00 defines the carrier frequency of PWM output wave.		
	Inverter power	Setting range	Factory setting
	0.2 - 22kW	1k - 8kHz	8kHz
	30kW - 45kW	1k - 6kHz	6kHz
	45kW	1k - 6kHz	4kHz
	55kW and above	1k - 4kHz	2kHz
	<ul style="list-style-type: none"> The carrier frequency will affect the operating noise of the motor. The higher the carrier frequency, the lower the noise made by the motor. Please properly set the carrier frequency. When the value is higher than the factory setting, the inverter should be derated by 5% when per 1kHz is increased compared to the factory setting. 		
F23.01	Carrier frequency is automatically adjusted	0 - 2 [1]	
	0: The carrier frequency is disabled automatically. 1: Carrier frequency auto adjustment 1. 2: Carrier frequency automatic adjustment 2. <ul style="list-style-type: none"> When the carrier frequency is automatically adjusted, the inverter automatically adjusts the carrier frequency according to the output frequency and the radiator temperature. Invalid carrier frequency auto adjustment during torque control. 		
F23.02	PWM overshoot enable	0,1 [1]	
	0: Disabled. 1: Enabled.		
F23.03	PWM modulation mode	0 - 2 [0]	
	0: Two-phase modulation or three-phase modulation. 1: Three-phase modulation. 2: Two-phase modulation.		
F23.04	PWM Modulation mode switching point1	0.00 - 50.00Hz	
F23.05	PWM Modulation mode switching point2	[Dependent on HD30]	
	PWM modulation mode switching only applies to working conditions of V/f control and carrier frequency > 3kHz; open loop vector or carrier frequency ≤ 3kHz, the inverter automatically selects the three-phase modulation. <ul style="list-style-type: none"> F23.04 sets the switching frequency of two-phase modulation → three-phase modulation. <ul style="list-style-type: none"> 2.2kW and below models (380V and 220V) factory value 10.00Hz, the lower limit of 10.00Hz. Other models, factory default 5.00Hz, lower limit 5.00Hz. F23.05 sets the switching frequency of three-phase modulation → two-phase modulation. <ul style="list-style-type: none"> 2.2kW and below models (380V and 220V) factory value 15.00Hz. Other models, factory value 10.00Hz. Note: F23.04 setting value is F23.05 - 2.00Hz, F23.05 lower limit is F23.04 + 2.00Hz.		
F23.09	Random carrier frequency coefficient K1	0 - 2000 [2]	
F23.10	Random carrier frequency coefficient K2	0 - 2000 [3]	

6.3 Group U: User Menu Mode Display Parameters

Refer to Appendix A about the record.

The concrete use is illustrated as the following example:

If you want to map F00.13 (starting frequency digital setting) to the user menu map 1 (U00.00), you only need to set U00.00 as 00.13 (corresponding to F00.13) and then you can directly control F00.13 via read-write U00.01 (setting value of map 1), which is the same effect as the direct operation of F00.13.

Ref. Code	Function Description	Setting Range [Default]
U00.00	User menu map of setting 1	00.00 - 23.05, 99.99 [00.01]
U00.02	User menu map of setting 2	00.00 - 23.05, 99.99 [00.06]
U00.04	User menu map of setting 3	00.00 - 23.05, 99.99 [00.08]
U00.06	User menu map of setting 4	00.00 - 23.05, 99.99 [00.13]
U00.08	User menu map of setting 5	00.00 - 23.05, 99.99 [00.10]
U00.10	User menu map of setting 6	00.00 - 23.05, 99.99 [00.11]
U00.12	User menu map of setting 7	00.00 - 23.05, 99.99 [02.13]
U00.14	User menu map of setting 8	00.00 - 23.05, 99.99 [03.01]
U00.16	User menu map of setting 9	00.00 - 23.05, 99.99 [03.02]
U00.18	User menu map of setting 10	00.00 - 23.05, 99.99 [08.00]
U00.20	User menu map of setting 11	00.00 - 23.05, 99.99 [08.01]
U00.22	User menu map of setting 12	00.00 - 23.05, 99.99 [08.02]
U00.24	User menu map of setting 13	00.00 - 23.05, 99.99 [08.03]
U00.26	User menu map of setting 14	00.00 - 23.05, 99.99 [08.04]
U00.28	User menu map of setting 15	00.00 - 23.05, 99.99 [99.99]
U00.30	User menu map of setting 16	00.00 - 23.05, 99.99 [99.99]
	If set as 99.99, there is no parameter map function.	
U00.01	The setting value of map 1	The same as the selected parameter[0]
U00.03	The setting value of map 2	
U00.05	The setting value of map 3	
U00.07	The setting value of map 4	
U00.09	The setting value of map 5	
U00.11	The setting value of map 6	
U00.13	The setting value of map 7	
U00.15	The setting value of map 8	
U00.17	The setting value of map 9	
U00.19	The setting value of map 10	
U00.21	The setting value of map 11	
U00.23	The setting value of map 12	
U00.25	The setting value of map 13	
U00.27	The setting value of map 14	
U00.29	The setting value of map 15	
U00.31	The setting value of map 16	

6.4 Group y: Manufacturer Function Parameters

The Group y is the manufacturer parameters Group for debugging at the factory before delivery.

Chapter 7 Troubleshooting and Maintenance

7.1 Troubleshooting

HD30 series inverter has inbuilt protective and warning self-diagnostic functions. If a fault occurs, the fault code will be displayed on the keypad. At the same time, fault relay acts, accordingly the inverter stops output and the motor coasts to stop.

When fault or alarm occurs, please record the fault details and take proper actions according to the below Table 7-1. If you need some technical help, please contact to the suppliers or directly call Shenzhen Hpmont Technology Co., Ltd.

After the fault is eliminated, please reset the inverter by any of the following methods:

1. Display panel.
2. External reset terminal (multi-function terminal set as No. 46 function).
3. Communication.
4. Switching on the inverter after switching off.

Table 7-1 Fault alarm description and counter-measures

Fault		Fault reasons	Counter-measures
-Lu-	DC bus undervoltage	<ul style="list-style-type: none"> • At the begining of powering on and at the end of powering off • Input voltage is too low • Improper wiring leads to undervoltage of hardware 	<ul style="list-style-type: none"> • It is normal status of powering on and powering off • Please check input power voltage • Please check wiring and wire the inverter properly
E0001	Inverter output overcurrent (in Acc. process)	<ul style="list-style-type: none"> • Improper connection between inverter and motor 	<ul style="list-style-type: none"> • Connect the inverter and motor properly • Please set correct motor parameters (F08.00 - F08.04, F13.01 - F13.05) • Select inverter with higher rating • Please set proper Acc. time and Dec. time (F03.01 - F03.08) • Please set start mode to be speed tracking (F02.00 = 2)
E0002	Inverter output overcurrent (in Dec. process)	<ul style="list-style-type: none"> • Improper motor parameters • The rating of the used inverter is too small 	
E0003	Inverter output overcurrent (in constant speed process)	<ul style="list-style-type: none"> • Acc. / Dec. time is too short • Instant stop occurs, the running motor is restarted 	
E0004	DC bus over voltage (in Acc. process)	<ul style="list-style-type: none"> • Input voltage is too high • Deceleartion time is too short 	<ul style="list-style-type: none"> • Please check power input • Please set a proper value for Dec. time (F03.02, F03.04, F03.06, F03.08) • Please check wiring and wire the inverter properly • Please set start mode to be speed tracking (F02.00 = 2) • Select according to the recommended braking devices of user manual
E0005	DC bus over voltage (in Dec. process)	<ul style="list-style-type: none"> • Improper wiring leads to overvoltage of hardware • Instant stop occurs, the running motor is restarted 	
E0006	DC bus over voltage (in constant speed process)	<ul style="list-style-type: none"> • Improper selection of the braking devices 	

Fault		Fault reasons	Counter-measures
E0007	Stall overvoltage	<ul style="list-style-type: none"> • Bus voltage is too high • The setting of stall overvoltage is too low 	<ul style="list-style-type: none"> • Please check power input or the function of brake • Set the value of stall overvoltage properly
E0008	Fault of power module	<ul style="list-style-type: none"> • Short circuit between phases output • Short circuit to the ground • Output current is too high • Power module is damaged 	<ul style="list-style-type: none"> • Please check the connection and connect the wire properly • Please check the connection and connect the wire properly • Please check the connection and mechanism • Please contact the supplier for repairing
E0009	Heatsink overheat	<ul style="list-style-type: none"> • Ambient temperature is too high • Inverter external ventilation is not good • Fan fault • Fault occurs to temperature detection circuit 	<ul style="list-style-type: none"> • Please use inverter with higher power capacity • Improve the ventilation around the inverter • Replace the cooling fan • Please seek technical support
E0010	Fault of braking unit	<ul style="list-style-type: none"> • Circuit fault of braking unit 	<ul style="list-style-type: none"> • Please seek technical support
E0011	CPU fault	<ul style="list-style-type: none"> • CPU abnormal 	<ul style="list-style-type: none"> • Please detect at power on after completely power outage • Please seek technical support
E0012	Parameters auto-tuning fault	<ul style="list-style-type: none"> • Parameter auto-tuning is time out 	<ul style="list-style-type: none"> • Please check the motor's connection • Input the correct motor parameters (F08.00 - F08.04, F13.01 - F13.05) • Please seek technical support
E0013	Contactors is not actuated	<ul style="list-style-type: none"> • Contactor fault • Fault of control circuit 	<ul style="list-style-type: none"> • Replace the contactor • Please seek technical support
E0014	Fault of current detection circuit	<ul style="list-style-type: none"> • Current detection circuit is damaged 	<ul style="list-style-type: none"> • Please contact the supplier for repairing
E0015	Fault of input phase	<ul style="list-style-type: none"> • For three-phase input inverter, input phase loss fault occurs to power input 	<ul style="list-style-type: none"> • Please check the three-phase power input • Please seek technical support
E0016	Fault of output phase	<ul style="list-style-type: none"> • Output phase disconnection or loss • Heavy imbalance of inverter's three-phase load 	<ul style="list-style-type: none"> • Please check the connection between inverter and motor • Please check the quality of motor
E0017	Inverter overload	<ul style="list-style-type: none"> • Acc. time is too short • Improper setting of V/f curve or torque boost leads to over current • Instant power-off occurs, the running motor is restarted • Mains supply voltage is too low • Motor load is too high 	<ul style="list-style-type: none"> • Adjust Acc. time (F03.01, F03.03, F03.05, F03.07) • Adjust V/f curve (F09.00 - F09.06) or torque boost (F09.07, F09.08) • Please set start mode to be speed tracking (F02.00 = 2) • Please check mains supply voltage • Please use inverter with proper power rating

Fault		Fault reasons	Counter-measures
E0018	Inverter output is unloaded	<ul style="list-style-type: none"> Load disappeared or comes down suddenly Parameters are not set properly 	<ul style="list-style-type: none"> Please check load and mechanical transmission devices Please set the parameters properly (F20.03 - F20.05)
E0019	Motor overload	<ul style="list-style-type: none"> Improper setting of V/f curve Mains supply voltage is too low Normal motor runs for a long time with heavy load at low speed Motor's overload protection factor is not set properly Motor runs with blocked torque or load is too heavy 	<ul style="list-style-type: none"> Adjust the setting of V/f curve (F09.00 - F09.06) Check the power input Please use special motor if the motor needs to operate for a long time with heavy load Please properly set the overload protection factor of the motor Please check the load and mechanical transmission devices
E0020	Motor overheat	<ul style="list-style-type: none"> Motor overheat The setting of motor parameters is incorrect 	<ul style="list-style-type: none"> Reduce the load; Repair or replace the motor; Increase the Acc. / Dec. time (F03.01 - F03.08) Set the motor parameter (F08.00 - F08.04, F13.01 - F13.05)
E0021	Access fault of Control board EEPROM	<ul style="list-style-type: none"> Memory circuit fault of control board EEPROM 	<ul style="list-style-type: none"> Please contact the supplier for repairing
E0022	Access fault of keypad EEPROM	<ul style="list-style-type: none"> Memory circuit fault of keypad EEPROM 	<ul style="list-style-type: none"> Replace the keypad Please contact the supplier for repairing
E0023	Fault setting of parameters	<ul style="list-style-type: none"> The power rating between motor and inverter is too different Improper setting of motor parameters 	<ul style="list-style-type: none"> Select an inverter with suitable power rating Please set correct value of motor parameters (F08.00 - F08.04, F13.01 - F13.05)
E0024	Fault of external equipment	<ul style="list-style-type: none"> Fault terminal of external equipment operates 	<ul style="list-style-type: none"> Please check external equipment
E0025	PID reference loss	<ul style="list-style-type: none"> Analogue reference signal is smaller than F20.12 Analogue input circuit fault 	<ul style="list-style-type: none"> Please check the connection Please seek technical support
E0026	PID feedback loss	<ul style="list-style-type: none"> Analogue setting signal is smaller than F20.14 Analogue input circuit fault 	<ul style="list-style-type: none"> Please check the connection Please seek technical support
E0027	PID feedback out of limiting	<ul style="list-style-type: none"> Analogue setting signal is bigger than F20.16 Analogue input circuit fault 	<ul style="list-style-type: none"> Please check the connection Please seek technical support
E0028	SCI communication time-out	<ul style="list-style-type: none"> Connection fault of Communication cable Disconnected or not well connected 	<ul style="list-style-type: none"> Please check the connection

Note: E0022 not affect normal running.

Fault		Fault reasons	Counter-measures
E0029	SCI communication error	<ul style="list-style-type: none"> • Connection fault of Communication cable • Disconnected or not well connected • Communication setting error • Communication data error 	<ul style="list-style-type: none"> • Please check the connection • Please check the connection • Please correctly set the communication format (F17.00) and the baud rate (F17.01) • Send the data according to MODBUS protocol

7.2 Maintenance

Factors such as ambient temperature, humidity, PH, dust, oscillation, internal component aging, wear and tear will give rise to the occurrence of potential faults. Therefore, it is necessary to conduct daily maintenance to the controller.

- If HD30 has been transported for a long distance, check whether the components of HD30 are complete and the screws are well tightened.
- Periodically clean the dust inside HD30 and check whether the screws are loose.



Danger

- Only a trained and qualified professional person can maintain the controller.
- Maintenance personnel should take off all metal jewellery before carrying out maintenance or internal measurements in the controller. Suitable clothes and tools must be used.
- High voltage exists when the controller is powered up or running.
- Checking and maintaining can only be done after AC power of HD30 is cut off and wait for at least 10 minutes. The cover maintenance can only be done after ensured that the charge indicator inside HD30 and the indicators on the keypad are off and the voltage between power terminals (+) and (-) is below 36V.



Warning

- For HD30 with more than 2 years storage, please use voltage regulator to increase the input voltage gradually.
- Do not leave metal parts like screws or pads inside HD30.
- Do not make modification on the inside of controller without instruction from the supplier.
- There are IC components inside the controller, which are sensitive to stationary electricity. Directly touch the components on the PCB board is forbidden.

Daily Maintenance

HD30 must be operated in the specified environment (refer to section 3.2, page 13). Besides, some unexpected accidents may occur during running.

Therefore maintain it according to the Table 7-2. To prolong the lifetime of HD30, keep good running environment, record the daily run data and detect any abnormal behavior.

Table 7-2 Daily checking items

Items	Content	Criteria
Running environment	Temperature and humidity	-10 - +40°C, derating at 40 - 50°C Less than 95%RH, non-condensing
	Dust and water dripping	No conductive dust accumulating, no water dripping
	Gas	No strange smell
HD30	Oscillation and heating	Stable oscillation and proper temperature
	Noise	No abnormal sound
Motor	Heating	No overheat
	Noise	Low and regular noise
Running status parameters	Output current	Within rated range
	Output voltage	Within rated range

Periodical Maintenance

Customer should check the inverter in short time or every 3 to 6 months according to the actual environment so as to avoid hidden problems and make sure the inverter runs well for a long time.

General Inspection:

- Check whether the screws of control terminals are loose. If so, tighten them with a screw driver;
- Check whether the main circuit terminals are properly connected; whether the copper bar and mains cables are overheated;
- Check whether the power cables and control cables are damaged, check especially for any wear on the cable tube;
- Check whether the insulating tapes around the cable lugs are stripped, and for signs of overheating near terminations;
- Clean the dust on PCBs and air ducts with a vacuum cleaner.

Note:

1. Dielectric strength test of the controller has already been conducted in the factory. Do not do the test again. Otherwise, the controller might be damaged.
2. If insulation test to the motor is necessary, it should be done after the input terminals U/V/W of motor have been detached from HD30. Otherwise, HD30 will be damaged.
3. For controllers that have been stored for a long time, they must be powered up every 2 years. When supplying AC power to the controller, use a voltage regulator to gradually raise the input voltage to rated input voltage at least 5 hours.

Replacing Damaged Parts

The components that are easily damaged are: cooling fan and electrolytic capacitors of filters. Their lifetime depends largely on their application environment and preservation. The users can decide the time when the components should be replaced according to their service time.

Easily damaged	Cooling fan	Electrolytic capacitors
Life	60,000 hours	50,000 hours
Possible cause of damages	Wear of the bearing, aging of the fan vanes	High ambient temperature, aging of electrolyte and large pulse current induced by rapid changing loads
Criteria	After the inverter is switched off, check if the abnormal conditions such as crack existing on fan vanes and other parts. When the inverter is switched on, check if inverter running is normal, and check if there is any abnormal oscillation	Check if frequent overcurrent or overvoltage failures occur during inverter start-up with load. Check if there is any leakage of liquids. Check if the safety valve protrudes. Measure the static capacitance and insulation resistance

Unwanted Inverter Recycling

When disposing the inverter, please pay attention to the following factors:

- The capacitors may explode if they are burnt.
- Poisonous gas may be generated when the plastic parts like front covers are burnt.
- Disposing method: Please dispose unwanted inverters as industrial waste.

Chapter 8 Options

8.1 HD30-EIO

HD30 series inverters using with HD30-EIO can achieve the extension of analogue input, digital input and relay contact output.

Terminal Description

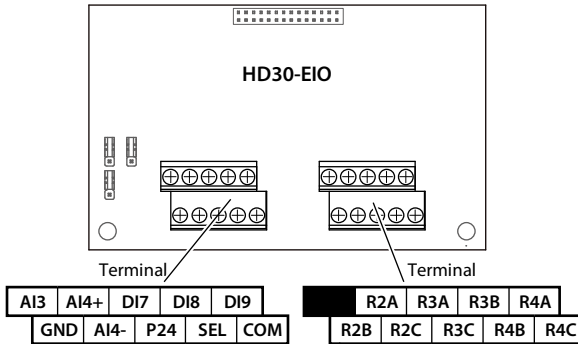

Figure 8-1 HD30-EIO terminal

Table 8-1 Terminal description

Terminal	Description	
AI3	Analogue input	Input voltage / current are selectable <ul style="list-style-type: none"> Input voltage range: -10 - 10V (input impedance 32kΩ) Input current range: 0 - 20mA (input impedance 500Ω)
AI4+	Analogue differential input	Input voltage / current are selectable <ul style="list-style-type: none"> Input voltage range: -10 - 10V (input impedance 34kΩ) Input current range: 0 - 20mA (input impedance 500Ω)
AI4-		
GND	Analogue ground	GND is isolated to COM
DI7 - DI9	Digital input	Programmable bipolar optional input signal <ul style="list-style-type: none"> Input voltage 0 - 30VDC (input impedance 4.7kΩ)
P24, COM	Digital power supply	Digital input use +24V as supply, max. output current is 200mA
SEL	Digital input common terminal	SEL and P24 are connected by default (factory setting) <ul style="list-style-type: none"> Disconnected SEL and P24 when use external power to drive DI
R2A/R2B/R2C R3A/R3B/R3C R4A/R4B/R4C	Relay output	Programmable output, contact rating: 250VAC/3A or 30VDC/1A <ul style="list-style-type: none"> RB,RC: normally closed; RA,RC: normally open

Note:

Limit the current within 3A if the relay terminal is to connect to AC 220V voltage signal.

Jumper

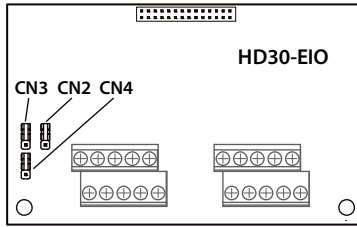

Figure 8-2 Jumper

Table 8-2 Jumper description

Jumper	Description
CN2 	AI3 analogue input channel can select voltage or current signal: <ul style="list-style-type: none"> Pin 1 & 2 are short-connected, AI3 inputs current signal. Pin 2 & 3 are short-connected, AI3 inputs voltage signal (factory setting).
CN3 	AI3 analogue input channel can select voltage or current signal: <ul style="list-style-type: none"> Pin 1 & 2 are short-connected, AI3 inputs current signal. Pin 2 & 3 are short-connected, AI3 inputs voltage signal (factory setting). <i>Note: Pin 2 & 3 of CN4 must be short-connected.</i>
CN4 	AI4 can select thermistor: <ul style="list-style-type: none"> Pin 1 & 2 are short-connected, AI4 is for the motor over-heating detection signal input via the external connected thermistor. Pin 2 & 3 are short-connected, AI4 is for the user reference analogue input (factory setting).

Terminal Wiring

Digital Input Connection (DI)

DI7 - DI9 have the same connection with control board digital input terminals (DI1 - DI6), please refer to section 4.4.4 Control Terminal Wiring.

Analogue Input Connection (AI)

AI3 with the AI2 of control terminal has same wiring, see analog input terminal of the section 4.4.4 Control Terminal Wiring, shown as Figure 4-8.

When AI4 is used as setting analogue input terminal, the connection is shown as Figure 8-3. (The AI4+ = analogue signal input)

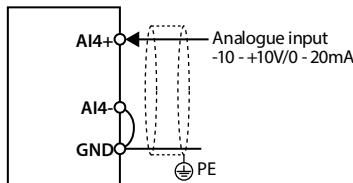

Figure 8-3 AI4 connection (AI4 = analogue input terminal)

When AI4 is used as motor overheating detection signal input terminal, the connection is shown as Figure 8-4. The motor stator coil built-in thermistor to access the analogue input and it should correctly set the jumper.

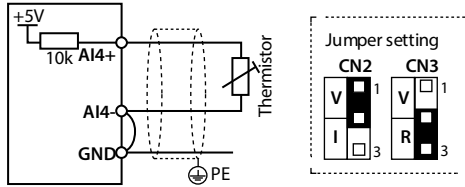

Figure 8-4 AI4 connection (AI4 = overheating detection signal input)

8.2 HD30-PIO

HD30 series inverters can use plastic interface card (HD30-PIO), HD30-PIO is specific development for injection molding machine industry, mainly provide two way isolated selectable sampling 0 - 24V voltage, 0 - 1A current signal analogue input channels.

Terminal Description

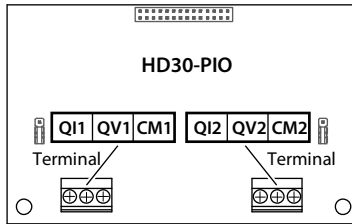

Figure 8-5 HD30-PIO terminal

Table 8-3 Terminal description

Terminal	Description		Reference function
Channel 1	Q1, CM1	Current input	Reference function AI3
	QV1, CM1	Voltage input	
Channel 2	Q2, CM2	Current input	Reference function AI4
	QV2, CM2	Voltage input	

Jumper

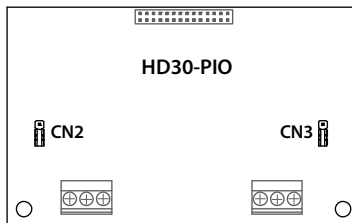

Figure 8-6 Jumper

Table 8-4 Jumper description

Jumper	Description
CN2 	Analogue input channel 1: • Pin 1 & 2 are short-connected, channel 1 inputs voltage signal (factory setting). • Pin 2 & 3 are short-connected, channel 1 inputs current signal.
CN3 	Analogue input channel 2: • Pin 1 & 2 are short-connected, channel 1 inputs voltage signal (factory setting). • Pin 2 & 3 are short-connected, channel 1 inputs current signal.

8.3 Keypad Installation Assembly

The keypad installation assembly includes mounting base and extension cable.

Mounting Base

The keypad mounting base is an accessory. If needed, please order goods.

Model: HD-KMB. The mounting base and its size are shown as Figure 8-7, the unit is mm.

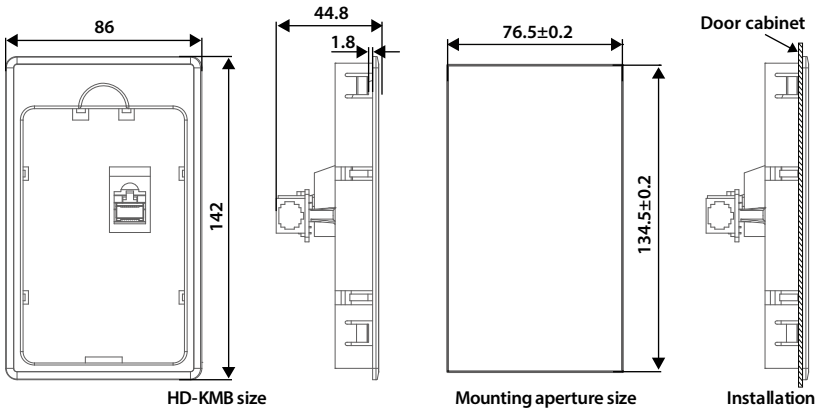

Figure 8-7 Mounting base and its size

Extension Cable

The keypad extension cable is an accessory. If needed, please order goods.

The models are as follows:

- 1m extension cable to keypad: HD-CAB-1M
- 2m extension cable to keypad: HD-CAB-2M
- 3m extension cable to keypad: HD-CAB-3M
- 6m extension cable to keypad: HD-CAB-6M

8.4 Power Regenerative Unit

Please refer to “HDRU Series Power Regenerative Unit User Manual” for more details.

8.5 Braking Unit and Braking Resistor

The braking unit has 2 models: HDBU-4T150 (the max. braking current is 150A) and HDBU-4T250 (the max. braking current is 250A). If needed, please order goods. Refer to the “HDBU Series Dynamic Braking Unit User Manual” for more details.

The braking unit and braking resistor selection is shown as Table 8-5.

The connection of braking unit and the braking resistor is shown as section 4.3.2 of Power Terminal Wiring (page 29).

Table 8-5 The braking unit and braking resistor selection

Model	Motor (kW)	Braking unit	Braking resistor			
			Lift load		Non-lift load	
			Min. Resistance	Min. power	Resistance	Min. power
Single/three phase: 200 - 240V, 50/60Hz						
HD30-2D0P4G	0.4 kW	Built-in	100 Ω	150 W	200 - 300 Ω	50 W
HD30-2D0P7G	0.75 kW	Built-in	80 Ω	300 W	150 - 250 Ω	100 W
HD30-2D1P5G	1.5 kW	Built-in	60 Ω	600 W	100 - 150 Ω	200 W
HD30-2D2P2G	2.2 kW	Built-in	40 Ω	750 W	80 - 100 Ω	250 W
HD30-2D3P7G	3.7 kW	Built-in	30 Ω	1.2 kW	60 - 80 Ω	400 W
HD30-2D5P5G	5.5 kW	Built-in	25 Ω	1.8 kW	40 - 50 Ω	600 W
HD30-2D7P5G	7.5 kW	Built-in	15 Ω	2.4 kW	30 - 40 Ω	800 W
HD30-2D011G	11 kW	Build-in selection	12 Ω	3.6 kW	20 - 25 Ω	1.2 kW
HD30-2D015G	15 kW	Build-in selection	10 Ω	4.5 kW	15 - 20 Ω	1.5 kW
Three phase: 200 - 240V, 50/60Hz						
HD30-2T018G	18.5 kW	Build-in selection	8 Ω	6 kW	10 - 15 Ω	2 kW
HD30-2T022G	22 kW	Build-in selection	7 Ω	7.5 kW	10 - 15 Ω	2.5 kW
HD30-2T030G	30 kW	Build-in selection	6 Ω	9 kW	8 - 10 Ω	3 kW
HD30-2T037G	37 kW	Build-in selection	5 Ω	12 kW	6 - 8 Ω	4 kW
HD30-2T045G	45 kW	HDBU-4T150	4 Ω	13.5 kW	4 - 6 Ω	4.5 kW
HD30-2T055G	55 kW	HDBU-4T150	4 Ω	16.5 kW	4 - 6 Ω	5.5 kW
HD30-2T075G	75 kW	HDBU-4T250	4 Ω	22.5 kW	4 - 6 Ω	7.5 kW
Three phase: 380 - 460V, 50/60Hz						
HD30-4T0P7G	0.75 kW	Built-in	150 Ω	300 W	250 - 350 Ω	100 W
HD30-4T1P5G	1.5 kW	Built-in	120 Ω	600 W	200 - 300 Ω	200 W
HD30-4T2P2G	2.2 kW	Built-in	100 Ω	750 W	150 - 250 Ω	250 W
HD30-4T3P7G/5P5P	3.7/5.5 kW	Built-in	80 Ω	1.2 kW	100 - 150 Ω	400 W
HD30-4T5P5G/7P5P	5.5/7.5 kW	Built-in	60 Ω	1.8 kW	80 - 100 Ω	600 W
HD30-4T7P5G/011P	7.5/11 kW	Built-in	45 Ω	2.4 kW	60 - 80 Ω	800 W
HD30-4T011G/015P	11/15 kW	Built-in	40 Ω	3.6 kW	40 - 50 Ω	1.2 kW
HD30-4T015G/018P	15/18.5 kW	Built-in	25 Ω	4.5 kW	30 - 40 Ω	1.5 kW
HD30-4T018G/022P	18.5/22 kW	Built-in	20 Ω	6 kW	25 - 30 Ω	2 kW
HD30-4T022G/030P	22/30 kW	Build-in selection	18 Ω	7.5 kW	20 - 25 Ω	2.5 kW

Model	Motor (kW)	Braking unit	Braking resistor			
			Lift load		Non-lift load	
			Min. Resistance	Min. power	Resistance	Min. power
HD30-4T030G/037P	30/37 kW	Build-in selection	15 Ω	9 kW	15 - 20 Ω	3 kW
HD30-4T037G/045P	37/45 kW	Build-in selection	12 Ω	12 kW	15 - 20 Ω	4 kW
HD30-4T045G/055P	45/55 kW	Build-in selection	10 Ω	13.5 kW	10 - 15 Ω	4.5 kW
HD30-4T055G/075P	55/75 kW	Build-in selection	9 Ω	16.5 kW	10 - 15 Ω	5.5 kW
HD30-4T075G/090P	75/90 kW	HDBU-4T150	6 Ω	22.5 kW	8 - 10 Ω	7.5 kW
HD30-4T090G/110P	90/110 kW	HDBU-4T150	6 Ω	27 kW	8 - 10 Ω	9 kW
HD30-4T110G/132P	110/132 kW	HDBU-4T150	6 Ω	33 kW	6 - 8 Ω	11 kW
HD30-4T132G/160P HD30-4T132G/160P-C	132/160 kW	HDBU-4T250	4 Ω	40 kW	6 - 8 Ω	13.2 kW
HD30-4T160G/200P HD30-4T160G/200P-C	160/200 kW	HDBU-4T250	4 Ω	48 kW	4 - 6 Ω	16 kW
HD30-4T200G/220P HD30-4T200G/220P-C	200/220 kW	HDBU-4T250	4 Ω	60 kW	4 - 6 Ω	20 kW
HD30-4T220G/250P HD30-4T220G/250P-C	220/250 kW	HDBU-4T250 *2	4 Ω *2	33kW*2	6 - 8 Ω *2	11kW *2
HD30-4T250G/280P HD30-4T250G/280P-C	250/280 kW	HDBU-4T250 *2	4 Ω *2	37.5kW*2	6 - 8 Ω *2	12.5kW *2
HD30-4T280G/315P HD30-4T280G/315P-C	280/315 kW	HDBU-4T250 *2	4 Ω *2	42kW*2	4 - 6 Ω *2	14kW *2
HD30-4T315G/355P HD30-4T315G/355P-C	315/355 kW	HDBU-4T250 *2	4 Ω *2	48kW*2	4 - 6 Ω *2	16kW *2
HD30-4T355G/400P HD30-4T355G/400P-C	355/400 kW	HDBU-4T250 *3	4 Ω *3	33kW*3	4 - 6 Ω *3	11kW *3
HD30-4T400G/450P HD30-4T400G/450P-C	400/450 kW	HDBU-4T250 *3	4 Ω *3	42kW*3	4 - 6 Ω *3	14kW *3
HD30-4T450G/500P HD30-4T450G/500P-C	450/500 kW	HDBU-4T250 *3	4 Ω *3	45kW*3	4 - 6 Ω *3	15kW *3
HD30-4T500G	500 kW	HDBU-4T250 *4	4Ω	39kW *4	4 - 6 Ω *4	12.5kW *4
HD30-4T560G	560 kW	HDBU-4T250 *4	4Ω	43kW *4	4 - 6 Ω *4	14kW *4
HD30-4T630G	630 kW	HDBU-4T250 *5	4Ω	39kW *5	4 - 6 Ω *5	12.5kW *5

Three phase: 500 - 690V, 50/60Hz

HD30-6T018G	18.5 kW	HDBU-6T150	10Ω	4.5kW	80 - 100 Ω	1.5kW
HD30-6T022G	22 kW	HDBU-6T150	10Ω	6kW	70 - 80 Ω	2kW
HD30-6T030G	30 kW	HDBU-6T150	10Ω	9kW	50 - 60 Ω	3kW
HD30-6T037G	37 kW	HDBU-6T150	10Ω	10.5kW	40 - 50 Ω	3.5kW
HD30-6T045G	45 kW	HDBU-6T150	10Ω	13.5kW	35 - 40 Ω	4.5kW
HD30-6T055G	55 kW	HDBU-6T150	10Ω	16.5kW	30 - 35 Ω	5.5kW
HD30-6T075G	75 kW	HDBU-6T150	10Ω	22.5kW	20 - 25 Ω	7.5kW
HD30-6T090G	90 kW	HDBU-6T150	10Ω	27kW	15 - 20 Ω	9kW

Model	Motor (kW)	Braking unit	Braking resistor			
			Lift load		Non-lift load	
			Min. Resistance	Min. power	Resistance	Min. power
HD30-6T110G	110 kW	HDBU-6T150	10Ω	33kW	15 - 20 Ω	11kW
HD30-6T132G	132 kW	HDBU-6T250	6Ω	39kW	10 - 15 Ω	13kW
HD30-6T160G	160 kW	HDBU-6T250	6Ω	48kW	8 - 10 Ω	16kW
HD30-6T200G	200 kW	HDBU-6T250	6Ω	60kW	8 - 10 Ω	20kW
HD30-6T220G	220 kW	HDBU-6T250	6Ω	66kW	8 - 10 Ω	22kW
HD30-6T250G	250 kW	HDBU-6T250 *2	6Ω*2	39kW *2	10 - 15 Ω*2	13kW *2
HD30-6T280G	280 kW	HDBU-6T250 *2	6Ω*2	39kW *2	10 - 15 Ω*2	13kW *2
HD30-6T315G	315 kW	HDBU-6T250 *2	6Ω*2	48kW *2	8 - 10 Ω*2	16kW *2
HD30-6T355G	355 kW	HDBU-6T250 *2	6Ω*2	60kW *2	8 - 10 Ω*2	20kW *2
HD30-6T400G	400 kW	HDBU-6T250 *2	6Ω*2	60kW *2	8 - 10 Ω*2	20kW *2

Note: *2, *3, *4, *5 means 2, 3, 4, 5 parallel modes.

Note:

- Please select braking resistor based on the above table.
Bigger resistor can protect the braking system in fault condition, but oversized resistor may bring a capacity decrease, lead to over voltage protection.
- The braking resistor should be mounted in a ventilated metal housing to prevent inadvertent contact during it works, for the temperature is high.

8.6 Reactor Selection

The reactor selections are shown as Table 8-6 and Table 8-7.

Table 8-6 AC reactor selection

Model	AC input reactor		AC output reactor	
	Model	Parameter (mH-A)	Model	Parameter (mH-A)
HD30-4T037G/045P	HD-AIL-4T037	0.19/75	HD-AOL-4T037	0.08/80
HD30-4T045G/055P	HD-AIL-4T045	0.16/90	HD-AOL-4T045	0.06/100
HD30-4T055G/075P	HD-AIL-4T055	0.13/115	HD-AOL-4T055	0.04/125
HD30-4T075G/090P	HD-AIL-4T075	0.093/150	HD-AOL-4T075	0.035/160
HD30-4T090G/110P	HD-AIL-4T090	0.08/180	HD-AOL-4T090	0.03/200
HD30-4T110G/132P	HD-AIL-4T110	0.067/210	HD-AOL-4T110	0.02/225
HD30-4T132G/160P HD30-4T132G/160P-C	HD-AIL-4T132	0.055/255	HD-AOL-4T132	0.016/280
HD30-4T160G/200P HD30-4T160G/200P-C	HD-AIL-4T160	0.046/305	HD-AOL-4T160	0.013/320
HD30-4T200G/220P HD30-4T200G/220P-C	HD-AIL-4T200	0.037/380	HD-AOL-4T200	0.011/400
HD30-4T220G/250P HD30-4T220G/250P-C	HD-AIL-4T220	0.034/415	HD-AOL-4T220	0.01/450
HD30-4T250G/280P HD30-4T250G/280P-C	HD-AIL-4T250	0.026/530	HD-AOL-4T250	0.009/560
HD30-4T280G/315P HD30-4T280G/315P-C	HD-AIL-4T280		HD-AOL-4T280	
HD30-4T315G/355P HD30-4T315G/355P-C	HD-AIL-4T315	0.023/600	HD-AOL-4T315	0.007/630
HD30-4T355G/400P HD30-4T355G/400P-C	HD-AIL-4T355	0.019/760	HD-AOL-4T355	0.006/800
HD30-4T400G/450P HD30-4T400G/450P-C	HD-AIL-4T400		HD-AOL-4T400	
HD30-4T450G/500P HD30-4T450G/500P-C	HD-AIL-4T450	0.017/850	HD-AOL-4T450	0.005/880
HD30-4T500G	Bild-in	-	Bild-in	-
HD30-4T560G	Bild-in	-	Bild-in	-
HD30-4T630G	Bild-in	-	Bild-in	-

Table 8-7 DC reactor selection

Model	DC reactor	
	Model	Parameter (mH-A)
HD30-4T037G/045P	HD-DCL-4T037	0.35/100
HD30-4T045G/055P	HD-DCL-4T045	0.29/120
HD30-4T055G/075P	HD-DCL-4T055	0.23/150
HD30-4T075G/090P	HD-DCL-4T075	0.17/200
HD30-4T090G/110P	HD-DCL-4T090	0.14/240
HD30-4T110G/132P	HD-DCL-4T110	0.12/290
HD30-4T132G/160P HD30-4T132G/160P-C	HD-DCL-4T132	0.11/330
HD30-4T160G/200P HD30-4T160G/200P-C	HD-DCL-4T160	0.09/400
HD30-4T200G/220P HD30-4T200G/220P-C	HD-DCL-4T200	0.07/500
HD30-4T220G/250P HD30-4T220G/250P-C	HD-DCL-4T220	0.06/550
HD30-4T250G/280P HD30-4T250G/280P-C	HD-DCL-4T250	0.05/700
HD30-4T280G/315P HD30-4T280G/315P-C	HD-DCL-4T280	
HD30-4T315G/355P HD30-4T315G/355P-C	Bild-in	-
HD30-4T355G/400P HD30-4T355G/400P-C	Bild-in	-
HD30-4T400G/450P HD30-4T400G/450P-C	Bild-in	-
HD30-4T450G/500P HD30-4T450G/500P-C	Bild-in	

Appendix A Quick Start for User Menu of Group U

User menu of Group U

Map the applied parameters to the U Group, only the U Group needs to be operated, you can achieve direct read and write the parameters.

When the function parameters are used less, but the position in the function menu is scattered, you can map the used function parameters to the U Group. This avoids the frequent switching of functional parameters, but also in accordance with their own habits to arrange the menu order, easy to remember and operate.

Note:

1. You must modify the U Group by setting the tens of the parameter F01.01 to 0 (do not lock the mapping relationship between U Group and F Group).
2. The factory default is 1 (lock the mapping relationship of U Group and F Group parameters).
3. You can use M button to quickly switch to the U Group menu by setting the function code F00.12 = 3.

Example for use

If you want to map F00.13 to the user menu map 1 (U00.00) and F03.01 to the user menu map 2 (U00.02), you only need to set U00.00 and U00.02 but do not set the mapping setting value (U00.01 and U00.03), as following table.

Which, two digits of setting value before the decimal point represent the functional Group number of Group F, and the other two digits after the decimal point represent the inter Group number.

Ref. Code	Function	Setting	Range
U00.00	User menu map of setting 1	00.13	00.00 - 23.03, 99.99 [Factory setting] If set as 99.99, there is no parameter map function
U00.02	User menu map of setting 2	03.01	
U00.01	The setting value of map 1	Without setting	
U00.03	The setting value of map 2	Without setting	

After finish setting, modifying the setting value of map (U00.01 and U00.03) can change value of F00.13 and F03.01 automatically.

Factory setting

The user menu Group U can set up to 16 parameters, of which there are 14 parameters have been set.

Ref. Code	Setting	Ref. Code	Setting
U00.00	00.01 (control mode selection)	U00.14	03.01 (Acc. time 1)
U00.02	00.06 (inverter max. output frequency)	U00.16	03.02 (Dec. time 1)
U00.04	00.08 (upper limit of operation frequency)	U00.18	08.00 (motor rated power)
U00.06	00.13 (starting frequency digital setting)	U00.20	08.01 (motor rated voltage)
U00.08	00.10 (frequency setting sources selection)	U00.22	08.02 (motor rated current)
U00.10	00.11 (command setting source selection)	U00.24	08.03 (motor rated frequency)
U00.12	02.13 (stop mode selection)	U00.26	08.04 (motor rated RPM)

A

Appendix B Parameters

Attributes are changed:

"*": It denotes that the value of this parameter is the actual value which cannot be modified.

"x": It denotes that the setting of this parameter cannot be modified when the inverter is in run status.

"o": It denotes that the setting of this parameter can be modified when the inverter is in run status.

"-": The same as the mapping functional parameter.

Ref. Code	Function	Setting Range	Default	Unit	Attribute	Setting
d00: Status Display Parameters (pages 54 - 57)						
d00.00	Series of the inverter	0x10 - 0x50			*	
d00.01	Software version of the control board	00.00 - 99.99			*	
d00.03	Special software version of the control board	00.00 - 99.99			*	
d00.05	Software version of the keypad	00.00 - 99.99			*	
d00.06	Custom series No.	0 - 9999			*	
d00.07	Motor and control mode	Unit: Display the current driving motor 0: Motor 1 1: Motor 2 Ten: Control mode 0: V/f control without PG 2: Vector control without PG			*	
d00.08	Rated current of the inverter	5.5kW or below type: 0.01A 7.5kW or above type: 0.1A			*	
d00.10	Inverter status	Unit: Bit0: Inverter fault Bit1: Run / stop Bit2: Forward / reverse Bit3: Zero speed running Ten: Bit1&Bit0: Acc. / Dec. / constant Bit3: DC braking (including start and stop DC braking) Hundred: Bit0: Parameter auto-tuning Bit2: Speed limiting value Bit3: Control mode Thousand: Bit0: Stall overvoltage Bit1: Current limiting			*	

Ref. Code	Function	Setting Range	Default	Unit	Attribute	Setting
d00.11	Master setting frequency source	0 - 13			*	
d00.12	Master setting frequency	0.01 - 400.00Hz			*	
d00.13	Auxiliary setting frequency	0.01 - 400.00Hz			*	
d00.14	Setting frequency	0.01 - 400.00Hz			*	
d00.15	Reference frequency (after Acc. / Dec.)	0.01 - 400.00Hz			*	
d00.16	Output frequency	0.01 - 400.00Hz			*	
d00.17	Setting speed	0 - 60000rpm			*	
d00.18	Running speed	0 - 60000rpm			*	
d00.20	Output voltage	0 - 999V			*	
d00.21	Output current	Actual value, unit is 0.1A			*	
d00.22	Torque given	-250.0 - 250.0% (motor rated torque)			*	
d00.23	Output torque	0 - 300.0% (motor rated torque)			*	
d00.24	Output power	Actual value, unit is 0.1kW			*	
d00.25	DC bus voltage	0 - 999V			*	
d00.26	Potentiometer input voltage of the keypad	0.00 - 5.00V			*	
d00.27	A11 input voltage	0.00 - 10.00V			*	
d00.28	A11 input voltage (after disposal)	0.00 - 10.00V			*	
d00.29	A12 input voltage	-10.00 - 10.00V			*	
d00.30	A12 input voltage (after disposal)	-10.00 - 10.00V			*	
d00.31	A13 input voltage	-10.00 - 10.00V			*	
d00.32	A13 input voltage (after disposal)	-10.00 - 10.00V			*	
d00.33	A14 input voltage	-10.00 - 10.00V			*	
d00.34	A14 input voltage (after disposal)	-10.00 - 10.00V			*	
d00.35	D16 terminal pulse input frequency	0 - 50000Hz			*	
d00.36	AO1 output	0.00 - 10.00V			*	
d00.37	AO2 output	0.00 - 10.00V			*	
d00.38	High-speed output pulse frequency	0 - 50000Hz			*	
d00.39	Heatsink temperature	0.0 - 999.9°C			*	
d00.40	Setting line speed	0 - max output line speed			*	
d00.41	Reference line speed	0 - max output line speed			*	
d00.44	Process PID reference	-100.0 - 100.0%			*	
d00.45	Process PID feedback	-100.0 - 100.0%			*	
d00.46	Process PID tolerance	-100.0 - 100.0%			*	

Ref. Code	Function	Setting Range	Default	Unit	Attribute	Setting
d00.47	Process PID integral item	-100.0 - 100.0%			*	
d00.48	Process PID output	-100.0 - 100.0%			*	
d00.49	External counting value	0 - 9999			*	
d00.50	Input terminal status	Bit0 - Bit8 corresponding to DI1 - DI9 0: Input terminal disconnect with common terminal 1: Input terminal connect with common terminal <i>Only using HD30-EIO can the DI7 - DI9 be enabled</i>			*	
d00.51	Output terminal status	Bit0 - Bit1 corresponding to DO1 - DO2 Bit2 - Bit5 corresponding to RLY1 - RLY4 0: Output terminal disconnect with common terminal 1: Output terminal connect with common terminal <i>Only using HD30-EIO can the RLY2 - RLY4 be enabled</i>			*	
d00.52	MODBUS communication status	0: Normal 1: Communication timeout 2: Incorrect data frame head 3: Incorrect data frame checking 4: Incorrect data frame content			*	
d00.53	Actual length	0 - 65535m			*	
d00.54	Total length	0 - 65535km			*	
d00.55	Total time at power-on	0 - 65535h			*	
d00.56	Total time at operation	0 - 65535h			*	
d00.57	High bit of motor total energy consumption	0 - 65535k kW.h			*	
d00.58	Low bit of motor total energy consumption	0.0 - 999.9kW.h			*	
d00.59	High bit of energy con. at this time running	0 - 65535k kW.h			*	
d00.60	Low bit of energy con. at this time running	0.0 - 999.9kW.h			*	
d00.61	Present fault	1 - 100 <i>100: Means undervoltage</i>			*	
F00: Basic Parameter (pages 57 - 60)						
F00.00	Control mode selection	0: Speed control 1: Torque control	0	1	×	
F00.01	Motor 1 control mode selection	0: V/f control without PG 2: Vector control without PG	0	1	×	

Ref. Code	Function	Setting Range	Default	Unit	Attribute	Setting
F00.02	Inverter type setting	0: G type 1: P type	0	1	×	
F00.03	Motor selection	0: Motor 1 1: Motor 2	0	1	×	
F00.04	HD30 general extension option selection	0: Option is invalid 1: HD30-EIO is valid 3: HD30-PIO is valid	0	1	×	
F00.06	Inverter max. output frequency	50.00 - 400.00Hz	50.00Hz	0.01Hz	×	
F00.07	Upper limit of operation frequency setting source	0: Digital setting (F00.08) 1: Analogue input AI setting 2: Terminal pulse setting 3 - 6: AI1 - AI4 set 7: Keypad potentiometer setting	0	1	×	
F00.08	Upper limit of operation frequency	0.00 - F00.06	50.00Hz	0.01Hz	×	
F00.09	Lower limit of operation frequency	0.00 - upper limit	0.00Hz	0.01Hz	×	
F00.10	Frequency setting sources selection	0: Display panel digital setting 1: Terminal digital setting 2: SCI communication setting 3: AI analogue setting 4: Terminal pulse setting 6 - 9: AI1 - AI4 set 10: Keypad potentiometer setting	0	1	○	
F00.11	Command setting source selection	0: Display panel running source 1: Terminal running source 2: SCI communication running source	0	1	×	
F00.12	Function selection of the multi-function key	0: Switch the keypad running direction 1: Switch local and remote control 2: Multi-function key is invalid 3: U group shortcut menu	2	1	○	
F00.13	Starting frequency digital setting	0.00 - upper limit	50.00Hz	0.01Hz	○	
F00.14	Frequency setting control	Unit: Frequency setting save selection at power outage 0: Not stored when power down 1: Storage when power down	1001	1	○	

Ref. Code	Function	Setting Range	Default	Unit	Attribute	Setting
F00.14	Frequency setting control	Ten: Frequency setting control selection at stop 0: Set frequency at stop 1: Set the frequency to F00.13 when stopping Hundred: Communication setting frequency storage selection 0: Not stored when power down 1: Storage when power down Thousand: Switch the frequency channel to the analogue selection 0: Not saved 1: Save	1001	1	○	
F00.15	Jog operation frequency digital setting 1	0.00 - upper limit	5.00Hz	0.01Hz	○	
F00.16	Interval of jog operation	0.0 - 100.0s	0.0s	0.1s	×	
F00.17	Operation direction selection	0: The same as run command 1: Opposite to run command	0	1	×	
F00.18	Anti-reverse operation	0: Reverse operation is permitted 1: Reverse operation is prohibited	0	1	×	
F00.19	Dead time of direction switch	0.0 - 3600.0s	0.0s	0.1s	×	
F00.20	Key enable of optional keypad	0: Enabled 1: Disabled	0	1	○	
F00.21	Dormant function selection	0: Disabled 1: Enabled	0	1	×	
F00.22	Dormancy wake up time	0.0 - 6000.0s	1.0s	0.1s	○	
F00.24	Sleep delay time	0.0 - 6000.0s	1.0s	0.1s	○	
F00.25	Sleep frequency	0.00Hz - upper limit	0.00Hz	0.01Hz	○	
F00.26	Action selection for inverter running at zero frequency	Unit: When running is controlled by V/f, action selection of zero frequency 0: No treatment 1: Inverter lock output 2: Inverter run in DC brake Ten: Zero frequency action selection in open loop vector running Hundred: Zero frequency action selection in torque control 0: No treatment	111	1	×	

Ref. Code	Function	Setting Range	Default	Unit	Attribute	Setting
		1: Inverter lock output 2: Inverter run in DC brake 3: The frequency converter is operated by pre-excitation				
F00.27	Command source binding frequency source selection	Unit: Panel command binding frequency source selection Ten: Terminal command Binding frequency source selection Hundred: Communication command binding frequency source selection 0: No binding 1: Keypa digital setting 2: Terminal digital setting 3: SCI communicaiton setting 5: Terminal pulse setting 7 - 9: AI1 - AI3 setting A: AI4 setting b: Keypad potentiometer setting C: PIDsetting d: Multi-speed setting			×	
F00.28	Functions selection of button STOP	0: Only valid in control of keypad 1: Valid in all control mode	0	1	○	
F01: Protection of Parameters (refer to pages 60 - 63)						
F01.00	User's password	00000 - 65535	0	1	○	
F01.01	Menu mode selection	Unit: 0: Full menu mode 1: Checking menu mode (Only different from factory setting parameters can be displayed) Ten: 0: Does not lock the parameter mapping relationship of Group U and Group F 1: Lock the parameter mapping relationship of Group U and Group F Hundred: 0: After password protection, Group F and U parameters can be read 1: After password protection, Group F and U parameters are prohibited from reading	010	1	○	



Ref. Code	Function	Setting Range	Default	Unit	Attribute	Setting
F01.02	Function code parameter initialization	0: No operation 1: Restore to factory settings 2,3: Download the keypad EEPROM parameter 1/2 to the current function code settings 4: Clear fault information 5,6: Download the keypad EEPROM parameter 1/2 to the current function code settings (including the motor parameters)	0	1	×	
F01.03	Display panel EEPROM parameter initialization	0: No operation 1,2: Upload the current function code settings to the keypad EEPROM parameter 1/2	0	1	○	
F02: Run / Stop Control Parameters (pages 63 - 65)						
F02.00	Start mode selection	0: From the DWELL frequency to start 1: Brake first and then start from DWELL frequency 2: Start after speed tracking	0	1	×	
F02.01	Starting delay time	0.00 - 10.00s	0.00s	0.01s	×	
F02.02	Start DWELL frequency setting	0.00 - upper limit	0.00Hz	0.01Hz	×	
F02.03	Retention time of starting DWELL frequency	0.00 - 10.00s	0.00s	0.01s	×	
F02.04	DC braking current setting	0 - 100% (inverter's rated current)	50%	1%	×	
F02.05	DC braking time at start	0.00 - 60.00s	0.50s	0.01s	×	
F02.06	Faster tracking results compensation value	0.000 - 2.000Hz	0.000Hz	0.001Hz	○	
F02.13	Stop mode selection	0: Dec. to stop 1: Coast to stop 2: Dec. to stop with DC braking	0	1	×	
F02.14	DWELL frequency setting at stop	0.00 - upper limit	0.00Hz	0.01Hz	×	
F02.15	Retention time of DWELL frequency at stop	0.00 - 10.00s	0.00s	0.01s	×	
F02.16	DC braking initial frequency at stop	0.00 - 50.00Hz	0.50Hz	0.01Hz	×	
F02.17	DC braking waiting time at stop	0.00 - 10.00s	0.00s	0.01s	×	
F02.18	DC braking time at stop	0.00 - 10.00s	0.50s	0.01s	×	
F02.19	Jog control mode	Unit: 0: The jog functions of start and stop mode etc are invalid	10	1	×	

Ref. Code	Function	Setting Range	Default	Unit	Attribute	Setting
		1: The jog functions of start and stop mode etc are enabled Ten: 0: Terminal jog is not preferred 1: Terminal jog priority				
F02.20	Pre-excitation time	0.00 - 0.50s	0.50s	0.01s	×	
F03: Acc. / Dec. Parameters (pages 65 - 67)						
F03.00	Acc. / Dec. mode selection	Unit: Mode selection of Acc. and Dec. 0: Linear Acc. or Dec. 1: S-curve Acc. or Dec. Ten: Acc. / Dec. time reference frequency adjustment 0: Max. frequency (F00.06) 1: Set frequency	00	1	○	
F03.01	Acc. time 1	0.1 - 6000.0s	15kW or below: 10.0s 18.5 - 55 kW: 30.0s 75kW and above: 60.0s	0.1s	○	
F03.02	Dec. time 1	0.1 - 6000.0s		0.1s	○	
F03.03	Acc. time 2	0.1 - 6000.0s		0.1s	○	
F03.04	Dec. time 2	0.1 - 6000.0s		0.1s	○	
F03.05	Acc. time 3	0.1 - 6000.0s		0.1s	○	
F03.06	Dec. time 3	0.1 - 6000.0s		0.1s	○	
F03.07	Acc. time 4	0.1 - 6000.0s		0.1s	○	
F03.08	Dec. time 4	0.1 - 6000.0s		0.1s	○	
F03.09	Switching frequency of Acc. time 2 and time 1	0.00 - upper limit	0.00Hz	0.01Hz	×	
F03.10	Switching frequency of Dec. time 2 and time 1	0.00 - upper limit	0.00Hz	0.01Hz	×	
F03.11	S-curve characteristic time at starting Acc.	0.00 - 2.50s	0.20s	0.01s	○	
F03.12	S-curve characteristic time at ending Acc.	0.00 - 2.50s	0.20s	0.01s	○	
F03.13	S-curve characteristic time at starting Dec.	0.00 - 2.50s	0.20s	0.01s	○	
F03.14	S-curve characteristic time at ending Dec.	0.00 - 2.50s	0.20s	0.01s	○	
F03.15	Acc. time of jog operation	0.1 - 6000.0s	6.0s	0.1s	○	
F03.16	Dec. time of jog operation	0.1 - 6000.0s	6.0s	0.1s	○	
F03.17	Dec. time of emergency stop	0.1 - 6000.0s	10.0s	0.1s	○	
F04: Process PID Control (pages 67 - 70)						
F04.00	Process PID control selection	0: PID control is disabled 1: PID control is enabled	0	1	×	



Ref. Code	Function	Setting Range	Default	Unit	Attribute	Setting
F04.01	Reference source selection	0: Digital reference 1: AI analogue reference 2: Terminal pulse reference 3 - 6: AI1 - AI4 given 7: Operation panel potentiometer given	0	1	×	
F04.02	Feedback source selection	0: AI analogue feedback 1: Terminal pulse feedback 2 - 5: AI1 - AI4 given 6: Operation panel potentiometer given 7: Speedn closed loop feedback	0	1	×	
F04.03	Setting digital reference	-100.0 - 100.0%	0.00%	0.01%	○	
F04.04	Proportional gain (P1)	0.0 - 500.0	50.0	0.1	○	
F04.05	Integral time (I1)	0.01 - 10.00s	1.00s	0.01s	○	
F04.06	Integral upper limit	0.0 - 100.0%	100.0%	0.1%	○	
F04.07	Differential time (D1)	0.00 - 10.00s <i>0.00: The differential is disabled</i>	0.00s	0.01s	○	
F04.08	Differential amplitude limit value	0.00 - 100.0%	20.0%	0.1%	○	
F04.09	Sampling cycle (T)	0.01 - 50.00s	0.10s	0.01s	○	
F04.10	Bias limit	0.0 - 20.0% (reference)	0.0%	0.1%	○	
F04.11	PID regulator upper limit source selection	0: Set by F04.13 1: Set by AI analogue value 2: Set by terminal pulse input 3 - 6: AI1 - AI4 given 7: Keypad potentiometer setting	0	1	×	
F04.12	PID regulator lower limit source selection	0: Set by F04.14 1: Set by AI analogue value 2: Set by terminal pulse input 3 - 6: AI1 - AI4 given 7: Keypad potentiometer setting	0	1	×	
F04.13	PID regulator upper limit value	0.00 - upper limit	50.00Hz	0.01Hz	×	
F04.14	PID regulator lower limit value	0.00 - upper limit	0.00Hz	0.01Hz	×	
F04.15	PID regulator characteristic	0: Positive 1: Negative	0	1	×	
F04.17	PID output filter time	0.01 - 10.00s	0.05s	0.01s	○	
F04.18	PID output reverse selection	0: PID regulation disable reverse (When PID output is negative, 0 is the limit) 1: PID regulation enable reverse (When F00.18 = 1 disable reverse, 0 is the limit)	0		×	

Ref. Code	Function	Setting Range	Default	Unit	Attribute	Setting
F04.19	PID output reverse frequency's upper limit	0.00Hz - upper limit	50.00Hz	0.01Hz	×	
F04.20	Proportional gain (P2)	0.0 - 500.0	50.0	0.1	○	
F04.21	Integral time (I2)	0.01 - 10.00s	1.00s	0.01s	○	
F04.22	Derivative time (D2)	0.00 - 10.00s	0.00s	0.01s	○	
F04.23	PID parameter adjustment basis	0: Do not adjust 1: DI 2: Deviation 3: Frequency	0	1	○	
F04.24	PID parameter switching point 1	0.0% - F04.25	0.0%	0.1%	○	
F04.25	PID parameter switching point 2	F04.24 - 100.0%	100.0%	0.1%	○	
F04.27	Pulse of each turn	1 - 9999	1024	1	×	
F04.28	Max. closed loop speed	1 - 24000rpm	1500rpm	1rpm	×	
F04.29	PID arithmetic mode	0: No operation at stop 1: Operation at shutdown	0	1	×	
F04.30	PID sleep	0: No sleeping 1: Sleep enable	0	1	×	
F04.31	Tolerance of waking up	0.0 - 100.0%	0.0%	0.1%	○	
F04.32	Delay of waking up	0.0 - 6000.0s	10.0s	0.1s	○	
F04.33	Sleep tolerance	0.0 - 100.0%	0.0%	0.1%	○	
F04.34	Sleep delay	0.0 - 6000.0s	10.0s	0.1s	○	
F04.35	Sleep frequency	0.00Hz - max. frequency	20.00Hz	0.01Hz	○	
F05: External Reference Curve Parameters (pages 70 - 72)						
F05.00	External reference curve selection	Unit: AI1 characteristic curve selection Ten: AI2 characteristic curve selection Hundred: AI3 characteristic curve selection Thousand: AI4 characteristic curve selection Ten thousand: Pulse input characteristic curve selection 0: Line 1 1: Line 2 2: Polyline 3: No treatment <i>Only when using HD30-EIO can hundreds and thousands be enabled</i>	33333	1	×	
F05.01	Min. reference of line 1	0.0 - F05.03	0.0%	0.1%	○	

Ref. Code	Function	Setting Range	Default	Unit	Attribute	Setting
F05.02	Min. reference corresponding value of line 1	0.0 - 100.0%	0.0%	0.1%	○	
F05.03	Max. reference of line 1	F05.01 - 100.0%	100.0%	0.1%	○	
F05.04	Max. reference corresponding value of line 1	0.0 - 100.0%	100.0%	0.1%	○	
F05.05	Min. reference of line 2	0.0 - F05.07	0.0%	0.1%	○	
F05.06	Min. reference corresponding value of line 2	0.0 - 100.0%	0.0%	0.1%	○	
F05.07	Max. reference of line 2	F05.05 - 100.0%	100.0%	0.1%	○	
F05.08	Max. reference corresponding value of line 2	0.0 - 100.0%	100.0%	0.1%	○	
F05.09	Max. reference of polyline	F05.11 - 100.0%	100.0%	0.1%	○	
F05.10	Max. reference corresponding value of polyline	0.0 - 100.0%	100.0%	0.1%	○	
F05.11	Inflection point 2 reference of polyline	F05.13 - F05.09	100.0%	0.1%	○	
F05.12	Inflection point 2 corresponding value	0.0 - 100.0%	100.0%	0.1%	○	
F05.13	Inflection point 1 reference of polyline	F05.15 - F05.11	0.0%	0.1%	○	
F05.14	Inflection point 1 corresponding value	0.0 - 100.0%	0.0%	0.1%	○	
F05.15	Min. reference of polyline	0.0 - F05.13	0.0%	0.1%	○	
F05.16	Min. reference corresponding value of polyline	0.0 - 100.0%	0.0%	0.1%	○	
F05.17	Skip frequency 1	F00.09 - upper limit	0.00Hz	0.01Hz	○	
F05.18	Skip frequency 2	F00.09 - upper limit	0.00Hz	0.01Hz	○	
F05.19	Skip frequency 3	F00.09 - upper limit	0.00Hz	0.01Hz	○	
F05.20	Range of skip frequency	0.00 - 30.00Hz	0.00Hz	0.01Hz	○	
F05.21	Jog operation frequency digital setting 2	0.00 - upper limit	5.00Hz	0.01Hz	○	
F05.22	Operation panel potentiometer curve selection	0: Straight line 1 1: Straight line 2 2: Polyline 3: No treatment	3	1	×	
F06: MS SPEED and Simple PLC (pages 72 - 75)						
F06.00	Multi-step frequency command 1	F00.09 - upper limit	3.00Hz	0.01Hz	○	
F06.01	Multi-step frequency command 2	F00.09 - upper limit	6.00Hz	0.01Hz	○	
F06.02	Multi-step frequency command 3	F00.09 - upper limit	9.00Hz	0.01Hz	○	
F06.03	Multi-step frequency command 4	F00.09 - upper limit	12.00Hz	0.01Hz	○	

Ref. Code	Function	Setting Range	Default	Unit	Attribute	Setting
F06.04	Multi-step frequency command 5	F00.09 - upper limit	15.00Hz	0.01Hz	○	
F06.05	Multi-step frequency command 6	F00.09 - upper limit	18.00Hz	0.01Hz	○	
F06.06	Multi-step frequency command 7	F00.09 - upper limit	21.00Hz	0.01Hz	○	
F06.07	Multi-step frequency command 8	F00.09 - upper limit	24.00Hz	0.01Hz	○	
F06.08	Multi-step frequency command 9	F00.09 - upper limit	27.00Hz	0.01Hz	○	
F06.09	Multi-step frequency command 10	F00.09 - upper limit	30.00Hz	0.01Hz	○	
F06.10	Multi-step frequency command 11	F00.09 - upper limit	33.00Hz	0.01Hz	○	
F06.11	Multi-step frequency command 12	F00.09 - upper limit	36.00Hz	0.01Hz	○	
F06.12	Multi-step frequency command 13	F00.09 - upper limit	39.00Hz	0.01Hz	○	
F06.13	Multi-step frequency command 14	F00.09 - upper limit	42.00Hz	0.01Hz	○	
F06.14	Multi-step frequency command 15	F00.09 - upper limit	45.00Hz	0.01Hz	○	
F06.15	Simple PLC control selection	0: No PLC operation 1: Enabling PLC operation	0	1	×	
F06.16	Simple PLC operation mode selection	Unit: PLC operation mode selection 0: Stop after single cycle operation 1: Maintain the final value after single cycle of PLC operation 2: Cycle operation Ten: PLC operation restart mode selection after pause 0: Start from step 1 1: Continue to operate from the step where the inverter pauses 2: Continue to operate at the frequency when the inverter pauses Hundred: Save the PLC status after power failure 0: Not be saved 1: Saved	0000	1	×	

Ref. Code	Function	Setting Range	Default	Unit	Attribute	Setting	
F06.16	Simple PLC operation mode selection	Thousand: time unit selection of the PLC step 0: Second (s) 1: Minute (m)	0000	1	×		
F06.17	Setting of PLC step 1	Unit: PLC running frequency selection	000	1	○		
F06.19	Setting of PLC step 2		000	1	○		
F06.21	Setting of PLC step 3	0: Multi- step frequency command 1: Depend on F00.10	000	1	○		
F06.23	Setting of PLC step 4		000	1	○		
F06.25	Setting of PLC step 5	Ten: Operation direction selection of PLC at different step	000	1	○		
F06.27	Setting of PLC step 6		000	1	○		
F06.29	Setting of PLC step 7		0: Forward	000	1	○	
F06.31	Setting of PLC step 8		1: Reverse	000	1	○	
F06.33	Setting of PLC step 9		2: Depend on run command	000	1	○	
F06.35	Setting of PLC step 10	Hundred: Acc. / Dec. time selection of PLC at different steps	000	1	○		
F06.37	Setting of PLC step 11		0: Acc. / Dec. time 1	000	1	○	
F06.39	Setting of PLC step 12		1: Acc. / Dec. time 2	000	1	○	
F06.41	Setting of PLC step 13		2: Acc. / Dec. time 3	000	1	○	
F06.43	Setting of PLC step 14		3: Acc. / Dec. time 4	000	1	○	
F06.45	Setting of PLC step 15		000	1	○		
F06.18	Running time of step 1	0.0 - 3276.7	5.0	0.1	○		
F06.20	Running time of step 2	0.0 - 3276.7	0.0	0.1	○		
F06.22	Running time of step 3	0.0 - 3276.7	0.0	0.1	○		
F06.24	Running time of step 4	0.0 - 3276.7	0.0	0.1	○		
F06.26	Running time of step 5	0.0 - 3276.7	0.0	0.1	○		
F06.28	Running time of step 6	0.0 - 3276.7	0.0	0.1	○		
F06.30	Running time of step 7	0.0 - 3276.7	0.0	0.1	○		
F06.32	Running time of step 8	0.0 - 3276.7	0.0	0.1	○		
F06.34	Running time of step 9	0.0 - 3276.7	0.0	0.1	○		
F06.36	Running time of step 10	0.0 - 3276.7	0.0	0.1	○		
F06.38	Running time of step 11	0.0 - 3276.7	0.0	0.1	○		
F06.40	Running time of step 12	0.0 - 3276.7	0.0	0.1	○		
F06.42	Running time of step 13	0.0 - 3276.7	0.0	0.1	○		
F06.44	Running time of step 14	0.0 - 3276.7	0.0	0.1	○		
F06.46	Running time of step 15	0.0 - 3276.7	0.0	0.1	○		

Ref. Code	Function	Setting Range	Default	Unit	Attribute	Setting
F07: Wobble Operation Parameters (pages 75 - 76)						
F07.00	Wobble operation selection	0: Disabled 1: Enabled	0	1	×	
F07.01	Wobble operation mode	Unit: Start mode of wobble operation 0: Auto start (according to F07.03) 1: Manual start Ten: Wobble operation amplitude 0: Relative to the wobble central frequency 1: Relative to the max. output frequency Hundred: Restart mode of wobble operation 0: The inverter restarts the wobble operation as per the recorded frequency and direction when it stops last time 1: The inverter restarts the wobble operation from 0Hz Thousand: Save the wobble operation parameters at power outage 0: Saved 1: Not be saved	0000	1	×	
F07.02	Preset wobble frequency	0.00 - upper limit	0.00Hz	0.01Hz	×	
F07.03	Holding time of preset wobble frequency	0.0 - 999.9s	0.0s	0.1s	×	
F07.04	Wobble amplitude	0.0 - 50.0%	0.0%	0.1%	×	
F07.05	Jump frequency	0.0 - F07.04	0.0%	0.1%	×	
F07.06	Wobble operation cycle	0.0 - 999.9s	10.0s	0.1s	×	
F07.07	Rising time of triangle wave	0.0 - 100.0% (F07.06)	50.0%	0.1%	×	
F08: Asyn. Motor 1 Parameters (pages 76 - 78)						
F08.00	Rated power of motor 1	0.2 - 999.9kW	Depend on HD30	0.1kW	×	
F08.01	Rated voltage of motor 1	0 - inverter's rated voltage		1V	×	
F08.02	Rated current of motor 1	5.5kW above: 0.1 - 2500.0A 5.5kW or below: 0.01 - 250.00A		0.1A 0.01A	×	
F08.03	Rated frequency of motor 1	1.0 - 400.0Hz	50.0Hz	0.1Hz	×	
F08.04	Rated speed of motor 1	1 - 2400rpm	1500rpm	1rpm	×	
F08.05	Power factor of motor 1	0.001 - 1.000	Depend on HD30	0.001	×	

Ref. Code	Function	Setting Range	Default	Unit	Attribute	Setting			
F08.06	Parameter auto-tuning of motor 1	0: Auto-tuning is disabled 1: Stationary auto-tuning 2: Rotary auto-tuning 3: Motor stator resistance measurement	0	1	×				
F08.07	Stator resistance of motor 1	5.5kW below: 0.00 - 99.99Ω	Depend on HD30	0.01Ω	×				
		7.5 - 75kW: 0.000 - 9.999Ω		0.001Ω					
		90kW and above: 0.0000 - 0.9999Ω		0.0001Ω					
F08.08	Rotor resistance of motor 1	5.5kW below: 0.00 - 99.99Ω		0.01Ω	×				
		7.5 - 75kW: 0.000 - 9.999Ω		0.001Ω					
		90kW and above: 0.0000 - 0.9999Ω		0.0001Ω					
F08.09	Leakage inductance of motor 1	5.5kW below: 0.0 - 5000.0mH		Depend on HD30	0.1mH	×			
		7.5 - 75kW: 0.00 - 500.00mH			0.01mH				
		90kW and above: 0.000 - 50.000 mH			0.001 mH				
F08.10	Mutual inductance of motor 1	5.5kW below: 0.0 - 5000.0mH			Depend on HD30	0.1mH	×		
		7.5 - 75kW: 0.00 - 500.00mH	0.01mH						
		90kW and above: 0.000 - 50.000 mH	0.001 mH						
F08.11	Idling exciting current of motor 1	5.5kW and below: 0.0 - 999.9A	Depend on HD30			0.1A	×		
		5.5kW above: 0.00 - 99.99A				0.01A			
F08.12	Motor 1 core saturation coefficient 1	0.00 - 1.00				1.00	0.01	×	
F08.13	Motor 1 core saturation coefficient 2	0.00 - 1.00				1.00	0.01	×	
F08.14	Motor 1 core saturation coefficient 3	0.00 - 1.00		1.00		0.01	×		
F08.15	Motor 1 core saturation coefficient 4	0.00 - 1.00		1.00		0.01	×		
F08.16	Motor 1 core saturation coefficient 5	0.00 - 1.00		1.00		0.01	×		
F09: V/f Control Parameters (pages 78 - 80)									
F09.00	V/f curve selection of motor 1	0: Line 1: Square curve 2: 1.2 exponential curve 3: 1.7 exponential curve 4: User-defined curve		0	1	×			
F09.01	V/f frequency value F3 of motor 1	F09.03 - 100.0%		80.0%	0.1%	×			
F09.02	V/f voltage value V3 of motor 1	F09.04 - 100.0%	80.0%	0.1%	×				
F09.03	V/f frequency value F2 of motor 1	F09.05 - 100.0%	50.0%	0.1%	×				

Ref. Code	Function	Setting Range	Default	Unit	Attribute	Setting
F09.04	V/f voltage value V2 of motor 1	F09.06 - 100.0%	50.0%	0.1%	×	
F09.05	V/f frequency value F1 of motor 1	0.0% - F09.03	0.0%	0.1%	×	
F09.06	V/f voltage value V1 of motor 1	0.0% - F09.04	0.0%	0.1%	×	
F09.07	Torque boost of motor 1	0.0 - 30.0% 0.0: Auto torque boost	45kW and below: 2.0% 55 - 132kW: 1.0% 160kW and above: 0.5%	0.1%	×	
F09.08	Cut-off point used for manual torque boost of motor 1	0.0 - 50.0% (F08.03)	25.0%	0.1%	○	
F09.09	Slip compensation gain of motor 1	0.0 - 300.0%	00.0%	0.1%	○	
F09.10	Slip compensation filter time of motor 1	0.01 - 10.00s	0.10s	0.01s	○	
F09.11	Slip compensation limitation of motor 1	0.0 - 250.0%	200.0%	0.1%	×	
F09.12	Compensation constant of motor 1	0.1 - 25.0s	2.0s	0.1s	×	
F09.14	AVR function of motor 1	0: Disabled 1: Enabled all the time 2: Disabled in Dec. process	1	1	○	
F09.15	Motor 1 low frequency suppression shock coefficient	0 - 200	50	1	○	
F09.16	Motor 1 high frequency suppression shock coefficient	0 - 200	20	1	○	
F09.17	Motor 1 energy saving control select	0: Energy saving control invalid 3: Energy saving according to output current	0	1	×	
F09.18	Motor 1 energy saving factor	0.0 - 100.0%	5.0%	0.1%	○	
F09.19	Motor 1 energy start frequency	0.00 - 50.00Hz	25.00Hz	0.01Hz	○	
F09.20	Motor 1 energy switching point	0.0 - 100.0%	100.0%	0.1%	○	
F09.21	Motor 1 energy saving detecting times	0 - 5000 times	10 times	1 times	○	
F09.22	Motor 1 energy voltage recovery time	40 - 4000ms	100ms	1ms	○	

Ref. Code	Function	Setting Range	Default	Unit	Attribute	Setting
F09.23	Motor 1 energy voltage decreasing time	40 - 4000ms	100ms	1ms	○	
F10: Motor 1 Vector Control Speed-loop Parameters (pages 80 - 81)						
F10.00	Speed control proportional gain 1 of motor 1	0.1 - 200.0	10.0	0.1	○	
F10.01	Speed control integral time 1 of motor 1	0.00 - 10.00s	0.10s	0.01s	○	
F10.02	Speed control proportional gain 2 of motor 1	0.1 - 200.0	10.0	0.1	○	
F10.03	Speed control integral time 2 of motor 1	0.00 - 10.00s	0.20s	0.01s	○	
F10.04	Speed-loop PI switching frequency 1 of motor 1	0.00Hz - F10.05	10.00Hz	0.01Hz	○	
F10.05	Speed-loop PI switching frequency 2 of motor 1	F10.04 - 50.00Hz	15.00Hz	0.01Hz	○	
F10.06	Speed-loop integral limitation of motor 1	0.0 - 200.0% (motor rated current)	180.0%	0.1%	○	
F10.07	Speed-loop differential time of motor 1	0.00 - 1.00s <i>0.00: There is not the speed-loop differential</i>	0.00s	0.01s	○	
F10.08	Speed-loop output filter time of motor 1	0.000 - 1.000s <i>0.000: the speed-loop filter is disabled</i>	0.020s	0.001s	○	
F10.09	Motor 1 torque limit lock selection	0: Do not lock 1: All of the torque limit is same with FWD electric torque limit	0	1	×	
F10.10	Motor 1 Torque limit channel	Unit: Forward rotation electric torque limit channel Ten: Reverse electric torque limit channel Hundred: Forward rotation torque limit channel Thousand: Reverse rotation torque limit channel 0: Number limit 1: Analog input limit 2: Terminal pulse limit 3 - 6: AI1 - AI4 limit 7: Keypad potentiometer is limited	00000	1	×	
F10.11	Motor torque limitation when motor 1 is forward	0.0 - 200.0% (motor rated current)	180.0%	0.1%	○	
F10.12	Motor torque limitation when motor 1 is reverse	0.0 - 200.0% (motor rated current)	180.0%	0.1%	○	
F10.13	Recreated torque limitation when motor 1 is forward	0.0 - 200.0% (motor rated current)	180.0%	0.1%	○	

Ref. Code	Function	Setting Range	Default	Unit	Attribute	Setting
F10.14	Recreated torque limitation when motor 1 is reverse	0.0 - 200.0% (motor rated current)	180.0%	0.1%	○	
F11: Motor 1 Vector Control Current Loop Parameter (pages 81 - 82)						
F11.00	Motor 1 current loop KP	1 - 2000	400	1	○	
F11.01	Motor 1 current loop KI	1 - 1000	200	1	○	
F11.02	Motor 1 current loop output filter times	0 - 31	3	1	○	
F11.03	Motor 1 current loop feedforward enabled	0: Feedforward is prohibited 1: Enable feedforward	0	1	×	
F11.04	Motor 1 excitation boost setting	0.0 - 30.0%	0.0%	0.1%	×	
F11.05	Motor 1 field orientation optimization setting	Unit: Field orientation angle correction enable 0: Field orientation correction is forbidden 1: Enables magnetic field orientation correction Ten: Mutual inductance projections enabled 0: Disable mutual inductance based on flux calculation 1: Enable mutual inductance based on flux calculation	00	1	×	
F13: Asyn. Motor 2 Parameters (pages 82 -85)						
F13.00	Control mode selection of motor 2	0: V/f control without PG 2: Vector control without PG	0	1	×	
F13.01	Rated power of motor 2	0.2 - 999.9kW	Depend on HD30	0.1kW	×	
F13.02	Rated voltage of motor 2	0 - 999V		1V	×	
F13.03	Rated current of motor 2	5.5kW above: 0.0 - 2500.0A 5.5kW or below: 0.00 - 250.00A		0.1A 0.01A	×	
F13.04	Rated frequency of motor 2	1.0 - 400.0Hz	50.0Hz	0.1Hz	×	
F13.05	Rated speed of motor 2	1 - 24000rpm	Depend on HD30	1rpm	×	
F13.07	Parameter auto-tuning of motor 2	0: Auto-tuning is disabled 1: Stationary auto-tuning 2: Rotary auto-tuning 3: Motor stator resistance measurement	0	1	×	
F13.08	Stator resistance of motor 2	5.5kW below: 0.00 - 99.99Ω	Depend on HD30	0.01Ω	×	
		7.5 - 75kW: 0.000 - 9.999Ω		0.001Ω		
		90kW and above: 0.0000 - 0.9999Ω		0.0001Ω		

Ref. Code	Function	Setting Range	Default	Unit	Attribute	Setting
F13.09	Rotor resistance of motor 2	5.5kW below: 0.00 - 99.99Ω	Depend on HD30	0.01Ω	×	
		7.5 - 75kW: 0.000 - 9.999Ω		0.001Ω		
		90kW and above: 0.0000 - 0.9999Ω		0.0001Ω		
F13.10	Leakage inductance of motor 2	5.5kW below: 0.0 - 5000.0mH		0.1mH	×	
		7.5 - 75kW: 0.00 - 500.00mH		0.01mH		
		90kW and above: 0.000 - 50.000 mH		0.001 mH		
F13.11	Mutual inductance of motor 2	5.5kW below: 0.0 - 5000.0mH	0.1mH	×		
		7.5 - 75kW: 0.00 - 500.00mH	0.01mH			
		90kW and above: 0.000 - 50.000 mH	0.001 mH			
F13.12	Idling exciting current of motor 2	5.5kW and below: 0.0 - 999.9A	0.1A	×		
		5.5kW above: 0.00 - 99.99A	0.01A			
F13.13	Motor 2 core saturation coefficient 1	0.00 - 1.00	1.00	0.01	×	
F13.14	Motor 2 core saturation coefficient 2	0.00 - 1.00	1.00	0.01	×	
F13.15	Motor 2 core saturation coefficient 3	0.00 - 1.00	1.00	0.01	×	
F13.16	V/f curve selection of motor 2	0: Line 1: Square curve 2: 1.2 exponential curve 3: 1.7 exponential curve 4: User-defined curve	0	1	×	
F13.17	V/f frequency value F3 of motor 2	F13.19 - 100.0%	0.0%	0.1%	×	
F13.18	V/f voltage value V3 of motor 2	F13.20 - 100.0%	0.0%	0.1%	×	
F13.19	V/f frequency value F2 of motor 2	F13.21 - F13.17	0.0%	0.1%	×	
F13.20	V/f voltage value V2 of motor 2	F13.22 - F13.18	0.0%	0.1%	×	
F13.21	V/f frequency value F1 of motor 2	0.0% - F13.19	0.0%	0.1%	×	
F13.22	V/f voltage value V1 of motor 2	0.0% - F13.20	0.0%	0.1%	×	
F13.23	Torque boost of motor 2	0.0 - 30.0% 0.0: Auto torque boost	45kW and below: 2.0% 55 - 132 kW: 1.0% 160kW and above: 0.5%	0.1%	×	

Ref. Code	Function	Setting Range	Default	Unit	Attribute	Setting
F13.24	Cut-off point used for manual torque boost of motor 2	0.0 - 50.0% (F13.04)	30.0%	0.1%	○	
F13.25	Slip compensation gain of motor 2	0.0 - 300.0%	0.0%	0.1%	○	
F13.26	Slip compensation filter time of motor 2	0.01 - 10.00s	0.10s	0.01s	○	
F13.27	Slip compensation limitation of motor 2	0.0 - 250.0%	200.0%	0.1%	×	
F13.28	Compensation constant of motor 2	0.000 - 9.999kW	Depend on HD30	0.001kW	×	
F13.30	AVR function of motor 2	0: Disabled 1: Enabled all the time 2: Disabled in Dec. process	1	1	○	
F13.31	Motor 2 low frequency suppression shock coefficient	0 - 200	50	1	○	
F13.32	Motor 2 high frequency suppression shock coefficient	0 - 200	20	1	○	
F13.33	Motor 2 energy saving control select	0: Energy saving control invalid 3: Energy saving according to output current	0	1	×	
F13.34	Motor 2 energy saving factor	0.0 - 100.0%	5.0%	0.1%	○	
F13.35	Speed control proportional gain 1 of motor 2	0.1 - 200.0	10.0	0.1	○	
F13.36	Speed control integral time 1 of motor 2	0.00 - 10.00s	0.20s	0.01s	○	
F13.37	Speed control proportional gain 2 of motor 2	0.1 - 200.0	10.0	0.1	○	
F13.38	Speed control integral time 2 of motor 2	0.00 - 10.00s	0.20s	0.01s	○	
F13.39	Speed-loop PI switching frequency 1 of motor 2	0.00Hz - F13.40	10.00Hz	0.01Hz	○	
F13.40	Speed-loop PI switching frequency 2 of motor 2	F13.39 - 50.00Hz	15.00Hz	0.01Hz	○	
F13.41	Speed-loop integral limitation of motor 2	0.0 - 200.0% (F13.03)	180.0%	0.1%	○	
F13.42	Speed-loop differential time of motor 2	0.00 - 1.00s <i>0.0: There is not the speed-loop differential</i>	0.00s	0.01s	○	
F13.43	Speed-loop output filter time of motor 2	0.000 - 1.000s <i>0.000: The speed-loop filter is disabled</i>	0.000s	0.001s	○	
F13.44	Motor 2 torque limit lock selection	0: Do not lock 1: All of the torque limit is same with FWD electric torque limit	0	1	×	

Ref. Code	Function	Setting Range	Default	Unit	Attribute	Setting
F13.45	Motor 2 Torque limit channel	Unit: Forward rotation electric torque limit channel Ten: Reverse electric torque limit channel Hundred: Forward rotation torque limit channel Thousand: Reverse rotation torque limit channel 0: Number limit 1: Analog input limit 2: Terminal pulse limit 3 - 6: AI1 - AI4 limit 7: Keypad potentiometer is limited	00000	1	×	
F13.46	Motor torque limitation when motor 2 is forward	0.0 - 200.0% (motor rated current)	180.0%	0.1%	○	
F13.47	Motor torque limitation when motor 2 is reverse	0.0 - 200.0% (motor rated current)	180.0%	0.1%	○	
F13.48	Recreated torque limitation when motor 2 is forward	0.0 - 200.0% (motor rated current)	180.0%	0.1%	○	
F13.49	Recreated torque limitation when motor 2 is reverse	0.0 - 200.0% (motor rated current)	180.0%	0.1%	○	
F13.50	Motor 2 current loop KP	1 - 2000	400	1	○	
F13.51	Motor 2 current loop KI	1 - 1000	200	1	○	
F13.52	Motor 2 current loop output filter times	0 - 31	3	1	○	
F13.53	Motor 2 core saturation coefficient 4	0.00 - 1.00	1.00	0.01	×	
F13.54	Motor 2 core saturation coefficient 5	0.00 - 1.00	1.00	0.01	×	
F13.55	Motor 2 current loop feedforward enabled	0: Feedforward is prohibited 1: Enable feedforward	1	1	×	
F13.56	Motor 2 excitation boost setting	0.0 - 30.0%	0.0%	0.1%	×	
F13.57	Motor 2 field orientation optimization setting	Unit: Field orientation angle correction enable 0: Field orientation correction is forbidden 1: Enables magnetic field orientation correction Ten: Mutual inductance projections enabled 0: Disable mutual inductance based on flux calculation 1: Enable mutual inductance based on flux calculation	00	1	×	

Ref. Code	Function	Setting Range	Default	Unit	Attribute	Setting
F13.58	Motor 2 energy start frequency	0.00 - 50.00Hz	25.00Hz	0.01Hz	○	
F13.59	Motor 2 energy switching point	0.0 - 100.0%	100.0%	0.1%	○	
F13.60	Motor 2 energy saving detecting times	0 - 5000 times	10 times	1 times	○	
F13.61	Motor 2 energy voltage recovery time	40 - 4000ms	100ms	1ms	○	
F13.62	Motor 2 energy voltage decreasing time	40 - 4000ms	100ms	1ms	○	
F15: Digital I/O Terminal Parameters (pages 85 - 97)						
F15.00	DI1 function	0: Unused 1: Inverter enabled 2: FWD function 3: REV function 4: Three-wire operation mode 5,6,7: Frequency source selection 1, 2, 3 8: The frequency source switch to analogue setting	2	1	×	
F15.01	DI2 function	9,10: Run command source selection 1,2 11: Switch to terminal control mode 12: External stop command input 13 - 16: Multi-step frequency terminal 1 - 4	3	1	×	
F15.02	DI3 function	17: Frequency ramp (UP) 18: Frequency ramp (DN) 19: Clearing auxiliary frequency setting 20,21: Command control input for forward / reverse jog 1 (JOGF1/ JOGR1) 22,23: Command control input for forward / reverse jog 2 (JOGF2/ JOGR2)	0	1	×	
F15.03	DI4 function	24: Jog 1 command control input 25: Jog 1 direction control input <i>Remark: When select 20 and 21, the functions 24 and 25 are invalid</i> 26: Acc. / Dec. time selection terminals 1 27: Acc. / Dec. time selection terminals 2	0	1	×	

Ref. Code	Function	Setting Range	Default	Unit	Attribute	Setting
F15.04	DI5 function	28: Acc. / Dec. mode selection 29: Acc. / Dec. prohibition 30: Switch to ordinary running mode 31: Reset the stop status of PLC operation 32: Pausing the process PID 33: Disabling the process PID 34: Holding PID integral 35: Clearing PID integral 36: Switch to wobble operation 37: Reset the wobble operating status	0	1	×	
F15.05	DI6 function	38: DC braking start while stopping 39: External pause signal (normally-open input) 40: External pause signal (normally-closed input) 41: Coast to stop (normally-open input) 42: Coast to stop (normally-closed input) 43: Emergency stop	0	1	×	
F15.06	DI7 (option terminal) function	44: External fault signal (normally-open input) 45: External fault signal (normally-closed input) 46: External reset (RST) input 47: Switch between motor 1 and motor 2 48: Timing function input 49: Clearing the length 50: Clearing the counter to zero 51: Counter's triggering signal input 52: Length counting input (only DI6)	0	1	×	
F15.07	DI8 (option terminal) function	53: Pulse frequency input (only DI6) 54: Main and auxiliary frequency source switching 56: Speed control / torque control switching 57: Torque control torque polarity switching 59: PID parameter switch 85: Pausing PLC operation 86: Terminal stop DC braking	0	1	×	

Ref. Code	Function	Setting Range	Default	Unit	Attribute	Setting
F15.08	DI9 (option terminal) function	87: Frequency setting channel selection 4	0	1	×	
F15.12	Acc. / Dec. rate of UP/DN terminal	0.00 - 99.99Hz/s	1.00Hz/s	0.01Hz/s	×	
F15.13	Terminal detecting interval	0: 2ms 1: 4ms 2: 8ms	0	1	○	
F15.14	Terminal detecting filter number	0 - 10000	2	1	○	
F15.15	Terminal input positive and negative logic setting	Bit0 - Bit8 is corresponding to DI1 - DI9 Bitx: Dly terminal input positive and negative logic 0: Positive logic 1: Negative logic <i>Only Only when using HD30-EIO will DI7 - DI9 be enabled</i>	000	1	○	
F15.16	FWD/REV operation mode	0: Two-wire operation mode 1 1: Two-wire operation mode 2 2: Three-wire operation mode 1 3: Three-wire operation mode 2	0	1	×	
F15.17	Terminal operating selection due to fault of external equipment	0: Coast to stop 1: Emergency stop 2: Dec. to stop 3: Continue to run	0	1	×	
F15.18	DO1 function	0: Unused 1: Inverter ready 2: Inverter is running (RUN) 3: Inverter is forward running 4: Inverter is reverse running 5: Inverter is DC braking	2	1	○	
F15.19	DO2 function	6: Inverter is in zero-frequency status 7: Inverter is in zero-frequency running 9,10: Frequency detection threshold (FDT1,FDT2) 11: Frequency arriving signal (FAR)	0	1	○	
F15.20	RLY1 function	12: Limitation of upper limit of frequency 13: Limitation of lower limit of frequency 14: Limitation of upper/lower limits of wobble frequency	31	1	○	

Ref. Code	Function	Setting Range	Default	Unit	Attribute	Setting
F15.21	RLY2 (extension relay) function	15: Simple PLC operating status indication 16: Simple PLC pausing indication 17: Simple PLC cycle completion indication 18: Completion of simple PLC operation stages 19: Completion of simple PLC operation 20: Output data from SCI communication	0	1	○	
F15.22	RLY3 (extension relay) function	21: Preset operating time out 22: Timing function output 23: Preset counting value reach 24: Indicating counting value reach 25: Setting length arrive 26: Indication of motor 1 and motor 2 27: Analog input overrun output	0	1	○	
F15.23	RLY4 (extension relay) function	29: Undervoltage lock-up signal (LU) 30: Overload signal (OL) 31: Inverter fault 32: External fault 33: Inverter auto-reset fault 35: Dormancy instruction function 36: The system is running 38: High-frequency output (only DO2)	0	1	○	
F15.24	Output terminal positive and negative logic selection	Bit0 – Bit1 is corresponding to DO1 - DO2 Bit2 - Bit5 is corresponding to RLY1 - RLY4 Bitx: DOy and RLYy terminals output positive and negative logic 0: Positive logic 1: Negative logic <i>Only when using HD30-EIO will RLY2 - RLY4 be enabled</i>	000	1	○	
F15.25	ON side delay time of timing function	0.00 - 300.00s	0.00s	0.01s	○	
F15.26	OFF side delay time of timing function	0.00 - 300.00s	0.00s	0.01s	○	

Ref. Code	Function	Setting Range	Default	Unit	Attribute	Setting
F15.27	FAR range	0.00 - 100.00Hz	2.50Hz	0.01Hz	○	
F15.28	Zero-frequency operation threshold	0.00 - upper limit	0.00Hz	0.01Hz	○	
F15.29	Zero-frequency hysteresis	0.00 - upper limit	0.00Hz	0.01Hz	○	
F15.30	FDT1 detection mode	0: Detect according to the reference frequency 1: Detect according to the output frequency	0	1	○	
F15.31	FDT1 level	0.00 - upper limit	50.00Hz	0.01Hz	○	
F15.32	FDT1 lag	0.00 - upper limit	1.00Hz	0.01Hz	○	
F15.33	FDT2 detection mode	0: Detect according to the reference frequency 1: Detect according to the output frequency	0	1	○	
F15.34	FDT2 level	0.00 - F00.06	50.00Hz	0.01Hz	○	
F15.35	FDT2 lag	0.00 - F00.06	1.00Hz	0.01Hz	○	
F15.36	Preset operating time	0 - 65535h <i>0: Preset operating time is disabled</i>	0h	1h	○	
F15.37	Preset counting value arriving	F15.38 - 9999	0	1	○	
F15.38	Specified counting value arriving	0 - F15.37	0	1	○	
F15.39	Ananlogue input over-limitation selection	Unit: Action drive when the input exceeds the limit 0: Free stop 1: Emergency shutdown 2: Dec. stop 3: No action Ten: Select the analog input port 0: No analog port 1: Operation panel potentiometer 2: AI1 port 3: AI2 port Hundred: Analog overrun detection conditions 0: Always detected 1: Run command is detected	0000	1	×	

Ref. Code	Function	Setting Range	Default	Unit	Attribute	Setting
F15.39	Analogue input over-limitation selection	Thousand: Automatic selection when analog overrun is detected 0: Do not allow automatic operation 1: Allows automatic operation	0000	1	×	
F15.40	Analog input overrun upper limit	F15.41 - 100.0%	100.0%	0.1%	○	
F15.41	Analog input overrun down limit	0.0% - F15.40	0.0%	0.1%	○	
F15.42	Analog overrun detection time	0.00 - 50.00s	5.00s	0.01s	○	
F15.43	Terminal output delay	0.0 - 100.0s	0.0s	0.1s	○	
F15.44	Start analog overrun detection time	0.00 - 50.00s	15.00s	0.01s	○	
F16: Analogue I/O Terminal Parameters (pages 97 - 101)						
F16.00	Display panel with potentiometer function selection	0: Unused 1: Upper limit frequency setting source 2: Frequency setting source 3: Auxiliary frequency reference 4: Process PID reference 5: Process PID feedback 6: Process PID regulating upper limit	0	1	×	
F16.01	AI1 function	7: Process PID regulating lower limit 8: Motor overheating signal input 9: Motor 1 forward rotation torque limit 10: Motor 1 reverse electric torque limit	2	1	×	
F16.02	AI2 function	11: Motor 1 forward regeneration rotation torque limit 12: Motor 1 reverse regeneration rotation torque limit 13: Torque command given	5	1	×	
F16.03	AI3 function	15: Torque control up limit frequency 16: Motor 2 Forward rotation electrical torque limit 17: Motor 2 reverse rotation electrical torque limit 18: Motor 2 Forward regeneration torque limit	0	1	×	

Ref. Code	Function	Setting Range	Default	Unit	Attribute	Setting
F16.04	Al4 function	19: Motor 2 reverse regeneration torque limit	0	1	×	
F16.05	Al1 bias	-100.0 - 100.0%	0.0%	0.1%	○	
F16.08	Al2 bias	-100.0 - 100.0%	0.0%	0.1%	○	
F16.11	Al3 bias	-100.0 - 100.0%	0.0%	0.1%	○	
F16.14	Al4 bias	-100.0 - 100.0%	0.0%	0.1%	○	
F16.06	Al1 gain	-10.00 - 10.00	1.00	0.01	○	
F16.09	Al2 gain	-10.00 - 10.00	1.00	0.01	○	
F16.12	Al3 gain	-10.00 - 10.00	1.00	0.01	○	
F16.15	Al4 gain	-10.00 - 10.00	1.00	0.01	○	
F16.07	Al1 filtering time	0.01 - 10.00s	0.05s	0.01s	○	
F16.10	Al2 filtering time	0.01 - 10.00s	0.05s	0.01s	○	
F16.13	Al3 filtering time	0.01 - 10.00s	0.05s	0.01s	○	
F16.16	Al4 filtering time	0.01 - 10.00s	0.05s	0.01s	○	
F16.17	Max. input pulse frequency	0.0 - 50.0kHz	10.0kHz	0.1kHz	○	
F16.18	Input pulse filtering time	0 - 500ms	10ms	1ms	○	
F16.19	AO1 function	0: Unused 1: Output frequency (0 - max. output frequency) 2: Reference frequency (0 - max. output frequency) 3: Motor speed (0 - max. output frequency corresponding to speed) 4: Output current (0 - twice motor's rated current) 5: Output current (0 - twice motor's rated current) 6: Torque command(0 - 3 times motor rated torque) 10: Output torque (0 - 3 times motor's rated torque)	2	1	○	
F16.20	AO2 function	11: Output voltage (0 - 1.2 times inverter's rated voltage) 12: Bus voltage (0 - 2.2 times inverter's rated voltage) 13: Output power (0 - twice motor's rated power) 14: Al1 input (0 - 10V) 15: Al2 input (-10 - 10V / 0 - 20mA) 16: Al3 input (-10 - 10V / 0 - 20mA) 17: Al4 input (-10 - 10V / 0 - 20mA)	0	1	○	



Ref. Code	Function	Setting Range	Default	Unit	Attribute	Setting
F16.21	High-speed pulse output function	18: Output frequency (-1 times - 1 times max. output frequency) 19: Reference frequency (-1 times - 1 times max. output frequency) 20: Set frequency (0 - max. output frequency)	0	1	○	
F16.22	Analogue output AO1 bias	-100.0 - 100.0%	0.0%	0.1%	○	
F16.23	Analogue output AO1 gain	0.0 - 200.0%	100.0%	0.1%	○	
F16.24	Analogue output AO2 bias	-100.0 - 100.0%	0.0%	0.1%	○	
F16.25	Analogue output AO2 gain	0.0 - 200.0%	100.0%	0.1%	○	
F16.26	DO2 max. output pulse frequency	0.1 - 50.0kHz	10.0kHz	0.1kHz	○	
F16.27	Keypad potentiometer offset	-100.0 - 100.0%	0.0%	0.1%	○	
F16.28	Keypad potentiometer gain	0.00 - 10.00	1.00	0.01	○	
F17: SCI Communication Parameters (pages 101 - 102)						
F17.00	Data format	0: 1-8-2 format, no parity, RTU 1: 1-8-1 format, even parity, RTU 2: 1-8-1 format, odd parity, RTU 6: 1-8-11 format, no parity, RTU	0	1	×	
F17.01	Baud rate selection	0: 1200bps 1: 2400bps 2: 4800bps 3: 9600bps 4: 19200bps 5: 38400bps 6: 57600bps 7: 76800bps 8: 115200bps	3	1	×	
F17.02	Local address	0 - 247	2	1	×	
F17.03	Host PC response time	0 - 1000ms	1s	1ms	×	
F17.04	Time threshold for detecting communication status	0.0 - 600.0s <i>0.0: Not detect communication time out</i>	0.0s	0.1s	×	
F17.05	Detecting time at communication error	0.0 - 600.0s <i>0.0: Not detect the communication error</i>	0.0s	0.1s	×	
F17.06	Action selection at communication time out	0: Coast to stop 1: Emergency stop 2: Dec. to stop 3: Continue to run	3	1	×	
F17.07	Action selection at communication fault		3	1	×	
F17.08	Action selection at communication peripheral device fault		1	1	×	

Ref. Code	Function	Setting Range	Default	Unit	Attribute	Setting
F17.09	Communication write function parameter of storage EEPROM method selection	Unit: Except of F00.13, F19.03, EEPROM storage selection in communication 0: Not stored in EEPROM 1: Stored in EEPROM Ten: For F00.13, F19.03, EEPROM storage selection in communication 0: Not stored in EEPROM 1: Stored in EEPROM	01	1	×	
F17.10	Detecting time of network communicaiton overtime	0.0 - 600.0s <i>0.0: Not detected the communication timeout</i>	0.0s	0.1s	×	
F18: Display Control Parameters (pages 102 - 103)						
F18.00	Language selection	0: Chinese 1: English	0	1	○	
F18.01	Displaying contrast of the LCD keypad	1 - 10	5	1	○	
F18.02	Set the display parameter 1 during operation	0: Unused 1: Inverter's rated current 3: Inverter status 4: Master setting frequency source	8	1	○	
F18.03	Set the display parameter 2 during operation	5: Master setting frequency 6: Auxiliary setting frequency 7: Setting frequency	7	1	○	
F18.04	Set the display parameter 3 during operation	8: Reference frequency (after Acc. / Dec.) 9: Output frequency 10: Setting speed	9	1	○	
F18.05	Set the display parameter 4 during operation	11: Running speed 13: Output voltage 14: Output current	13	1	○	
F18.06	Set the display parameter 5 during operation	15: Torque given 16: Output torque 17: Output power 18: DC bus voltage	14	1	○	
F18.07	Set the display parameter 6 during operation	19: Potentiometer input voltage 20: AI1 input voltage 21: AI1 input voltage (after disposal)	18	1	○	
F18.08	Set the display parameter 1 at stop	22: AI2 input voltage 23: AI2 input voltage (after disposal) 24: AI3 input voltage	7	1	○	

Ref. Code	Function	Setting Range	Default	Unit	Attribute	Setting
F18.09	Set the display parameter 2 at stop	25: AI3 input voltage (after disposal) 26: AI4 input voltage 27: AI4 input voltage (after disposal)	18	1	○	
F18.10	Set the display parameter 3 at stop	28: DI6 terminal pulse input frequency 29: AO1 output 30: AO2 output 31: High-speed output pulse frequency	20	1	○	
F18.11	Set the display parameter 4 at stop	32: Heatsink temperature 33: Set the line speed 34: Reference line speed 37: Process PID reference 38: Process PID feedback 39: Process PID error	22	1	○	
F18.12	Set the display parameter 5 at stop	40: Process PID integral value 41: Process PID output 42: External counting value 43: Input terminal status 44: Output terminal status 45: MODBUS communication status	43	1	○	
F18.13	Set the display parameter 6 at stop	46: Actual length 47: Total length 48: Total time at power on (hour) 49: Total time at running (hour)	44	1	○	
F18.14	Frequency display gain	0.1 - 160.0	1.0	0.1	○	
F18.15	Max. line speed	0 - 65535	1000	1	○	
F18.16	Line speed display accuracy	0: Integer 1: One decimal 2: Two decimal 3: Three decimal	0	1	○	
F19: Function-boost Parameters (pages 103 - 111)						
F19.00	Auxiliary frequency setting source selection	0: No auxiliary source 1: Digital setting 1 (the initial value is set by F19.03 and adjusted by ▲ and ▼ keys on the keypad) 2: Digital setting 2 (the initial value is set by F19.03 and adjusted by terminals UP/DN) 3: Digital setting 3 (the initial value = 0, set by SCI direct communication)	0	1	○	

Ref. Code	Function	Setting Range	Default	Unit	Attribute	Setting
		4: AI analogue setting 5: Terminal pulse setting 6: Process PID output 7 - 10: AI1 - AI4 11: Keypad potentiometer				
F19.01	Master/Auxiliary setting calculation	Unit: Main and auxiliary operations 0: Master setting + auxiliary setting 1: Master setting - auxiliary setting Ten: Frequency source switch selection 0: Main 1: Main and auxiliary operations 2: Main and auxiliary switching 3: Master and main auxiliary operation switch 4: Auxiliary and main auxiliary operation switch	10	1	○	
F19.02	Analogue auxiliary setting coefficient	0.00 - 9.99	1.00	0.01	○	
F19.03	Initial value of digital auxiliary frequency	0.00 - F00.06	0.00Hz	0.01Hz	○	
F19.04	Control selection of digital auxiliary frequency	Unit: Save selection at power outage (Only when F19.00 = 1 or 2 will F19.04 be enabled) 0: Not save auxiliary frequency at power outage 1: The auxiliary frequency will be saved to F19.03 at power outage Ten: Frequency disposal when the inverter stops 0: Maintain the auxiliary frequency when the inverter stops 1: The auxiliary frequency clears to zero when the inverter stops	00	1	○	
F19.05	Adjustment selection of setting frequency	0: No adjustment 1: To adjust as per the max. output frequency 2: To adjust as per the current frequency	1	1	○	
F19.06	Adjustment coefficient of setting frequency	0.0 - 200.0%	100.0%	0.1%	○	

Ref. Code	Function	Setting Range	Default	Unit	Attribute	Setting
F19.07	Control selection of cooling fan	0: Auto stop mode 1: Immediate stop mode 2: The fan runs continuously when power on	0	1	○	
F19.08	Cooling fan controls delaying time	0.0 - 600.0s	60.0s	0.1s	○	
F19.10	Zero-frequency threshold	0.00 - upper limit	1.00 Hz	0.01Hz	○	
F19.11	Action selection at setting frequency is lower than zero-frequency threshold	0: Run according to frequency command 1: Holding stop, no output 2: Run according to zero-frequency threshold 3: Run according to zero-frequency	0	1	×	
F19.12	Trip-free selection at momentary power loss	0: This function is disabled 1: This function is enabled	0	1	×	
F19.13	Dec. time at voltage compensation	0.1 - 6000.0s	5.0s	0.1s	○	
F19.15	Reference voltage of trip-free operation at momentary power loss	220V inverter: 210 - 370V	248V	1V	×	
		380V inverter: 400 - 670V	430V			
		660V inverter: 620 - 1130V	747V			
F19.16	Restart after power failure	0: This function is disabled 1: This function is enabled	0	1	×	
F19.17	Delay time for restart after power failure	0.00 - 10.00s	2.00s	0.01s	○	
F19.18	Overvoltage suppression gain	0.000 - 1.000 <i>0.000: Overvoltage stall is prohibited</i>	0.500	0.001	○	
F19.19	Stall overvoltage point	220V inverter: 350 - 400V	390V	1V	○	
		380V inverter: 650 - 790V	690V			
		660V inverter: 900 - 1180V	1150V			
F19.20	Auto current limiting selection	0.000 - 1.000 <i>0.000: The automatic current limit is invalid</i>	0.500	0.001	○	
F19.21	Auto current limiting threshold	20.0 - 200.0%	G: 150.0% P: 110.0%	0.1%	○	
F19.23	Enabled mode of terminal run command	0: Rise edge enabled mode 1: Level enabled mode	0	1	○	
F19.24	Action voltage of braking unit	220V inverter: 330 - 400V	380V	1V	○	
		380V inverter: 630 - 750V	720V			
		660V inverter: 980 - 1120V	1130V			
F19.25	Flux brake enabled	0: Prohibited 1: Enable	0	1	○	
F19.26	Preset length	0 - 65535m	0m	1m	○	
F19.27	Actual length	0 - 65535m	0m	1m	*	

Ref. Code	Function	Setting Range	Default	Unit	Attribute	Setting
F19.28	Length ratio	0.001 - 30.000	1.000	0.001	○	
F19.29	Length checking coefficient	0.001 - 1.000	1.000	0.001	○	
F19.30	Measuring shaft diameter	1.00 - 100.00cm	10.00cm	0.01cm	○	
F19.31	Number of pulses per revolution	1 - 9999	1	1	○	
F19.32	Length arrive and output function selection	0: Output level signal 1: Output 500ms pulse	0	1	○	
F19.33	Record of length disposal after length arrive	0: Auto-clear 1: No change	0	1	○	
F19.34	Record of length disposal at stop	0: Auto-clear 1: No change	0	1	○	
F19.35	Auxiliary PID output limit	0.0 - 100.0%	100.0%	0.1%	×	
F19.36	Auxiliary PID output limit increase	0.0 - 100.0%	0.0%	0.1%	×	
F19.37	Frequency adjust range selection	Unit: The main frequency calculation range 0: 0 to max. frequency 1: Negative max. frequency to max. frequency Ten: Auxiliary frequency calculation range 0: 0 to max. frequency 1: Negative max. frequency to max. frequency Hundred: Synthetic frequency calculation range 0: 0 to the upper limit frequency 1: Negative upper limit frequency to upper limit frequency	100	1	○	
F19.38	Phase short circuit detection action selection	0: No detection 1: Detection	1	1	○	
F19.39	Input voltage selection	Unit: 380V model input voltage selection 0: 380 - 460V 1: 260 - 460V 2: 200 - 460V Ten: 220V model input voltage selection 0: 200 - 240V 1: 120 - 240V	0	1	×	

Ref. Code	Function	Setting Range	Default	Unit	Attribute	Setting
F19.39	Input voltage selection	Hundred: 660V model input voltage selection 0: 500 - 690V 1: 380 - 690V 2: 260 - 690V	0	1	×	
F19.40	Flux brake PI regulator Kp	0 - 4000	1000	1	○	
F19.41	Flux brake PI regulator Ki	0 - 500	20	1	○	
F20: Protection of Fault Parameters (pages 111 - 115)						
F20.00	Overload pre-alarm detection	Unit: Overload pre-alarm detection 0: It is active all the time in running status 1: It is active only at constant speed Ten: Action selection for overload pre-alarm 0: The inverter doesn't alarm and continues operation when detecting an active overload signal 1: The inverter alarms and stops operation when detecting an active overload signal Hundred: Overload threshold selection 0: Ratio of load current to the motor's rated current (alarm: motor overload) 1: Ratio of load current to the inverter's rated current (alarm: inverter overload) Thousand: Motor type selection 0: Standard motor 1: Variable frequency Ten thousand: Overload protection 0: Overload protection is enabled 1: Overload protection is disabled 2: Shielded inverter overload protection, enable motor overload protection 3: Shielded inverter overload protection, motor overload protection	00000	1	○	

Ref. Code	Function	Setting Range	Default	Unit	Attribute	Setting
F20.01	Overload pre-alarm detection threshold	20.0 - 200.0%	150.0%	0.1%	○	
F20.02	Overload pre-alarm detection time	0.0 - 60.0s	5.0s	0.1s	○	
F20.03	Inverter output load-loss detection	0: Disabled 1: It is detecting all the time in running process, and then continues operation after detecting (alarm) 2: It detects only at the same speed, and then continues operation after detecting (alarm) 3: It is detecting all the time in running process, and then cut off the output after detecting (fault) 4: It is detects only at the same speed, and then cut off the output after detecting (fault)	0	1	○	
F20.04	Inverter output load-loss detection threshold	0 - 100%	30%	1%	○	
F20.05	Inverter output load-loss detection time	0.00 - 20.00s	1.00s	0.01s	○	
F20.06	Motor overheating signal input type	0: Does not detect the motor overheating 1: Positive characteristic (PTC) 2: Negative characteristic (NTC)	0	1	○	
F20.07	Thermistor value at motor overheating	0.0 - 10.0kΩ	5.0kΩ	0.1kΩ	○	
F20.08	Input phase loss detection reference	0 - 80% 0%: <i>Not detect input phase loss fault</i>	30%	1%	○	
F20.09	Input phase loss detection time	1.00 - 5.00s	1.00s	0.01s	○	
F20.10	Output phase loss detection reference	0 - 100% 0%: <i>Not detect output phase loss fault</i>	20%	1%	○	
F20.11	Output phase loss detection time	1.00 - 20.00s	3.00s	0.01s	○	
F20.12	PID reference lose detected value	0 - 100% 0%: <i>Does not detect PID reference lose</i>	0%	1%	○	
F20.13	PID reference loss detection time	0.00 - 10.00s 0.00s: <i>Does not detect PID reference loss</i>	0.20s	0.01s	○	

Ref. Code	Function	Setting Range	Default	Unit	Attribute	Setting
F20.14	PID feedback loss detected value	0 - 100% <i>0%: Does not detect PID feedback loss</i>	0%	1%	<input type="radio"/>	
F20.15	PID feedback loss detection time	0.00 - 10.00s <i>0.00s: Does not detect PID feedback loss</i>	0.20s	0.01s	<input type="radio"/>	
F20.16	Detection value at PID feedback out of the limit	0 - 100% <i>100%: Does not detect PID feedback out of the limit</i>	100%	1%	<input type="radio"/>	
F20.17	Detection time at PID feedback out of the limit	0.00 - 10.00s <i>0.00s: Does not detect PID feedback out of the limit</i>	0.20s	0.01s	<input type="radio"/>	
F20.18	Auto reset times	0 - 100 <i>0: No auto reset function</i>	0	1	<input type="radio"/>	
F20.19	Auto reset interval	0.01 - 200.00s/time	5.00s/time	0.01s/time	<input type="radio"/>	
F20.20	Faulted relay action selection	Unit: In auto reset process 0: Faulted relay doesn't act 1: Faulted relay acts Ten: In the undervoltage process 0: Faulted relay doesn't act 1: Faulted relay acts	00	1	<input type="radio"/>	
F20.21	Type of fifth latest (the last) fault	E0001: Acc. overcurrent E0002: Dec. overcurrent E0003: Costant overcurrent E0004: Acc. overvoltage E0005: Dec. overvoltage E0006: Constant overvoltage E0007: Stall overvoltage E0008: Fault of power module E0009: Heatsink overheat E0010: Fault of braking unit E0011: CPU fault E0012: Parameters auto-tuning fault E0013: Contactor is not actuated E0014: Fault of current detection circuit E0015: Fault of input phase E0016: Fault of output phase E0017: Inverter overload E0018: Inverter output is unloaded E0019: Motor overload	0	1	*	

Ref. Code	Function	Setting Range	Default	Unit	Attribute	Setting
		E0020: Motor overheat E0021: Access fault of control board EEPROM E0022: Access fault of keypad EEPROM (only displaying without any protection) E0023: Fault setting of parameters E0024: Fault of external equipment E0025: PID reference loss E0026: PID feedback loss E0027: PID feedback out of limiting E0028: SCL communication time-out E0029: SCL communication error				
F20.22	Setting frequency at the last fault	0.00 - 400.00Hz	0Hz	0.01Hz	*	
F20.23	Running frequency at the last fault	0.00 - 400.00Hz	0Hz	0.1Hz	*	
F20.24	Bus voltage at the last fault	0 - 1999V	0V	1V	*	
F20.25	Output voltage at the last fault	0 - 999V	0V	1V	*	
F20.26	Output current at the last fault	7.5kW or above: actual value	0.0A	0.1A	*	
		5.5kW or below: actual value	0.00A	0.01A		
F20.27	Input terminal status at the last fault	0 - 0x1FF	0	1	*	
F20.28	Output terminal status at the last fault	0 - 0x7FF	0	1	*	
F20.29	Interval of fifth latest fault	0 - 6553.5 hours	0.0	0.1h	*	
F20.30	Type of fourth latest fault	0 - 99	0	1	*	
F20.31	Interval of fourth latest fault	0.0 - 6553.5 hours	0.0	0.1h	*	
F20.32	Type of third latest fault	0 - 99	0	1	*	
F20.33	Interval of third latest fault	0.0 - 6553.5 hours	0.0	0.1h	*	
F20.34	Type of second latest fault	0 - 99	0	1	*	
F20.35	Interval of second latest fault	0.0 - 6553.5 hours	0.0	0.1h	*	
F20.36	Type of first latest fault	0 - 99	0	1	*	
F20.37	Interval of first latest fault	0.0 - 6553.5 hours	0.0	0.1h	*	
F20.38	Last fault interval	0.0 - 6553.5 hours	0.0	0.1h	*	
F21: Torque Control Parameters (pages 115 -116)						
F21.00	Torque command given channel selection	0: F21.01 digital set 1: Analogue set 2: Terminals pulse set 3: SCL communicaiton set	0	1	×	

B

Ref. Code	Function	Setting Range	Default	Unit	Attribute	Setting
F21.01	Torque command digital setting	-100.0 - 100.0 % (F21.02)	0.0%	0.1%	○	
F21.02	Max. Torque setting	0.0 - 500.0% (F08.04)	100.0%	0.1%	×	
F21.03	Filter time of torque command	0.000 - 1.000s	0.000s	0.001s	○	
F21.04	Speed limit selection in torque control	0: Defined by F21.05, F21.06 1: Defined by F00.06 (max. output frequency) 2: Limited by analog quantity	1	1	×	
F21.05	Positive speed limit selection in torque control	0 - 100% (F00.06)	100%	1%	○	
F21.06	Reverse speed limit selection in torque control	0 - 100% (F00.06)	100%	1%	○	
F21.10	Stop mode selection of torque control	0: Dec. stop + DC braking 1: Stop torque output 2: Free stop	0	1	×	
F23: PWM Control Parameters (pages 116 - 116)						
F23.00	Set the carrier frequency	1 - 16kHz	Depend on HD30	1kHz	×	
F23.01	Carrier frequency is automatically adjusted	0: The carrier frequency is disabled automatically 1: Carrier frequency auto adjustment 1 2: Carrier frequency automatic adjustment 2	1	1	×	
F23.02	PWM overshoot enable	0: Disabled 1: Enabled	1	1	×	
F23.03	PWM modulation mode	0: Two-phase modulation or three-phase modulation 1: Three-phase modulation 2: Two-phase modulation	0	1	×	
F23.04	PWM Modulation mode switching point1	0.00 - 50.00Hz	Depend on HD30	0.01Hz	×	
F23.05	PWM Modulation mode switching point2	0.00 - 50.00Hz	Depend on HD30	0.01Hz	×	
F23.09	Random carrier frequency coefficient K1	0 - 2000	2	1	×	
F23.10	Random carrier frequency coefficient K2	0 - 2000	3	1	×	
Group U: User Menu Mode Display Parameters (pages 116 - 117)						
U00.00	User menu map of setting 1	00.00 - 23.02, 99.99 <i>99.99 is corresponding to no parameter mapping function</i>	00.01	0.01	○	
U00.02	User menu map of setting 2		00.06	0.01	○	
U00.04	User menu map of setting 3		00.08	0.01	○	
U00.06	User menu map of setting 4		00.13	0.01	○	
U00.08	User menu map of setting 5		00.10	0.01	○	

Ref. Code	Function	Setting Range	Default	Unit	Attribute	Setting
U00.10	User menu map of setting 6		00.11	0.01	○	
U00.12	User menu map of setting 7		02.13	0.01	○	
U00.14	User menu map of setting 8		03.01	0.01	○	
U00.16	User menu map of setting 9		03.02	0.01	○	
U00.18	User menu map of setting 10		08.00	0.01	○	
U00.20	User menu map of setting 11		08.01	0.01	○	
U00.22	User menu map of setting 12		08.02	0.01	○	
U00.24	User menu map of setting 13		08.03	0.01	○	
U00.26	User menu map of setting 14		08.04	0.01	○	
U00.28	User menu map of setting 15		-	0.01	○	
U00.30	User menu map of setting 16		-	0.01	○	
U00.01	The setting value of map 1			-		-
U00.03	The setting value of map 2	-			-	
U00.05	The setting value of map 3	-			-	
U00.07	The setting value of map 4	-			-	
U00.09	The setting value of map 5	-			-	
U00.11	The setting value of map 6	-			-	
U00.13	The setting value of map 7	-			-	
U00.15	The setting value of map 8	-			-	
U00.17	The setting value of map 9	-			-	
U00.19	The setting value of map 10	-			-	
U00.21	The setting value of map 11	-			-	
U00.23	The setting value of map 12	-			-	
U00.25	The setting value of map 13	-			-	
U00.27	The setting value of map 14	-			-	
U00.29	The setting value of map 15	-			-	
U00.31	The setting value of map 16	-			-	

Appendix C Communication Protocol



1. Introduction

HD30 series inverters provide one RS485 communication interface which uses the standard MODBUS communication protocol.

By using the host computer (including communication devices such as computer and PLC) the user can operate to read-write the inverter's function code, read the status parameters and write the control command etc. The inverter is in slave mode when it is communicating.

Communication Terminal

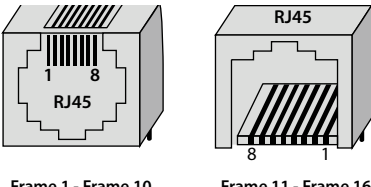
The communication terminal is shown in following table.

Type	Name	Terminal description	
 <p>Frame 1 - Frame 10 Frame 11 - Frame 16</p>	SCI terminal	Pin	Definition
		1,3	+5V
2		485+	
4,5,6		GND	
7		485-	
8		Unused	
	Terminal	Terminal	Description
		A	485+
		B	485-

The transmitting mode is shown in following table.

Port	Asyn, half-duplex
Format	1-8-2 (1 start bit, 8 data bits, 2 stop bits), no parity, RTU
Baut rate	9600bps
Relative setting	Refe to F17: SCI Communication Parameters, on page 101

Network Mode

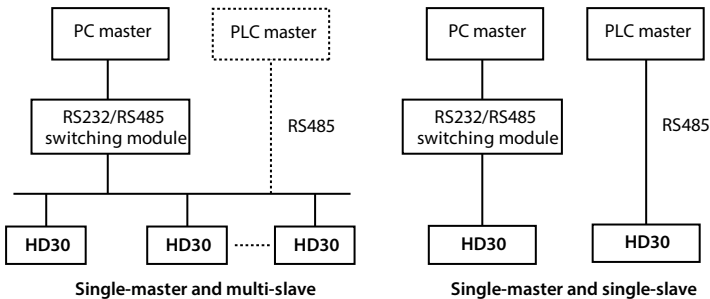

Protocol Format

The MODBUS protocol simultaneously supports RTU mode, with corresponding frame format as shown below:

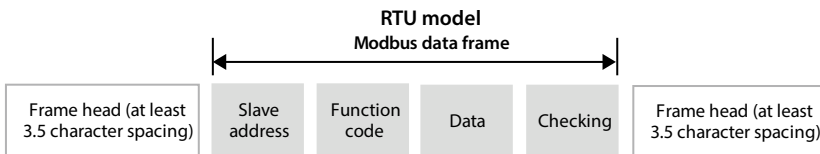

MODBUS adopts “Big Endian” encoding mode, higher byte prior to lower byte at sending.

In the RTU mode

- The idle time of frame head and frame tail passing bus should be not less than 3.5 bytes.
- Slave address=0, it means broadcast address.
- Data checking relies on CRC-16. The whole information need be checked. The concrete CRC checking is referred to the page 184.

For example: To read the slave internal register F00.08 = 50.00Hz of No. 1 address:

Command frame	Address	Parameter	Register address		Read char no.		Checksum	
	0x01	0x03	0x00	0x08	0x00	0x01	0x05	0xC8
Response frame	Address	Parameter	Response byte		Content of register		Checksum	
	0x01	0x03	0x02		0x13	0x88	0xB5	0x12

2. Scaling of Drive Transmitting Values

Except the parameters of the remarks, all other function codes can define the scaling relationship of the specified function code via referring the manual's min. unit.

Remarks:

1. Communication data for F04.03, F21.01, F16.05, F16.08, F16.11, F16.14, F16.22, F16.24 0 - 2000 corresponding data -1000 - +1000.
2. Status parameter 0x3318 communication data 0 - 16000 corresponds to data -8000 - +8000.
3. Status parameters: AI2 - AI4 input voltage, AI2 - AI4 input voltage (after processing), process PID reference, process PID feedback, process PID error, process PID integral item and process PID output communication data 0-2000 Corresponding data -1000 - + 1000.

3. Protocol Function

Supported function

MODBUS protocol supports the below parameter operation:

Supported function	Code	Instructions
To read function parameters and status parameter	0x03	
To rewrite single function parameter or control parameter	0x06	Saving or not is set by F17.09 in power failure
	0x41	Not saved at power off
To rewrite numbers of function parameters or control parameters	0x10	Saving or not is set by F17.09 in power failure
	0x43	Saved at power off

To read function parameters and status parameter

Function code 0x03, command frame and response frame are in below table.

Command frame	Address	Code	Starting register address	No. of register	CRC/LRC checking
Data frame bytes	1	1	2	2	2/1
Value or range	0 - 247	0x03	0x0000 - 0xFFFF	0x0001 - 0x000C	

Response frame	Address	Code	Read byte no.	Register content	CRC/LRC checking
Data frame bytes	1	1	1	2* no. of registers	2/1
Value or range	1 - 247	0x03	2* no. of registers		

To rewrite single function parameter or control parameter

Function code 0x06 (saving or not is set by F17.09 in power failure) or 0x41 (not save at power off);

Command frame and response frame are in below table.

Command frame	Address	Code	Register address	Register content	CRC/LRC checking
Data frame bytes	1	1	2	2	2/1
Value or range	0 - 247	0x06, 0x41	0x0000 - 0xFFFF	0x0000 - 0xFFFF	

Response frame	Address	Code	Register address	Register content	CRC/LRC checking
Data frame bytes	1	1	2	2	2/1
Value or range	1 - 247	0x06, 0x41	0x0000 - 0xFFFF	0x0000 - 0xFFFF	

To rewrite numbers of function parameters or control parameters

Function code 0x06 (saving or not is set by F17.09 in power failure) or 0x43 (save at power off); command frame and response frame are in below table.

Command frame	Address	Code	Starting register address	No. of register	Byte no. of register content	Register content	CRC/LRC checking
Data frame bytes	1	1	2	2	1	2* no. of operation registers	2/1
Value or range	0 - 247	0x10, 0x43	0x0000 - 0xFFFF	0x0000 - 0x0004	2* no. of operation registers		

Response frame	Address	Code	Starting register address	No. of operation registers	CRC checking
Data frame bytes	1	1	2	2	2/1
Value or range	1 - 247	0x10, 0x43	0x0000 - 0xFFFF	0x0000 - 0x0004	

This command rewrites the contents of continuous data unit from starting register address where is mapped as function parameter and control parameter of controller, etc.

The inverter will start to save from low address to high address of the register when it continuously saves many register parameters. The saving will return from the firstly failed address if the saving process isn't completely successful.

Fault and exception code

If the operation command fails, the response is fault code. The fault code is + 0x80. Below is the instruction for the exception codes.

Exception code	Instructions
0x01	Illegal function parameters.
0x02	Illegal register address.
0x03	Data fault. Data is exceeded the upper/lower limit.
0x04	Slave operation fails (including fault caused by data invalid).
0x16	Unsupported operation (unsupported to read the attributes, factory default and upper / lower limit for the control parameter and status parameter).
0x17	The register number of command frame is fault.
0x18	Incorrect information frame, including incorrect information length and incorrect checking.
0x20	Parameters cannot be modified.
0x21	Parameters are unchangeable when the controller is in running status.
0x22	Parameters are protected by password.

4. Address Mapping

The function parameters, control parameters and status parameters are all mapped as MODBUS's read-write register.

Function code address mapping

Their Group numbers are mapped as higher bytes of register address while the relationships are shown as below table.

The interGroup indexes are mapped as lower bytes. Please refer to user manual for index of F00 - F20 and U00.

High bytes of register address	Group number	High bytes of register address	Group number	High bytes of register address	Group number
0x00	F00	0x07	F07	0x10	F16
0x01	F01	0x08	F08	0x11	F17
0x02	F02	0x09	F09	0x12	F18
0x03	F03	0x0a	F10	0x13	F19
0x04	F04	0x0b	F11	0x14	F20
0x05	F05	0x0d	F13	0x14	F21
0x06	F06	0x0f	F15	0x17	F23
				0x18	U00

For instance: The register address of function parameter F03.02 is 0x0302, and that of function parameter F16.01 is 0x1001.

Control parameter (0x32) address mapping

The users can realize the inverter's starting, stopping and running speed setting through the control parameter, and obtain the inverter's running frequency, output current, etc. through indexing the inverter's status parameters.

The status parameters (0x32) are mapped as higher bytes of the register address, and the inter group indexes are as following:

Register address	Parameter name	Retained or not at power loss
0x3200	Control command character	No
0x3201	Running frequency setting	Saving or not is set by hundreds bit of F00.14 in power failure
0x3202	Auxiliary running frequency setting	No
0x3204	Virtual terminal control setting	No

Definition of inverter control command words (0x3200):

Bit	Value and definition		Function description
Bit0	0: Run command disabled	1: Run command enabled	To control the inverter's starting and stop (in edge triggering mode)
Bit1	0: Forward	1: Reverse	Running direction: have the same function as terminal FWD / REV
Bit2	0: Unused	1: Stop mode: Dec. to stop	Dec. to stop the inverter (in edge triggering mode)
Bit3	0: Unused	1: Stop mode: emergency to stop	Emergency to stop the inverter (in edge triggering mode)
Bit4	0: Unused	1: Stop mode: coast to stop	Coast to stop the inverter (in edge triggering mode)
Bit5	0: Unused	1: Stop mode: external fault	The inverter is displaying external fault, and will stop in accordance with F17.08 setting mode or continue to run
Bit6	0: Jog forward stop	1: Jog forward run	Jog forward control
Bit7	0: Jog reverse stop	1: Jog reverse run	Jog reverse control
Bit8	0: Fault reset disabled	1: Fault reset enabled	Fault reset control
Bit9 - Bit11	0: Unused		
Bit12	0: Present control disa	1: Present control enabled	The present sending control word is valid
Bit13 - Bit15	0: Unused		

The contents of the register can be defined as control commands as shown in the table below, ie the control command word bit logic combination.

Register content	Control command	Register address	Parameter name
0x1001	Forward running	0x1020	Stop due to external fault
0x1003	Reverse running	0x1040	Forward jog
0x1004	Dec. to stop	0x1080	Reverse jog
0x1008	Emergency to stop	0x1100	Fault reset
0x1010	Coast to stop		

Definition of virtual terminal control setting word (0x3204):

Bit	Value and definition	
Bit0	0: DO1 output is disabled	1: DO1 output is enabled
Bit1	0: DO2 output is disabled	1: DO2 output is enabled
Bit2	0: RLY1 output is disabled	1: RLY1 output is enabled
Bit3	0: RLY2 output is disabled	1: RLY2 output is enabled
Bit4	0: RLY3 output is disabled	1: RLY3 output is enabled
Bit5	0: RLY4 output is disabled	1: RLY4 output is enabled
Bit6 - Bit15	Unused	

Status parameter (0x33) address mapping

The status parameters (0x33) are mapped as higher bytes of the register address, and the inter group indexes are as following:

Address	Function	Address	Function
0x3300	Controller series	0x331F	Al3 voltage
0x3301	Software version of DSP	0x3320	Al3 voltage (after calculating)
0x3303	Special software version of DSP	0x3321	Al4 voltage
0x3305	Software version of keypad	0x3322	Al4 voltage (after calculating)
0x3306	Custom series No.	0x3323	DI6 terminal pulse input frequency
0x3307	Motor and control mode	0x3324	AO1 output
0x3308	Rated current of HD30	0x3325	AO2 output
0x330A	Inverter status	0x3326	High-speed output pulse frequency
0x330B	Master setting frequency source	0x3327	Heatsink temperature
0x330C	Master setting frequency	0x332C	Process PID reference
0x330D	Auxiliary setting frequency	0x332D	Process PID feedback
0x330E	Setting frequency	0x332E	Process PID error
0x330F	Reference frequency (after Acc. / Dec.)	0x332F	Process PID integral
0x3310	Output frequency	0x3330	Process PID output
0x3311	Setting Rpm	0x3331	External counting value
0x3312	Running Rpm	0x3332	Input terminal status
0x3314	Output voltage	0x3333	Output terminal status
0x3315	Output current	0x3334	MODBUS communication status
0x3316	Setting torque	0x3335	Actual length
0x3317	Output torque	0x3336	Total length
0x3318	Output power	0x3337	Total time at power on (hour)
0x3319	DC bus voltage	0x3338	Total time at running (hour)
0x331A	Input voltage of keypad of potentiometer	0x3339	High byte of motor total energy
0x331B	Al1 voltage	0x333A	Low byte of motor total energy
0x331C	Al1 voltage (after calculating)	0x333B	High byte of this running energy
0x331D	Al2 voltage	0x333C	Low byte of this running energy
0x331E	Al2 voltage (after calculating)	0x333D	The present fault code

5. Special Instruction

- Group F08 (Asyn. motor 1 parameter setting), Group F12 (Unused), F13.00 - F13.15 (Asyn. motor 2 parameter setting) and Group F17 (SCI communication parameters) are the inverter parameter which can be read but cannot be modified by the host computer.
- F01.00 (user password) cannot be set and adjusted through communication as well, but the user can verify the user password by writing F01.00 and get access to adjust inverter function parameters on the host. After adjustment, the user can close the permission by writing invalid password to F01.00.
- If many multi-function input terminals are set the same function, it may cause dysfunction. Therefore, the user should avoid this case when modify the multi-function terminal function via the MODBUS.

6. CRC Checking

Code of online calculating CRC is shown below:

```
unsigned int crc_check(unsigned char *data,unsigned char length)
{
    int i;
    unsigned crc_result=0xffff;
    while(length--)
    {
        crc_result^=*data++;
        for(i=0;i<8;i++)
        {
            if(crc_result&0x01)
                crc_result=(crc_result>>1)^0xa001;
            else
                crc_result=crc_result>>1;
        }
    }
    return (crc_result=((crc_result&0xff)<<8)|(crc_result>>8));
}
```

7. Application Case

Remarks: Please verify all the hardware equipments are connected well before controlling the inverter via communication. In addition, please preset the communication data format, baud rate and communication address.

1. To read the command frame of the max. output frequency of slave 2 (to read F00.06), answer 50.00Hz.

Command frame	Address	Code	Register address		Word no. of read		Checksum	
	0x02	0x03	0x00	0x06	0x00	0x01	0x64	0x38
Response frame	Address	Code	Answer byte		Register content		Checksum	
	0x02	0x03	0x02		0x13	0x88	0xF1	0x12

2. To read the DC bus voltage of slave 2 (to read status parameter), answer 537V.

Command frame	Address	Code	Register address		Word no. of read		Checksum	
	0x02	0x03	0x33	0x19	0x00	0x01	0x5A	0xBA
Response frame	Address	Code	Answer byte		Register content		Checksum	
	0x02	0x03	0x02		0x02	0x19	0x3C	0xEE

3. To read the setting frequency of slave 2 (set F00.13 to 45.00Hz).

Command frame	Address	Code	Register address		Register content		Checksum	
	0x02	0x06	0x00	0x0D	0x11	0x94	0x15	0xC5
Response frame	Address	Code	Register address		Register content		Checksum	
	0x02	0x06	0x00	0x0D	0x11	0x94	0x15	0xC5

4. When the frequency setting source F00.10 = 2, set the frequency value to 45.00Hz by writing the register content 0x11, 0x94.

Command frame	Address	Code	Register address		Register content		Checksum	
	0x02	0x06	0x32	0x01	0x11	0x94	0xDB	0x7E
Response frame	Address	Code	Register address		Register content		Checksum	
	0x02	0x06	0x32	0x01	0x11	0x94	0xDB	0x7E

5. F00.11 = 2, give the reverse operation command to the address 2 of slave.

Command frame	Address	Code	Register address		Register content		Checksum	
	0x02	0x06	0x32	0x00	0x10	0x03	0xCA	0x80
Response frame	Address	Code	Register address		Register content		Checksum	
	0x02	0x06	0x32	0x00	0x10	0x03	0xCA	0x80

6. F00.11 = 2, give the Dec. stop command to the address 2 of slave.

Command frame	Address	Code	Register address		Register content		Checksum	
	0x02	0x06	0x32	0x00	0x10	0x04	0x8B	0x42
Response frame	Address	Code	Register address		Register content		Checksum	
	0x02	0x06	0x32	0x00	0x10	0x04	0x8B	0x42

7. F00.11 = 2, give the emergency stop command to the address 2 of slave.

Command frame	Address	Code	Register address		Register content		Checksum	
	0x02	0x06	0x32	0x00	0x10	0x08	0x8B	0x42
Response frame	Address	Code	Register address		Register content		Checksum	
	0x02	0x06	0x32	0x00	0x10	0x08	0x8B	0x42

8. F00.11 = 2, give the coast to stop command to the address 2 of slave.

Command frame	Address	Code	Register address		Register content		Checksum	
	0x02	0x06	0x32	0x00	0x10	0x10	0x8B	0x4D
Response frame	Address	Code	Register address		Register content		Checksum	
	0x02	0x06	0x32	0x00	0x10	0x10	0x8B	0x4D

9. External fault stop control of slave 2 via communication (E0024 fault).

Command frame	Address	Code	Register address		Register content		Checksum	
	0x02	0x06	0x32	0x00	0x10	0x20	0x8B	0x59
Response frame	Address	Code	Register address		Register content		Checksum	
	0x02	0x06	0x32	0x00	0x10	0x20	0x8B	0x59

10. Give the fault reset signal to the address 2 of slave.

Command	Address	Code	Register address		Register content		Checksum	
frame	0x02	0x06	0x32	0x00	0x11	0x00	0x8B	0x11
Response	Address	Code	Register address		Register content		Checksum	
frame	0x02	0x06	0x32	0x00	0x11	0x00	0x8B	0x11