

Vision Accessories

Light units, Lighting controllers and Lenses



- Complete line-up for lighting and lenses
- Camera-mount strobe controllers
- Robust design for vibration and shock resistance

Support for High-precision Inspection and Control

Vision Accessory Lineup

Light Units

Standard Models

FLV Series

NEW

Light Series
Approx.
200 Models

Direct Ring Light/
Low Angle Ring Light



Bar Light



Coaxial Light



Edge Type Light



Edge Type Coaxial Light



Direct Back Light

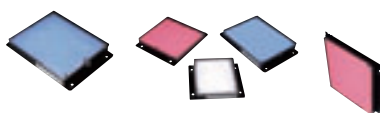

Dome Light



Shadowless Light



Spot Light



Line Light

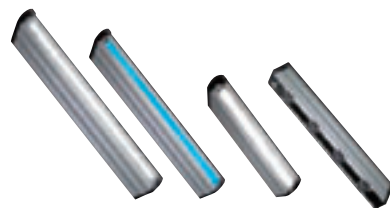

Vision Sensors



High-brightness
Models



FL Series

Direct Ring Light



Bar Light



With our complete Light and Lens lineup, solutions knowhow, and advanced Vision Sensors, OMRON provides propriety solutions to maintain the quality of your products and increase the precision of your machines.

Lighting Controllers

Standard Models for FLV Series

Camera-mount
Lighting Controller



Analog Lighting
Controller



High-brightness Models for FL Series

Camera-mount Lighting
Controller



Digital Lighting
Controller



Lenses

Standard Lens



Vibrations and Shocks
Resistant C-mount Lens

NEW



High-resolution,
Low-distortion Lens



CONTENTS

Lights Standard Models	FLV Series	NEW
Direct Ring Light/Low Angle Ring Light FLV-DR Series/-DL Series		4
Bar Light FLV-BR Series		8
Coaxial Light FLV-CL Series		11
Shadowless Light FLV-FS Series		13
Shadowless Light FLV-FR Series		14
Shadowless Light FLV-FP Series		16
Shadowless Light FLV-FQ Series		17
Direct Back Light FLV-DB Series		18
Edge Type Light FLV-FB Series		20
Edge Type Coaxial Light FLV-FX Series		22
Dome Light FLV-DD Series		24
High-power Spot Light FLV-EP08 Series		26
Spot Light FLV-EP50 Series		28
Line Light FLV-LN Series		29
Camera-mount Lighting Controller for FLV Series FLV-TCC Series		31
Analog Lighting Controller for FLV Series FLV-ATC Series		34
Lights High-brightness Models	FL Series	
Direct Ring Light FL-DR Series		39
Bar Light FL-BR Series		42
Digital Lighting Controller for FL Series FL-STC Series		45
Camera-mount Lighting Controller for FL Series FL-TCC Series		48
Options		50
Lenses	NEW	54
LED Characteristics		62

Direct Ring Light/Low Angle Ring Light FLV-DR Series/-DL Series

Select Lighting that fits your workpieces with a variety of illumination angles.

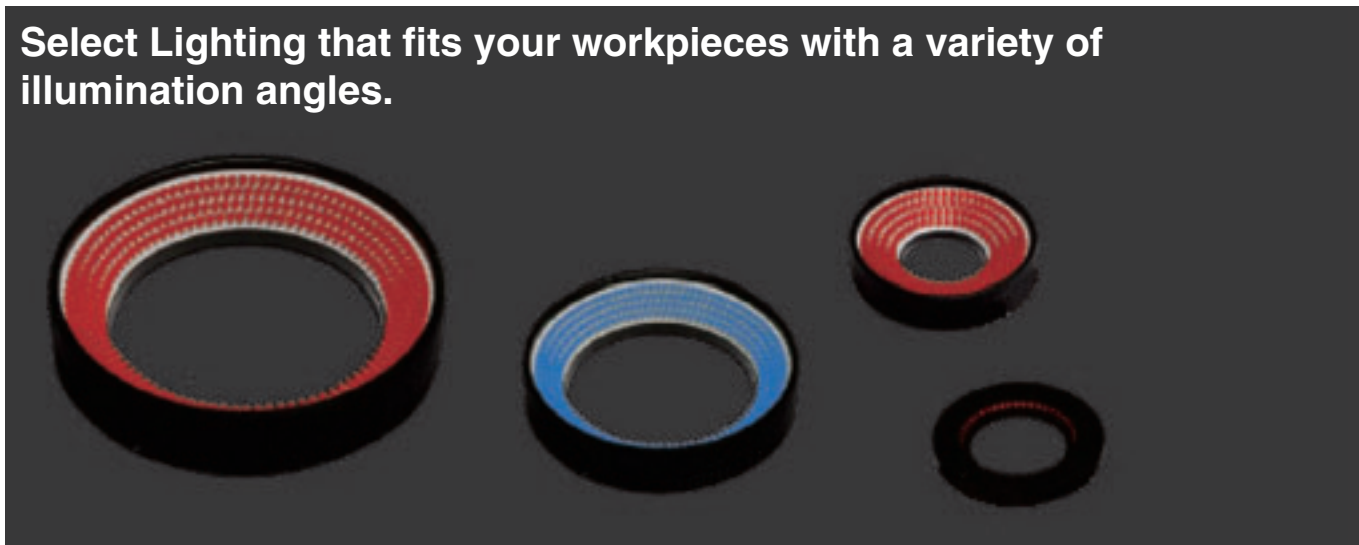

Product Features

- Bright illumination with high-density LED arrays.
- Compact designs that save installation space.
- Optional Diffusion Plates for uniform illumination.

Applications

- Detection of PCBs
- Detection of IC components
- Microscope illumination
- Detection of plastic containers
- Inspection of printing on ICs
- Standard exterior detection, character recognition, and code reading

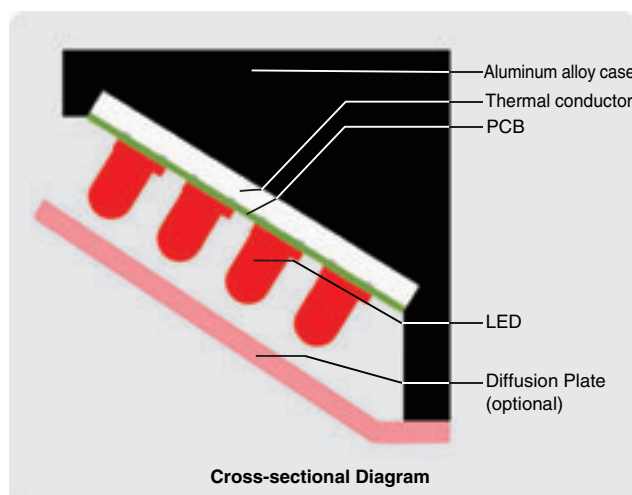

*: This figure is a conceptual illustration and may vary from the actual structure.

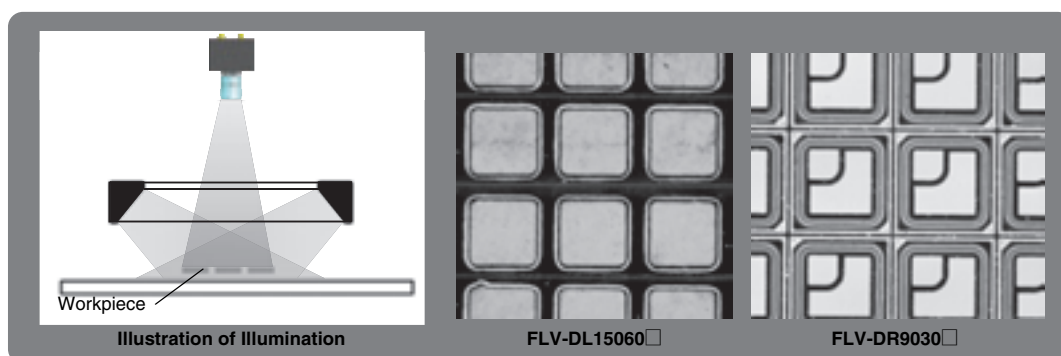

Ordering Information

	Model	Light Color	Power consumption (W)	Weight (g)	Available Option		Connectable Lighting Controller *1		Dimension
					Diffusion Plate	Polarization Plate	Camera-mount Lighting Controller FLV-TCC Series #2	Analog Lighting Controller FLV-ATC Series	
Direct Ring Light	FLV-DR3220W	White	1.4	60	FLV-DR3220DF	FLV-DR3220PL	○	○	A
	FLV-DR3220R	Red	1.3	60	FLV-DR3220DF	FLV-DR3220PL	○	○	A
	FLV-DR3220B	Blue	1.4	60	FLV-DR3220DF	FLV-DR3220PL	○	○	A
	FLV-DR5030W	White	3.1	60	FLV-DR5030DF	FLV-DR5030PL	○	○	B
	FLV-DR5030R	Red	1.8	60	FLV-DR5030DF	FLV-DR5030PL	○	○	B
	FLV-DR5030B	Blue	3.1	60	FLV-DR5030DF	FLV-DR5030PL	○	○	B
	FLV-DR5030IR	Infrared	1.3	60	FLV-DR5030DF	FLV-DR5030PL	○	○	B
	FLV-DR6030UV	Ultraviolet	3.2	90	FLV-DR6030DF	-	○	○	O
	FLV-DR6615W	White	5.0	120	FLV-DR6615DF	FLV-DR6615PL	○	○	C
	FLV-DR6615R	Red	3.9	120	FLV-DR6615DF	FLV-DR6615PL	○	○	C
	FLV-DR6615B	Blue	5.0	120	FLV-DR6615DF	FLV-DR6615PL	○	○	C
	FLV-DR7000W	White	5.0	110	FLV-DR7000DF	FLV-DR7000PL	○	○	D
	FLV-DR7000R	Red	3.7	110	FLV-DR7000DF	FLV-DR7000PL	○	○	D
	FLV-DR7000B	Blue	5.0	110	FLV-DR7000DF	FLV-DR7000PL	○	○	D
	FLV-DR7030W	White	5.0	120	FLV-DR7030DF	FLV-DR7030PL	○	○	E
	FLV-DR7030R	Red	3.7	120	FLV-DR7030DF	FLV-DR7030PL	○	○	E
	FLV-DR7030B	Blue	5.0	120	FLV-DR7030DF	FLV-DR7030PL	○	○	E
	FLV-DR7030IR	Infrared	2.6	120	FLV-DR7030DF	FLV-DR7030PL	○	○	E
	FLV-DR7530UV	Ultraviolet	5.4	150	FLV-DR7530DF	-	○	○	P
	FLV-DR9000W	White	8.8	230	FLV-DR9000DF	FLV-DR9000PL	○	○	F
	FLV-DR9000R	Red	7.0	230	FLV-DR9000DF	FLV-DR9000PL	○	○	F
	FLV-DR9000B	Blue	8.8	230	FLV-DR9000DF	FLV-DR9000PL	○	○	F
	FLV-DR9030W	White	8.1	200	FLV-DR9030DF	FLV-DR9030PL	○	○	G
	FLV-DR9030R	Red	6.6	200	FLV-DR9030DF	FLV-DR9030PL	○	○	G
	FLV-DR9030B	Blue	8.1	200	FLV-DR9030DF	FLV-DR9030PL	○	○	G
	FLV-DR9030IR	Infrared	4.3	200	FLV-DR9030DF	FLV-DR9030PL	○	○	G
	FLV-DR9030UV	Ultraviolet	6.8	220	FLV-DR9030DF	-	○	○	Q
	FLV-DR9215W	White	7.4	200	FLV-DR9215DF	FLV-DR9215PL	○	○	H
	FLV-DR9215R	Red	5.4	200	FLV-DR9215DF	FLV-DR9215PL	○	○	H
	FLV-DR9215B	Blue	7.4	200	FLV-DR9215DF	FLV-DR9215PL	○	○	H
FLV-DR12030W	White	11.9	360	FLV-DR12030DF	FLV-DR12030PL	○	○	I	
FLV-DR12030R	Red	9.8	360	FLV-DR12030DF	FLV-DR12030PL	○	○	I	
FLV-DR12030B	Blue	11.9	360	FLV-DR12030DF	FLV-DR12030PL	○	○	I	
Low Angle Ring Light	FLV-DL5890W	White	1.9	90	FLV-DL5890DF	-	○	○	J
	FLV-DL5890R	Red	1.3	90	FLV-DL5890DF	-	○	○	J
	FLV-DL5890B	Blue	1.9	90	FLV-DL5890DF	-	○	○	J
	FLV-DL7260W	White	5.7	120	FLV-DL7260DF	FLV-DL7260PL	○	○	K
	FLV-DL7260R	Red	3.9	120	FLV-DL7260DF	FLV-DL7260PL	○	○	K
	FLV-DL7260B	Blue	5.7	120	FLV-DL7260DF	FLV-DL7260PL	○	○	K
	FLV-DL9090W	White	2.8	100	-	-	○	○	L
	FLV-DL9090R	Red	1.8	100	-	-	○	○	L
	FLV-DL9090B	Blue	2.8	100	-	-	○	○	L
	FLV-DL12060W	White	12.7	310	FLV-DL12060DF	FLV-DL12060PL	○	○	M
	FLV-DL12060R	Red	10.5	310	FLV-DL12060DF	FLV-DL12060PL	○	○	M
	FLV-DL12060B	Blue	12.7	310	FLV-DL12060DF	FLV-DL12060PL	○	○	M
	FLV-DL15060W	White	13.6	260	FLV-DL15060DF	FLV-DL15060PL	○	○	N
	FLV-DL15060R	Red	11.2	260	FLV-DL15060DF	FLV-DL15060PL	○	○	N
	FLV-DL15060B	Blue	13.6	260	FLV-DL15060DF	FLV-DL15060PL	○	○	N

*1: The table shows whether each Light can be connected to Lighting Controllers. When multiple Lights are connected to a Lighting Controller, make sure that the total power consumption of all connected Lights does not exceed the power consumption of connectable Light of each Lighting Controller.

- ◎: Connectable. Light can be continuously powered.
- : Connectable. Light can be powered only while the trigger is input.
- X: Not connectable

*2: If the Lighting requires more than 7.5 W of total power, an external power supply to the FLV-TCC is required.

Note: Refer to page 62 for LED Characteristics.

Direct Ring Light/Low Angle Ring Light FLV-DR Series/-DL Series

Dimensions (Unit: mm)

●Direct Ring Light

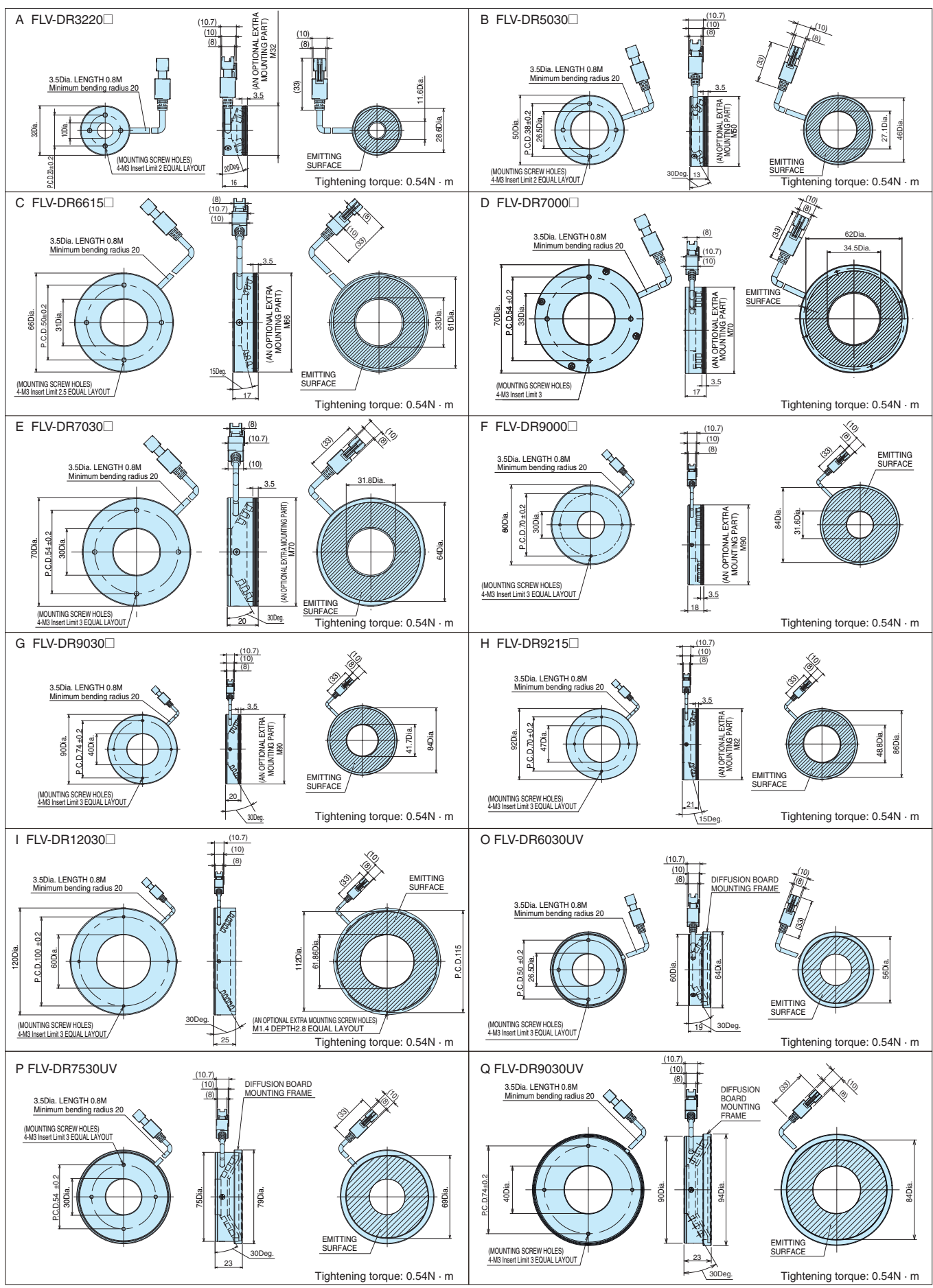

●Low Angle Ring Light

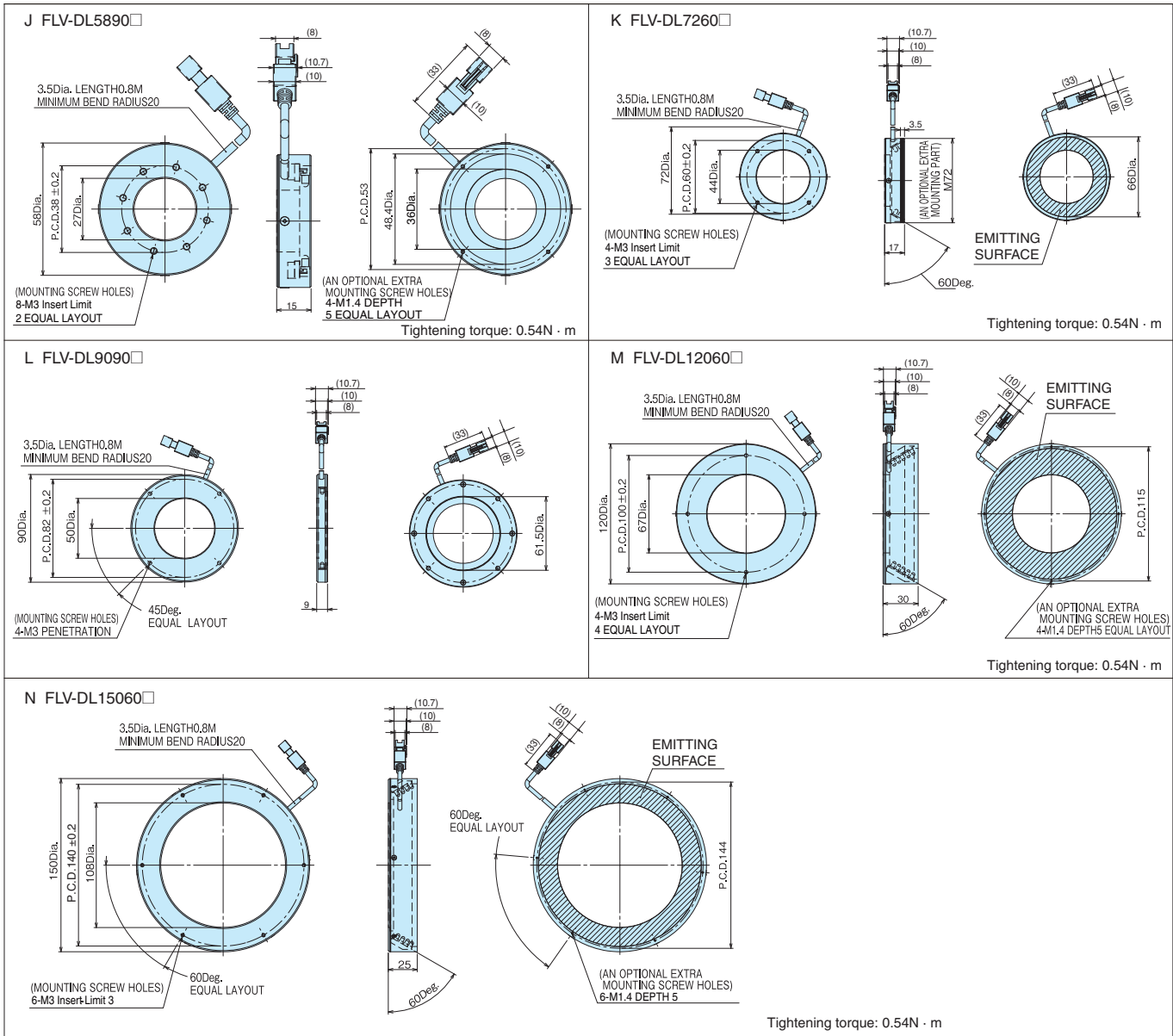

Bar Light FLV-BR Series

Many color and size variations are available to uniformly illuminate wide surfaces.

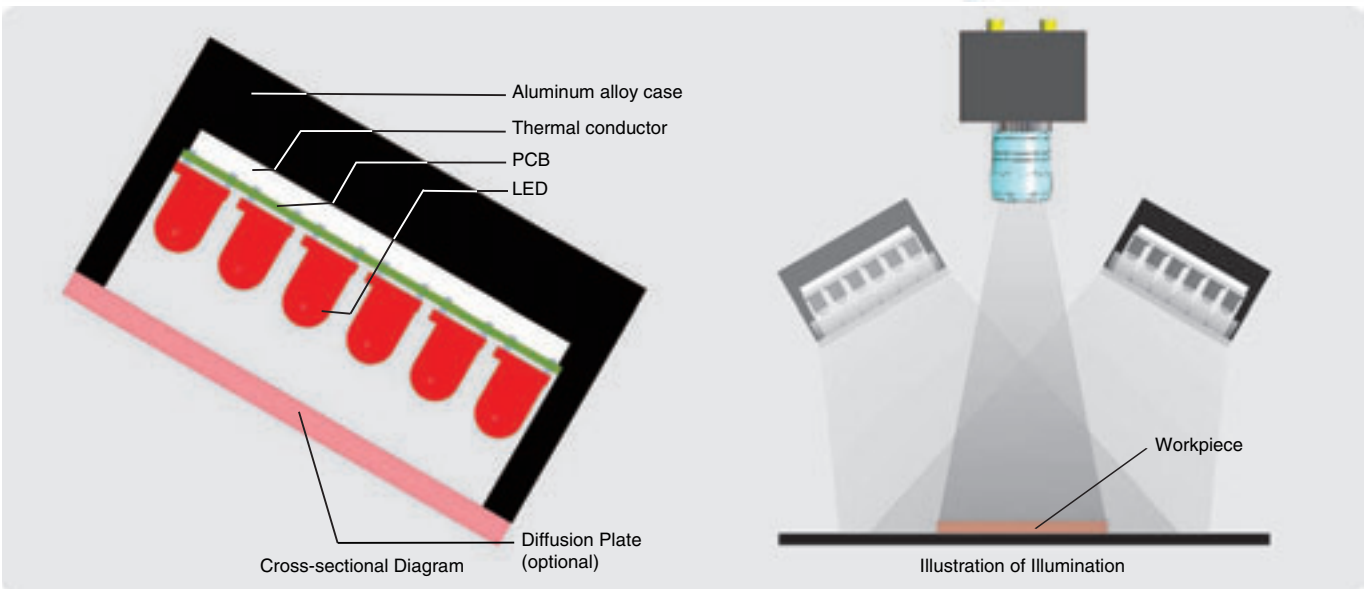

*: This figure is a conceptual illustration and may vary from the actual structure.

Product Features

- Ideal for illumination of wide, rectangular surfaces.
- Many color and size variations.

Applications

- Detection of metal surfaces
- Image scanning
- Detection of cracks on surfaces
- Detection of LCD panels



Positioning of LED Packages



Detection of Faulty LGA Electrodes



Detection of Printed Logo Marks and Characters on Long Workpieces

Ordering Information

Model	Light Color	Power consumption (W)	Weight (g)	Applicable Option		Connectable Lighting Controller *1		Dimension
				Diffusion Plate	Polarization Plate*3	Camera-mount Lighting Controller FLV-TCC Series*2	Analog Lighting Controller FLV-ATC Series	
FLV-BR6022W	White	1.4	60	FLV-BR6022DF	FLV-BR6022PL-□	○	○	A
FLV-BR6022R	Red	1.3	60	FLV-BR6022DF	FLV-BR6022PL-□	○	○	A
FLV-BR6022B	Blue	1.4	60	FLV-BR6022DF	FLV-BR6022PL-□	○	○	A
FLV-BR6022IR	Infrared	0.9	60	FLV-BR6022DF	FLV-BR6022PL-□	○	○	A
FLV-BR6424UV	Ultraviolet	1.8	70	FLV-BR6424DF	-	○	○	J
FLV-BR8532W	White	3.5	130	FLV-BR8532DF	FLV-BR8532PL-□	○	○	B
FLV-BR8532R	Red	3.1	130	FLV-BR8532DF	FLV-BR8532PL-□	○	○	B
FLV-BR8532B	Blue	3.5	130	FLV-BR8532DF	FLV-BR8532PL-□	○	○	B
FLV-BR11222W	White	4.2	100	FLV-BR11222DF	FLV-BR11222PL-□	○	○	C
FLV-BR11222R	Red	2.6	100	FLV-BR11222DF	FLV-BR11222PL-□	○	○	C
FLV-BR11222B	Blue	4.2	100	FLV-BR11222DF	FLV-BR11222PL-□	○	○	C
FLV-BR11222IR	Infrared	1.8	100	FLV-BR11222DF	FLV-BR11222PL-□	○	○	C
FLV-BR11624UV	Ultraviolet	3.6	120	FLV-BR11624DF	-	○	○	K
FLV-BR14030W	White	6.1	140	FLV-BR14030DF	FLV-BR14030PL-□	○	○	D
FLV-BR14030R	Red	4.8	140	FLV-BR14030DF	FLV-BR14030PL-□	○	○	D
FLV-BR14030B	Blue	6.1	140	FLV-BR14030DF	FLV-BR14030PL-□	○	○	D
FLV-BR15020W	White	5.5	120	FLV-BR15020DF	FLV-BR15020PL-□	○	○	E
FLV-BR15020R	Red	3.1	120	FLV-BR15020DF	FLV-BR15020PL-□	○	○	E
FLV-BR15020B	Blue	5.5	120	FLV-BR15020DF	FLV-BR15020PL-□	○	○	E
FLV-BR21222W	White	8.7	140	FLV-BR21222DF	FLV-BR21222PL-□	○	○	F
FLV-BR21222R	Red	5.0	140	FLV-BR21222DF	FLV-BR21222PL-□	○	○	F
FLV-BR21222B	Blue	8.7	140	FLV-BR21222DF	FLV-BR21222PL-□	○	○	F
FLV-BR21230W	White	8.8	220	FLV-BR21230DF	FLV-BR21230PL-□	○	○	G
FLV-BR21230R	Red	7.0	220	FLV-BR21230DF	FLV-BR21230PL-□	○	○	G
FLV-BR21230B	Blue	8.8	220	FLV-BR21230DF	FLV-BR21230PL-□	○	○	G
FLV-BR21230IR	Infrared	6.1	220	FLV-BR21230DF	FLV-BR21230PL-□	○	○	G
FLV-BR21230UV	Ultraviolet	7.8	230	FLV-BR21230DF	-	○	○	L
FLV-BR38037W	White	15.9	430	FLV-BR38037DF	FLV-BR38037PL-□	×	○	H
FLV-BR38037R	Red	11.3	430	FLV-BR38037DF	FLV-BR38037PL-□	○	○	H
FLV-BR38037B	Blue	15.9	430	FLV-BR38037DF	FLV-BR38037PL-□	×	○	H
FLV-BR48031W	White	21.9	460	FLV-BR48031DF	FLV-BR48031PL-□	×	○	I
FLV-BR48031R	Red	18.0	460	FLV-BR48031DF	FLV-BR48031PL-□	×	○	I
FLV-BR48031B	Blue	21.9	460	FLV-BR48031DF	FLV-BR48031PL-□	×	○	I

*1: The table shows whether each Light can be connected to Lighting Controllers. When multiple Lights are connected to a Lighting Controller, make sure that the total power consumption of all connected Lights does not exceed the power consumption of connectable Light of each Lighting Controller.

- ◎: Connectable. Light can be continuously powered.
- : Connectable. Light can be powered only while the trigger is input.
- ×: Not connectable

*2: If the Lighting requires more than 7.5 W of total power, an external power supply to the FLV-TCC is required.

*3: There are different model numbers for different polarization directions.

Polarization along the short direction: The model numbers have a “-V” suffix. (Example: FLV-BR□□□□□PL-V)

Polarization along the long direction: The model numbers do not have a “-V” suffix. (Example: FLV-BR□□□□□PL)

Note: Refer to page 62 for LED Characteristics.

Bar Light FLV-BR Series

Dimensions (Unit: mm)

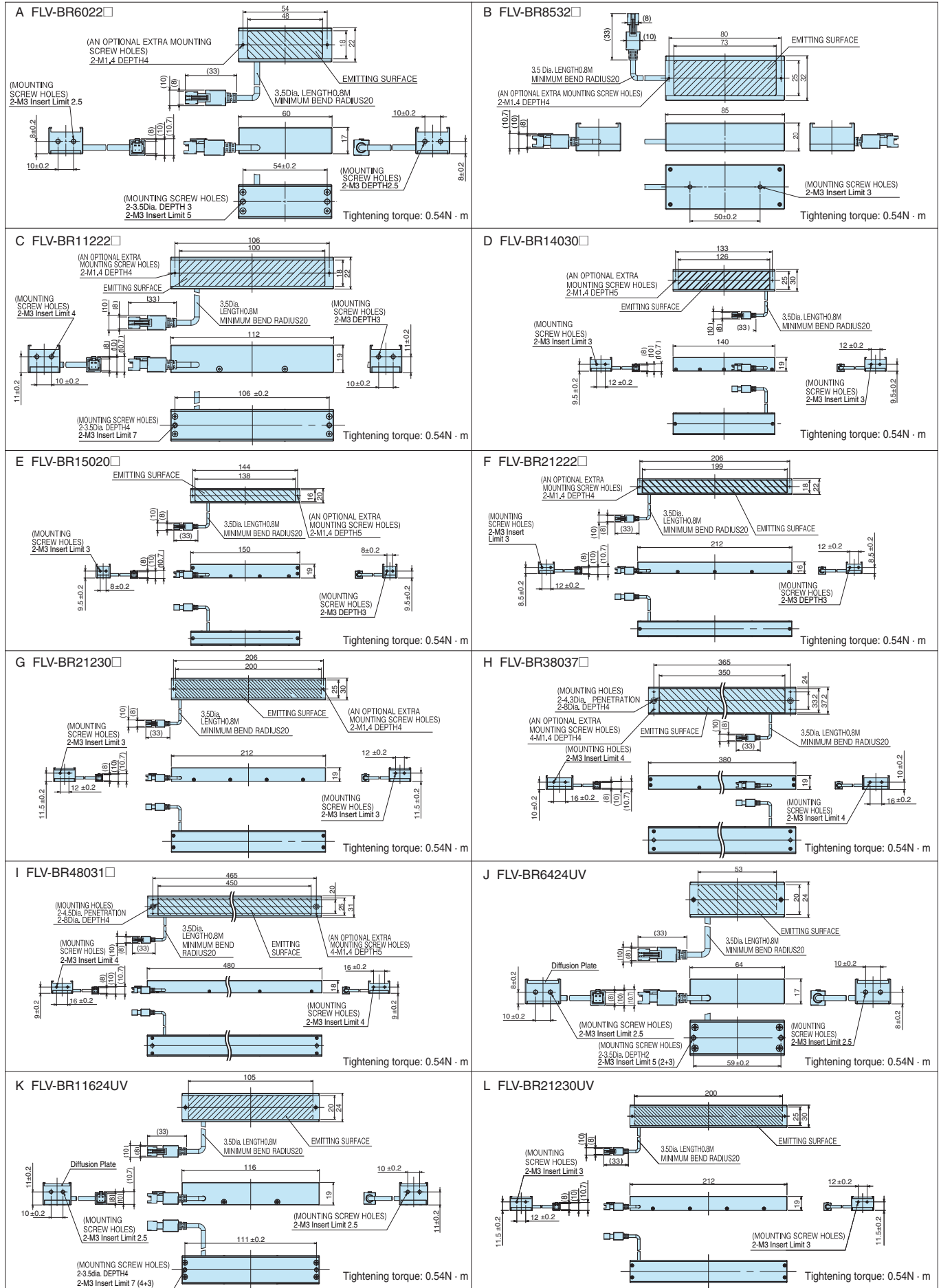

Coaxial Light FLV-CL Series

Coaxial illumination with the Lens helps prevent interference from reflected light. This series is ideal for surface damage and character inspections on highly reflective workpieces with mirror-like surfaces.

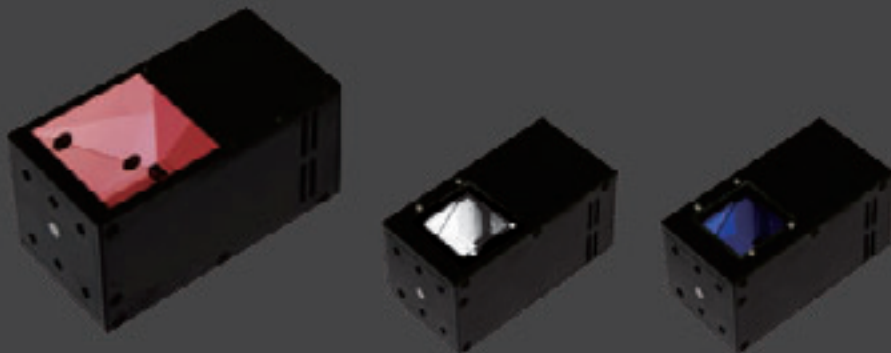

Product Features

- Long life and stability result from a structure with optimum heat dissipation.
- Uniform illumination for clear images.

Applications

- Inspection for scratches on highly reflective surfaces
- Inspection for damages on chips and silicon wafers
- Detection of positioning marks
- Recognition of bar codes on packages
- Recognition of laser-marked characters and 2D DMP codes
- General exterior detection

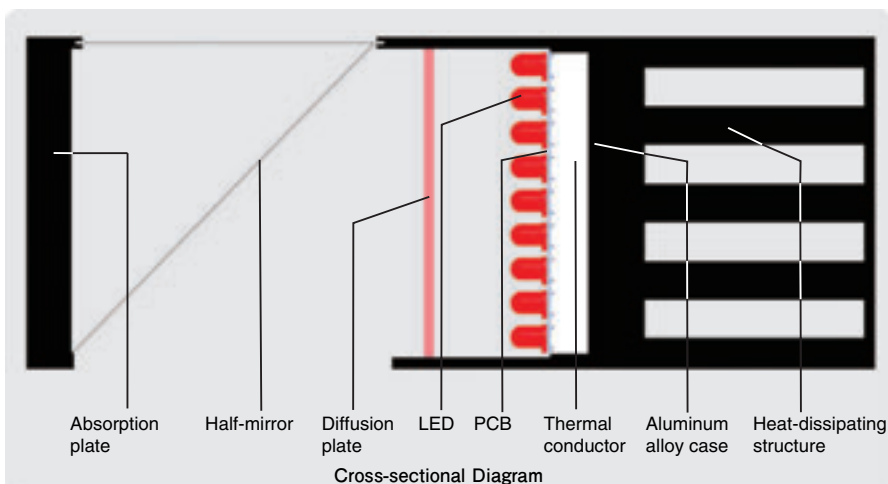

*: This figure is a conceptual illustration and may vary from the actual structure.

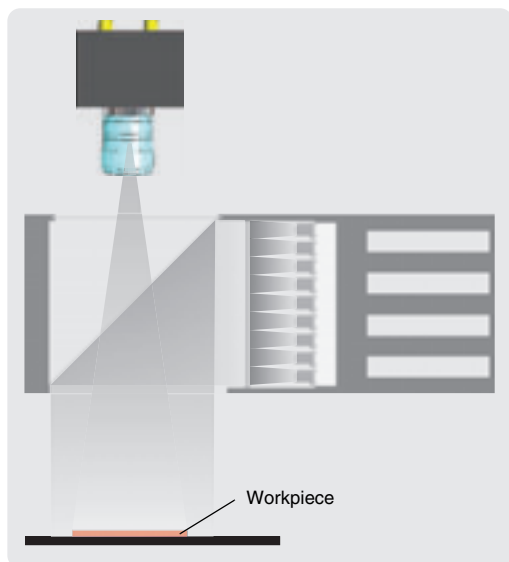
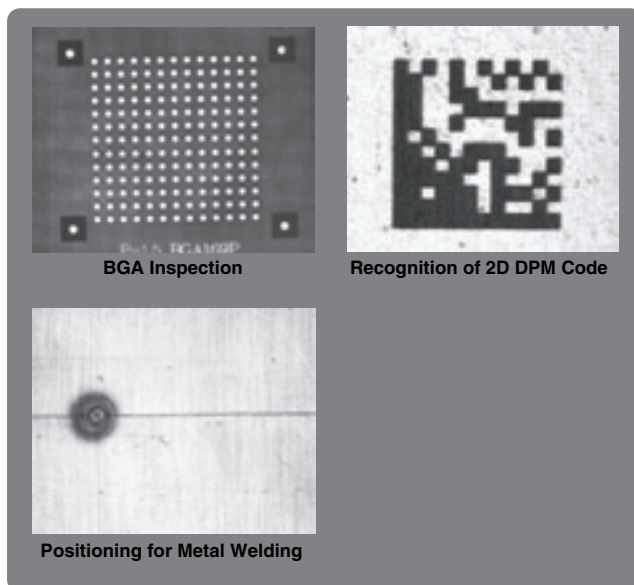

Illustration of Illumination



Coaxial Light FLV-CL Series

Ordering Information

Mode	Light Color	Power consumption (W)	Weight (g)	Connectable Lighting Controller *1		Dimension
				Camera-mount Lighting Controller FLV-TCC Series *2	Analog Lighting Controller FLV-ATC Series	
FLV-CL30W	White	2.4	110	○	○	A
FLV-CL30R	Red	1.4	110	○	○	A
FLV-CL30B	Blue	2.4	110	○	○	A
FLV-CL40W	White	3.9	170	○	○	B
FLV-CL40R	Red	2.3	170	○	○	B
FLV-CL40B	Blue	3.9	170	○	○	B
FLV-CL60W	White	10.4	380	○	○	C
FLV-CL60R	Red	5.7	380	○	○	C
FLV-CL60B	Blue	10.4	380	○	○	C
FLV-CL60IR	Infrared	3.9	380	○	○	C
FLV-CL60UV	Ultraviolet	3.0	380	○	○	C
FLV-CL80W	White	10.8	580	○	○	D
FLV-CL80R	Red	7.2	580	○	○	D
FLV-CL80B	Blue	10.8	580	○	○	D
FLV-CL100W	White	22.7	820	×	○	E
FLV-CL100R	Red	15.2	820	×	○	E
FLV-CL100B	Blue	22.7	820	×	○	E

*1: The table shows whether each Light can be connected to Lighting Controllers. When multiple Lights are connected to a Lighting Controller, make sure that the total power consumption of all connected Lights does not exceed the power consumption of connectable Light of each Lighting Controller.

○: Connectable. Light can be continuously powered. ○: Connectable. Light can be powered only while the trigger is input. X: Not connectable

*2: If the Lighting requires more than 7.5 W of total power, an external power supply to the FLV-TCC is required.
Note: Refer to page 62 for LED Characteristics.

Dimensions (Unit: mm)

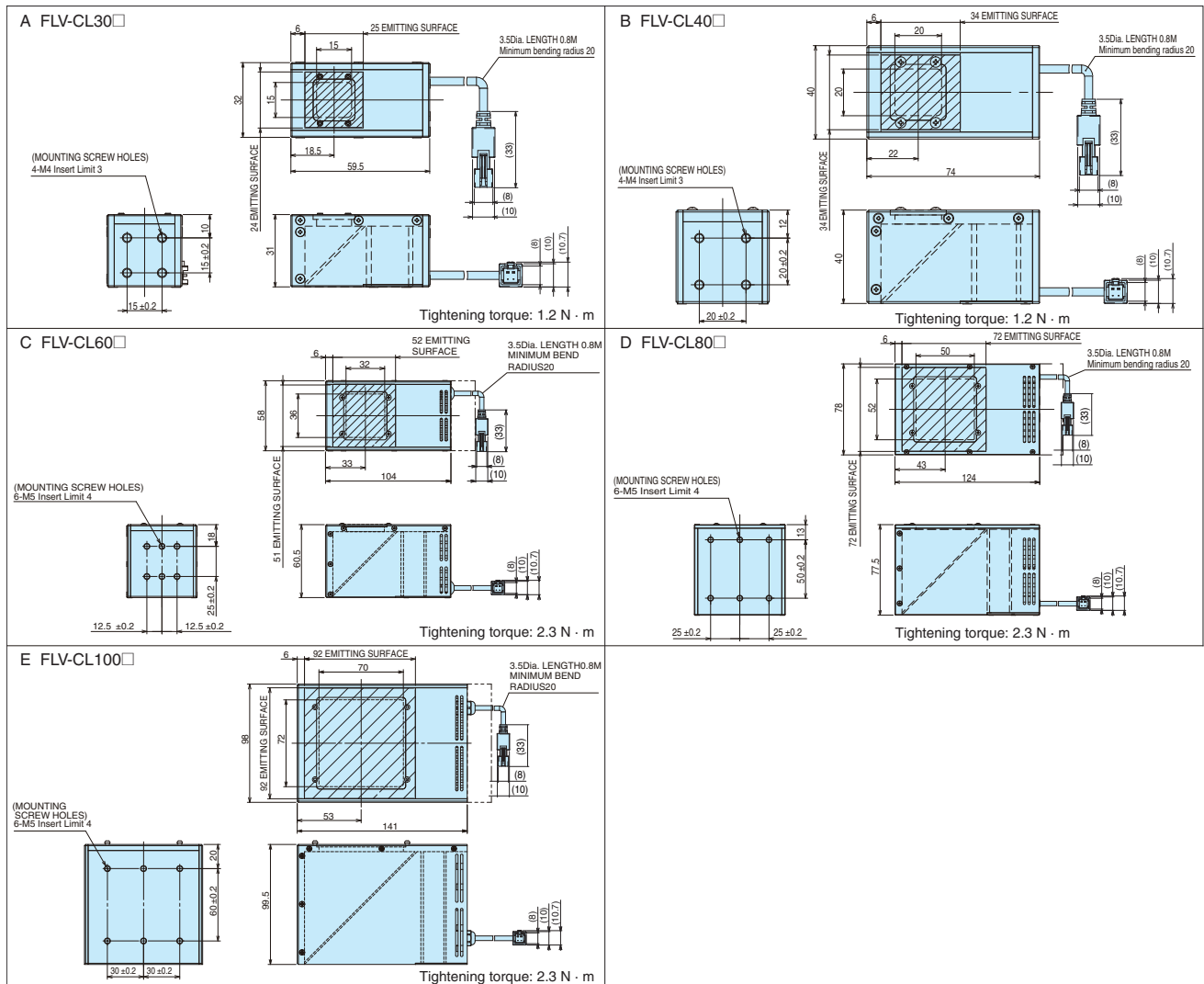

Shadowless Light FLV-FS Series

Diffused Dome Lighting

Highly uniform illumination eliminates the influences of small surface irregularities to highlight features through changes in inclination.



Product Features

- Uniquely designed diffusion plate achieve highly uniform illumination through reflection and diffusion.
- Eliminates the influences of small surface irregularities to highlight features through large differences in inclination.
- Saves space for small workpieces while achieving the benefits of dome lighting.

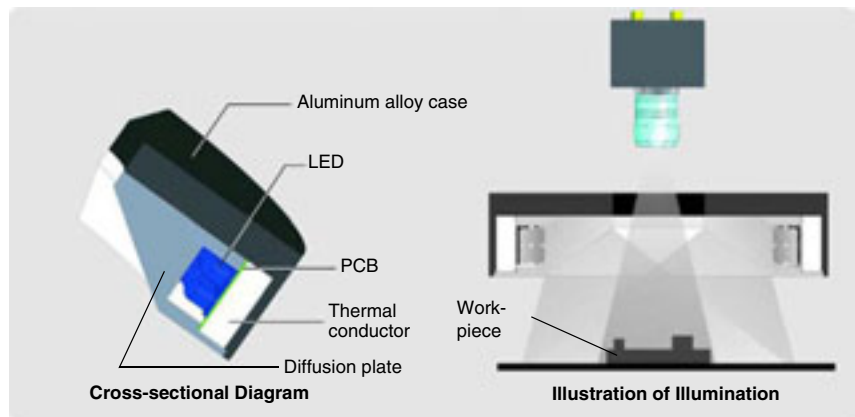

*: This figure is a conceptual illustration and may vary from the actual structure.

Applications

- Edge positioning and size measurement for metal parts
- Detection of bumps in metal parts



Ordering Information

Model	Light Color	Power consumption (W)	Weight (g)	Connectable Lighting Controller *1		Dimension
				Camera-mount Lighting Controller FLV-TCC Series *2	Analog Lighting Controller FLV-ATC Series	
FLV-FS74W	White	5.2	140	⊙	⊙	A
FLV-FS74R	Red	3.5	140	⊙	⊙	A
FLV-FS74B	Blue	5.2	140	⊙	⊙	A

*1: The table shows whether each Light can be connected to Lighting Controllers. When multiple Lights are connected to a Lighting Controller, make sure that the total power consumption of all connected Lights does not exceed the power consumption of connectable Light of each Lighting Controller.

⊙: Connectable. Light can be continuously powered. ○: Connectable. Light can be powered only while the trigger is input. X: Not connectable

*2: If the Lighting requires more than 7.5 W of total power, an external power supply to the FLV-TCC is required.

Note: Refer to page 62 for LED Characteristics.

Dimensions (Unit: mm)

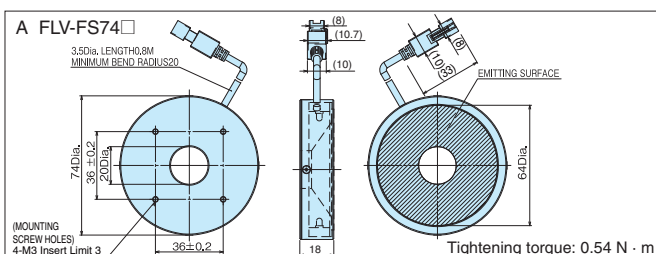

Shadowless Light FLV-FR Series

Diffused Ring Lighting

This series effectively eliminates the influences of localized reflections for the surfaces of small workpieces.

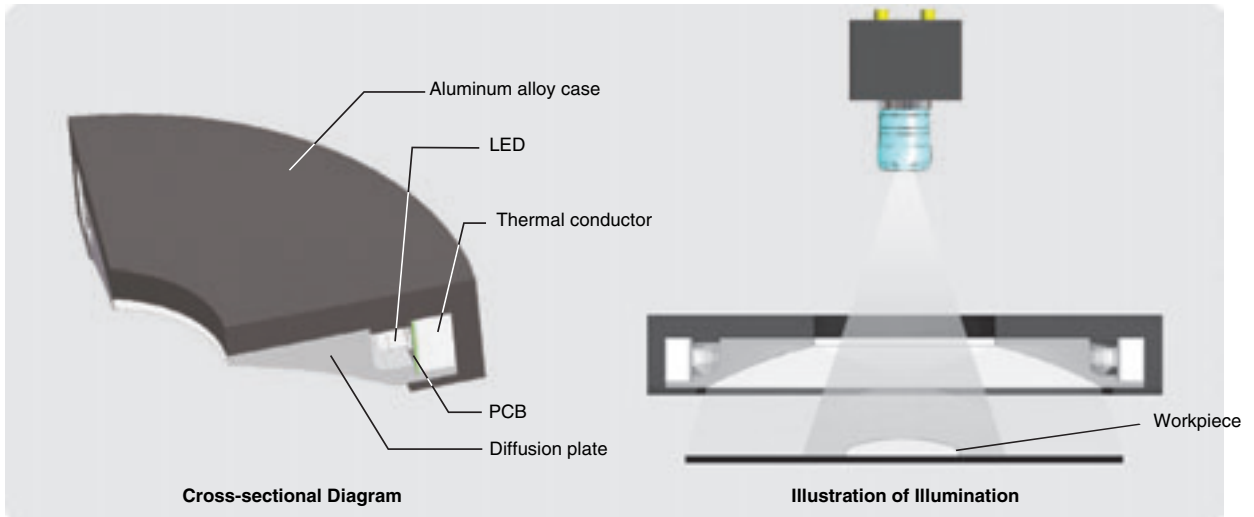
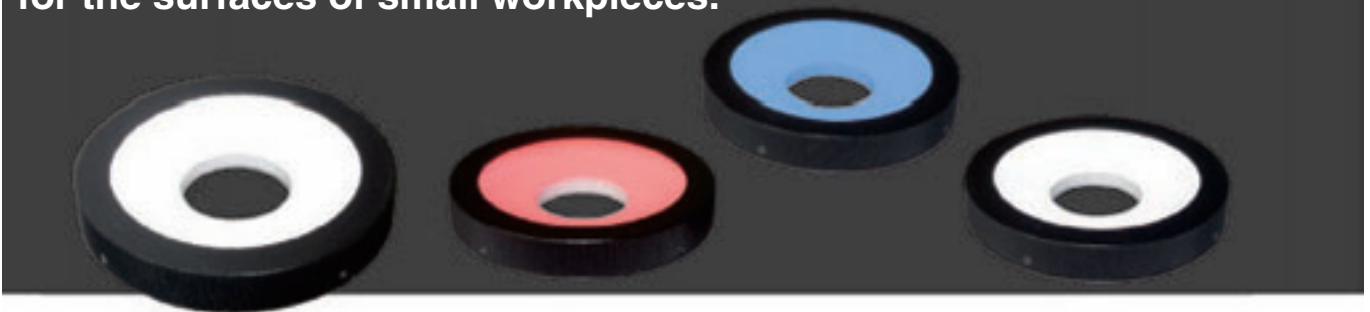

*: This figure is a conceptual illustration and may vary from the actual structure.

Product Features

- Special diffusion plates create greater uniformity in lighting than normal ring lighting.

Applications

- Character inspections on electronic components or formed plastic parts

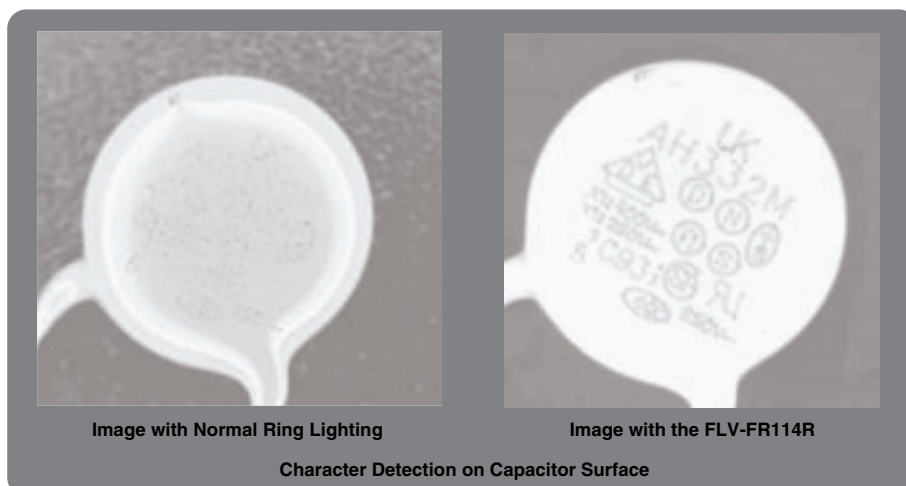

Ordering Information

Model	Light Color	Power consumption (W)	Weight (g)	Connectable Lighting Controller *1		Dimension
				Camera-mount Lighting Controller FLV-TCC Series *2	Analog Lighting Controller FLV-ATC Series	
FLV-FR114W	White	3.9	270	⊙	⊙	A
FLV-FR114R	Red	3.1	270	⊙	⊙	A
FLV-FR114B	Blue	3.9	270	⊙	⊙	A
FLV-FR150W	White	6.1	500	⊙	⊙	B
FLV-FR150R	Red	3.5	500	⊙	⊙	B
FLV-FR150B	Blue	6.1	500	⊙	⊙	B

*1: The table shows whether each Light can be connected to Lighting Controllers. When multiple Lights are connected to a Lighting Controller, make sure that the total power consumption of all connected Lights does not exceed the power consumption of connectable Light of each Lighting Controller.

- ⊙: Connectable. Light can be continuously powered.
- : Connectable. Light can be powered only while the trigger is input.
- X: Not connectable

*2: If the Lighting requires more than 7.5 W of total power, an external power supply to the FLV-TCC is required.

Note: Refer to page 62 for LED Characteristics.

Dimensions (Unit: mm)

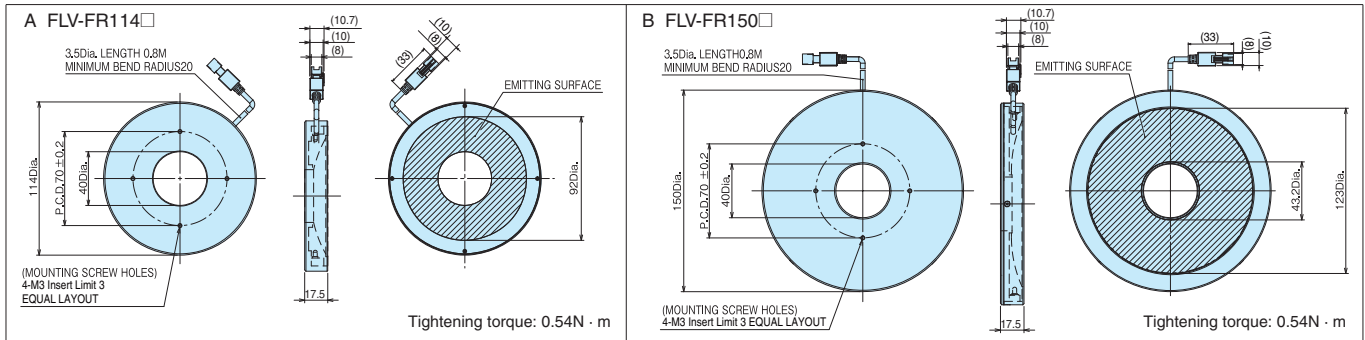

Shadowless Light FLV-FP Series

Diffused Low-angle Lighting

This series achieves highly uniform illumination across a wide field of view. Excellent symmetry eliminates diagonal shadows.

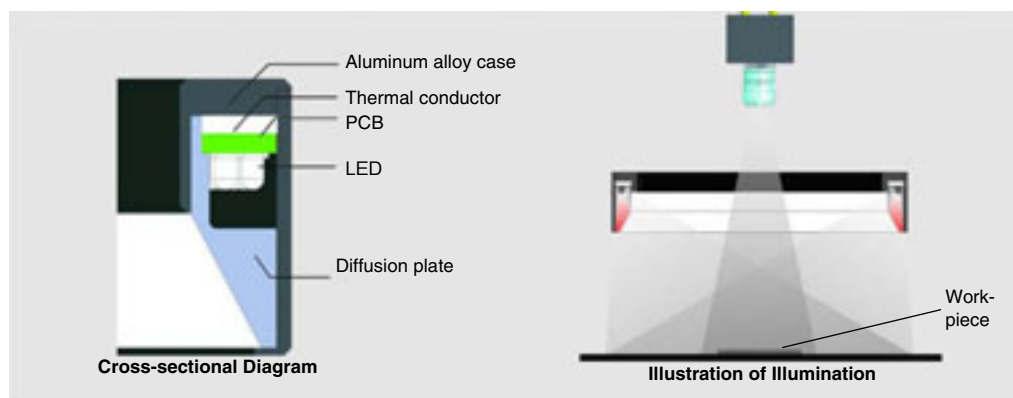

*: This figure is a conceptual illustration and may vary from the actual structure.

Product Features

- Shadowless Ring Lighting
- Achieve highly uniform illumination and obtain different images at different installation distances for a much wider range of application compared to normal ring lighting.

Applications

- Detection of bumps, scratches, and other defects on surfaces
- Recognition of printed characters
- Recognition of marks
- Recognition of barcodes



Ordering Information

Model	Light Color	Power consumption (W)	Weight (g)	Connectable Lighting Controller *1		Dimension
				Camera-mount Lighting Controller FLV-TCC Series *2	Analog Lighting Controller FLV-ATC Series	
FLV-FP130W	White	8.1	320	○	○	A
FLV-FP130R	Red	5.8	320	◎	◎	A
FLV-FP130B	Blue	8.1	320	○	◎	A

*1: The table shows whether each Light can be connected to Lighting Controllers. When multiple Lights are connected to a Lighting Controller, make sure that the total power consumption of all connected Lights does not exceed the power consumption of connectable Light of each Lighting Controller.

◎: Connectable. Light can be continuously powered. ○: Connectable. Light can be powered only while the trigger is input. X: Not connectable

*2: If the Lighting requires more than 7.5 W of total power, an external power supply to the FLV-TCC is required.

Note: Refer to page 62 for LED Characteristics.

Dimensions (Unit: mm)

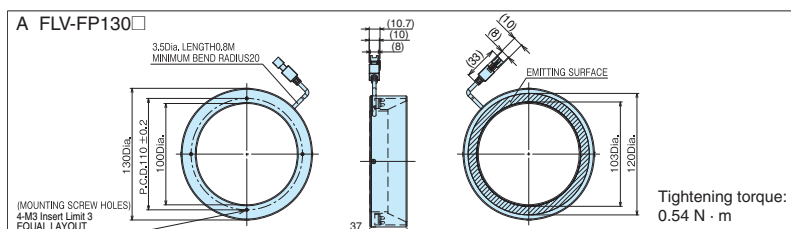

Shadowless Light FLV-FQ Series

Diffused Square Lighting

This series achieves wide highly uniform illumination across a square field of view.

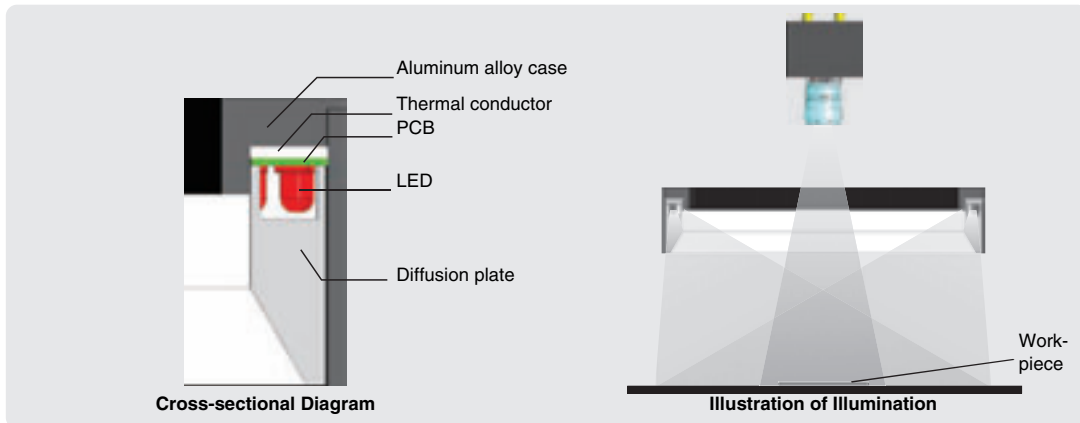

*: This figure is a conceptual illustration and may vary from the actual structure.

Product Features

- Shadowless Square Lighting
- Achieves highly uniform illumination and obtains different images at different installation distances for a much wider range of applications compared to normal ring lighting.

Applications

- Detection of defects on workpiece surfaces
- Recognition of printed characters and bar codes



Appearance Inspections of Chip Components

Ordering Information

Model	Light Color	Power consumption (W)	Weight (g)	Connectable Lighting Controller *1		Dimension
				Camera-mount Lighting Controller FLV-TCC Series *2	Analog Lighting Controller FLV-ATC Series	
FLV-FQ48W	White	2.0	100	○	○	A
FLV-FQ48R	Red	1.2	100	○	○	A
FLV-FQ48B	Blue	2.0	100	○	○	A

*1: The table shows whether each Light can be connected to Lighting Controllers. When multiple Lights are connected to a Lighting Controller, make sure that the total power consumption of all connected Lights does not exceed the power consumption of connectable Light of each Lighting Controller.

○: Connectable. Light can be continuously powered. ○: Connectable. Light can be powered only while the trigger is input. X: Not connectable

*2: If the Lighting requires more than 7.5 W of total power, an external power supply to the FLV-TCC is required.

Note: Refer to page 62 for LED Characteristics.

Dimensions (Unit: mm)

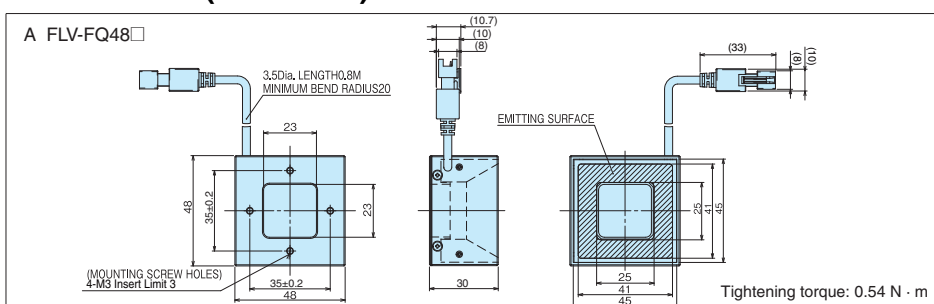

Direct Back Light FLV-DB Series

Uniform Illumination from a Flat Emitting Surface

Illumination from the back of the workpiece produces a high-contrast silhouette.

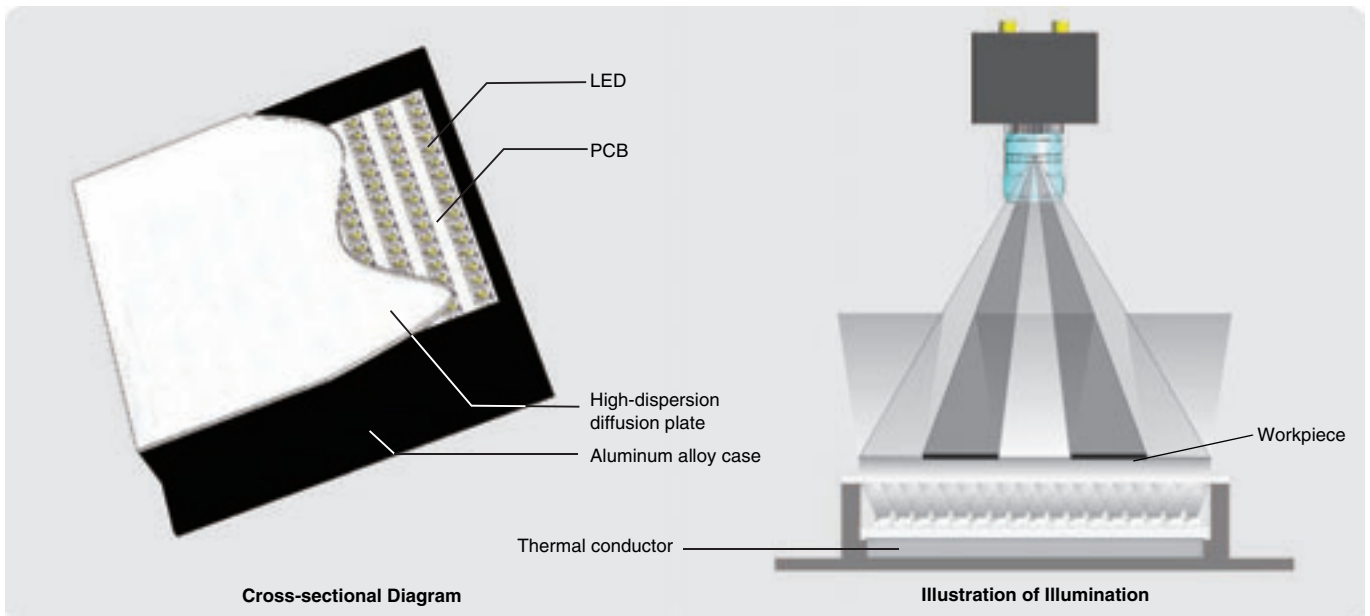
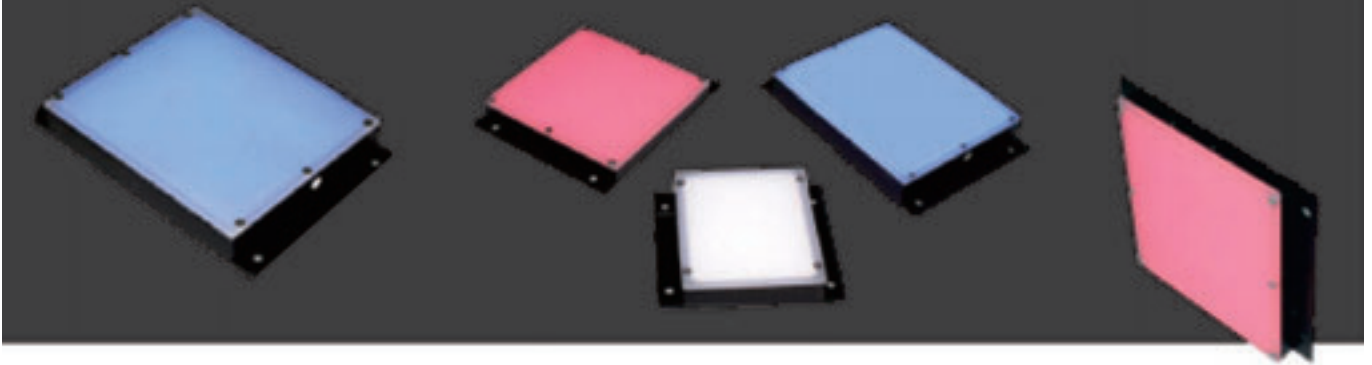

※: This figure is a conceptual illustration and may vary from the actual structure.

Product Features

- Highly uniform backlighting with high-density LED arrays. Emphasizes the outline features of workpieces.

Applications

- Size measurements of machine parts
- Shape detections for electronic components and ICs
- Dirt detection on films



Ordering Information

Model	Light Color	Power consumption (W)	Weight (g)	Connectable Lighting Controller #1		Dimension
				Camera-mount Lighting Controller FLV-TCC Series #2	Analog Lighting Controller FLV-ATC Series	
FLV-DB3729W	White	0.9	50	⊙	⊙	A
FLV-DB3729R	Red	0.9	50	⊙	⊙	A
FLV-DB3729B	Blue	0.9	50	⊙	⊙	A
FLV-DB10181W	White	8.1	160	○	⊙	B
FLV-DB10181R	Red	4.7	160	⊙	⊙	B
FLV-DB10181B	Blue	8.1	160	○	⊙	B
FLV-DB130130W	White	13.0	270	○	⊙	C
FLV-DB130130R	Red	11.5	270	○	⊙	C
FLV-DB130130B	Blue	13.0	270	○	⊙	C
FLV-DB212152W	White	29.4	510	×	⊙	D
FLV-DB212152R	Red	20.2	510	×	⊙	D
FLV-DB212152B	Blue	29.4	510	×	⊙	D

*1: The table shows whether each Light can be connected to Lighting Controllers. When multiple Lights are connected to a Lighting Controller, make sure that the total power consumption of all connected Lights does not exceed the power consumption of connectable Light of each Lighting Controller.

- ⊙: Connectable. Light can be continuously powered.
- : Connectable. Light can be powered only while the trigger is input.
- ×: Not connectable

*2: If the Lighting requires more than 7.5 W of total power, an external power supply to the FLV-TCC is required.

Note: Refer to page 62 for LED Characteristics.

Dimensions (Unit: mm)

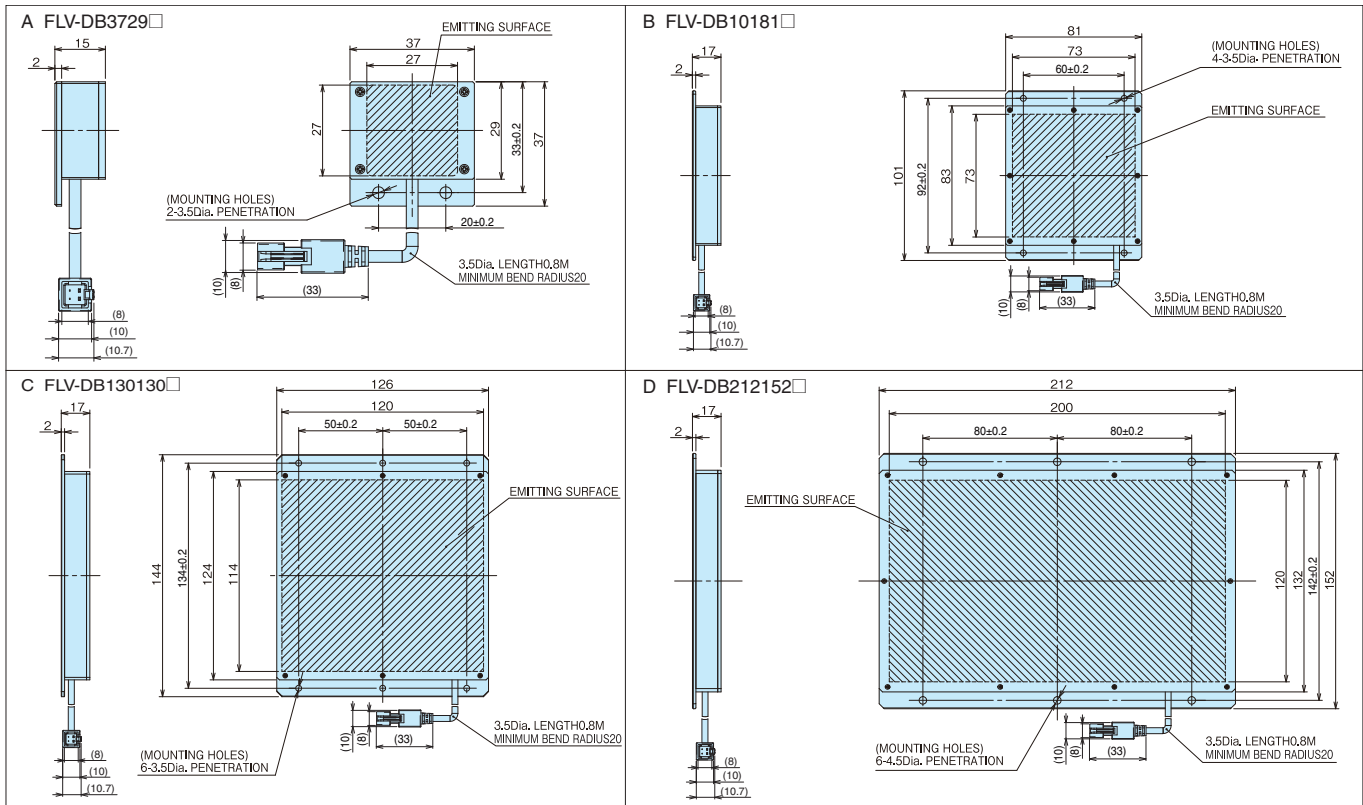

Edge Type Light FLV-FB Series

Ultrathin, Highly Uniform Backlights
Thin enough to conveniently fit into narrow spaces.

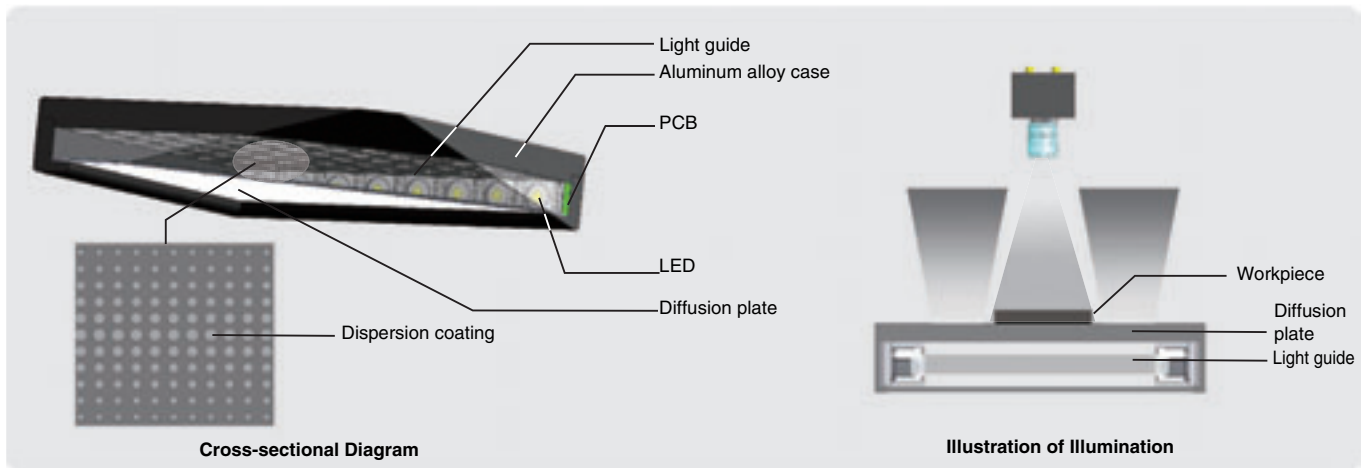
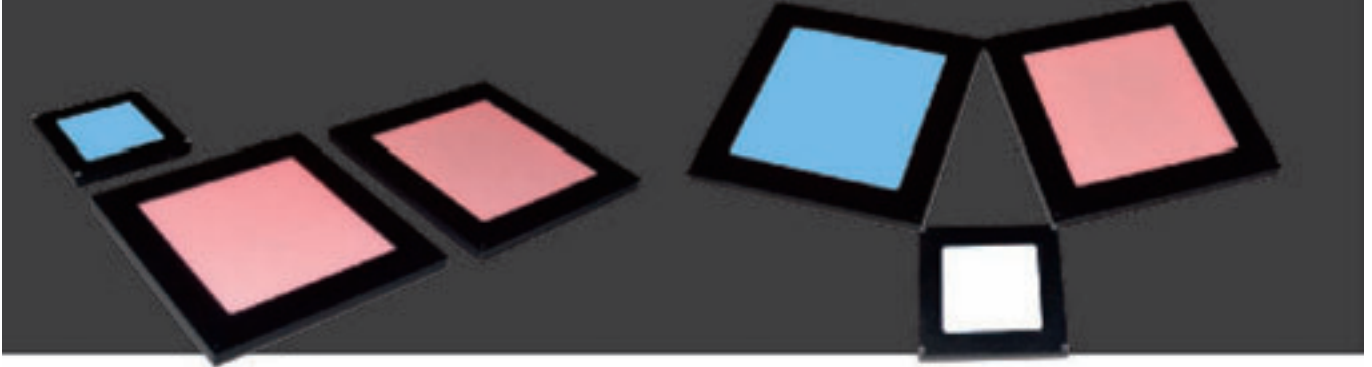

*: This figure is a conceptual illustration and may vary from the actual structure.

Product Features

- Five size variations with emitting surfaces from 35 mm square to 164 mm square.
- As thin as 8 mm (FLV-FB7070).

Applications

- Detection and size measurements of electronic devices
- Detection of LCD dead pixels

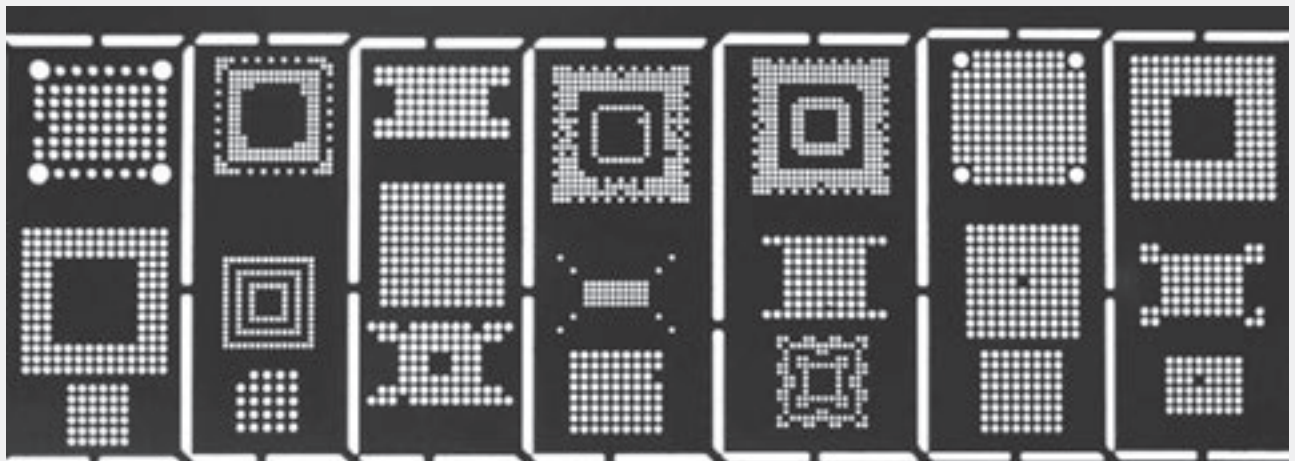

Detection of Silkscreen Patterns on Cell Phone PCBs

Ordering Information

Model	Light Color	Power consumption (W)	Weight (g)	Connectable Lighting Controller *1		Dimension
				Camera-mount Lighting Controller FLV-TCC Series *2	Analog Lighting Controller FLV-ATC Series	
FLV-FB5050W	White	1.9	75	○	○	A
FLV-FB5050R	Red	1.0	75	○	○	A
FLV-FB5050B	Blue	1.9	75	○	○	A
FLV-FB7070W	White	1.9	85	○	○	B
FLV-FB7070R	Red	1.4	85	○	○	B
FLV-FB7070B	Blue	1.9	85	○	○	B
FLV-FB9090W	White	3.7	155	○	○	C
FLV-FB9090R	Red	1.9	155	○	○	C
FLV-FB9090B	Blue	3.7	155	○	○	C
FLV-FB130130W	White	5.5	230	○	○	D
FLV-FB130130R	Red	3.7	230	○	○	D
FLV-FB130130B	Blue	5.5	230	○	○	D
FLV-FB200200W	White	7.3	710	○	○	E
FLV-FB200200R	Red	5.5	710	○	○	E
FLV-FB200200B	Blue	7.3	710	○	○	E

*1: The table shows whether each Light can be connected to Lighting Controllers. When multiple Lights are connected to a Lighting Controller, make sure that the total power consumption of all connected Lights does not exceed the power consumption of connectable Light of each Lighting Controller.

- : Connectable. Light can be continuously powered.
- : Connectable. Light can be powered only while the trigger is input.
- X: Not connectable

*2: If the Lighting requires more than 7.5 W of total power, an external power supply to the FLV-TCC is required.

Note: Refer to page 62 for LED Characteristics.

Dimensions (Unit: mm)

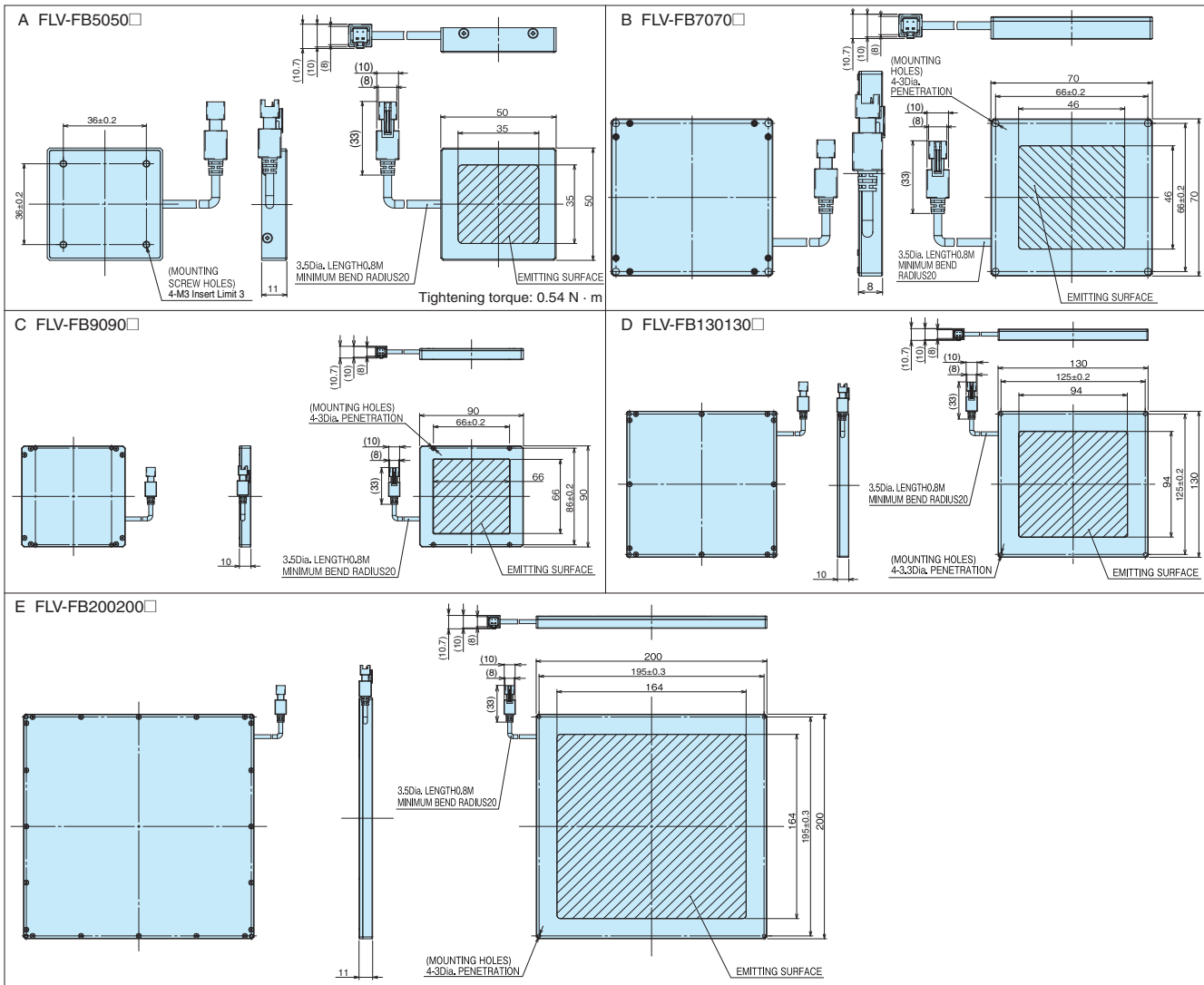

Edge Type Coaxial Light FLV-FX Series

This series features a wide range of applications with many effects, such as backlighting and coaxial lighting.

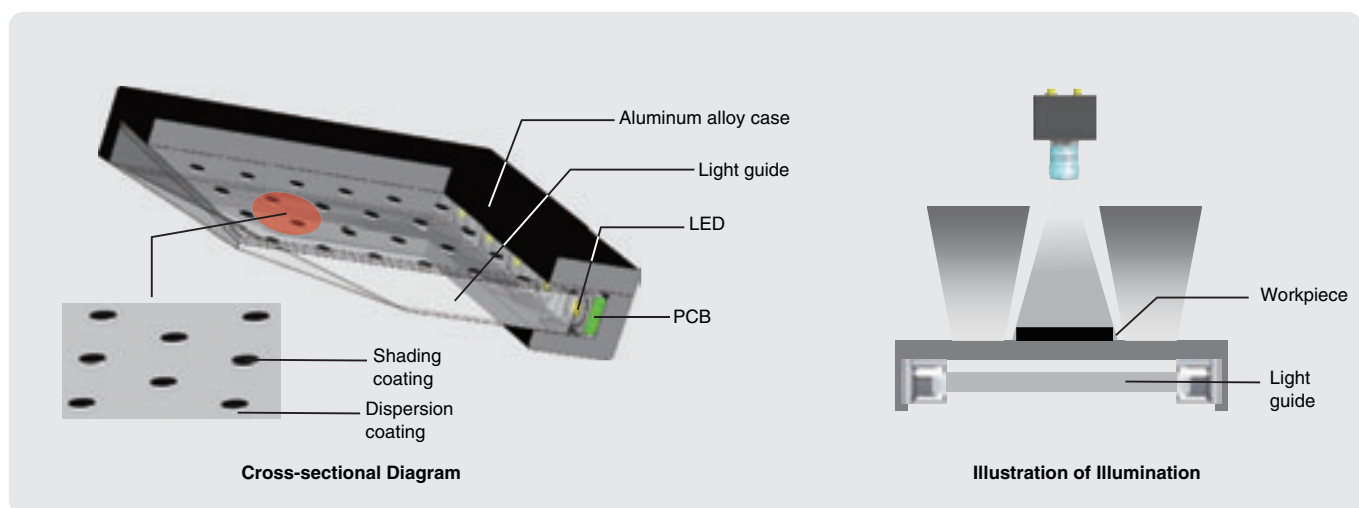

*: This figure is a conceptual illustration and may vary from the actual structure.

Product Features

- High uniformity with diffused illumination.
- Achieves both shadowless and coaxial illumination.
- Lightweight and compact to conveniently fit into narrow spaces.

Applications

- Package inspections for foodstuffs, cigarettes, and household chemicals
- Appearance inspections of home appliance cases and components
- Detection, measurement, and recognition of characters and figures on highly reflective, uneven surfaces

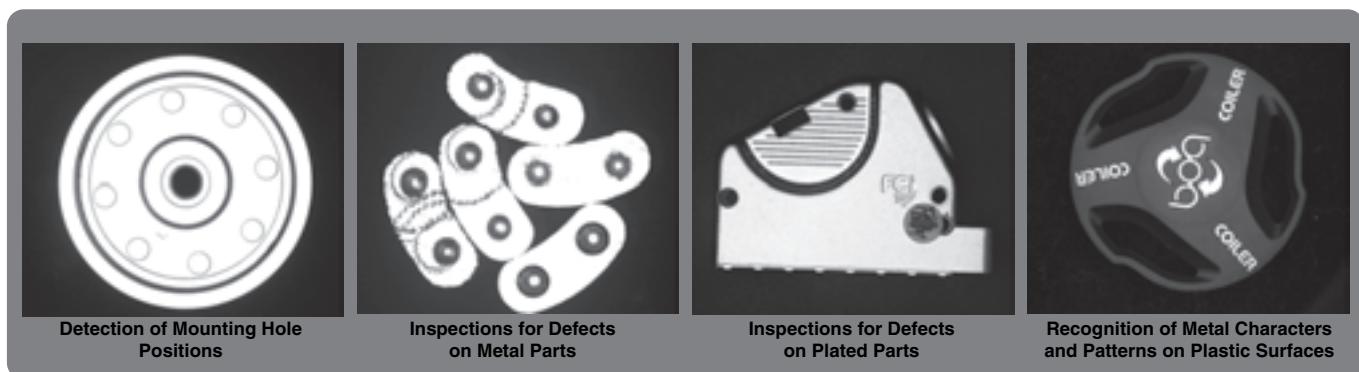

Edge Type Coaxial Light FLV-FX Series

Ordering Information

Model	Light Color	Power consumption (W)	Weight (g)	Connectable Lighting Controller *1		Dimension
				Camera-mount Lighting Controller FLV-TCC Series *2	Analog Lighting Controller FLV-ATC Series	
FLV-FX100W	White	3.7	180	⊙	⊙	A
FLV-FX100R	Red	1.9	180	⊙	⊙	A
FLV-FX100B	Blue	3.7	180	⊙	⊙	A
FLV-FX143W	White	5.5	240	⊙	⊙	B
FLV-FX143R	Red	3.7	240	⊙	⊙	B
FLV-FX143B	Blue	5.5	240	⊙	⊙	B

*1: The table shows whether each Light can be connected to Lighting Controllers. When multiple Lights are connected to a Lighting Controller, make sure that the total power consumption of all connected Lights does not exceed the power consumption of connectable Light of each Lighting Controller.

- ⊙: Connectable. Light can be continuously powered.
- : Connectable. Light can be powered only while the trigger is input.
- X: Not connectable

*2: If the Lighting requires more than 7.5 W of total power, an external power supply to the FLV-TCC is required.

Note: Refer to page 62 for LED Characteristics.

Dimensions (Unit: mm)

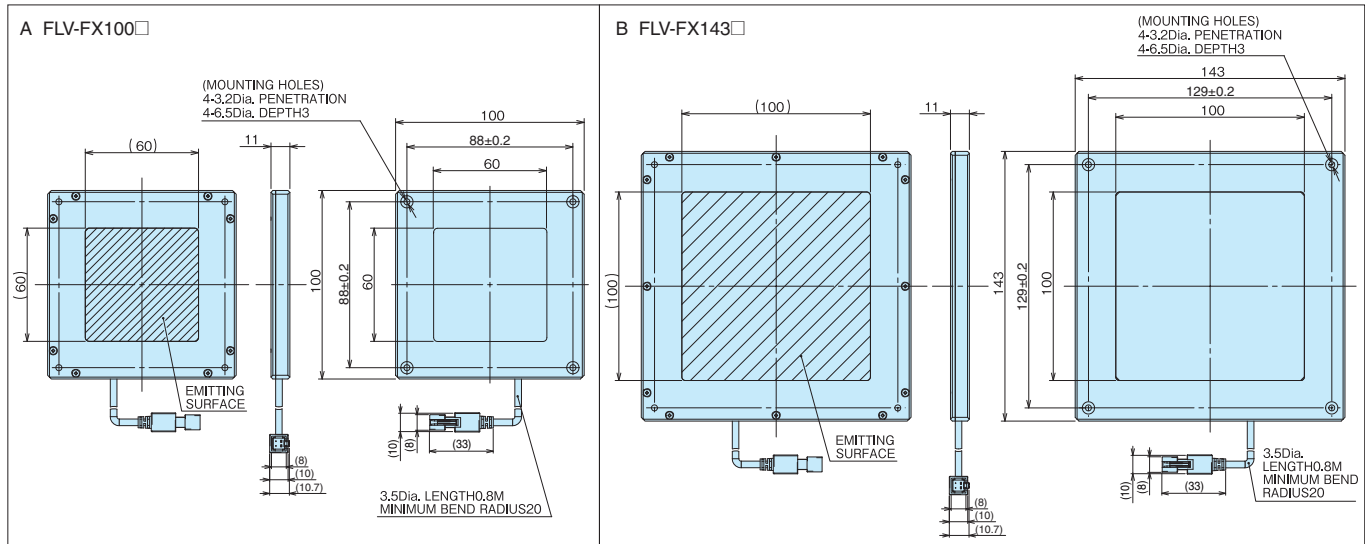

Dome Light FLV-DD Series

Uniform Illumination from All Directions

This series produces shadowless images of the entire workpiece.

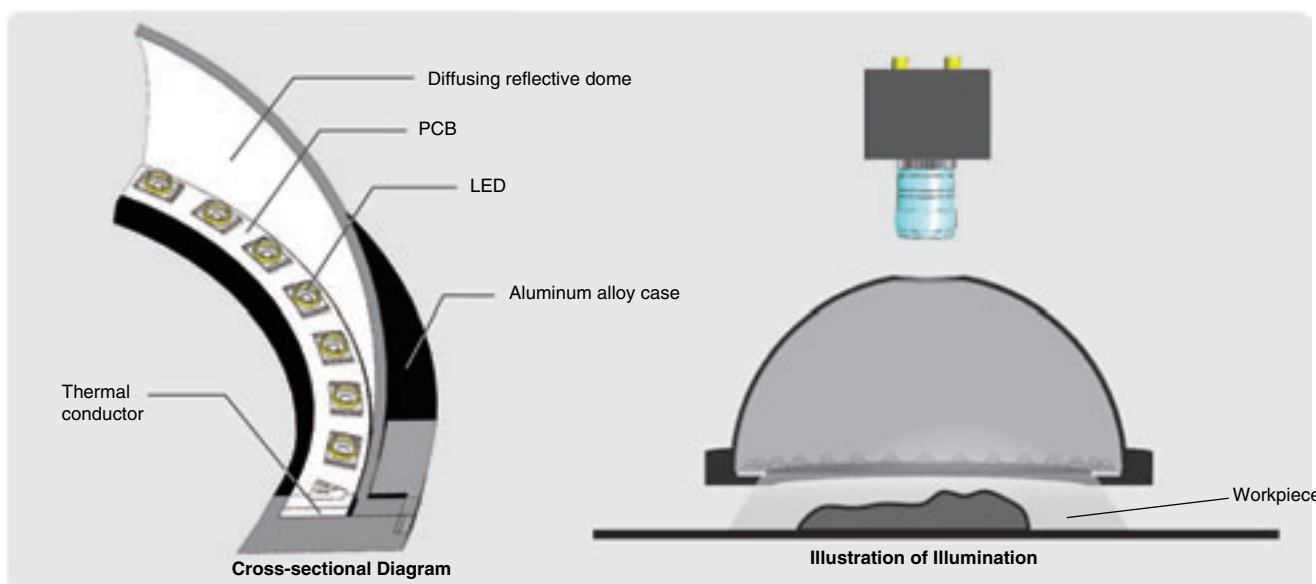

*: This figure is a conceptual illustration and may vary from the actual structure.

Product Features

- Achieves uniform illumination by reflecting light from a ring-shaped light source through a highly reflective, diffusion dome.

Applications

- Detection of characters and marks on curved or uneven surfaces
- Detection of highly reflective surfaces, such as metal or glass
- Shape measurements of curved or uneven workpieces



Inspection of Date Characters on Drink Cans



Detection of Characters on Cell Phones

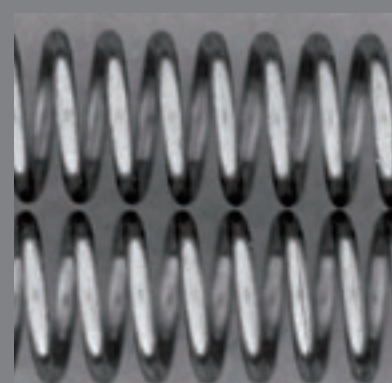

Detection of Cracks on Spring Surfaces

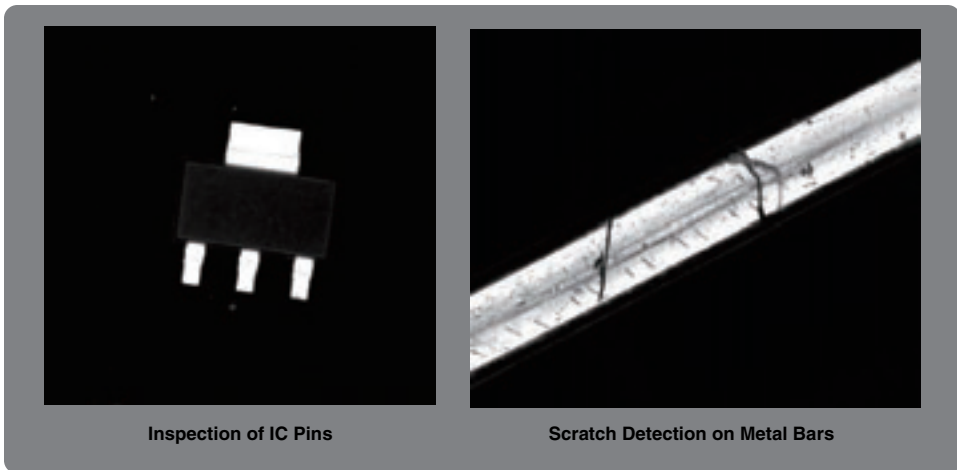

Inspection of IC Pins

Scratch Detection on Metal Bars

Ordering Information

Model	Light Color	Power consumption (W)	Weight (g)	Connectable Lighting Controller *1		Dimension
				Camera-mount Lighting Controller FLV-TCC Series *2	Analog Lighting Controller FLV-ATC Series	
FLV-DD70W	White	2.3	130	⊙	⊙	A
FLV-DD70R	Red	1.4	130	⊙	⊙	A
FLV-DD70B	Blue	2.3	130	⊙	⊙	A
FLV-DD100W	White	17.9	210	×	⊙	B
FLV-DD100R	Red	11.9	210	○	⊙	B
FLV-DD100B	Blue	17.9	210	×	⊙	B
FLV-DD150W	White	17.9	490	×	⊙	C
FLV-DD150R	Red	11.9	490	○	⊙	C
FLV-DD150B	Blue	17.9	490	×	⊙	C

*1: The table shows whether each Light can be connected to Lighting Controllers. When multiple Lights are connected to a Lighting Controller, make sure that the total power consumption of all connected Lights does not exceed the power consumption of connectable Light of each Lighting Controller.

⊙: Connectable. Light can be continuously powered. ○: Connectable. Light can be powered only while the trigger is input. X: Not connectable

*2: If the Lighting requires more than 7.5 W of total power, an external power supply to the FLV-TCC is required.

Note: Refer to page 62 for LED Characteristics.

Dimensions (Unit: mm)

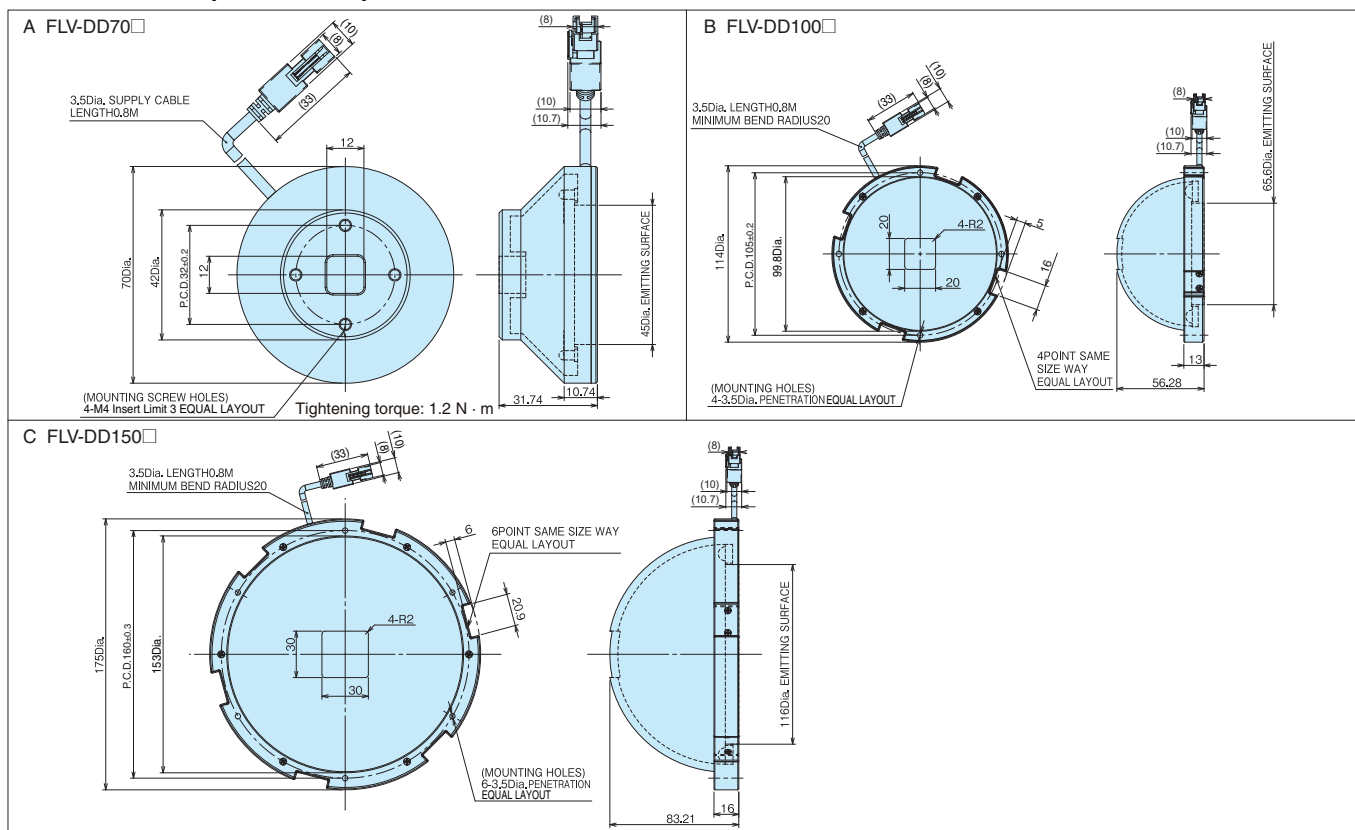

High-power Spot Light FLV-EP08 Series

High-power, Compact Spot Light Sources

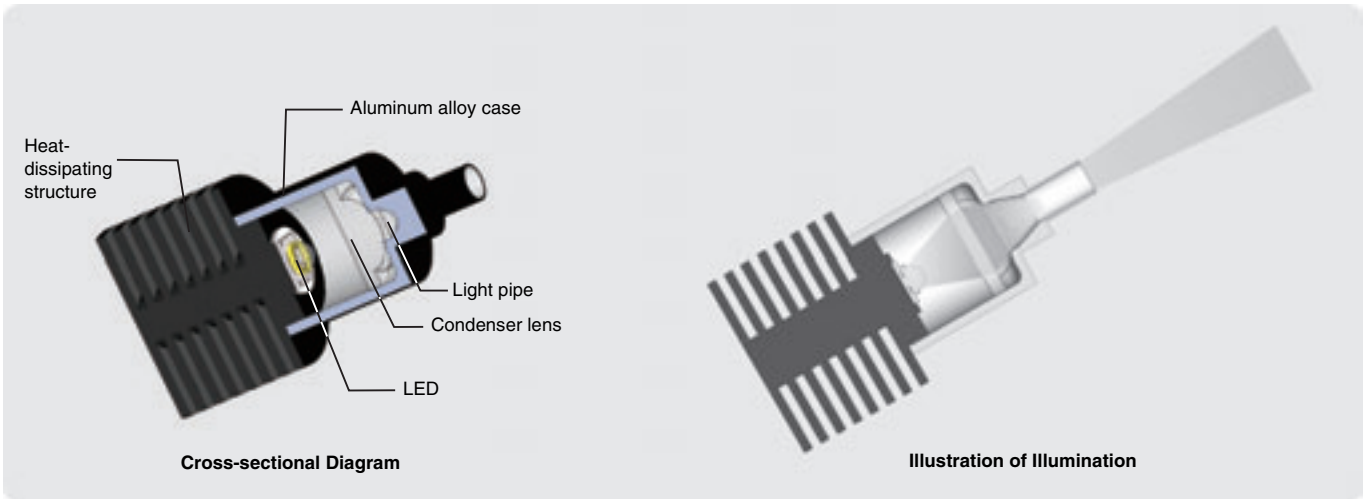

*:This figure is a conceptual illustration and may vary from the actual structure.

Product Features

- High-power LEDs generate strong light with a compact design.
- Ideal for applications in combination with a Coaxial Lens.
- Highly efficient heat-dissipating structure ensures a long life.

Applications

- Detection of alignment marks
- Detection of chips
- Detection of defects on workpiece surfaces

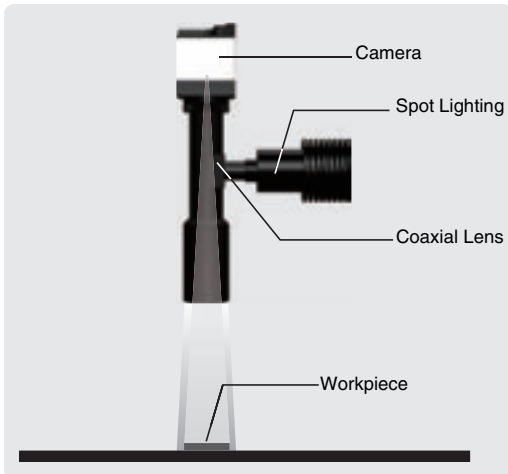
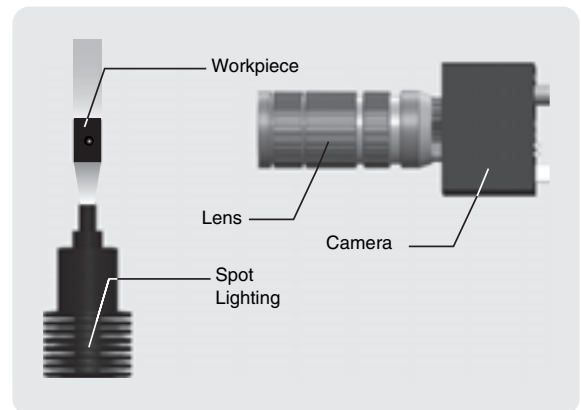
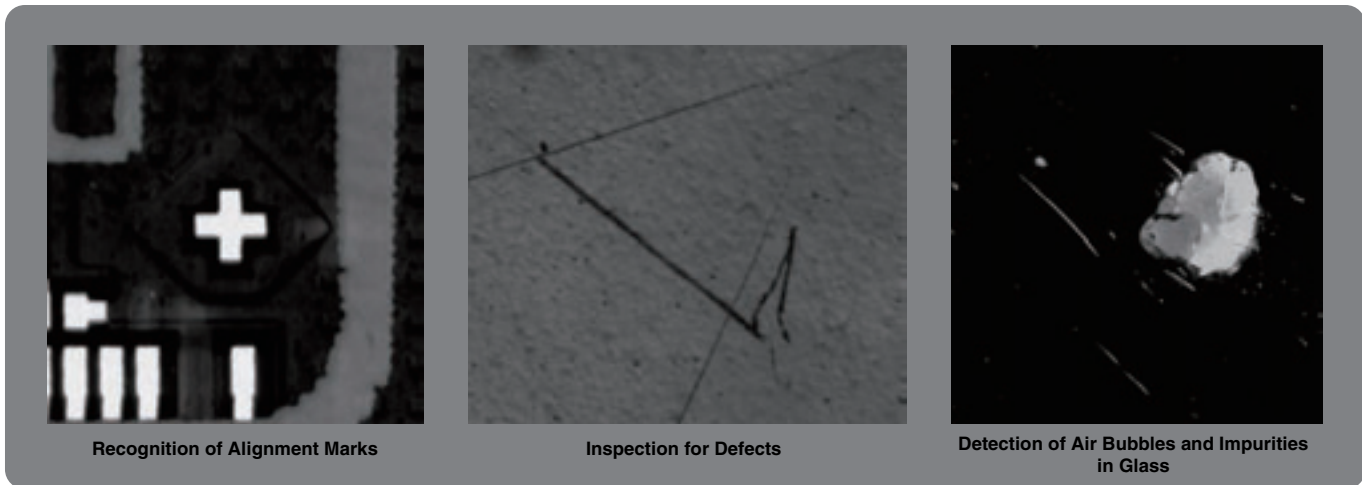

Illustration of Illumination in Combination with a Coaxial Lens



Simplified Illustration of Detection of Bubbles in Transparent Material



Ordering Information

Model	Light Color	Power consumption (W)	Weight (g)	Connectable Lighting Controller *1		Dimension
				Camera-mount Lighting Controller FLV-TCC Series *2	Analog Lighting Controller FLV-ATC Series	
FLV-EP0803W	White	1.6	80	×	⊙	A
FLV-EP0803R	Red	1.1	80	×	⊙	A
FLV-EP0803B	Blue	1.6	80	×	⊙	A

*1: The table shows whether each Light can be connected to Lighting Controllers. When multiple Lights are connected to a Lighting Controller, make sure that the total power consumption of all connected Lights does not exceed the power consumption of connectable Light of each Lighting Controller.

- ⊙: Connectable. Light can be continuously powered.
- : Connectable. Light can be powered only while the trigger is input.
- ×: Not connectable

*2: An Analog Lighting Controller for Spot Lighting (FLV-ATC10405/-ATC40405) is required.

Note: Refer to page 62 for LED Characteristics.

Dimensions (Unit: mm)

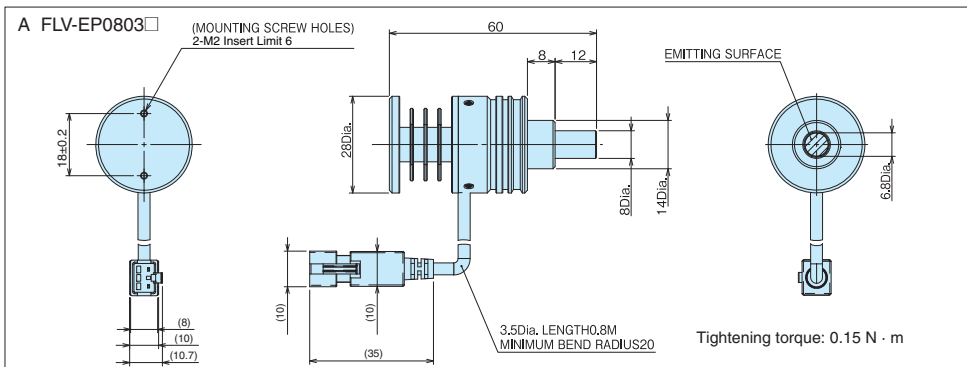

Spot Light FLV-EP50 Series

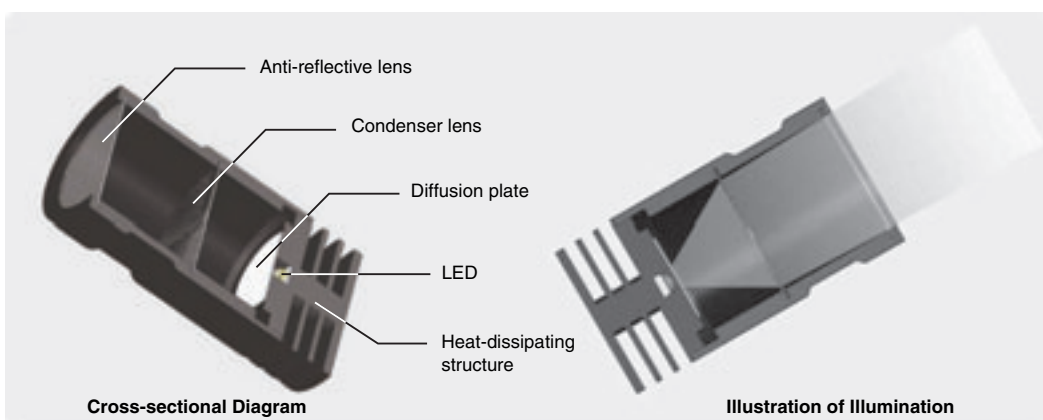

*: This figure is a conceptual illustration and may vary from the actual structure.

Product Features

- Superior directional characteristic, essentially parallel light, and long-distance illumination.

Applications

- Size measurements of small workpieces
- Detection of defects on surfaces

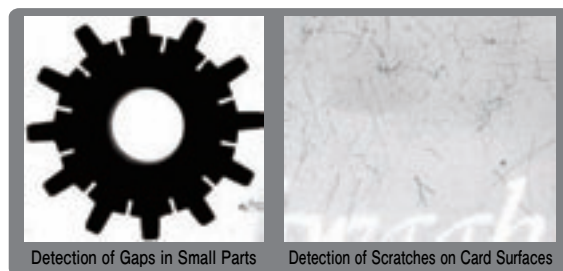

Ordering Information

Model	Light Color	Power consumption (W)	Weight (g)	Connectable Lighting Controller *1		Dimension
				Camera-mount Lighting Controller FLV-TCC Series *2	Analog Lighting Controller FLV-ATC Series	
FLV-EP50W	White	1.6	200	X	⊙	A
FLV-EP50R	Red	1.1	200	X	⊙	A

*1: The table shows whether each Light can be connected to Lighting Controllers. When multiple Lights are connected to a Lighting Controller, make sure that the total power consumption of all connected Lights does not exceed the power consumption of connectable Light of each Lighting Controller.

⊙: Connectable. Light can be continuously powered. ○: Connectable. Light can be powered only while the trigger is input. X: Not connectable

*2: An Analog Lighting Controller for Spot Lighting (FLV-ATC10405/-ATC40405) is required.
Note: Refer to page 62 for LED Characteristics.

Dimensions (Unit: mm)

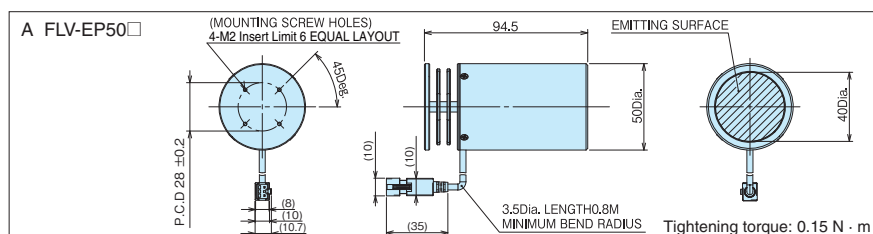

Line Light FLV-LN Series

Exceptionally Bright, Highly Uniform Line Lighting
This series is ideal for high-speed processing with line cameras.

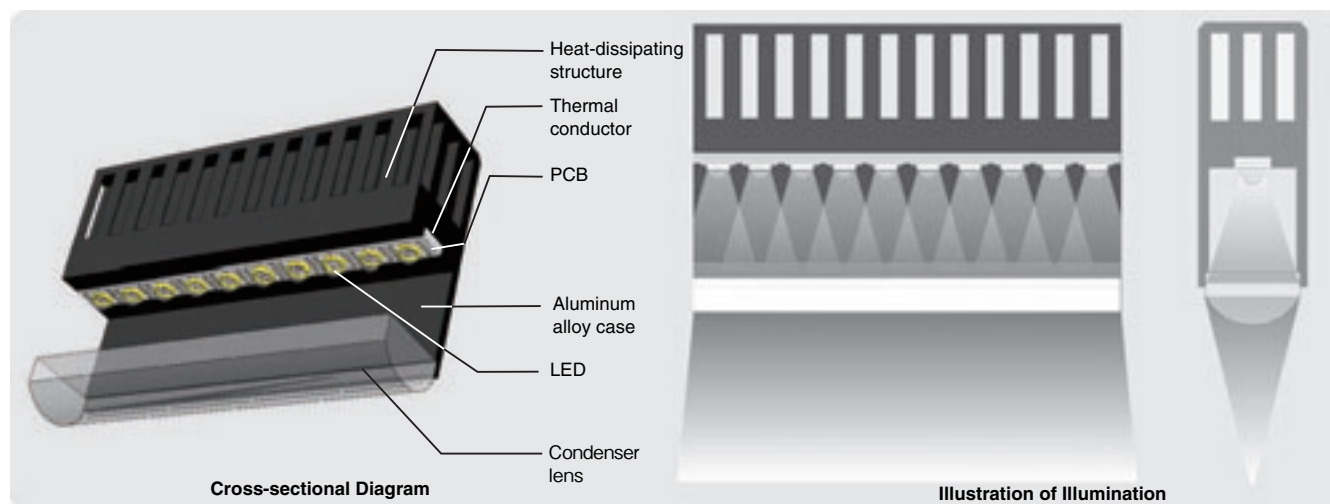

*: This figure is a conceptual illustration and may vary from the actual structure.

Product Features

- Extremely high brightness
- Achieves highly effective line illumination with a condenser lens.

Applications

- Printing inspections
- Sheet inspections
- Detection of film and glass surface damage and internal impurities

Ordering Information

Model	Light Color	Power consumption (W)	Weight (g)	Connectable Lighting Controller *1		Dimension
				Camera-mount Lighting Controller FLV-TCC Series *2	Analog Lighting Controller FLV-ATC Series	
FLV-LN82W	White	9.2	640	×	○	A
FLV-LN82B	Blue	9.2	640	×	○	A
FLV-LN122R	Red	10.4	800	×	○	E
FLV-LN142W	White	18.4	890	×	○	B
FLV-LN142B	Blue	18.4	890	×	○	B
FLV-LN222R	Red	20.7	1320	×	○	F
FLV-LN322W	White	45.9	1950	×	○	C
FLV-LN322B	Blue	45.9	1950	×	○	C
FLV-LN322R	Red	31.1	1950	×	○	G
FLV-LN442W	White	64.3	2450	×	○	D
FLV-LN442B	Red	64.3	2450	×	○	D
FLV-LN422R	Red	41.4	2400	×	○	H

*1: The table shows whether each Light can be connected to Lighting Controllers. When multiple Lights are connected to a Lighting Controller, make sure that the total power consumption of all connected Lights does not exceed the power consumption of connectable Light of each Lighting Controller.

○: Connectable. Light can be continuously powered. ○: Connectable. Light can be powered only while the trigger is input. X: Not connectable

*2: An Analog Lighting Controller for Line Lighting (FLV-ATC26024-100V/-200V) is required.

Note: Refer to page 62 for LED Characteristics.

Camera-mount Lighting Controller for FLV Series

FLV-TCC Series

Compact Lighting Controller
Mounts directly to OMRON Cameras
Multistage Control of Lighting on
Up to Four Lights can be connected.



Product Features

- Saves space with a compact design.
No need for space in control panels for expansion.
- Maintain Lighting intensity even with long wiring distances.
- No complicated wiring from the Vision System Controller.

<Standard Lighting System>

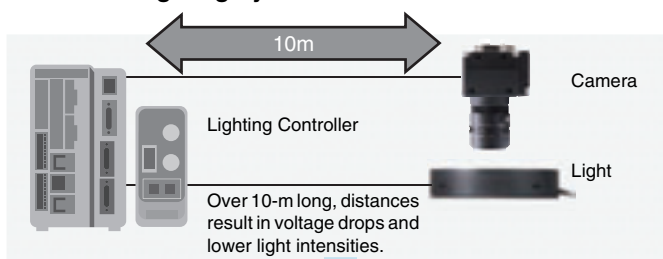

<FLV-TCC Series>

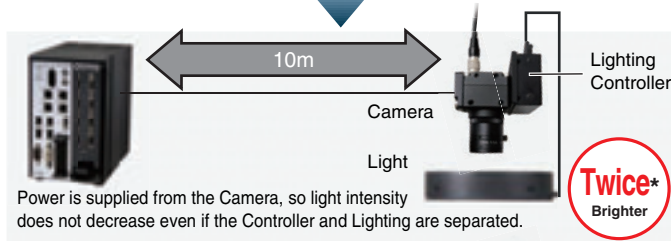

* When the extension cable length is 10 m.

Ordering Information

Model	Number of Channels	Applicable Lighting*5			Power Supply Voltage	Maximum Lighting power	Luminance Control Method
		Standard Light FLV Series *1	Spot Light FLV-EP Series	Line Light FLV-LN Series			
FLV-TCC1	1	○	×	×	24 VDC *2	15 W max. *3	Digital *4
FLV-TCC4	4	○	×	×			

*1. Standard light means all FLV-series Lights excluding the FLV-EP-series Spot Lights and the FLV-LN-series Line Lights.

*2. If the total power consumption of Lights is 7.5 W or less, an external power supply is not required because the power is supplied from the Camera.

*3. For triggered lighting, 50% duty.

*4. Intensity can be controlled by setting from the Vision System Controller.

*5. ○: Connectable.

×: Not connectable

Camera-mount Lighting Controller for FLV Series FLV-TCC Series

Specifications

Item	Model	FLV-TCC1	FLV-TCC4
Number of connectable lightings		1	4
Applicable light		FLV series (FLV-EP series and FLV-LN series are excluded.)	
Applicable camera		FH-S series, FZ-S series	
Applicable vision system controller		FH series, FZ5 series	
Input voltage		Supplied from applicable camera (13 V) or external power supply (24 V)	
External power supply voltage *1		24 VDC±10% (including ripple)	
Current consumption		1.5 A max.	
	Recommended power supply	S8VS-06024 (manufactured by OMRON, 24 VDC, 2.5 A, 60 W)	
Power for connectable lighting			
13 VDC supplied through camera			
	Continuous lighting	7.5 W max.	4ch total 7.5 W max.
	Trigger lighting	Simultaneous lighting	4ch total 7.5 W max.
			Individual lighting
24 VDC external power supply			
	Continuous lighting	7.5 W max.	4ch total 7.5 W max.
	Trigger lighting	Simultaneous lighting	4ch total 15 W max. (duty: 50% max.)
			Individual lighting
Drive method		Contrast voltage method	
Lighting method		Trigger lighting, Continuous lighting	
Intensity control method		Duty light adjustment or voltage light adjustment Duty light adjustment: PWM frequency of 100 kHz, light adjustment of 255 levels Voltage light adjustment: Light adjustment of 255 levels (all are set with vision sensor controller)	
Trigger lighting		Lighting in synchronization with trigger input timing from the controller. (auto setting in accordance with shutter speed)	
	Trigger lighting delay time	T _{on} : 30 μs max.	
External interface		Camera connection cable (directly connected with the main unit)	
Insulation resistance		0.5 MΩ (100 VDC)	
Ambient temperature		Operating: 0 to 50°C, Storage: -15 to 60°C (with no icing or condensation)	
Ambient humidity		Operating/storage: 35% to 85% (with no condensation)	
Degree of protection		IP20 (IEC60529)	
Vibration resistance (destructive)		10 to 150 Hz, (0.7 mm double amplitude) 80 min each in X, Y, and Z directions	
Shock resistance (destructive)		150 m/s ² 3 times each in 6 directions (up/down, left/right, forward/backward)	
Materials		Case: Aluminum, Cable: PVC, Camera mount plate: Aluminum	
Weight		Approx. 120 g (including the camera mount plate)	Approx. 130 g (including the camera mount plate)
Accessories		Instruction sheet, Camera mount plate, Mounting screws (M2 set screw × 4, M2 flat head screw × 4, M4 flat head screw × 4)	
Applicable standards		EN: EN61326, EMC: No.2004/108/EC	

*1. When power is supplied from an external input power supply (24 V), turn ON power to the Lighting Controller at the same time as or before supplying power to the Vision System Controller.

If power is supplied to the Vision System Controller first, the Lighting Controller will not recognize the 24-V external power supply input, so Lightings which require more than 7.5 W of power will not turn ON.

Analog Lighting Controller for FLV Series FLV-ATC Series

Stationary Lighting Controller



Product Features

- Stationary type suitable for separate installation when no space near the Camera.
- Light emission trigger can be input directly even without Vision Sensor.

Ordering Information

Applicable Light	Model	Number of Channels	Power Supply Voltage	Maximun Lighting power	Luminance Control Method
For Standard Light *1	FLV-ATC21024 *2	2	100 to 240 VAC, 50/60 Hz	40 W max.	Analog
	FLV-ATC41024 *2	4		3 W max.	
For Spot Light	FLV-ATC10405 *2	1		12 W max.	
	FLV-ATC40405 *2	4			
For Line Light	FLV-ATC26024-100V *2	2	100 to 120 VAC, 50/60 Hz	240 W max.	
	FLV-ATC26024-200V	2	200 to 240 VAC, 50/60 Hz		

*1. Standard Light means all FLV-series Lights excluding the FLV-EP-series Spot Lights and the FLV-LN-series Line Lights.

*2. For AC power cords: An A-type plug is standard. C-type and O-type plugs are also available. (Add “-C” or “-O” to the end of the model number.)

Plug type	A	C	O
Rated voltage	125 V	240 V	240 V
Standard	PSE	CEE	CCC

AC Power Cords with A-type Plugs

⚠ WARNING

The cable included in this package can be applied only to AC 100V commercial power in Japan. You can not use it in the country outside Japan.

Please never use it on the voltage beyond AC100V.

It becomes a cause of ignition, generation of heat, and failure.



Please prepare the cable appropriate to the specification of the commercial power in your country, when you use it on the voltage beyond AC 100V, for example, in the country outside Japan.

●Lighting Controller for Standard Light FLV-ATC21024/-ATC41024

Part Names and Functions

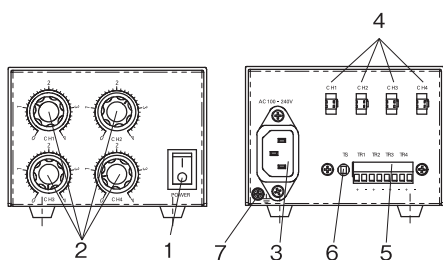

No.	Name	Description
1	Main power supply	Starts up the Controller when it is turned ON.
2	Lighting adjustment volume	Rotating the volume clockwise increases the emission intensity or counterclockwise decreases it.
3	AC power supply input connector	A terminal to supply AC power. Connect the provided AC input cable.
4	Lighting connector	Connects an LED lights.
5	Trigger input terminal block	A terminal block for lighting illumination trigger input from outside to each lighting.
6	Lighting mode switching button	Lighting mode switch button is ON (The button is pushed.): Short-circuiting (+) and (-) of TR1 to TR4 respectively makes the trigger input status ON, turning the light ON. Releasing (+) and (-) makes the status OFF, turning the light OFF. Lighting mode switch button is OFF (The button is not pushed.): Short-circuit (+) and (-) of TR1 to TR4 respectively makes the trigger input status OFF, turning the light OFF. Releasing (+) and (-) makes the status ON, turning the light ON.
7	Frame ground terminal	A terminal for frame ground. Connect the ground line.

Analog Lighting Controller for FLV Series FLV-ATC Series

Specifications

Item	Model	FLV-ATC21024-□ *1	FLV-ATC41024-□ *1
Number of connectable lightings		1	4
Applicable light		FLV series (FLV-EP series and FLV-LN series are excluded.)	
Power supply voltage *2		100 to 240 VAC, 50/60 Hz	
Current consumption		1 A max.	
Electricity of connectable lighting		2ch total 40 W max. 30 W max. for 1ch	4ch total 40 W max. 30 W max. for 1ch
Drive method		Constant voltage method	
Lighting method		Trigger lighting, Continuous lighting	
Intensity control method		Voltage light adjustment: 14.0 to 24.0 V	
Trigger lighting		Lighting in synchronization with input from the trigger input terminal	
Trigger lighting delay time		T_on: 100 μs max.	
External interface		Trigger input terminal block	
Dielectric strength		1500 VAC	50/60 Hz 1 min
Insulation resistance		20 MΩ (500 VDC)	
Ambient temperature		Operating: 0 to 50°C, Storage: -15 to 60°C (with no icing or condensation)	
Ambient humidity		Operating/storage: 35% to 85% (with no condensation)	
Degree of protection		IP20 (IEC60529)	
Vibration resistance (destructive)		10 to 150 Hz, (0.2 mm double amplitude) 80 min each in X, Y, and Z directions	
Shock resistance (destructive)		150 m/s ² 3 times each in 6 directions (up/down, left/right, forward/backward)	
Materials		Case: Aluminum	
Weight		Approx. 800 g	
Accessories		Instruction sheet, AC input cable *1	
Applicable standards		EN: EN61326, EMC: No.2004/108/EC	

*1: The suffixed symbol of the model name means the plug type of the accessory cable. A model name with no suffix means type A.

*2: This product is the exclusive use for apparatus inclusion in the industrial machine field.

This product cannot be used for the connection to electric power equipment, such as a common residence, store, and small establishment, because of nonconformity with to Electrical Appliance and Material Safety Law (PSE).

Connecting to External Trigger Input Terminal Block

- Connection of this terminal block is not required if lighting illumination trigger input from outside is not used.

<Connection of trigger input terminal block>

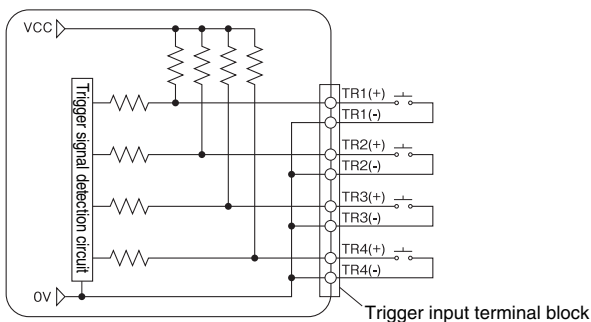

* Current flowing through the short circuit is less than 2 mA.

● FLV-ATC21024-□

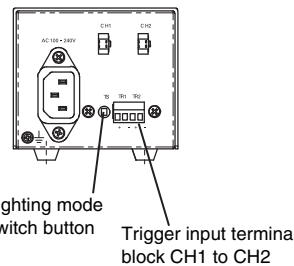

Lighting mode switch button
Trigger input terminal block CH1 to CH2

● FLV-ATC41024-□

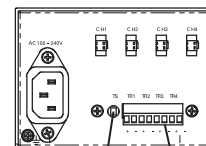

Lighting mode switch button
Trigger input terminal block CH1 to CH4

Lighting mode switch button is ON (The button is pushed.)

Short-circuiting (+) and (-) of TR1 to TR4 respectively makes the trigger input status ON, turning the light ON.
Releasing (+) and (-) makes the status OFF, turning the light OFF.

Lighting mode switch button is OFF (The button is not pushed.)

Short-circuit (+) and (-) of TR1 to TR4 respectively makes the trigger input status OFF, turning the light OFF.
Releasing (+) and (-) makes the status ON, turning the light ON.

[Important]

- Make sure that excessive force is not imposed on the wire and terminal block.
- Do not install the product in which loads are constantly applied to the terminal block such as the wire being under tension.
- When wiring the terminal block, use an applicable cable (AWG 14 to 24, tip processing length: 7 mm).

Analog Lighting Controller for FLV Series FLV-ATC Series

Dimensions (Unit: mm)

●FLV-ATC21024-□

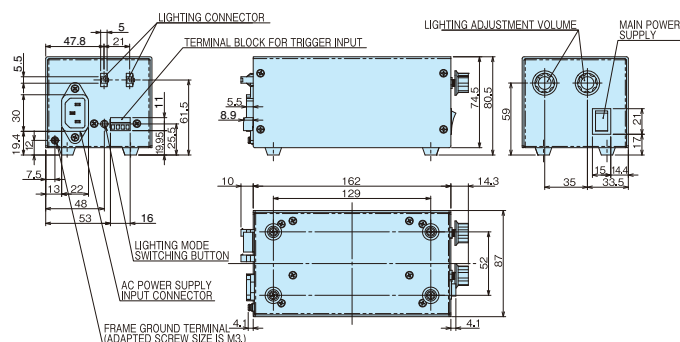

●FLV-ATC41024-□

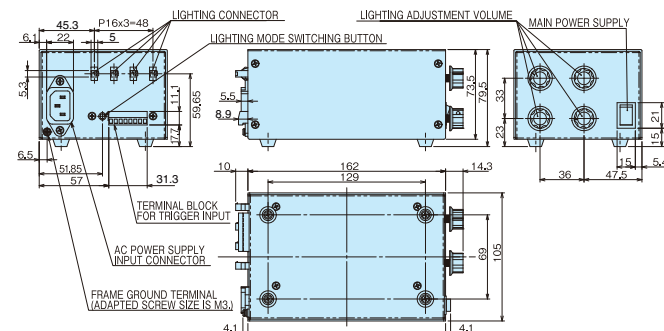

●Lighting Controller for Spot Light FLV-ATC10405/-ATC40405

Part Names and Functions

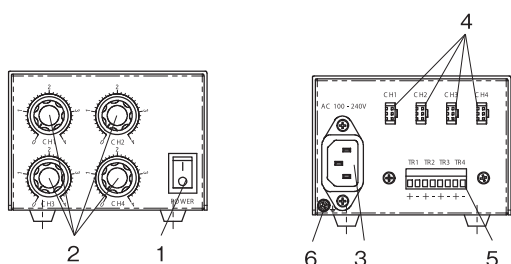

No.	Name	Description
1	Main power supply	Starts up the Controller when it is turned ON.
2	Lighting adjustment volume	Rotating the volume clockwise increases the emission intensity or counterclockwise decreases it.
3	AC power supply input connector	A terminal to supply AC power. Connect the provided AC input cable.
4	Lighting connector	Connects an LED lights.
5	Terminal block for trigger input	A terminal block for lighting illumination trigger input from outside to each lighting.
6	Frame ground terminal	A terminal for frame ground. Connect the ground line.

Specifications

Item	Model	FLV-ATC10405-□ *1	FLV-ATC40405-□ *1
Number of connectable lightings		1	4
Applicable light		FLV-EP series	
Power supply voltage *2		100 to 240 VAC, 50/60 Hz	
Current consumption		0.6 A max.	
Electricity of connectable lighting		3 W max.	4ch total 12 W max. 3 W max. for 1ch
Drive method		Constant current method	
Lighting method		Trigger lighting, Continuous lighting	
Luminance control method		Current light adjustment : 0.4 A max.	
Trigger lighting		Turning the light off in synchronization with input from the trigger input terminal	
Trigger lighting delay time		T_on: 1000 μs max.	
External interface		Trigger input terminal block	
Dielectric strength		1500 VAC 50/60 Hz 1 min	
Insulation resistance		20 MΩ (500 VDC)	
Ambient temperature		Operating: 0 to 50°C, Storage: -15 to 60°C (with no icing or condensation)	
Ambient humidity		Operating/storage: 35% to 85% (with no condensation)	
Degree of protection		IP20 (IEC60529)	
Vibration resistance (destructive)		10 to 150 Hz, (0.2 mm double amplitude) 80 min each in X, Y, and Z directions	
Shock resistance (destructive)		150 m/s ² 3 times each in 6 directions (up/down, left/right, forward/backward)	
Materials		Case: Aluminum	
Weight		Approx. 800 g	
Accessories		Instruction sheet, AC input cable *1	
Applicable standards		EN: EN61326, EMC: No.2004/108/EC	

*1: The suffixed symbol of the model name means the plug type of the accessory cable. A model name with no suffix means type A.

*2: This product is the exclusive use for apparatus inclusion in the industrial machine field.

This product cannot be used for the connection to electric power equipment, such as a common residence, store, and small establishment, because of nonconformity with to Electrical Appliance and Material Safety Law (PSE).

Analog Lighting Controller for FLV Series FLV-ATC Series

Connecting to External Trigger Input Terminal Block

- Connection of this terminal block is not required if lighting illumination trigger input from outside is not used.

<Connection of trigger input terminal block>

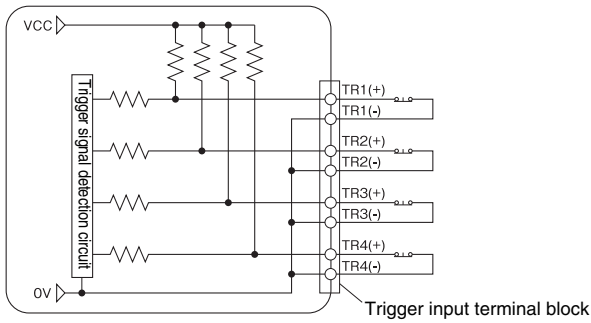

* Current flowing through the short circuit is less than 1 mA.

● FLV-ATC10405-□

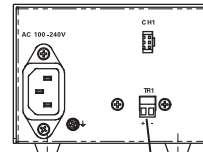

Trigger input terminal block CH1

● FLV-ATC40405-□

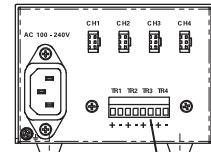

Trigger input terminal block CH1 to CH4

Short-circuiting (+) and (-) of TR1 to TR4 respectively makes the trigger input status OFF, turning the light OFF.
Releasing (+) and (-) makes the status ON, turning the light ON.

[Important]

- Make sure that excessive force is not imposed on the wire and terminal block.
- Do not install the product in which loads are constantly applied to the terminal block such as the wire being under tension.
- When wiring the terminal block, use an applicable cable (AWG 14 to 24, tip processing length: 7 mm).

Dimensions (Unit: mm)

● FLV-ATC10405-□

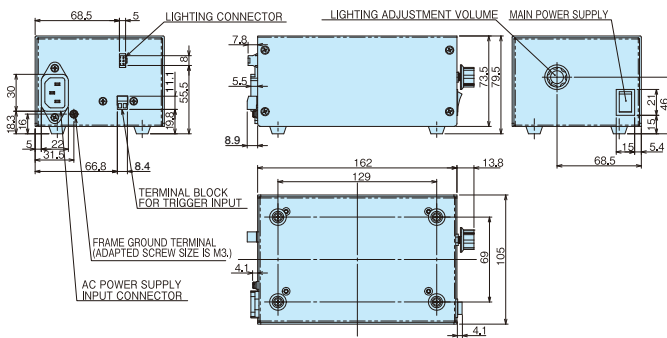

● FLV-ATC40405-□

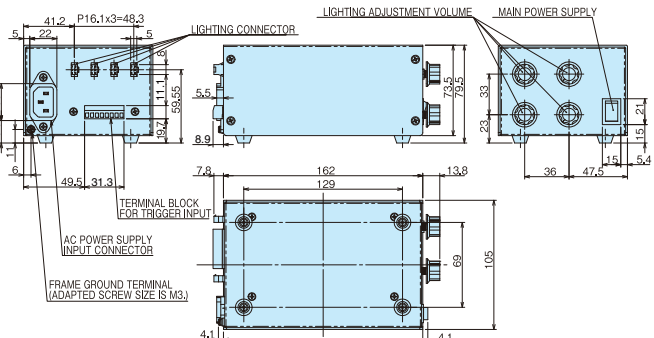

● Lighting Controller for Line Light: FLV-ATC26024-100V/-200V

Part Names and Functions

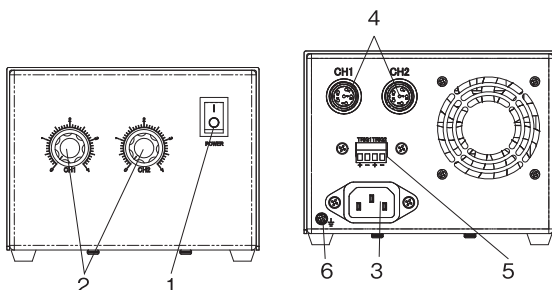

No.	Name	Description
1	Main power supply	Starts up the Controller when it is turned ON.
2	Lighting adjustment volume	Rotating the volume clockwise increases the emission intensity or counterclockwise decreases it.
3	AC power supply input connector	A terminal to supply AC power. Connect the provided AC input cable.
4	Lighting connector	Connects an LED lights.
5	Trigger input terminal block	A terminal block for lighting illumination trigger input from outside to each lighting.
6	Frame ground terminal	A terminal for frame ground. Connect the ground line.

Analog Lighting Controller for FLV Series FLV-ATC Series

Specifications

Item	Model	FLV-ATC26024-100V□ *1	FLV-ATC26024-200V□ *1
Number of connectable lightings		2	
Applicable light		FLV-LN series	
Power supply voltage *2		100 to 120 VAC, 50/60 Hz	200 to 240 VAC, 50/60 Hz
Current consumption		7 A max.	4 A max.
Electricity of connectable lighting		2ch total 240 W max. 120 W max. for 1ch	
Drive method		Constant voltage method	
Lighting method		Trigger lighting, Continuous lighting	
Intensity control method		Current light adjustment : 5 A max.	
Trigger lighting		Turning the light off in synchronization with input from the trigger input terminal	
Trigger lighting delay time		T_on: 500 μs max.	
External interface		Trigger input terminal block	
Dielectric strength		1500 VAC	50/60 Hz 1 min
Insulation resistance		20 MΩ (500 VDC)	
Ambient temperature		Operating: 0 to 40°C, Storage: -15 to 60°C (with no icing or condensation)	
Ambient humidity		Operating/storage: 35% to 85% (with no condensation)	
Degree of protection		IP20 (IEC60529)	
Vibration resistance (destructive)		10 to 150 Hz, (0.2 mm double amplitude) 80 min each in X, Y, and Z directions	
Shock resistance (destructive)		150 m/s ² 3 times each in 6 directions (up/down, left/right, forward/backward)	
Materials		Case: Aluminum	
Weight		Approx. 2.1 kg	
Accessories		Instruction sheet, AC input cable *1	
Applicable standards		EN: EN61326, EMC: No.2004/108/EC	

*1: The suffixed symbol of the model name means the plug type of the accessory cable. A model name with no suffix means type A.

*2: This product is the exclusive use for apparatus inclusion in the industrial machine field.

This product cannot be used for the connection to electric power equipment, such as a common residence, store, and small establishment, because of nonconformity with to Electrical Appliance and Material Safety Law (PSE).

Connecting to External Trigger Input Terminal Block

- Connection of this terminal block is not required if lighting illumination trigger input from outside is not used.

<Connection of trigger input terminal block>

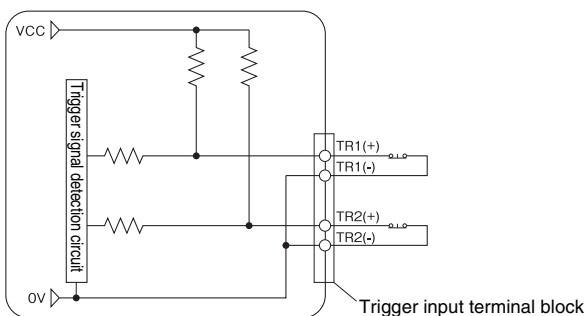

* Current flowing through the short circuit is less than 2 mA.

●FLV-ATC26024-□

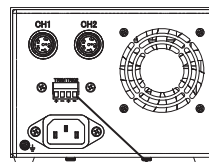

Trigger input terminal block CH1 to CH2

Short-circuiting (+) and (-) of TR1 to TR2 respectively makes the trigger input status OFF, turning the light OFF.
Releasing (+) and (-) makes the status ON, turning the light ON.

[Important]

- Make sure that excessive force is not imposed on the wire and terminal block.
- Do not install the product in which loads are constantly applied to the terminal block such as the wire being under tension.
- When wiring the terminal block, use an applicable cable (AWG 14 to 24, tip processing length: 7 mm).

Dimensions (Unit: mm)

●FLV-ATC26024-□

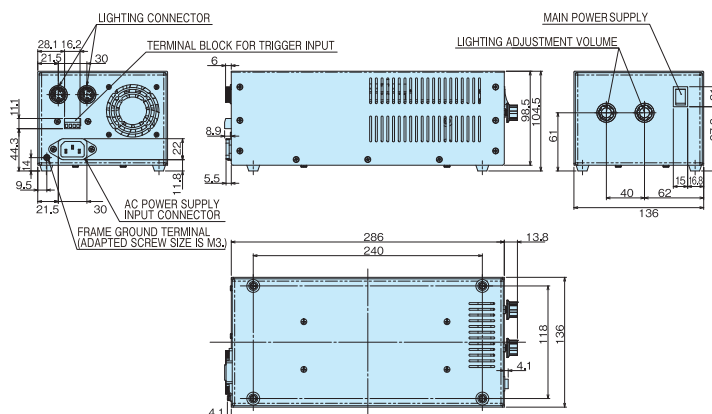

Direct Ring Light FL-DR Series

Clear Images with Industry's Best Level* of Brightness and Illumination over a Wide Field of View



*: Based on OMRON testing in November 2010.

Light
FL Series
High-brightness Models

Product Features

- High brightness in a small package.
- Wide range of working distance.

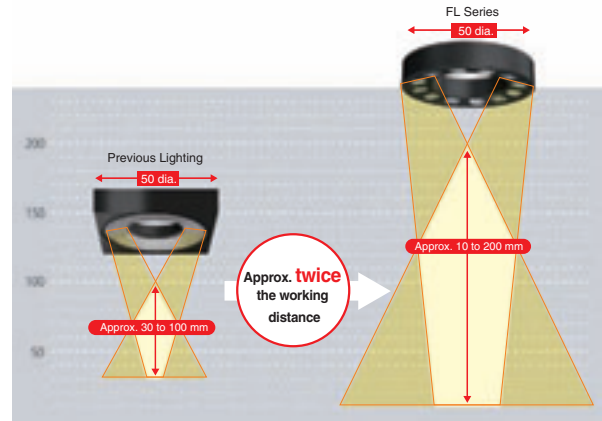
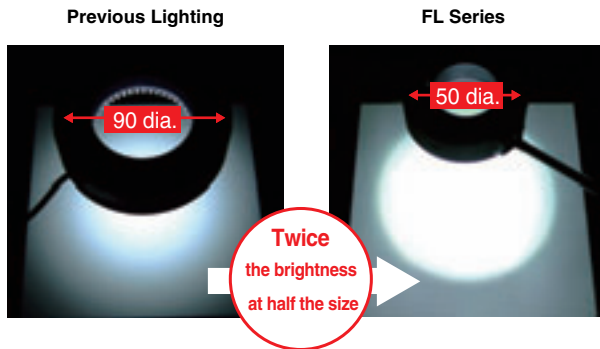

Illumination Structure

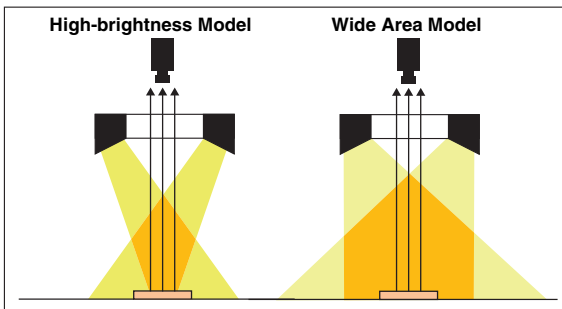

Lighting Intensity Distribution Characteristics

High-brightness Model (FL-DR50W-H)

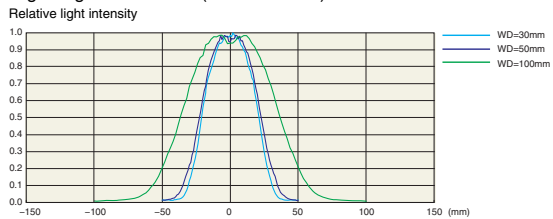

Wide Area Model (FL-DR50W)

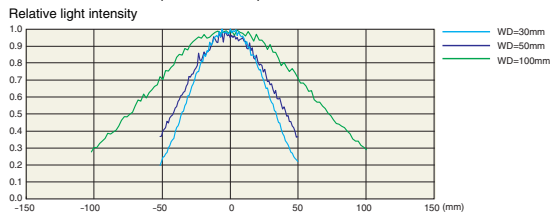

Applications

Previous Lighting

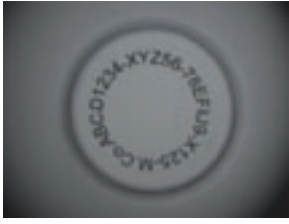

Faster lines make it necessary to increase shutter speeds, but then the clarity of workpiece images decreases.

FL-series

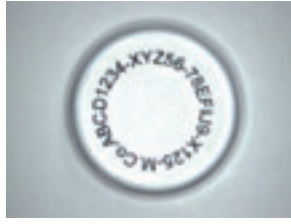

More than sufficient brightness is provided for high-speed lines.

Previous Lighting



It was necessary to create different inspection standards for each section.

FL-series



With uniform lighting from corner to corner, it is possible to inspect.

Ordering Information

Type	Model	Light Color
Wide Area Model	FL-DR32W	White LEDs
High-brightness Model	FL-DR32W-H	
Wide Area Model	FL-DR50W	
High-brightness Model	FL-DR50W-H	
Wide Area Model	FL-DR90W	
High-brightness Model	FL-DR90W-H	

Specifications

Model	Wide Area Model	High-brightness Model	Wide Area Model	High-brightness Model	Wide Area Model	High-brightness Model
	FL-DR32W	FL-DR32W-H	FL-DR50W	FL-DR50W-H	FL-DR90W	FL-DR90W-H
Light source	White LEDs					
Vibration resistance	10 to 150 Hz (Double amplitude: 0.7 mm), 80 min each in X, Y, and Z directions					
Shock resistance	150 m/s ² 3 times each in 6 directions					
Ambient temperature	Operating: 0 to 40°C, Storage: -15 to 60°C (with no icing or condensation)					
Ambient humidity	Operating/storage: 35% to 85% (with no condensation)					
Ambient atmosphere	No corrosive gases.					
Degree of protection	IEC60259 IP20					
Weight	Approx. 25 g		Approx. 30 g		Approx. 70 g	Approx. 80 g
Materials	Case and Lens :PC, Cable:Heat resistant, Connector:Thermoplastic resin with glass					
LED safety	Risk Group 2 (IEC 62471)					
Accessories	Instruction sheet					

The color of white LEDs can vary due to intrinsic characteristics. Confirm suitability for the application in advance.

Dimensions (Unit: mm)

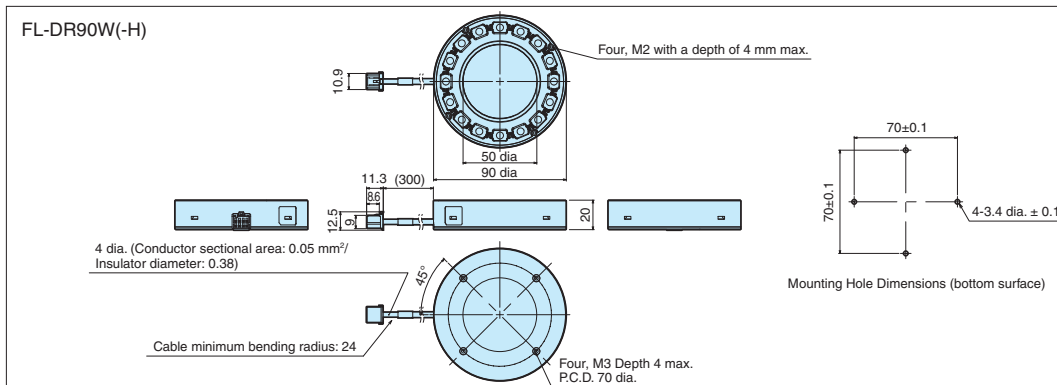
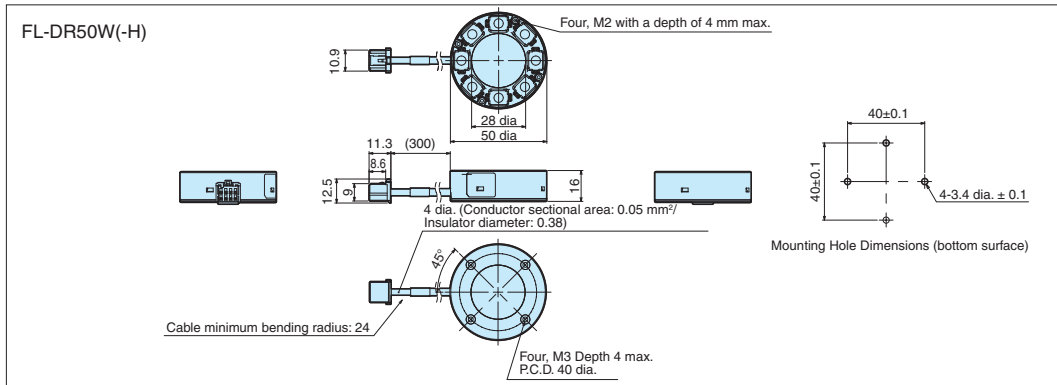
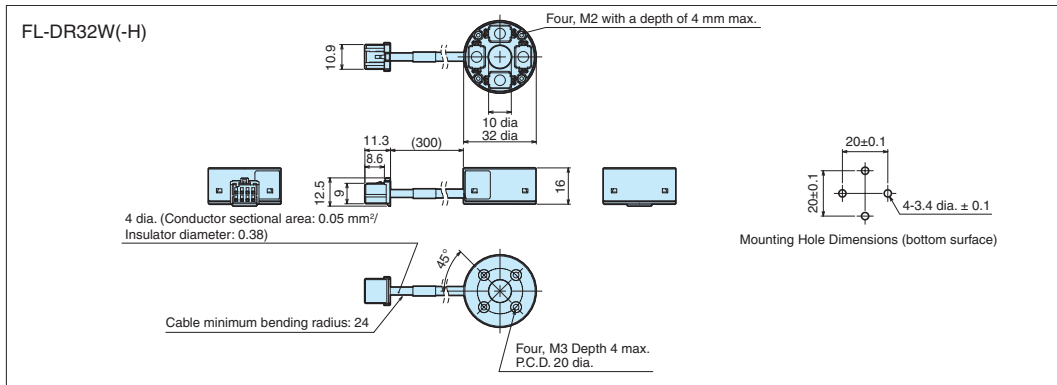

FL-BR Series

The highest level* of brightness in the industry.
This series is structured for adaptable wiring and mounting.



* Based on OMRON testing in November 2010.

Product Features

- High-brightness ODR lighting beyond the limitations of LEDs.
- Stable inspection even for high-speed applications.
- Bright even through a polarizing filter.
- Easy wiring, mounting, and adjustment.

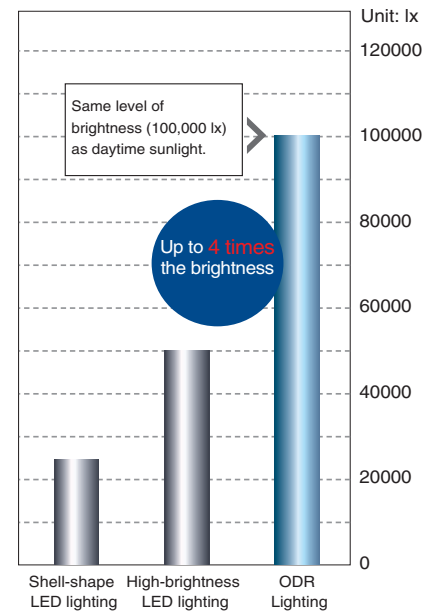

Wiring



The cable can extend from either direction, allowing for horizontal or vertical wiring layouts on the mounting surface.

Mounting and Adjustment



The light is structured for mounting with nuts to an arm on the back or side surfaces. Minute changes in the position can be achieved by sliding the light.



Specialized mounting brackets enable mounting at a flexible angle.

Illumination Structure

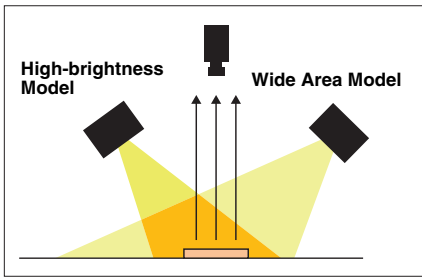

Lighting Intensity Distribution Characteristics

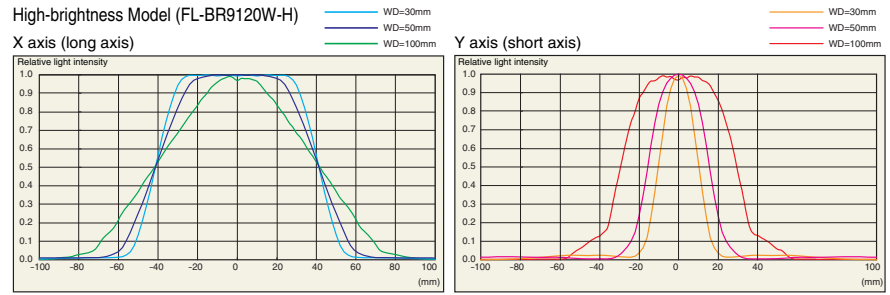

Wide Area Model (FL-BR9120W)

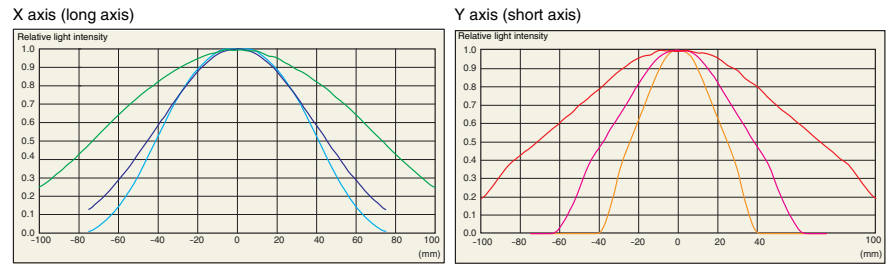

Applications

Standard Lighting



It is difficult to read characters with low contrast.

FL Series



Sharp images are created of both two-dimensional codes and characters.

Standard Lighting



Inspection is not possible because of workpiece blurring or a lack of brightness.

FL Series



Complete extraction of edges and characters.

Ordering Information

Type	Model	Light Color
Wide Area Model	FL-BR5020W	White LEDs
High-brightness Model	FL-BR5020W-H	
Wide Area Model	FL-BR9120W	
High-brightness Model	FL-BR9120W-H	
Wide Area Model	FL-BR13120W	
High-brightness Model	FL-BR13120W-H	

Specifications

Model	Wide Area Model	High-brightness Model	Wide Area Model	High-brightness Model	Wide Area Model	High-brightness Model
	FL-BR5020W	FL-BR5020W-H	FL-BR9120W	FL-BR9120W-H	FL-BR13120W	FL-BR13120W-H
Light source	White LEDs					
Vibration resistance	10 to 150 Hz (Double amplitude: 0.7 mm), 80 min each in X, Y, and Z directions					
Shock resistance	150 m/s ² 3 times each in 6 directions					
Ambient temperature	Operating: 0 to 40°C, Storage: -15 to 60°C (with no icing or condensation)					
Ambient humidity	Operating/storage: 35% to 85% (with no condensation)					
Ambient atmosphere	No corrosive gases.					
Degree of protection	IEC60259 IP20					
Weight	Approx. 40 g		Approx. 70 g		Approx. 100 g	
Materials	Case and Lens :PC, Cable:Heat resistant, Connector:Thermoplastic resin with glass					
LED safety	Risk Group 2 (IEC 62471)					
Accessories	Instruction sheet					

The color of white LEDs can vary due to intrinsic characteristics. Confirm suitability for the application in advance.

Dimensions (Unit: mm)

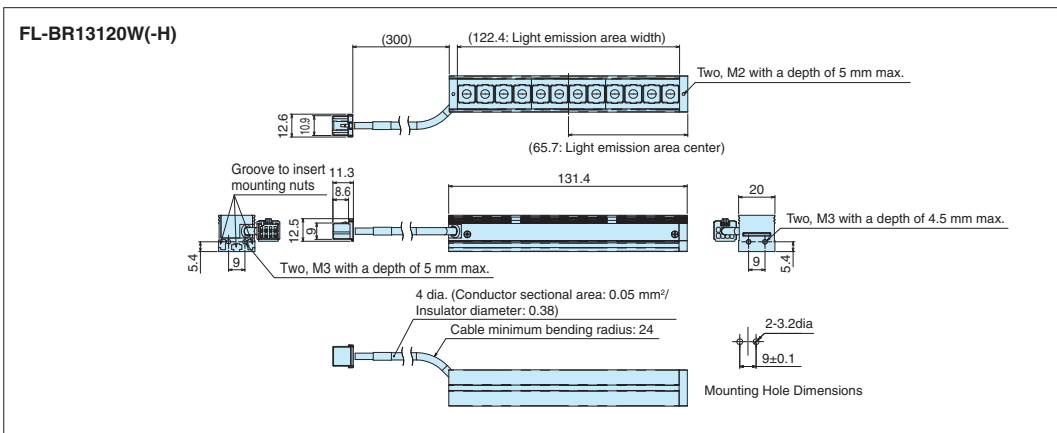
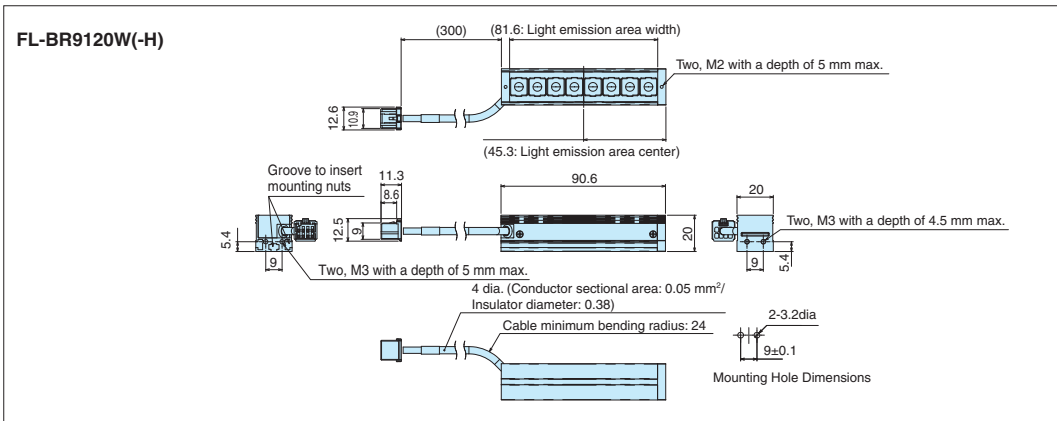
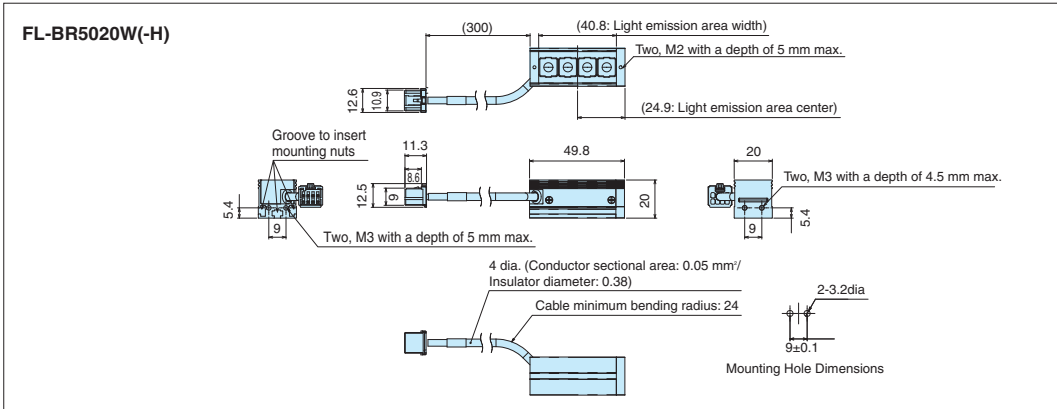

Digital Lighting Controller for FL-series

FL-STC Series

Small body is combined with the long cable at 25 m. Install in essentially any location.



Two-channel models

One-channel models

Light
FL Series
High-brightness Models

Product Features

● Easy Control and Adjustment of the Lighting

With a compact design small enough to fit in the palm of your hand, the Controller can be built into the control panel or in the gap between production lines.

By using the longest lighting cable in the industry (25 m), the Controller can be installed along with the image processing monitor in a variety of locations. It is possible to adjust the lighting while looking at the screen.

Connect to a Remote Control Panel



Mount to a DIN Rail underneath the Line or in the Gap between Tables



Lighting Control without Programming

This enables light emission synchronized with the camera using essentially any trigger, such as a photoelectric sensor. The Controller can be connected to an image processing device to control lighting without any programming on a PLC.

[Control Output]

- PNP/NPN models
- Power source: 24 V

[Lighting Emission Controls]

- Lighting triggers can be used individually for each channel.
- Lighting delay and lighting time can be controlled.

Intuitive Digital Light Controls

Digital adjustment of light emission makes it easy to reproduce the lighting environment after line switchovers.



The quantity of light is displayed digitally in 400 levels. Adjust the light in fine detail.

▲ Increases brightness

▼ Decreases brightness

Ordering Information

Type	Model	I/O specification	Input voltage
One-channel models	FL-STC10	NPN	24 VDC
	FL-STC15	PNP	
Two-channel models	FL-STC20	NPN	
	FL-STC25	PNP	

Specifications

Product type		One-channel models	Two-channel models		
I/O type		NPN	PNP	NPN	PNP
Model		FL-STC10	FL-STC15	FL-STC20	FL-STC25
Power supply voltage		24 VDC±10% (including ripple)			
Power consumption		36 W, 1.5 A max. (including the lighting section)		72 W, 3 A max. (including the lighting section)	
Number of output channels		1		2	
Applicable light		FL-□ Series			
Luminance control method	CONTINUOUS mode	While the Strobe Controller power source is ON, light is continuously emitted. PWM frequency: 100 kHz, Light adjustment: 400 levels			
	EXTERNAL TRIGGER mode	Lighting in synchronization with an external trigger input. Lighting duration: Continuous while the trigger is input, or 0.1 to 99.9 ms (set in 0.1-ms increments) PWM frequency: 100 kHz, Light adjustment: 400 levels			
	STOROBE mode	Lighting in synchronization with the external trigger input, but twice brighter than EXTERNAL TRIGGER mode. Lighting pulse width: 0.01 to 5 ms (light adjustment: 500 levels equivalent)			
Luminance adjustment	Key	Luminance control method and adjustment value: Slide switch and cross key setting			
	I/O	Luminance adjustment value: 9-bit binary input control			
External interface		Parallel I/O connector (D-sub 15-pin), Terminal block (external trigger input with 2 terminals, power source voltage input with 2 terminals)			
Ambient temperature		Operating: 0 to 40°C, Storage: -15 to 60°C (with no icing or condensation)			
Ambient humidity		Operating/storage: 35% to 85% (with no condensation)			
Vibration resistance		10 to 150 Hz (0.7 mm double amplitude), 80 min each in X, Y, and Z directions			
Shock resistance		150 m/s ² 3 times each in 6 direction (up/down, left/right, forward/backward)			
Materials		Case: PC			
Degree of protection		IEC60529 IP20			
Weight		Approx. 100 g			
Accessories		Instruction sheet, Terminal block connector			
Applicable standards		EN: 61326, EMC: No.2004/108/EC			

Dimensions (Unit: mm)

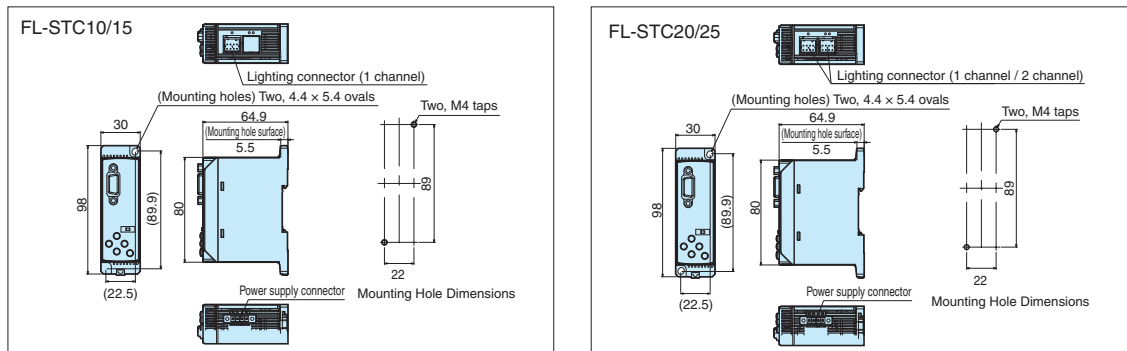

I/O Circuit Diagrams

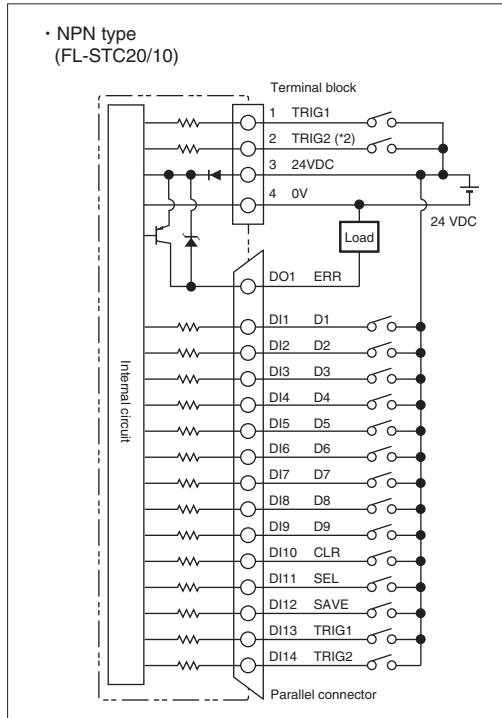

(*2) no use for FL-STC10

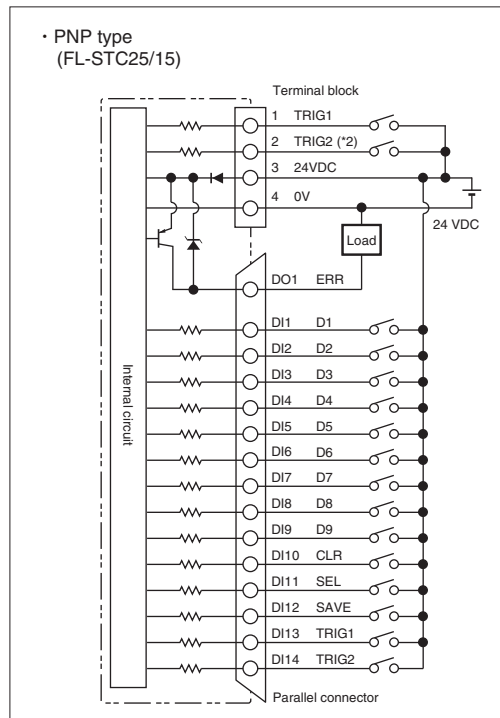

(*2) no use for FL-STC15

●Electrical Specifications

Output circuit	Input circuit
NPN Open-collector 30 VDC 50 mA max. ON: Residual voltage 1.2 V max. OFF: Leakage current 0.1 mA max.	ON: Short-circuited with 0 V or 1.5 V or less OFF: Open (Leakage current: 0.1 mA max.)

●Electrical Specifications

Output circuit	Input circuit
PNP Open-collector 50 mA max. ON: Residual voltage 1.2 V max. OFF: Leakage current 0.1 mA max.	ON: Supply voltage short-circuited or supply voltage within 1.5 v OFF: Open (Leakage current: 0.1 mA max.)

Wiring Diagram

PIN No.	Signal	I/O	Function
DI1	D1	Input	Data 1bit (low)
DI2	D2	Input	Data 2bit
DI3	D3	Input	Data 3bit
DI4	D4	Input	Data 4bit
DI5	D5	Input	Data 5bit
DI6	D6	Input	Data 6bit
DI7	D7	Input	Data 7bit
DI8	D8	Input	Data 8bit
DI9	D9	Input	Data 9bit (High)
DI10	CLR	Input	Error clear. (OFF→ON timing)
DI11	SEL	Input	Select setting CH. OFF=1CH, ON=2CH
DI12	SAVE	Input	Save data D9 - D1 to memory at the timing of "save" OFF→ON *3)
DI13	TRIG1	Input	CH1 Trigger Input (*1)(*2)
DI14	TRIG2	Input	CH2 Trigger Input (*1)(*2)
DO1	ERR	Output	ON at the Error happens

- *1. 1 and 2pin of terminal block have Lighting trigger. Make sure isolate another trigger terminal when you use one trigger terminal.
- *2. Prevent from chattering, otherwise the lighting timing would be missed.
- *3. Memory function "ON": The data stored in FLASH memory .
Memory function "OFF" : The data stored in RAM memory .

Camera-mount Lighting Controller for FL Series

FL-TCC Series

Camera-mount Compact Lighting Controller Which Requires No Power Supply Nor Lighting Control



Product Features

- No separate power supply is required because the power is supplied from the Camera.
- Light is emitted when a trigger signal is received from the Camera.
- Simple connection between the Camera and the Lighting with a single cable

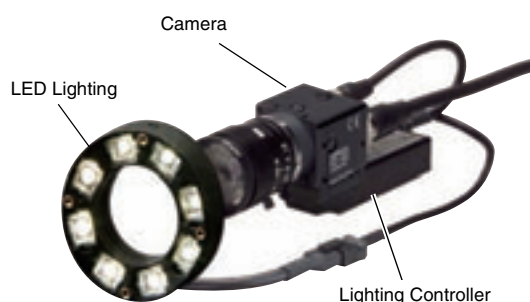

Ordering Information

Item	Model	Weight
Lighting Controller	FL-TCC1	Approx. 110 g
Camera Mounting Spacer	FL-TCC1-XSP	Approx. 10 g
Camera Mounting Attachment	FL-TCC1-XAT	Approx. 20 g

Specifications

●Lighting Controller

Product type	Lighting Controller	
Model	FL-TCC1	
Input voltage	Supplied from applicable camera.	
Applicable camera	FH-S/SC/S02/SC02/S04/SC04, FZ-S/SC/S2M/SC2M/S5M2/SC5M2/SH/SHC/SF/SFC/SP/SPC, FQ-MS series and others.	
Applicable controller	FH series, FZ5 series, FZ4 series and others.	
Power consumption	10 W, 0.9 A max. (including the lighting section)	
Number of output channels	1	
Applicable lighting	FL-□ series	
Luminance control method	Functions	PWM frequency: 100 kHz, Light adjustment: 255 levels (set with the Controller)
	Trigger lighting	Lighting ON synchronized with trigger input timing from the Controller. (Auto setting in accordance with the shutter speed.)
	Trigger lighting delay time	Ton: 30 μs max. (Trigger ready μs) Toff: 10 μs max.
External interface	Dedicated communication connector	
Ambient temperature	Operating: 0 to 50°C, Storage: -15 to 60°C (with no icing or condensation)	
Ambient humidity	Operating/storage: 35% to 85% (with no condensation)	
Vibration resistance	10 to 55 Hz, (0.7 mm double amplitude) 80 min each in X, Y, and Z directions	
Shock resistance	150 m/s ² 3 times each in 6 directions (up/down, left/right, forward/backward)	
Materials	Case: SECC, Cable: PVC	
Degree of protection	IP20 (IEC60529)	
Weight	Approx. 110 g	
Accessories	Instruction sheet, Insulation sheet, Mounting screw (M2 × 6 mm) × 4	
Applicable standards	EN: EN61326, EMC: No.2004/108/EC	

Camera-mount Lighting Controller for FL Series FL-TCC Series

Dimensions (Unit: mm)

● Lighting Controller FL-TCC1

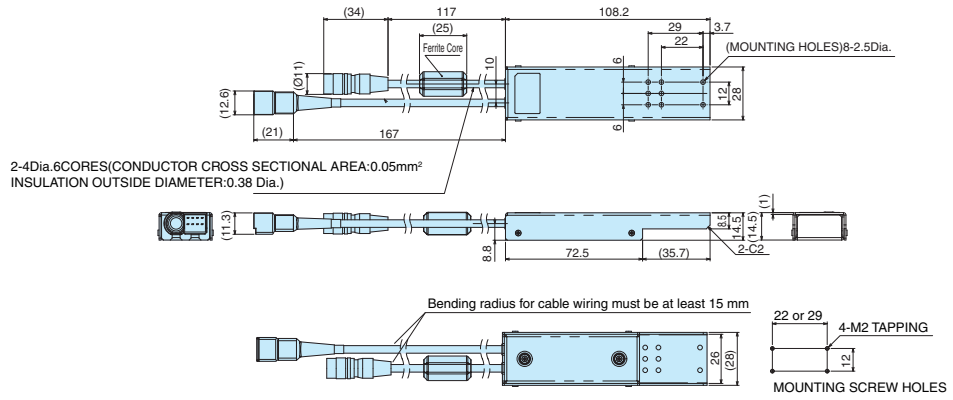

● Options

Camera Mounting Spacer FL-TCC1-XSP (sold separately)

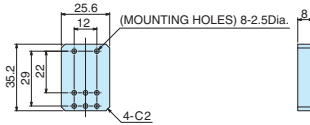

Camera Mounting Attachment FL-TCC1-XAT (sold separately)

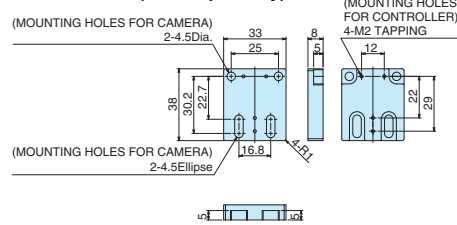

Light
FL Series
High-brightness Models

Cable/Diffusion Plate/Mounting Bracket

Cable

For FLV series

Ordering Information

Type	Model	Cable Length	Weight	Dimension
Extension Cable for Standard Light *1	FLV-XC1	1 m	Approx. 20 g	A
	FLV-XC2	2 m	Approx. 40 g	
	FLV-XC3	3 m	Approx. 50 g	
	FLV-XC5	5 m	Approx. 80 g	
Extension Cable for Spot Light	FLV-XC1EP	1 m	Approx. 20 g	B
	FLV-XC2EP	2 m	Approx. 40 g	
	FLV-XC3EP	3 m	Approx. 50 g	
	FLV-XC5EP	5 m	Approx. 80 g	
Extension Cable for Line Light	FLV-XC1LN	1 m	Approx. 200 g	C
	FLV-XC2LN	2 m	Approx. 270 g	
	FLV-XC3LN	3 m	Approx. 320 g	
	FLV-XC5LN	5 m	Approx. 440 g	
Branch Cable for Standard Light *1	FLV-XC1S2	1 m	Approx. 30 g	D
	FLV-XC2S2	2 m	Approx. 50 g	
	FLV-XC3S2	3 m	Approx. 80 g	
	FLV-XC5S2	5 m	Approx. 120 g	

*1. Standard light means all FLV-series Lights excluding the FLV-EP-series Spot Lights and the FLV-LN-series Line Lights.

Dimensions (Unit: mm)

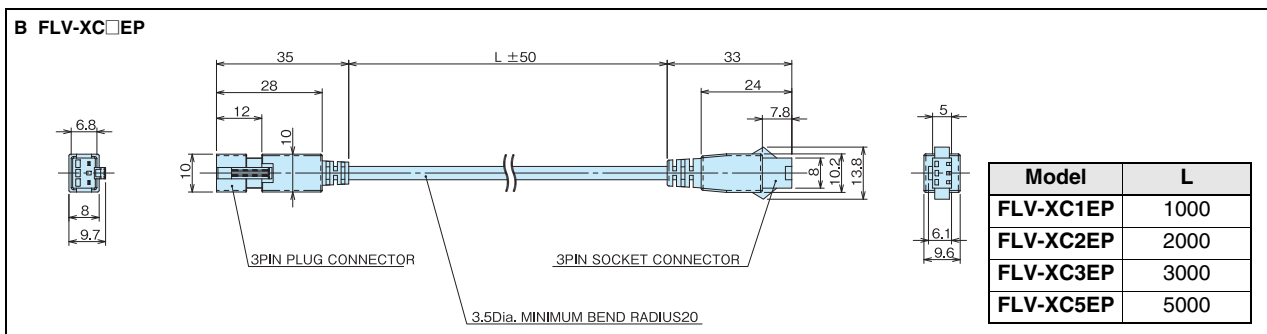
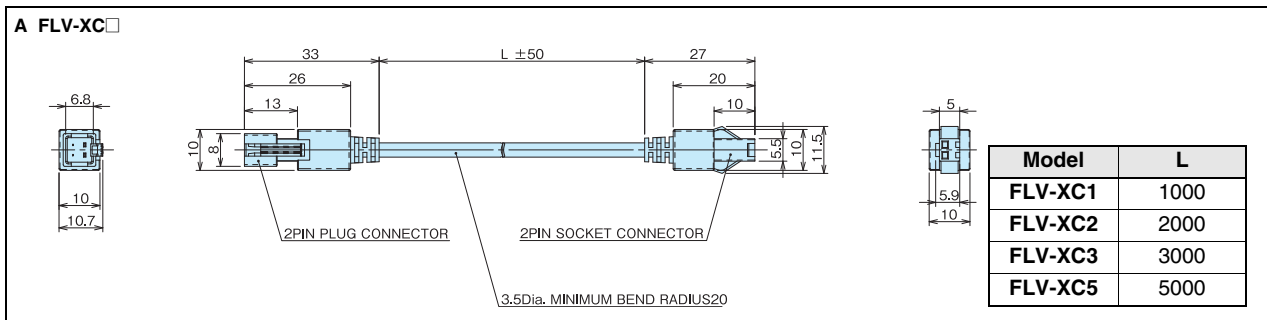

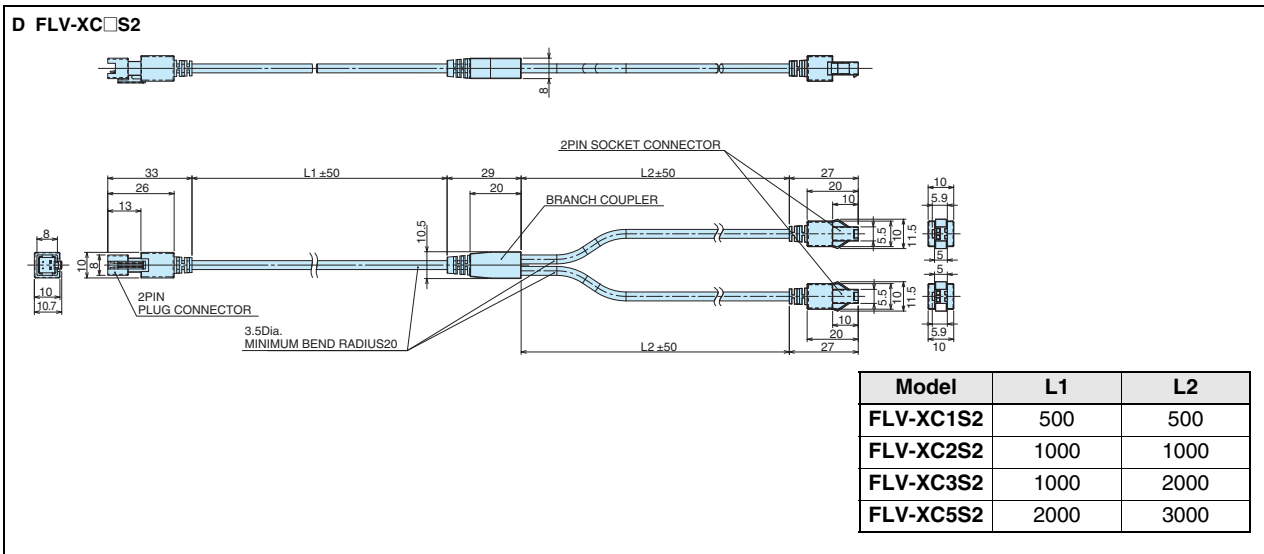
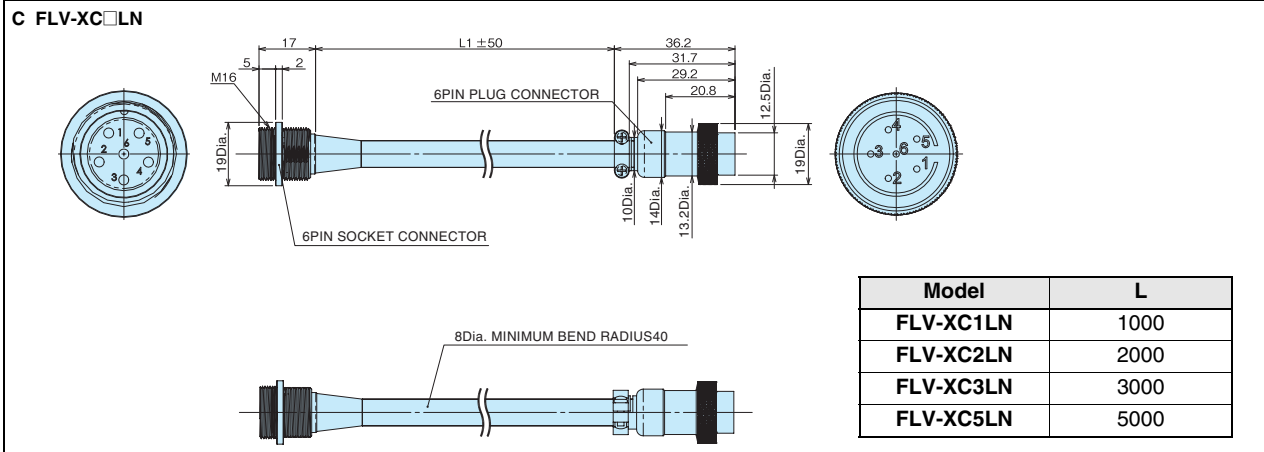

Options

For FL series

Ordering Information



● **Extension Cable, Standard Cable**

Model	Cable Length	Weight
FL-XC1	1 m	Approx. 50 g
FL-XC2	2 m	Approx. 80 g
FL-XC3	3 m	Approx. 120 g
FL-XC5	5 m	Approx. 190 g
FL-XC10	10 m	Approx. 400 g
FL-XC25	25 m	Approx. 1000 g

● **Extension Cable, Bend resistant Cable**

Model	Cable Length	Weight
FL-XC1R	1 m	Approx. 60 g
FL-XC2R	2 m	Approx. 100 g
FL-XC3R	3 m	Approx. 150 g
FL-XC5R	5 m	Approx. 240 g
FL-XC10R	10 m	Approx. 500 g
FL-XC25R	25 m	Approx. 1200 g

● **Parallel Cable**

Model	Cable Length	Weight
FL-XCP2	2 m	Approx. 180 g

Dimensions (Unit: mm)

● **Extension Cable**

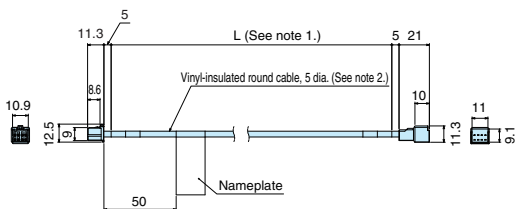

Note 1. Depends on the cable length.
 Note 2. The cable diameter is 6.2 for bend resistant cable.

● **Parallel Cable**

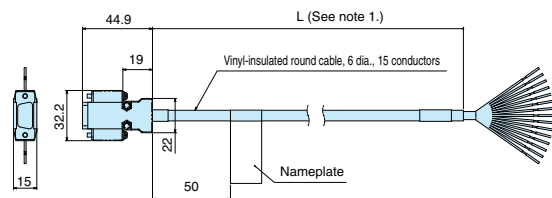

Note 1. Depends on the cable length.

Diffusion Plate and Polarization Plate

For FLV series

Ordering Information

● Diffusion Plate

Type	Model	Connectable Lighting
For FLV-DR-series Direct Ring Light	FLV-DR3220DF	FLV-DR3220□
	FLV-DR5030DF	FLV-DR5030□
	FLV-DR6030DF	FLV-DR6030UV
	FLV-DR6615DF	FLV-DR6615□
	FLV-DR7000DF	FLV-DR7000□
	FLV-DR7030DF	FLV-DR7030□
	FLV-DR7530DF	FLV-DR7530UV
	FLV-DR9000DF	FLV-DR9000□
	FLV-DR9030DF	FLV-DR9030□
	FLV-DR9215DF	FLV-DR9215□
FLV-DR12030DF	FLV-DR12030□	
For FLV-DL-series Low Angle Ring Light	FLV-DL5890DF	FLV-DL5890□
	FLV-DL7260DF	FLV-DL7260□
	FLV-DL12060DF	FLV-DL12060□
	FLV-DL15060DF	FLV-DL15060□
For FLV-BR-series Bar Light	FLV-BR6022DF	FLV-BR6022□
	FLV-BR6424DF	FLV-BR6424UV
	FLV-BR8532DF	FLV-BR8532□
	FLV-BR11222DF	FLV-BR11222□
	FLV-BR11624DF	FLV-BR11624UV
	FLV-BR14030DF	FLV-BR14030□
	FLV-BR15020DF	FLV-BR15020□
	FLV-BR21222DF	FLV-BR21222□
	FLV-BR21230DF	FLV-BR21230□
	FLV-BR38037DF	FLV-BR38037□
FLV-BR48031DF	FLV-BR48031□	

● Polarization Plate

Type	Model	Connectable Lighting
For FLV-DR-series Direct Ring Light	FLV-DR3220PL	FLV-DR3220□
	FLV-DR5030PL	FLV-DR5030□
	FLV-DR6615PL	FLV-DR6615□
	FLV-DR7000PL	FLV-DR7000□
	FLV-DR7030PL	FLV-DR7030□
	FLV-DR9000PL	FLV-DR9000□
	FLV-DR9030PL	FLV-DR9030□
	FLV-DR9215PL	FLV-DR9215□
For FLV-DL-series Low Angle Ring Light	FLV-DL7260PL	FLV-DL7260□
	FLV-DL12060PL	FLV-DL12060□
	FLV-DL15060PL	FLV-DL15060□
For FLV-BR-series Bar Light	FLV-BR6022PL	FLV-BR6022□
	FLV-BR8532PL	FLV-BR8532□
	FLV-BR11222PL	FLV-BR11222□
	FLV-BR14030PL	FLV-BR14030□
	FLV-BR15020PL	FLV-BR15020□
	FLV-BR21222PL	FLV-BR21222□
	FLV-BR21230PL	FLV-BR21230□
	FLV-BR38037PL	FLV-BR38037□
	FLV-BR48031PL	FLV-BR48031□
	FLV-BR6022PL-V	FLV-BR6022□
	FLV-BR8532PL-V	FLV-BR8532□
	FLV-BR11222PL-V	FLV-BR1122□
	FLV-BR14030PL-V	FLV-BR14030□
	FLV-BR15020PL-V	FLV-BR15020□
	FLV-BR21222PL-V	FLV-BR21222□
	FLV-BR21230PL-V	FLV-BR21230□
	FLV-BR38037PL-V	FLV-BR38037□
FLV-BR48031PL-V	FLV-BR48031□	

Polarization
direction:
Long sidePolarization
direction:
Short side

For FL series

Ordering Information



●Diffusion Plate

Type	Model	Dimensions (mm)
Bar Lighting	FL-BR5020DF	49.8×18×4
	FL-BR9120DF	90.6×18×4
	FL-BR13120DF	131.4×18×4

Type	Model	Outer diameter/Inner diameter/Thickness (mm)
Direct Ring Lighting	FL-DR32DF	32 dia./10 dia./4
	FL-DR50DF	50 dia./28 dia./4
	FL-DR90DF	90 dia./50 dia./4

●Polarization Plate

Type	Model	Outer diameter/Inner diameter/Thickness (mm)
Direct Ring Lighting	FL-DR32PL	32 dia./10 dia./2
	FL-DR50PL	50 dia./28 dia./2
	FL-DR90PL	90 dia./50 dia./2

Mounting Bracket

For FL series

Ordering Information

Type	Model
Bar Lighting	FL-XBK1

Dimensions (Unit: mm)

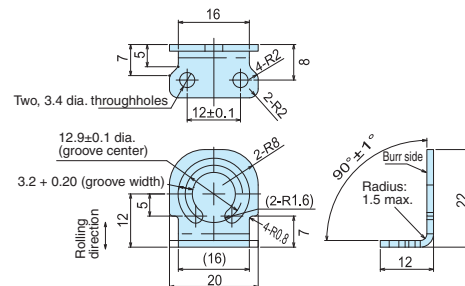

Burs must extend less than 0.1 mm.

SV-V Series

- Standard CCTV lens.
- Lineup of 11 models with focal lengths ranging from 3.5 to 100 mm.
- Lock screws for focus and iris.
- More robust structure designed for machine vision.
- Lower distortion and higher resolution than previous CCTV lenses.



Ordering Information

Series	Model	Dimension	Focal distance (mm)	Aperture (F No)	Field of view (V × H)	Closest distance (mm)	Filter size	Weight (g)	Total length (mm)	Maximum compatible CCD
C-mount Lens for 1/3-inch image sensor (Recommend: FZ-S□ FZ-SH□ FH-S□)	3Z4S-LE SV-03514V	A	3.5	1.4 to Close	77.8°× 105.9°	200	-	53	30.4	1/3 inch
	3Z4S-LE SV-04514V	B	4.5	1.4 to Close	59.7°× 79.9°	200	-	53	29.5	1/3 inch
	3Z4S-LE SV-0614V	C	6	1.4 to Close	42.3°× 54.6°	200	M27.0 P0.5	49	30	1/3 inch
	3Z4S-LE SV-0813V	D	8	1.3 to Close	44.6°× 57.3°	200	M25.5 P0.5	55	34	1/3 inch
	3Z4S-LE SV-1214V	E	12	1.4 to Close	21.9°× 38.9°	300	M27.0 P0.5	44	29.5	1/3 inch
	3Z4S-LE SV-1614V	F	16	1.4 to Close	22.8°× 30.1°	400	M27.0 P0.5	34	24	1/3 inch
	3Z4S-LE SV-2514V	G	25	1.4 to Close	14.9°× 19.8°	500	M27.0 P0.5	36	24.5	1/3 inch
	3Z4S-LE SV-3518V	H	35	1.8 to Close	10.8°× 14.4°	300	M27.0 P0.5	47	33.5 to 37.5	1/3 inch
	3Z4S-LE SV-5018V	I	50	1.8 to Close	7.9°× 10.5°	1000	M30.5 P0.5	67	37.0 to 39.4	1/3 inch
	3Z4S-LE SV-7527V	J	75	2.7 to Close	3.6°× 4.8°	1000	M30.5 P0.5	76	42.0 to 44.4	1/3 inch
	3Z4S-LE SV-10035V	K	100	3.5 to Close	2.9°× 3.8°	1000	M30.5 P0.5	79	43.9 to 46.3	1/3 inch

Dimensions (Unit: mm)

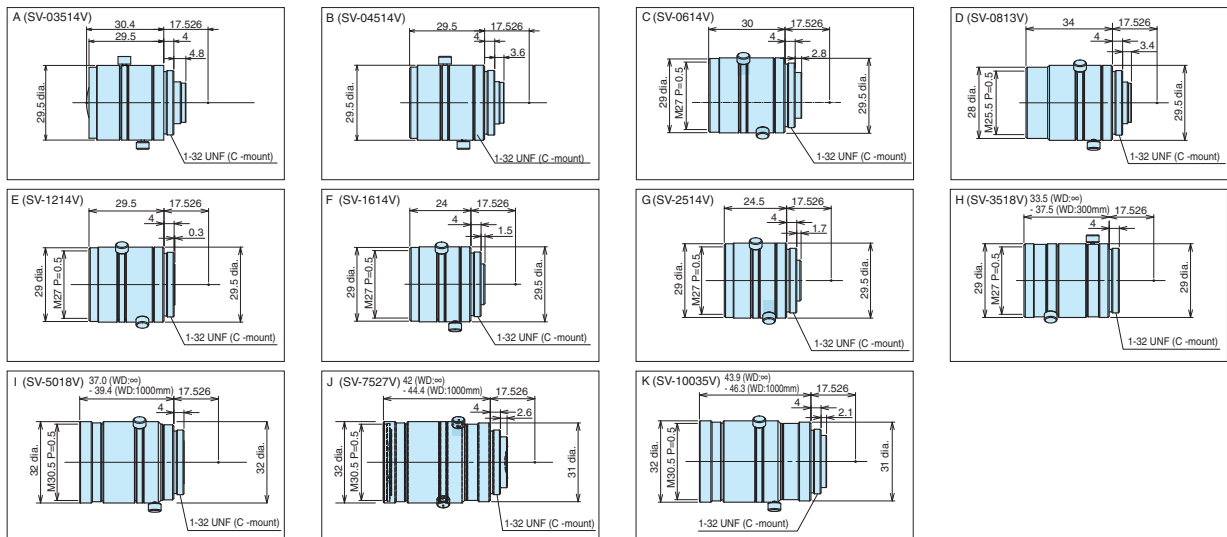

SV-H/VVS-H1 Series

- High-resolution lens for megapixel camera.
- Lineup of 7 models for 2/3-inch cameras, with focal lengths ranging from 6 to 100 mm, and 9 models for 1-inch cameras.
- Lock screws for focus and iris.
- Short expose time with bright F number of 1.4 for high-speed CMOS cameras.
- Compact design but minimized decrease in distortion and brightness.



SV-H Series for 2/3-inch image sensor



VS-H1 Series for 1-inch image sensor

Ordering Information

Series	Model	Dimension	Focal distance (mm)	Aperture (F No)	Field of view (V × H)	Closest distance (mm)	Filter size	Weight (g)	Total length (mm)	Maximum compatible CCD
C-mount Lens for 2/3-inch image sensor (Recommend: FZ-S□2M FZ-S□5M2)	3Z4S-LE SV-0614H	A	6	1.4 to 16	56.8° × 71.5°	100	M40.5 P0.5	145	57.5	2/3 inch
	3Z4S-LE SV-0814H	B	8	1.4 to 16	44.9° × 57.6°	100	M35.5 P0.5	125	52.5	2/3 inch
	3Z4S-LE SV-1214H	C	12	1.4 to 16	30.2° × 39.6°	100	M27 P0.5	85	51	2/3 inch
	3Z4S-LE SV-1614H	D	16	1.4 to 16	23.1° × 30.6°	100	M27 P0.5	85	47.5	2/3 inch
	3Z4S-LE SV-2514H	E	25	1.4 to 16	15.0° × 20.0°	150	M27 P0.5	65	36	2/3 inch
	3Z4S-LE SV-3514H	F	35	1.4 to 16	10.8° × 14.3°	200	M35.5 P0.5	150	45.5	2/3 inch
	3Z4S-LE SV-5014H	G	50	1.4 to 16	7.5° × 10.0°	300	M40.5 P0.5	170	57.5	2/3 inch
C-mount Lens for 1-inch image sensor* (Recommend: FH-S□02 FH-S□04)	3Z4S-LE SV-7525H	H	75	2.5 to Close	2/3" = 5.0° × 6.7° 1" = 7.3° × 9.7°	1200	M34.0 P0.5	85	49.5 to 54.6	1 inch
	3Z4S-LE SV-10028H	I	100	2.8 to Close	2/3" = 3.9° × 5.1° 1" = 5.6° × 7.5°	2000	M37.5 P0.5	105	66.5 to 71.6	1 inch
	3Z4S-LE VS-0618H1	J	6	1.8 to 16	77.9° × 94.8°	100	NA	200	57.2	1 inch
	3Z4S-LE VS-0814H1	K	8	1.4 to 16	62.8° × 79.3°	100	M55.0 P0.75	170	59	1 inch
	3Z4S-LE VS-1214H1	L	12	1.4 to 16	44.0° × 56.9°	300	M35.5 P0.5	140	48 to 48.5	1 inch
	3Z4S-LE VS-1614H1	M	16	1.4 to 16	33.7° × 44.3°	300	M30.5 P0.5	110	42.5 to 43.3	1 inch
	3Z4S-LE VS-2514H1	N	25	1.4 to 16	21.5° × 28.5°	300	M30.5 P0.5	90	33.5 to 35.6	1 inch
3Z4S-LE VS-3514H1	O	35	1.4 to 16	15.6° × 20.7°	300	M30.5 P0.5	100	35 to 39.1	1 inch	
3Z4S-LE VS-5018H1	P	50	1.8 to 16	11.0° × 14.6°	500	M40.5 P0.5	135	44.5 to 49.5	1 inch	

* 3Z4S-LE SV-7525H with focal length of 75 mm and 3Z4S-LE SV-10028H with focal length of 100 mm are also available.

Dimensions (Unit: mm)

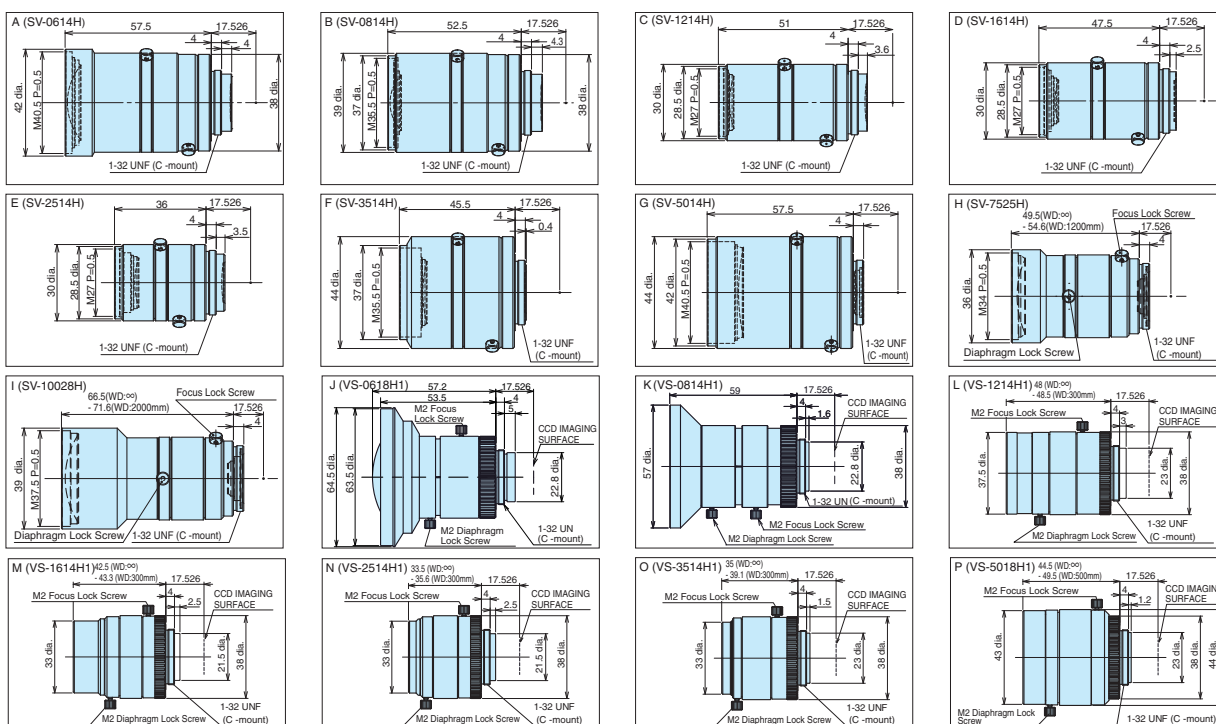

Vibrations and Shocks Resistant for C-mount cameras

VS-MC Series

- Lineup of 7 models with focal lengths ranging from 15 to 75 mm.
- A lock ring locking the surface and the improved design of internal structure increase resistance to vibration in comparison to the previous model with a lock screw locking a point.
This enables application in environments where the point-locked lens is moved under the effects of ambient vibration.
- Install in narrow space without a lock screw.



Ordering Information

Series	Model	Dimension	Focal distance (mm)	Aperture (fixed F No.)	Maximum outer diameter (mm)	Total length (mm)	Filter size	WD (mm)	Depth of field *1 (mm)	Maximum compatible CCD
Vibrations and Shocks Resistant C-mount Lens for 2/3-inch image sensor (Recommend: FZ-S□ FZ-SH□ FZ-S□2M FZ-S□5M2 FH-S□)	3Z4S-LE VS-MC15	A	15	2	31 dia.	25.4 to 29.5	M27.0 P0.5	492.2 67.3 42.3	183.1 4.8 2.3	2/3 inch
	3Z4S-LE VS-MC15-FNO56			5.6	31 dia.	25.4 to 29.5	M27.0 P0.5	492.2 67.3 42.3	512.7 13.4 6.5	
	3Z4S-LE VS-MC15-FNO80			8	31 dia.	25.4 to 29.5	M27.0 P0.5	492.2 67.3 42.3	732.4 13.4 9.2	
	3Z4S-LE VS-MC20	B	20	2	31 dia.	23.0 to 30.5	M27.0 P0.5	516.5 81.0 49.8	110.8 3.4 1.5	2/3 inch
	3Z4S-LE VS-MC20-FNO56			5.6	31 dia.	23.0 to 30.5	M27.0 P0.5	516.5 81.0 49.8	291.2 9.0 3.9	
	3Z4S-LE VS-MC20-FNO80			8	31 dia.	23.0 to 30.5	M27.0 P0.5	516.5 81.0 49.8	416.0 12.8 5.6	
	3Z4S-LE VS-MC25N	C	25	2	31 dia.	26.5 to 38.0	M27.0 P0.5	513.9 106.0 54.9	67.2 3.2 1.0	2/3 inch
	3Z4S-LE VS-MC25N-FNO56			5.6	31 dia.	26.5 to 38.0	M27.0 P0.5	513.9 106.0 54.9	188.2 9.0 2.7	
	3Z4S-LE VS-MC25N-FNO80			8	31 dia.	26.5 to 38.0	M27.0 P0.5	513.9 106.0 54.9	268.8 12.8 3.8	
	3Z4S-LE VS-MC30	D	30	2	31 dia.	24.0 to 35.7	M27.0 P0.5	514.6 214.5 81.1	47.1 8.2 1.1	2/3 inch
	3Z4S-LE VS-MC30-FNO56			5.6	31 dia.	24.0 to 35.7	M27.0 P0.5	514.6 214.5 81.1	131.9 22.9 3.2	
	3Z4S-LE VS-MC30-FNO80			8	31 dia.	24.0 to 35.7	M27.0 P0.5	514.6 214.5 81.1	188.4 32.7 4.6	
	3Z4S-LE VS-MC35	E	35	1.9	31 dia.	32.0 to 45.7	M27.0 P0.5	163.5 145.5 82.7	2.8 2.2 0.6	2/3 inch
	3Z4S-LE VS-MC35-FNO56			5.6	31 dia.	32.0 to 45.7	M27.0 P0.5	163.5 145.5 82.7	8.4 6.5 1.7	
	3Z4S-LE VS-MC35-FNO80			8	31 dia.	32.0 to 45.7	M27.0 P0.5	163.5 145.5 82.7	11.9 9.2 2.5	

Vibrations and Shocks Resistant for C-mount cameras VS-MC Series

Series	Model	Dimension	Focal distance (mm)	Aperture (fixed F No.)	Maximum outer diameter (mm)	Total length (mm)	Filter size	WD (mm)	Depth of field *1 (mm)	Maximum compatible CCD	
Vibrations and Shocks Resistant C-mount Lens for 2/3-inch image sensor (Recommend: FZ-S□, FZ-SH□, FZ-S□2M, FZ-S□5M2, FH-S□)	3Z4S-LE VS-MC50	F	50	2	31 dia.	44.5 to 63.9	M27.0 P0.5	625.8	33.8	2/3 inch	
	3Z4S-LE VS-MC50-FNO56			5.6	31 dia.	44.5 to 63.9	M27.0 P0.5	262.4	6.0		
				3Z4S-LE VS-MC50-FNO80	8	31 dia.	44.5 to 63.9	M27.0 P0.5	121.1		1.3
					3Z4S-LE VS-MC75	3.8	31 dia.	70.0 to 105.5	M27.0 P0.5		625.8
	3Z4S-LE VS-MC75-FNO56			5.6		31 dia.	70.0 to 105.5	M27.0 P0.5	262.4		13.4
				3Z4S-LE VS-MC75-FNO80		8	31 dia.	70.0 to 105.5	M27.0 P0.5		121.1
	G	75	3Z4S-LE VS-MC75		3.8	31 dia.	70.0 to 105.5	M27.0 P0.5	563.0	17.7	2/3 inch
					3Z4S-LE VS-MC75-FNO56	5.6	31 dia.	70.0 to 105.5	M27.0 P0.5	404.4	
				3Z4S-LE VS-MC75-FNO80		8	31 dia.	70.0 to 105.5	M27.0 P0.5	153.8	
			3Z4S-LE VS-MC75-FNO56		5.6	31 dia.	70.0 to 105.5	M27.0 P0.5	563.0	26.1	
					3Z4S-LE VS-MC75-FNO80	8	31 dia.	70.0 to 105.5	M27.0 P0.5	404.4	
			3Z4S-LE VS-MC75-FNO80	G		75	8	31 dia.	70.0 to 105.5	M27.0 P0.5	
404.4	19.2										
153.8	2.7										

Note: Vibrations and Shocks Resistant Lenses for 1-inch image sensors are also available. Ask your OMRON representative for details.

*1: Calculated using a permissible circle of confusion diameter of 0.04 mm.

Dimensions (Unit: mm)

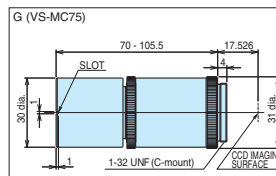
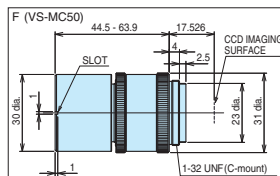
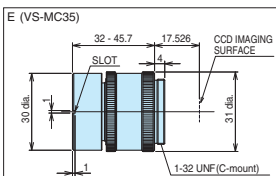
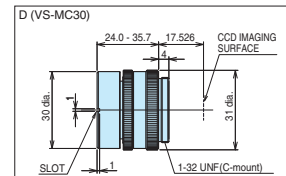
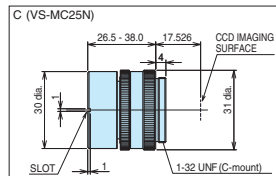
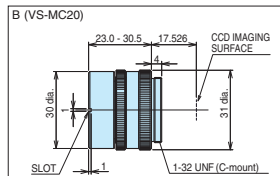
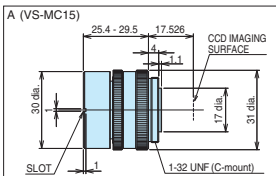

Standard Lens for M42-mount cameras

VS-L/M42-10 Series

- Wide variety of lenses with focal lengths ranging from 18 to 100 mm.
- Hexagon socket head cap screws for focus and aperture lock screws can be tightened more than finger tight. This ensures vibration resistance even when large diameter lenses are used.



Ordering Information

Series	Model	Dimension	Focal distance (mm)	Aperture (F No)	Optical magnification	Closest distance (mm)	Filter size	Weight (g)	Total length (mm)	Maximum compatible CCD
Standard lens for large image sensor (Recommend: FH-S□12)	3Z4S-LE VS-L1828/M42-10	A	18	2.8 to 16	0.025x to 0.12x	137.9	M55.0 P0.75	330	94	1.8 inch
	3Z4S-LE VS-L2526/M42-10	B	25	2.6 to 16	0.025x to 0.12x	198.1	M55.0 P0.75	240	80	1.8 inch
	3Z4S-LE VS-L3528/M42-10	C	35	2.8 to 16	0.05x to 0.3x	112.8	M62.0 P0.75	345	108	1.8 inch
	3Z4S-LE VS-L5028/M42-10	D	50	2.8 to 16	0.05x to 0.3x	181.4	M62.0 P0.75	285	94.5	1.8 inch
	3Z4S-LE VS-L8540/M42-10	E	85	4.0 to 16	0.1x to 0.35x	285.0	M52.0 P0.75	340	129.5	1.8 inch
	3Z4S-LE VS-L10028/M42-10	F	100	2.8 to 16	0.05x to 0.3x	409.0	M52.0 P0.75	350	134.5	1.8 inch

Note: Vibrations and Shocks Resistant Lenses for M42-mount cameras are also available. Ask your OMRON representative for details.

Dimensions (Unit: mm)

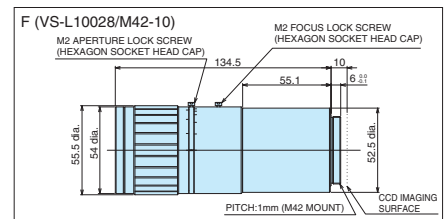
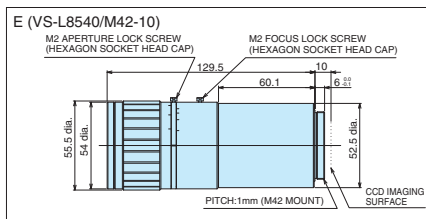
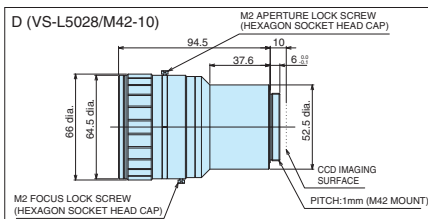
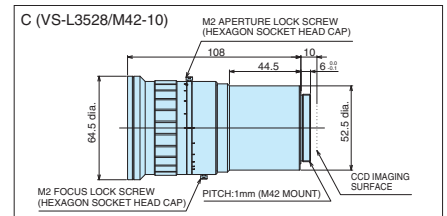
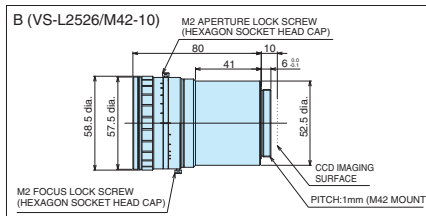
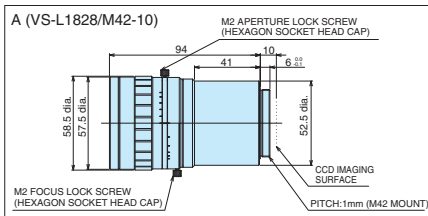

Lenses for FZ-series small cameras

FZ-LES Series

- Product lineup includes two types of small camera lenses, a pen type with a 12-mm diameter and a flat type with a 17-mm thickness.



Ordering Information

Recommended cameras	Model	Focal length (mm)	Aperture (F No.)
FZ-SF□ FZ-SP□	FZ-LES3	3	2.0 to 16
	FZ-LES6	6	2.0 to 16
	FZ-LES16	16	3.4 to 16
	FZ-LES30	30	3.4 to 16

Dimensions (Unit: mm)

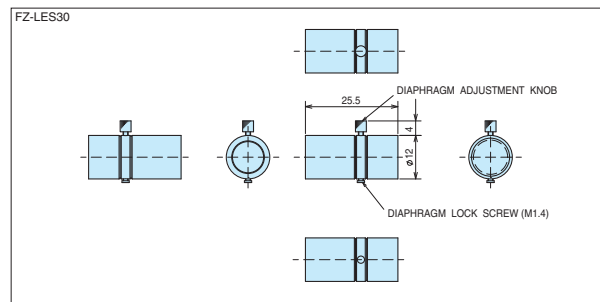
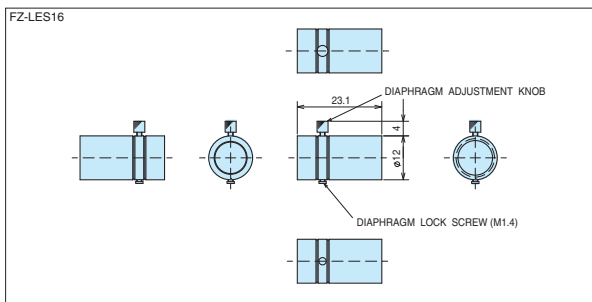
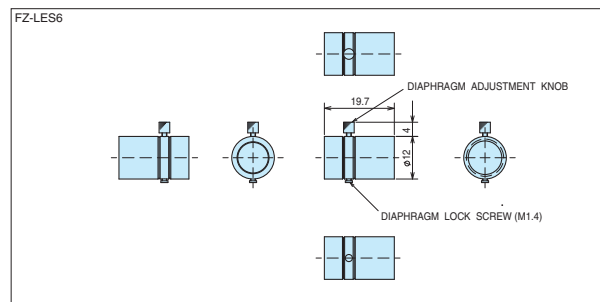
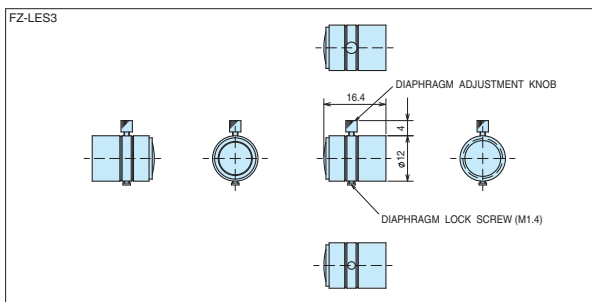

Non-telecentric Macro Lens VS-MC Series

- Lineup of 4 models with magnifications ranging from 0.1 to 1.0 and WD ranging from 82.4 to 325.5 mm.
- 16-mm-dia. simple mechanism with high resistance to vibration.



Ordering Information

Recommend camera	Model	Dimension	Magnification	Field of vision *1 (V × H) mm	Dimension Effective FNO	O/I (mm)	WD (mm)	Depth of field *2 (mm)	Resolution *3 (μm)	TV distortion
FZ-S□	3Z4S-LE VS-MC01-330	A	0.1	66.0 × 88.0	4.43	364.5	325.5	35.4	30.5	0.01% max.
FZ-SH□	3Z4S-LE VS-MC03-180	B	0.3	22.0 × 29.3	5.29	248.5	184.8	4.7	11.6	0.00% max.
FZ-S□2M	3Z4S-LE VS-MC05-130	C	0.5	13.2 × 17.6	6.10	198.8	126.3	2.0	8.2	0.00% max.
FZ-S□5M2	3Z4S-LE VS-MC1-80	D	1.0	6.6 × 8.8	8.14	176.8	82.4	0.7	5.5	0.00% max.

*1 Calculated using the size of an image element (2/3 inch = 6.6 × 8.8 mm).

*2 Calculated using a permissible circle of confusion diameter of 0.04 mm.

*3 Calculated using a wavelength of 550 nm.

Dimensions (Unit: mm)

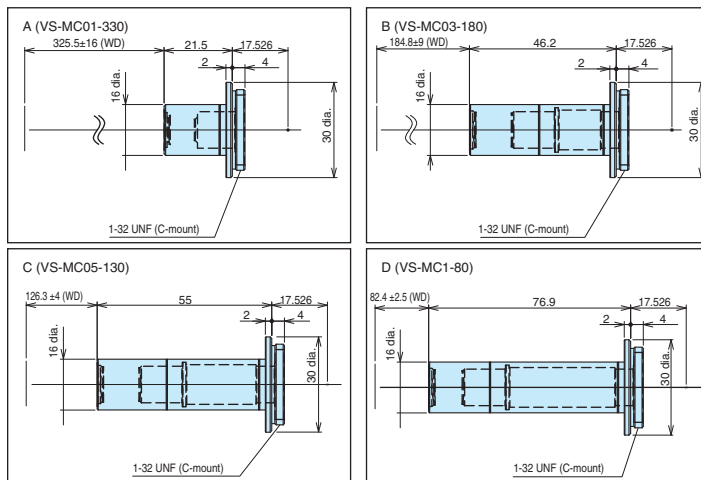

Lens Option

Ordering Information

Polarizing Filter

Model	Size
3Z4S-LE SV-PL255	M25.5 P0.5
3Z4S-LE SV-PL270	M27.0 P0.5
3Z4S-LE SV-PL305	M30.5 P0.5



Extension Tubes

Lenses	Model	Contents
For C-mount Lens	3Z4S-LE SV-EXR	7-piece set *1,*2 (40 mm, 20 mm, 10 mm, 5 mm, 2mm, 1 mm, 0.5 mm) Maximum outer diameter: 30 mm dia.
For M42-mount Cameras	3Z4S-LE VS-EXR/M42	Set of 5 tubes *1 (20 mm, 10 mm, 8 mm, 2 mm, and 1 mm) Maximum outer diameter: 47.5 mm dia.
For Small Digital CCD Cameras	FZ-LESR	Set of 3 tubes (15 mm, 10 mm, 5 mm) Maximum outer diameter: 12 mm dia.



*1 Do not use the 0.5-mm, 1.0-mm, and 2.0-mm Extension Tubes attached to each other. Since these Extension Tubes are placed over the threaded section of the Lens or other Extension Tube, the connection may loosen when more than one 0.5-mm, 1.0-mm or 2.0-mm Extension Tube are used together.

Reinforcement is required to protect against vibration when Extension Tubes exceeding 30 mm are used. When using the Extension Tube, check it on the actual device before using it.

*2 These Extension Tubes are also available individually. Order using the following model number, replacing the box with the desired length: 3Z4S-LE SV-EXR□. (0.5, 1, 2, 5, 10, 15, 20, 25, 30, 40, 50 mm)

Extension Tubes for Small Digital CCD Cameras

Model	Contents
FZ-LESR	Set of 3 tubes (15 mm, 10 mm, 5 mm) Maximum outer diameter: 12 mm dia.

Rear Converter Lens

Model
3Z4S-LE SV-1.5X *1
3Z4S-LE SV-2.0X *2

*1 In the following lenses, it is necessary to use it together with the extension tubes of 5 mm or more.

SV-0614H, SV-0814H, SV-1214H, SV-2514H, SV-0614V, SV-0813V

*2 In the following lenses, it is necessary to use it together with the extension tubes of 5 mm or more.

SV-0614H, SV-0814H, SV-1214H, SV-2514H, SV-0813V

● Configuration

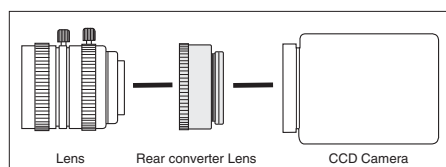

LED Characteristics

Safety of LED

The LEDs that are used in the Light are classified as follows according to IEC 62471.

Series	Shape	Model	Color	Safety of LED	Indication
FLV Series	Direct Ring Light	FLV-DR□	White, Blue	Risk Group 2	B
	Direct Ring Light	FLV-DR□	Red, Ultraviolet	Risk Group 1	D
	Direct Ring Light	FLV-DR□IR	Infrared	Risk Group 1	C
	Low Angle Ring Light	FLV-DL□	White, Red, Blue	Risk Group 1	D
	Bar Light	FLV-BR□	White, Blue	Risk Group 2	B
	Bar Light	FLV-BR□	Red, Ultraviolet	Risk Group 1	D
	Bar Light	FLV-BR□IR	Infrared	Risk Group 1	C
	Coaxial Light	FLV-CL□	White, Red, Blue, Ultraviolet	Risk Group 1	D
	Coaxial Light	FLV-CL□IR	Infrared	Risk Group 1	C
	Shadowless Light	FLV-FS□	White, Red, Blue	Risk Group 1	D
	Shadowless Light	FLV-FR□	White, Red, Blue	Risk Group 1	D
	Shadowless Light	FLV-FP□	White, Red, Blue	Risk Group 1	D
	Shadowless Light	FLV-FQ□	White, Red, Blue	Risk Group 1	D
	Direct Back Light	FLV-DB□	White, Red, Blue	Risk Group 1	D
	Edge Type Light	FLV-FB□	White, Red, Blue	Risk Group 1	D
	Edge Type Coaxial Light	FLV-FX□	White, Red, Blue	Risk Group 1	D
	Dome Light	FLV-DD□	White, Red, Blue	Risk Group 1	D
	High-power Spot Light	FLV-EP08□	White, Red	Risk Group 1	D
	Spot Light	FLV-EP50□	White, Red, Blue	Risk Group 1	D
	Line Light	FLV-LN□W	White	Risk Group 3	A
Line Light	FLV-LN□R	Red	Risk Group 1	D	
Line Light	FLV-LN□B	Blue	Risk Group 2	B	
FL Series	Direct Ring Light	FL-DR□	White	Risk Group 2	B
	Bar Light	FL-BR□	White	Risk Group 2	B

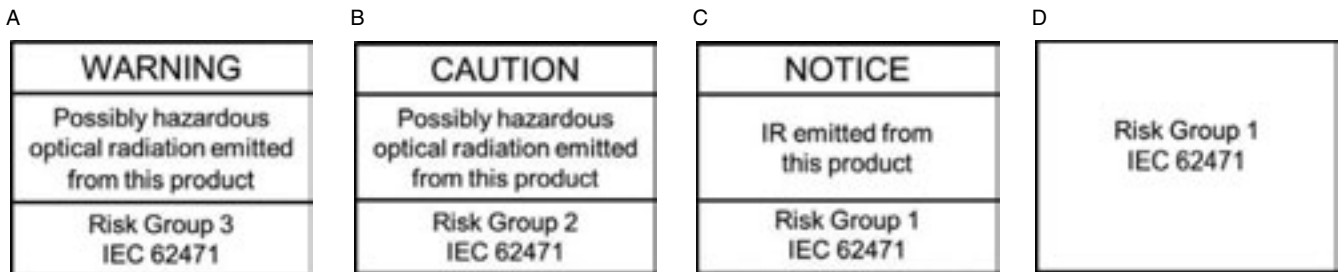

Typical LED Spectral Distributions

Typical spectral distributions and peak wavelengths of each LED color are shown in the diagrams below.

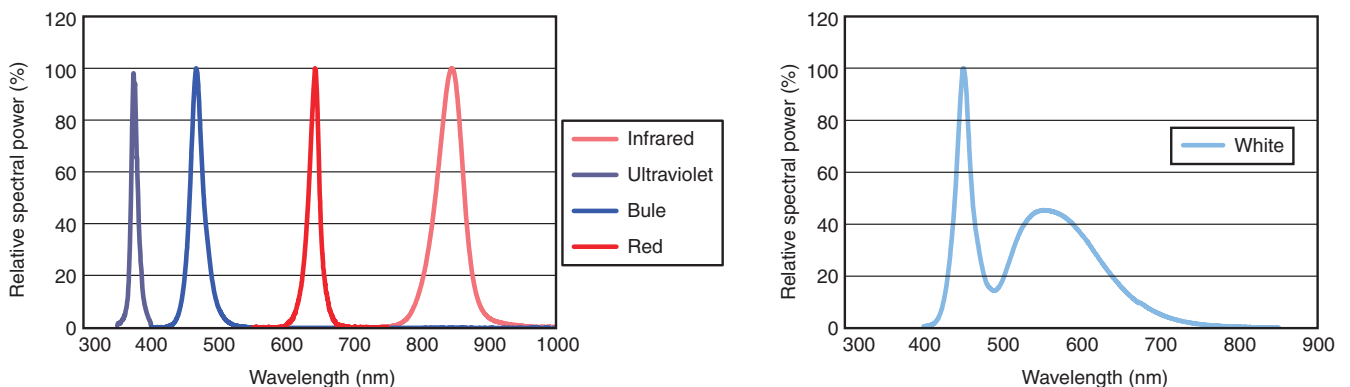

Terms and Conditions Agreement

Read and understand this catalog.

Please read and understand this catalog before purchasing the products. Please consult your OMRON representative if you have any questions or comments.

Warranties.

(a) Exclusive Warranty. Omron's exclusive warranty is that the Products will be free from defects in materials and workmanship for a period of twelve months from the date of sale by Omron (or such other period expressed in writing by Omron). Omron disclaims all other warranties, express or implied.

(b) Limitations. OMRON MAKES NO WARRANTY OR REPRESENTATION, EXPRESS OR IMPLIED, ABOUT NON-INFRINGEMENT, MERCHANTABILITY OR FITNESS FOR A PARTICULAR PURPOSE OF THE PRODUCTS. BUYER ACKNOWLEDGES THAT IT ALONE HAS DETERMINED THAT THE PRODUCTS WILL SUITABLY MEET THE REQUIREMENTS OF THEIR INTENDED USE.

Omron further disclaims all warranties and responsibility of any type for claims or expenses based on infringement by the Products or otherwise of any intellectual property right. (c) Buyer Remedy. Omron's sole obligation hereunder shall be, at Omron's election, to (i) replace (in the form originally shipped with Buyer responsible for labor charges for removal or replacement thereof) the non-complying Product, (ii) repair the non-complying Product, or (iii) repay or credit Buyer an amount equal to the purchase price of the non-complying Product; provided that in no event shall Omron be responsible for warranty, repair, indemnity or any other claims or expenses regarding the Products unless Omron's analysis confirms that the Products were properly handled, stored, installed and maintained and not subject to contamination, abuse, misuse or inappropriate modification. Return of any Products by Buyer must be approved in writing by Omron before shipment. Omron Companies shall not be liable for the suitability or unsuitability or the results from the use of Products in combination with any electrical or electronic components, circuits, system assemblies or any other materials or substances or environments. Any advice, recommendations or information given orally or in writing, are not to be construed as an amendment or addition to the above warranty.

See <http://www.omron.com/global/> or contact your Omron representative for published information.

Limitation on Liability; Etc.

OMRON COMPANIES SHALL NOT BE LIABLE FOR SPECIAL, INDIRECT, INCIDENTAL, OR CONSEQUENTIAL DAMAGES, LOSS OF PROFITS OR PRODUCTION OR COMMERCIAL LOSS IN ANY WAY CONNECTED WITH THE PRODUCTS, WHETHER SUCH CLAIM IS BASED IN CONTRACT, WARRANTY, NEGLIGENCE OR STRICT LIABILITY.

Further, in no event shall liability of Omron Companies exceed the individual price of the Product on which liability is asserted.

Suitability of Use.

Omron Companies shall not be responsible for conformity with any standards, codes or regulations which apply to the combination of the Product in the Buyer's application or use of the Product. At Buyer's request, Omron will provide applicable third party certification documents identifying ratings and limitations of use which apply to the Product. This information by itself is not sufficient for a complete determination of the suitability of the Product in combination with the end product, machine, system, or other application or use. Buyer shall be solely responsible for determining appropriateness of the particular Product with respect to Buyer's application, product or system. Buyer shall take application responsibility in all cases.

NEVER USE THE PRODUCT FOR AN APPLICATION INVOLVING SERIOUS RISK TO LIFE OR PROPERTY OR IN LARGE QUANTITIES WITHOUT ENSURING THAT THE SYSTEM AS A WHOLE HAS BEEN DESIGNED TO ADDRESS THE RISKS, AND THAT THE OMRON PRODUCT(S) IS PROPERLY RATED AND INSTALLED FOR THE INTENDED USE WITHIN THE OVERALL EQUIPMENT OR SYSTEM.

Programmable Products.

Omron Companies shall not be responsible for the user's programming of a programmable Product, or any consequence thereof.

Performance Data.

Data presented in Omron Company websites, catalogs and other materials is provided as a guide for the user in determining suitability and does not constitute a warranty. It may represent the result of Omron's test conditions, and the user must correlate it to actual application requirements. Actual performance is subject to the Omron's Warranty and Limitations of Liability.

Change in Specifications.

Product specifications and accessories may be changed at any time based on improvements and other reasons. It is our practice to change part numbers when published ratings or features are changed, or when significant construction changes are made. However, some specifications of the Product may be changed without any notice. When in doubt, special part numbers may be assigned to fix or establish key specifications for your application. Please consult with your Omron's representative at any time to confirm actual specifications of purchased Product.

Errors and Omissions.

Information presented by Omron Companies has been checked and is believed to be accurate; however, no responsibility is assumed for clerical, typographical or proofreading errors or omissions.

Would you like to know more?

Omron Europe B.V.

 +31 (0) 23 568 13 00

 industrial.omron.eu

Stay in touch

 twitter.com/omroneurope

 youtube.com/user/omroneurope

 linkedin.com/company/omron

Austria

Tel: +43 (0) 2236 377 800
industrial.omron.at

Belgium

Tel: +32 (0) 2 466 24 80
industrial.omron.be

Czech Republic

Tel: +420 234 602 602
industrial.omron.cz

Denmark

Tel: +45 43 44 00 11
industrial.omron.dk

Finland

Tel: +358 (0) 207 464 200
industrial.omron.fi

France

Tel: +33 (0) 1 56 63 70 00
industrial.omron.fr

Germany

Tel: +49 (0) 2173 680 00
industrial.omron.de

Hungary

Tel: +36 1 399 30 50
industrial.omron.hu

Italy

Tel: +39 02 326 81
industrial.omron.it

Netherlands

Tel: +31 (0) 23 568 11 00
industrial.omron.nl

Norway

Tel: +47 (0) 22 65 75 00
industrial.omron.no

Poland

Tel: +48 22 458 66 66
industrial.omron.pl

Portugal

Tel: +351 21 942 94 00
industrial.omron.pt

Russia

Tel: +7 495 648 94 50
industrial.omron.ru

South Africa

Tel: +27 (0)11 579 2600
industrial.omron.co.za

Spain

Tel: +34 902 100 221
industrial.omron.es

Sweden

Tel: +46 (0) 8 632 35 00
industrial.omron.se

Switzerland

Tel: +41 (0) 41 748 13 13
industrial.omron.ch

Turkey

Tel: +90 212 467 30 00
industrial.omron.com.tr

United Kingdom

Tel: +44 (0) 1908 258 258
industrial.omron.co.uk

More Omron representatives

industrial.omron.eu