

Profile Measuring System

Z500

High-Precision Sensor that Measures and Displays an Object's Profile.



Z500

Features

OMRON's original line beam method provides a complete solution to profile measurement problems.

Conventional non-contact measurement of the profile of an object commonly uses a displacement sensor to measure the height of the object, by moving the object or the sensor.

However, this system has several disadvantages, such as lower measurement accuracy resulting from object or sensor movement as well as high system construction cost.

By utilizing a unique wide beam method and 2-dimensional CCD, OMRON's Z500 eliminates these problems.

Through its capability of measuring a diversely-shaped objects in a stable manner, the Z500 can meet a variety of application needs.

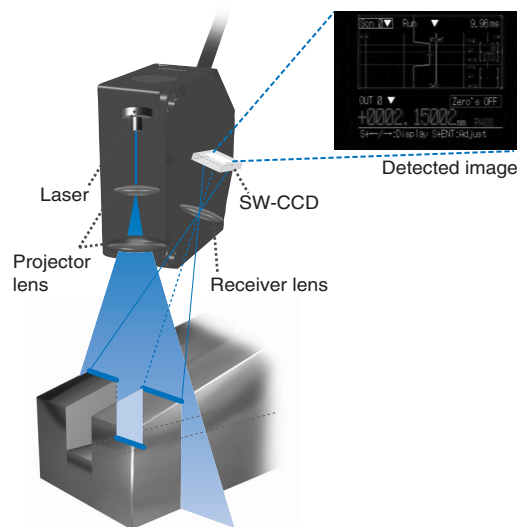

Principle of line beam method

A wide beam is applied to the object to be measured. A 2-dimensional CCD receives the reflected light to measure the 2-dimensional profile of the object.

Application

Measurement of connector pin configuration

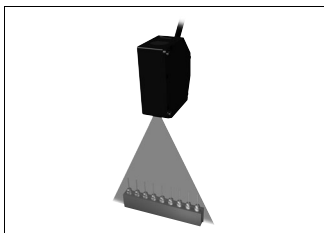

Height measurement for cream-soldered joint on PCB

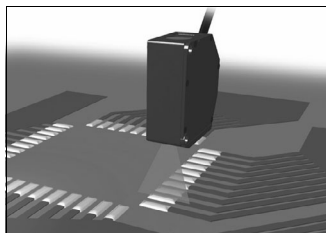

Rivet height measurement

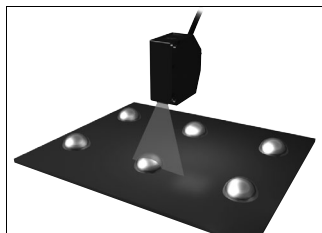

Door gap measurement

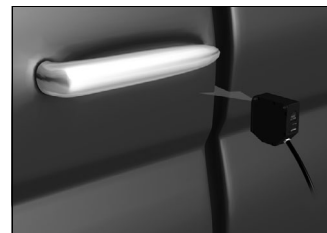

Features

Measures the shape of object instantly.

A complete solution to the disadvantages of conventional measurement systems.

Measurement by displacement sensor

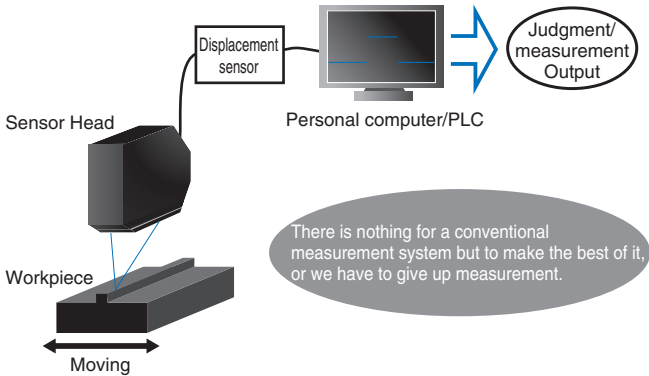

Problems to be resolved

- Object or sensor needs to be moved.
- Personal computer or other device is required for measurement data processing.

Increased system construction cost
Measurement accuracy deterioration caused by movement of object or sensor and data processing.
Measurement takes a long time.



Measurement by Z500 model

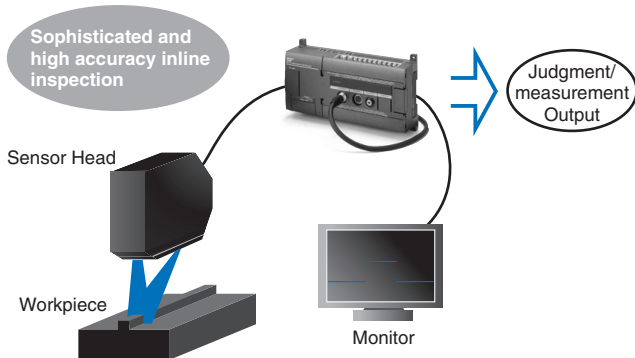

Enjoy the following advantages from Z500 !

- Moving the object or sensor is no longer necessary.
- Various data processing and calculation functions are performed automatically.

Lower system construction cost
Higher measurement accuracy
Shorter measurement time

Accurate and stable measurement.

OMRON's original 2-dimensional SW-CCD and multiple light intensity control system enable stable measurement of objects with round shape and other surface conditions.

A variety of measurement items.

Various measurement items, such as level difference, width, and edge position, can be selected depending on the specific application.

Permitting simultaneous measurement of up to 8 items, the Z500 is applicable to various measurement purposes.

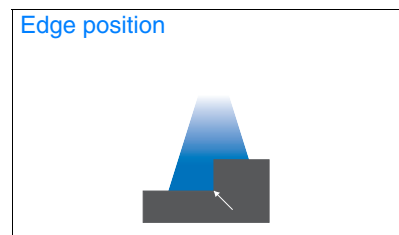
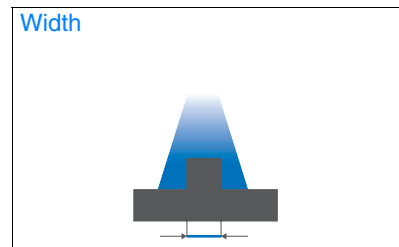
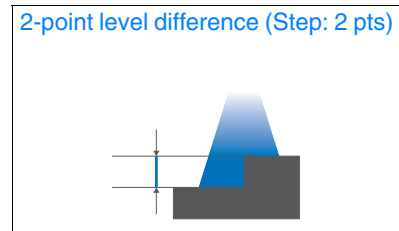

Four types of monitor screens

Measurement data can be displayed on 4 types of monitor screens.

These screens enable analysis and evaluation of measurement data from various viewpoints.

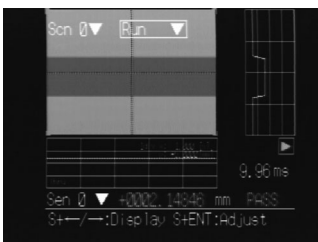

Profile monitor

Time-series change of profile (data on cross section height) can be checked on a 3D gray scale image.

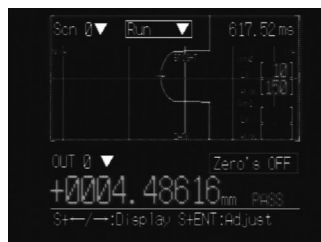
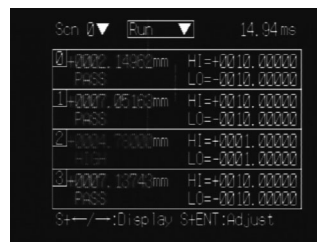

Image monitor

Both measurement data and profile image can be checked at the same time.



Digital monitor

Two or more measurement data can be checked at the same time.



Trend monitor

Time-series change of measurement data can be checked.

System configuration

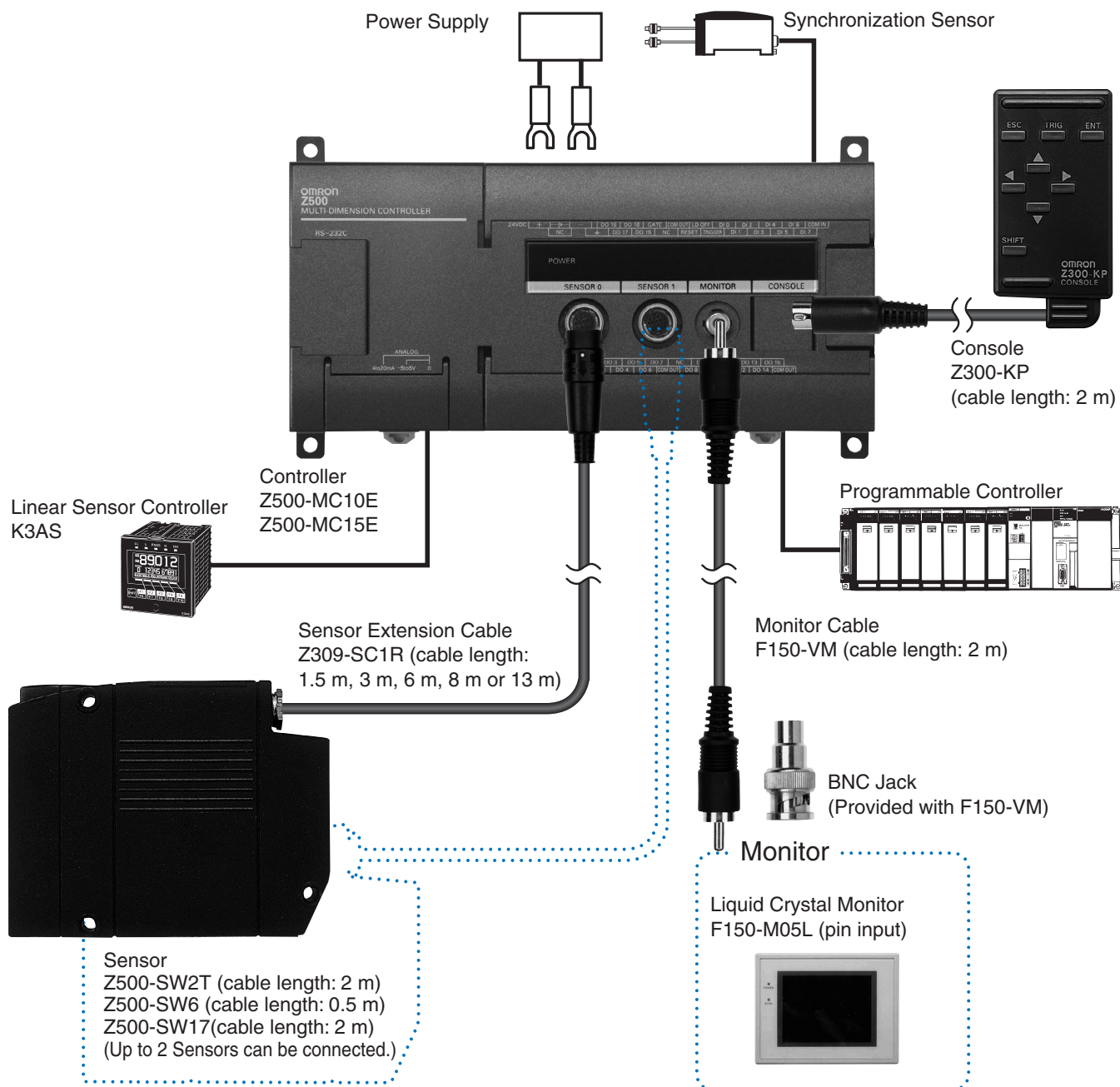

Z500

Ordering Information

Name	Item	Model	Remarks
Sensor		Z500-SW2T	Cable length: 2 m
		Z500-SW6	Cable length: 0.5 m
		Z500-SW17	Cable length: 2 m
Controller		Z500-MC10E	NPN input/output
		Z500-MC15E	PNP input/output
Console		Z300-KP	—
Liquid Crystal Monitor		F150-M05L	—
Sensor Extension Cable		Z309-SC1R (See note)	Cable length: 1.5 m, 3 m, 6 m, 8 m or 13 m
Monitor Cable		F150-VM	Cable length: 2 m

Note: Specify the required cable length when ordering.

Rating/Performance

Sensor Z500-SW2T/-SW6/-SW17

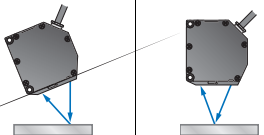
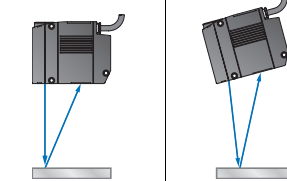
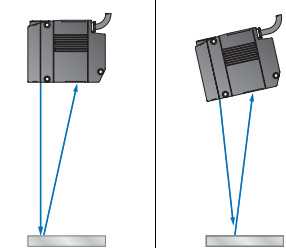
Model		Z500-SW2T		Z500-SW6		Z500-SW17	
		Diffuse reflection	Mirror reflection	Diffuse reflection	Mirror reflection	Diffuse reflection	Mirror reflection
Item	Measurement mode						
	Distance to measurement center	5.2 mm	20 mm (with beam cover attached: 16 mm)	50 mm	44 mm	100 mm	94 mm
Measurement range		±0.8 mm		±5 mm	±4 mm	±20 mm	±16 mm
Light source		Visible-light semiconductor laser (See note 10) (Wavelength 650 nm, 1 mW max., Class 2)		Visible-light semiconductor laser (Wavelength 658 nm, 15 mW max., Class 3B)			
Beam dimensions (See note 1)		Reference distance: 20 μm × 4 mm TYP. (Measurement region: 2 mm)		Reference distance: 30 μm × 24 mm TYP. (Measurement region: 6 mm)		Reference distance: 60 μm × 45 mm TYP. (Measurement region: 17 mm)	
Linearity		±0.1 %F.S. (See note 3)	±0.1 %F.S. (See note 2)	±0.1 %F.S. (See note 4)			
Resolution		0.25 μm (See notes 5 and 6)		0.3 μm (See notes 7 and 8)		1 μm (See notes 7 and 8)	
Sampling cycle		9.94 ms					
LED indicators (LASER indicator)		Lit while laser is ON.					
Temperature characteristic (See note 9)		0.01 %F.S./°C					
Environment resistance	Degree of protection	IEC IP64		IEC IP66			
	Ambient operating illumination	Illumination at light-receiving surface: 3,000 lx max., incandescent light					
	Ambient temperature	Operating: 0 to +50 °C, Storage: -15 to +60 °C (with no icing or condensation)					
	Ambient humidity	Operating and storage: 35 to 85 % RH (with no condensation)					
	Vibration resistance	10 to 150 Hz (single amplitude: 0.35 mm) for 80 min. each in X, Y, and Z directions					
Materials		Unit: Die-cast aluminum Cable sheathing: Heat-resistant chlorinated vinyl Connector: zinc alloy and brass					
Cable length		2 m		0.5 m		2 m	
Minimum bending radius		68 mm					
Weight (including packaging)		Approx. 600 g (Unit: Approx. 350 g)		Approx. 700 g (Unit: Approx. 600 g)		Approx. 800 g (Unit: Approx. 600 g)	
Accessories		3 ferrite cores, laser warning labels (English)					

- Note: 1. Defined at 1/e² (13.5%) of the density at the light center. Light may, however, be present outside this range and if the reflection factor of the light around the workpiece is high compared to the workpiece, measurement may be affected.
2. Error with respect to the theoretical line representing the displacement output for measurement of OMRON standard quartz glass. The linearity varies with the type of workpiece.
3. Error with respect to the theoretical line representing the displacement output for measurement of OMRON standard SUS blocks. The linearity varies with the type of workpiece.
4. Error with respect to the theoretical line representing the displacement output for measurement of OMRON standard white alumina ceramics. The linearity varies with the type of workpiece.

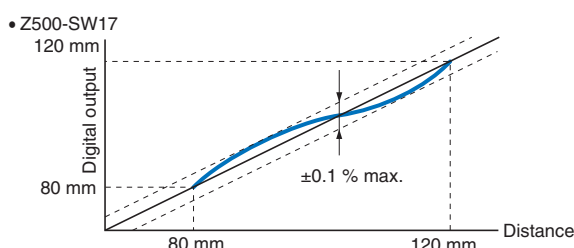

5. Displacement conversion value for peak-to-peak of displacement output. These figures are for measurement of OMRON standard quartz glass (mirror reflection).

-
- tion mode) or OMRON standard SUS blocks (diffuse reflection mode) at the measurement center. In strong magnetic fields, it may not be possible to maintain resolution performance characteristics.
6. These figures are for when the Sensor is connected to the Z500-MC10E/MC15E, the average number of measurements is 16. Measurement data are sent to PC via RS-232C cable for calculation of their average values.
 7. Displacement conversion value for peak-to-peak of displacement output (for measurement of OMRON standard white alumina ceramic at the measurement center). In strong magnetic fields, it may not be possible to maintain resolution performance characteristics.
 8. With the Z500-MC10E/MC15E, at an average number of measurements of 64. Measurement data are sent to PC via RS-232C cable for calculation of their average values.
 9. Value for measurement with the space between the Sensor and the workpiece (white alumina ceramic) secured with an aluminum jig.
 10. Higher power laser type (Class 3B) is also available. For further information, please contact us.

Controller Z500-MC10E/MC15E

Item	Model Input/Output Type	Z500-MC10E	Z500-MC15E
		NPN	PNP
Performance specifications	Number of Sensors that can be mounted	2	
	Number of scenes	16	
	Light intensity tracking function	Automatic (The light intensity tracking range can be specified)/Fixed (Select from 31 stages)/Multiple (The light intensity range can be specified)	
	Measurement item	Select from the following 8 types: Height, Step: 2 pts, Step: 3 pts, Edge position, With, Edge center, Peak/Bottom, Define	
	Region specification	Region specification of line beam and displacement direction is possible.	
	Number of data to be stored	2048 points max.	
	Trigger function	Free/External 1/External 2/Auto	
	Results output	<ul style="list-style-type: none"> • Judgment output <ul style="list-style-type: none"> ↳ RS-232C output ↳ Terminal block output • Measurement value output (measurement value) <ul style="list-style-type: none"> ↳ RS-232C output ↳ Analog output 	
	Terminal block	11 input points: $\overline{\text{TRIGGER}}$, $\overline{\text{LD-OFF}}$, $\overline{\text{RESET}}$, $\overline{\text{D10}}$ to $\overline{\text{D17}}$ 21 output points: $\overline{\text{DO0}}$ to $\overline{\text{DO19}}$, $\overline{\text{GATE}}$	
	Monitor interface	1CH (for pin jack or overscan monitor)	
Analog output resolution	The full scale for output can be divided into a maximum of 40,000 gradations. Resolution (See note): 0.25 mV (± 5 V), 0.4 μ A (4 to 20 mA)		
General specifications	Power supply voltage	21.6 to 26.4 VDC	
	Current consumption	1 A max. (with 2 Sensors connected)	
	Insulation resistance	20 M Ω min. between all DC external terminals and GR terminal (100 VDC megger) (with internal surge absorber removed)	
	Dielectric strength	1000 VAC, 50/60 Hz between all DC external terminals and GR terminal (with internal surge absorber removed)	
	Leakage current	10 mA max.	
	Noise resistance	1500 Vp-p; pulse width: 0.1 μ s/1 μ s, Rising edge: 1-ns pulse	
	Vibration resistance	10 to 150 Hz (double amplitude: 0.1 mm) for 8 min. each in X, Y, and Z directions	
	Shock resistance	200 m/s ² , 3 times each in 6 directions	
	Ambient temperature	Operating: 0 to +50 °C, Storage: -15 to +60 °C (with no icing or condensation)	
	Ambient humidity	Operating and storage: 35 to 85 %RH (with no condensation)	
	Ambient environment	No corrosive gases	
	Ground	Ground the Z500's ground terminal to less than 100 Ω	
	Degree of protection	IEC IP20 (in-panel)	
	Material	Unit: ABS	
	Weight (including packaging)	Approx. 1300 g (Unit: Approx. 700 g)	
Accessories	2 manuals, 1 resistor (250 Ω , 1/2 W)		

Note: For measurement at an average number of times of 64 with an OMRON K3AS Linear Sensor Controller connected.

Monitor

Item	Monitor	Liquid Crystal Monitor
	Model	F150-M05L
Panel size	5.5 inches	
Panel type	TFT color liquid crystal	
Resolution	320 × 240 dots	
Input signal	NTSC composite video (1.0 V/75 Ω)	
Power supply voltage	20.4 to 26.4 VDC	
Current consumption	Approx. 700 mA	
Ambient temperature	Operating: 0 to +50 °C, Storage: -25 to +65 °C (with no icing or condensation)	
Ambient humidity	Operating and storage: 35 to 85 %RH (with no condensation)	
Weight (including packaging)	Approx. 870 g (Unit: Approx. 610 g)	
Accessories	Operation manual, 4 mounting brackets	

Laser Safety

The Z500-SW2T Sensor Head is a Class 2 Laser Product according to EN60825-1 (IEC60825-1) and Class II Laser Product according to FDA (21 CFR1040.10) (see note). The Z500-SW6 and Z500-SW17 Sensor Heads are Class 3B and Class IIIB Laser Products, respectively. The Z500 Series is meant to be built into final system equipment. Pay special attention to the following precautions for the safe use of the product:

Note: Europe: Class 2 and Class 3B of EN60825-1: 1994 = IEC60825-1: 1993
 U.S.A.: Class II and Class IIIB of FDA (21 CFR1040.10)

	Z500-SW2T	Z500-SW6/Z500-SW17
Wavelength	650 nm	658 nm
Maximum pulse duration	10 ms	17.5 ms
Cycle	0.5 to 10 ms	0.5 to 25 ms
Peak power	1 mW max.	15 mW max.
Class	2	3B

- (1) Use this product as specified in the operation manual. Otherwise, you may be exposed to hazardous laser radiation.
- (2) The Z500 series radiates laser beams in the visible light range. Do not expose your eyes directly to the laser radiation. Ensure that the laser beam path is terminated during use. If a mirror or shiny surface is positioned in the laser beam path, ensure that the reflected beam path is also terminated. If the Unit must be used without terminating the laser beam path, position the laser beam path so that it is not at eye level.
- (3) To avoid exposure to hazardous laser radiation, do not displace nor remove the protective housing during operation, maintenance, and any other servicing.
- (4) The user should return the product to OMRON for all repair and servicing.
- (5) As for countries other than those of Europe and the U.S.A., observe the regulations and standards specified by each country.

Dimensions (Unit: mm)

Sensor

Z500-SW2T

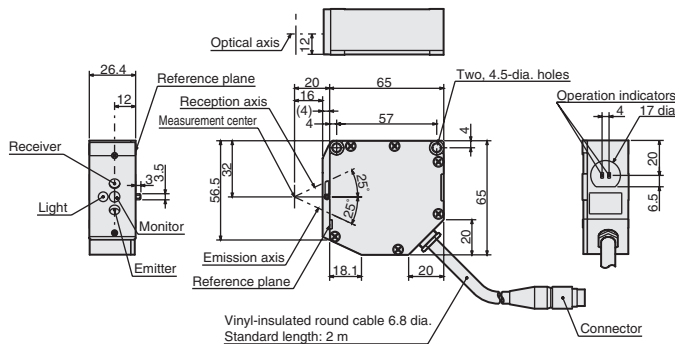

Z500-SW6

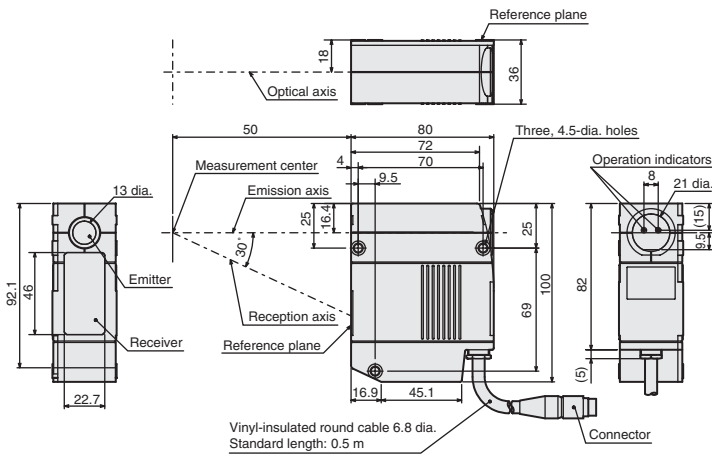

Sensor
Z500-SW17

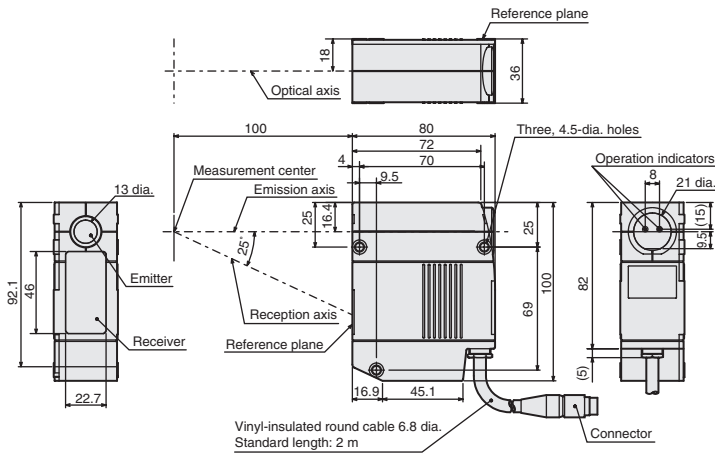

Liquid Crystal Monitor
F150-M05L

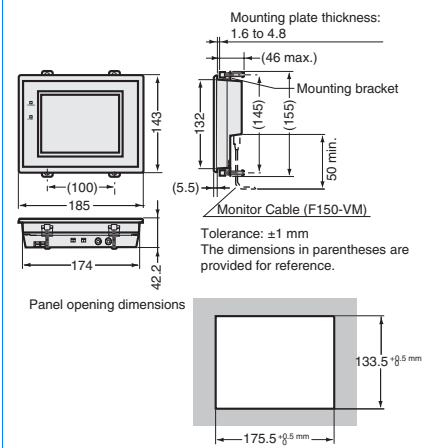

Controller
Z500-MC10E/MC15E

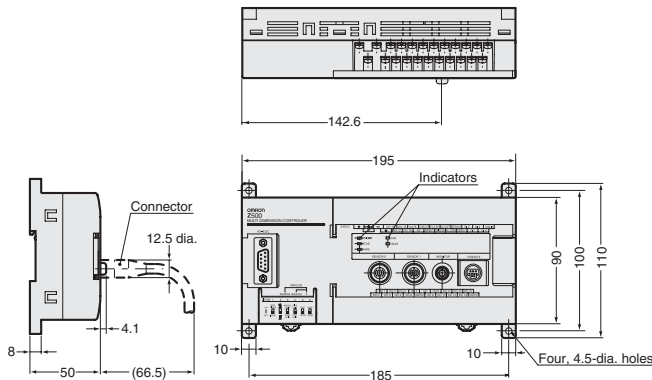

Console
Z300-KP

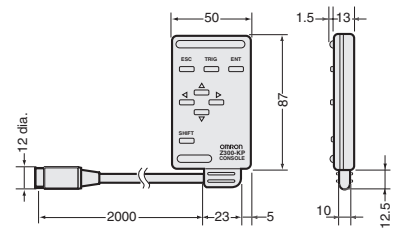

ALL DIMENSIONS SHOWN ARE IN MILLIMETERS.
To convert millimeters into inches, multiply by 0.03937. To convert grams into ounces, multiply by 0.03527.