

CIMR-A

# A1000

**High performance Vector Control**

- Current vector control, with or without PG
- High starting torque (200% / 0.3 Hz, spd range 1:200 OLV), (200% at 0 r/min, spd range 1:1500 CLV)
- Double rating ND 120%/1min and HD 150%/1 min
- IM&PM motor control
- Advanced Auto-Tuning for IM & PM Motors
- Open Loop Control of PM Motors
- Low-noise Low carrier technology
- 10 years lifetime design
- Screw-less terminals
- Control Terminals with memory backup
- 24 VDC control board power supply option
- Fieldbus communications: Modbus, Profibus, CanOpen, DeviceNet, ML-II
- Safety embedded: EN954-1 safety cat. 3, stop category 0, IEC EN 61508 SIL 2 and EN61800-5-1 with EDM
- CE, UL, cUL and TUV

**Ratings**

- 200 V Class three-phase 0.4 to 110 kW
- 400 V Class three-phase 0.4 to 315 kW



**System configuration**

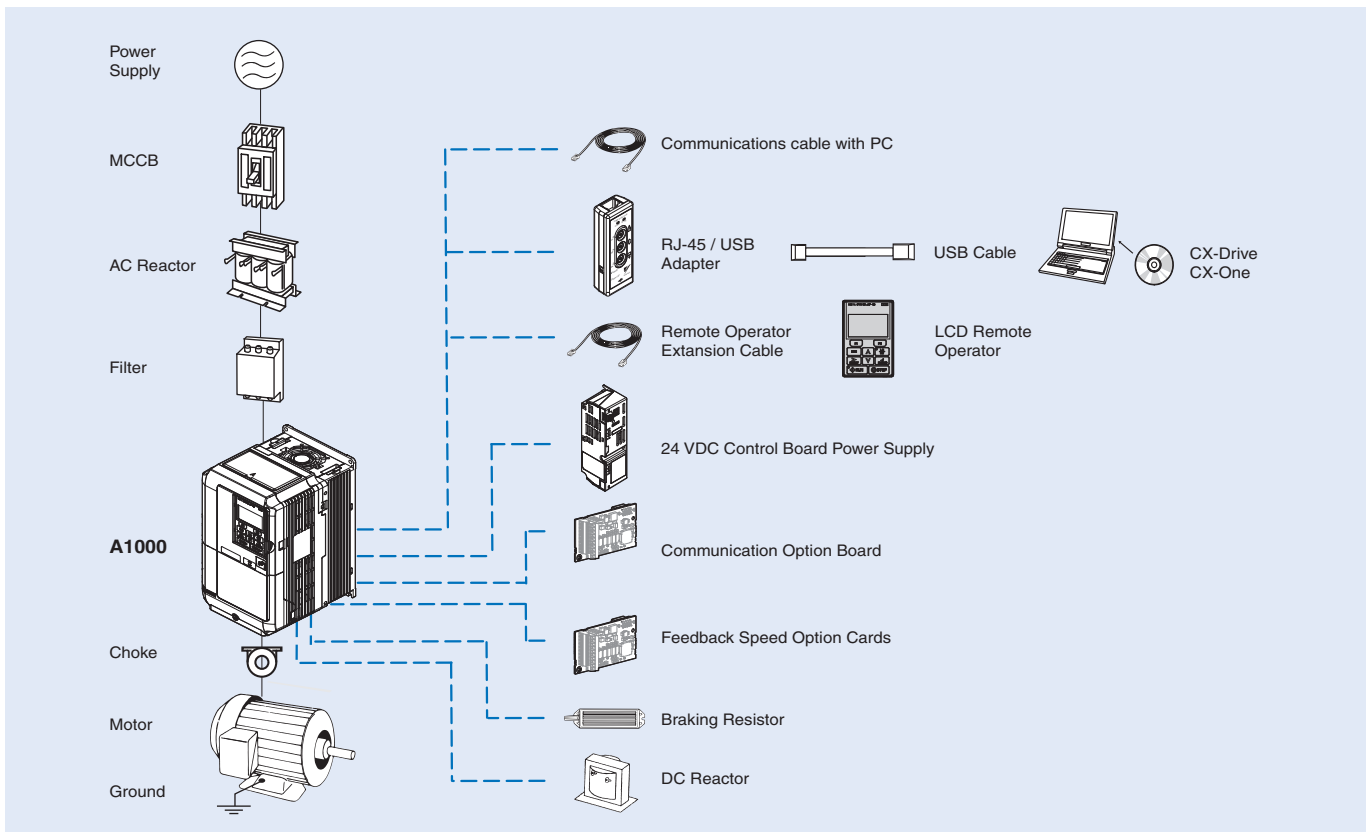

Specifications

Type designation

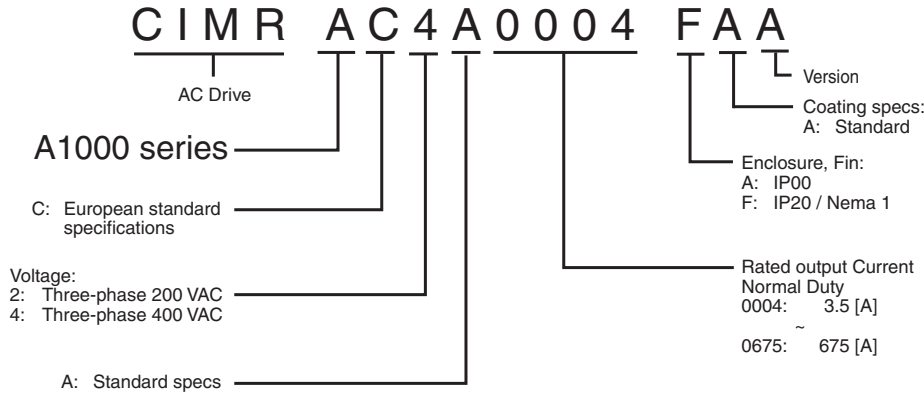

200 V class

Three-phase: CIMR-A□2A		0004	0006	0010	0012	0021	0030	0040	0056	0069	0081	0110	0138	0169	0211	0250	0312	0360	0415	
Motor kW <sup>1</sup>	For HD setting	0.40	0.75	1.5	2.2	4.0	5.5	7.5	11	15	18.5	22	30	37	45	55	75	90	110	
	For ND setting	0.75	1.1	2.2	3.0	5.5	7.5	11	15	18.5	22	30	37	45	55	75	90	110	110	
Output characteristics	Inverter capacity kVA at HD <sup>2</sup>	1.2	1.9	3	4.2	6.7	9.5	12.6	17.9	23	29	32	44	55	69	82	108	132	158	
	Inverter capacity kVA at ND <sup>2</sup>	1.3	2.3	3.7	4.6	8	11.4	15.2	21	26	31	42	53	64	80	95	119	137	158	
	Rated output current (A) at HD	3.2 <sup>4</sup>	5 <sup>4</sup>	8 <sup>4</sup>	11 <sup>4</sup>	17.5 <sup>4</sup>	25 <sup>4</sup>	33 <sup>4</sup>	47 <sup>4</sup>	60 <sup>4</sup>	75 <sup>4</sup>	85 <sup>4</sup>	115 <sup>4</sup>	145 <sup>5</sup>	180 <sup>5</sup>	215 <sup>5</sup>	283 <sup>5</sup>	346 <sup>5</sup>	415 <sup>3</sup>	
	Rated output current (A) at ND <sup>3</sup>	3.5	6	9.6	12	21	30	40	56	69	81	110	138	169	211	250	312	360	415	
	Max. output voltage	Proportional to input voltage: 0..240 V																		
	Max. output frequency	400 Hz																		
Power supply	Rated input voltage and frequency	3-phase 200..240 V 50/60 Hz																		
	Allowable voltage fluctuation	-15%..+10%																		
	Allowable frequency fluctuation	+5%																		
	Input Current (A) at HD <sup>6</sup>	2.9	5.8	7.5	11	18.9	28	37	52	68	80	82	111	136	164	200	271	324	394	
	Input Current (A) at ND <sup>6</sup>	3.9	7.3	10.8	13.9	24	37	52	68	80	96	111	136	164	200	271	324	394	471	

- Based on a standard 4-pole motor for maximum applicable motor output:
- Rated Motor Capacity is calculated with a rated output voltage of 220 V:
- Carrier frequency is set to 2kHz. Current derating is required in order to raise the carrier frequency:
- Carrier frequency can be increased up to 8 kHz while keeping this current rating. Higher carrier frequency settings require derating:
- Carrier frequency can be increased up to 5 kHz while keeping this current rating. Higher carrier frequency settings require derating:
- Assumes operation at rated output current. Input current rating varies depending on the power supply transformer, input reactor, Wiring conditions, and power supply impedance:

400 V class

Three-phase: CIMR-A□4A		0002	0004	0005	0007	0009	0011	0018	0023	0031	0038	0044	0058	
Motor kW <sup>1</sup>	For HD setting	0.4	0.75	1.5	2.2	3.0	4.0	5.5	7.5	11	15	18.5	22	
	For ND setting	0.75	1.5	2.2	3.0	4.0	5.5	7.5	11	15	18.5	22	30	
Output characteristics	Inverter capacity kVA at HD <sup>2</sup>	1.4	2.6	3.7	4.2	5.5	7	11.3	13.7	18.3	24	30	34	
	Inverter capacity kVA at ND <sup>2</sup>	1.6	3.1	4.1	5.3	6.7	8.5	13.3	17.5	24	29	34	44	
	Rated output current (A) at HD	1.8 <sup>4</sup>	3.4 <sup>4</sup>	4.8 <sup>4</sup>	5.5 <sup>4</sup>	7.2 <sup>4</sup>	9.2 <sup>4</sup>	14.8 <sup>4</sup>	18 <sup>4</sup>	24 <sup>4</sup>	31 <sup>4</sup>	39 <sup>4</sup>	45 <sup>4</sup>	
	Rated output current (A) at ND <sup>3</sup>	2.1	4.1	5.4	6.9	8.8	11.1	17.5	23	31	38	44	58	
	Max. output voltage	380..480V (proportional to input voltage)												
	Max. output frequency	400 Hz												
Power supply	Rated input voltage and frequency	3-phase 380..480 VAC, 50/60 Hz												
	Allowable voltage fluctuation	-15%..+10%												
	Allowable frequency fluctuation	+5%												
	Input Current (A) at HD <sup>6</sup>	1.8	3.2	4.4	6	8.2	10.4	15	20	29	39	44	49	
	Input Current (A) at ND <sup>6</sup>	2.1	4.3	5.9	8.1	9.4	14	20	24	38	44	52	58	

Specifications

Three-phase: CIMR-A□4A		0072	0088	0103	0139	0165	0208	0250	0296	0362	0414	0515	0675
Motor kW <sup>1</sup>	For HD setting	30	37	45	55	75	90	110	132	160	185	220	315
	For ND setting	37	45	55	75	90	110	132	160	185	220	250	355
Output characteristics	Inverter capacity kVA at HD <sup>2</sup>	48	57	69	85	114	137	165	198	232	282	343	461
	Inverter capacity kVA at ND <sup>2</sup>	55	67	78	106	126	159	191	226	276	316	392	514
	Rated output current (A) at HD	60 <sup>4</sup>	75 <sup>4</sup>	91 <sup>4</sup>	112 <sup>5</sup>	150 <sup>5</sup>	180 <sup>5</sup>	216 <sup>5</sup>	260 <sup>5</sup>	304 <sup>3</sup>	370	450	605
	Rated output current (A) at ND <sup>3</sup>	72	88	103	139	165	208	250	296	362	414	515	675
	Max. output voltage	380..480V (proportional to input voltage)											
	Max. output frequency	400 Hz											
Power supply	Rated input voltage and frequency	3-phase 380..480 VAC, 50/60 Hz											
	Allowable voltage fluctuation	-15%..+10%											
	Allowable frequency fluctuation	+5%											
	Input Current (A) at HD <sup>6</sup>	58	71	86	105	142	170	207	248	300	346	410	584
	Input Current (A) at ND <sup>6</sup>	71	86	105	142	170	207	248	300	346	410	465	657

1. Based on a standard 4-pole motor for maximum applicable motor output:
2. Rated Motor Capacity is calculated with a rated output voltage of 440 V:
3. Carrier frequency is set to 2kHz. Current derating is required in order to raise the carrier frequency:
4. Carrier frequency can be increased up to 8 kHz while keeping this current rating. Higher carrier frequency settings require derating:
5. Carrier frequency can be increased up to 5 kHz while keeping this current rating. Higher carrier frequency settings require derating:
6. Assumes operation at rated output current. Input current rating varies depending on the power supply transformer, input reactor, wiring conditions, and power supply impedance:

Common specifications

Model number CIMR-A	Specifications	
Control functions	Control methods	Sine wave PWM (V/f control, V/f control with PG, Open loop vector control, Closed loop vector control, Open loop vector control for PM, Closed loop vector control for PM, Advanced Open Loop Vector Control for PM)
	Output frequency range	0.01..400 Hz
	Frequency tolerance	Digital set value: ±0.01% of the max. output frequency (-10..+40 °C) Analogue set value: ±0.1% of the max. output frequency (25 ±10 °C)
	Resolution of frequency set value	Digital set value: 0.01 Hz Analogue set value: 0.03 Hz / 60 Hz (11 bit)
	Resolution of output frequency	0.001 Hz
	Frequency set value	-10..+10 V (20 kΩ), 0..10 V (20 kΩ), 4..20 mA (250 Ω), Pulse train input, frequency setting value (selectable)
	Starting Torque	150%/3Hz (V/f control, V/f control with PG), 200%/0.3Hz <sup>+1</sup> (Open loop vector control), 200%/0 r/min <sup>+1</sup> (Closed loop vector control, Closed loop vector control for PM, Advanced Open Loop Vector Control for PM), 100% / 5% speed (Open loop vector control for PM),
	Speed Control Range	1:1500 (Closed loop vector control, Closed loop vector control for PM), 1:200 (Open loop vector control), 1:40 (V/f control, V/f control with PG), 1:20 (Open Loop Vector Control for PM), 1:100 (Advanced Open Loop Vector Control for PM)
	Speed Control Accuracy	±0.2% in Open loop vector control (25 ±10 °C) <sup>+2</sup> , 0.02% in Closed loop vector control (25 ±10 °C)
	Speed Response	10 Hz in Open loop vector control (25 ±10 °C), 50Hz in Closed loop Vector Control (25 ±10 °C), (excludes temperature fluctuation when performing Rotational Auto-Tuning)
	Torque Limit	All Vector Control allows separate settings in four quadrants
	Accel/Decel Time	0.00 to 6000.0 s (4 selectable combinations of independent acceleration and deceleration settings)
	Functionality	Braking torque
V/f Characteristics		User-selected programs and V/f preset patterns possible
Protection functions	Main Control Functions	Torque Control, Droop control, Speed/torque control switching, Feedforward control, Zero-servo control, Momentary power loss ride-thru, Speed search, Overtorque detection, Torque Limit, 17-step speed (max), Accel/Decel time switch S-curve Accel/Decel, 3-wire sequence, Auto-tuning (rotational, stationary), Online Tuning, Dwell Cooling fan on/off switch, slip compensation, Torque compensation, Frequency Jump, Upper/lower limits for frequency, DC injection braking at start and stop, Over excitation braking, High Slip braking, PID control (with sleep function), Energy saving control, MEMOBUS comm. (RS-485/422 max. 115.2kbps), Fault restart, Application presets, Removable terminal block with parameter backup function...
	Motor protection	Motor overheat protection based on output current
	Momentary overcurrent Protection	Drive stops when output current exceeds 200% of Heavy Duty Rating
	Overload Protection	Drive stops after 60 s at 150% of rated output current (Heavy Duty Rating) <sup>+5</sup>
	Overvoltage Protection	200 V class: Stops when DC bus exceeds approx. 410 V, 400 V class: Stops when DC bus exceeds approx. 820V
	Undervoltage Protection	200 V class: Stops when DC bus exceeds approx. 190 V, 400 V class: Stops when DC bus exceeds approx. 380V
	Momentary power loss Ride-Thru	Immediately stop after 15 ms or longer power loss (default), Continuous operation during power loss than 2 s (standard) <sup>+6</sup>
	Heatsink Overheat Protection	Protected by thermister
	Braking Resistance Overheat Protection	Overheat sensor for braking resistor (optional)
	Stall prevention	Stall prevention during acceleration/deceleration and constant speed operation
	Ground fault	Protected by electronic circuit <sup>+7</sup>
	Power charge indication	Charge LED remains lit until DC bus has fallen below approx. 50 V.

Ambient conditions	Area of Use	Indoor (no corrosive gas, dust, etc.)
	Ambient Temperature	-10°C..+50°C(open chassis) up to 60°C with output current derating, -10°C..+40°C (NEMA Type 1)
	Ambient humidity	95% RH or less (without condensation)
	Storage temperature	-20°C..+60°C (short-term temperature during transportation)
	Altitude	Up to 1000 meters (output derating of 1% per 100 m above 1000 m, max. 3000 m)
	Vibration / Shock	10 Hz to 20 Hz, 9.8 m/s <sup>2</sup> max. 20 Hz to 55Hz, 5.9 m/s <sup>2</sup> (200 V: 45kW or more, 400 V: 55kW or more) or 2.0 m/s <sup>2</sup> max. (200 V: 55 kW or less, 400 V: 75 kW or less)
Safety Standard	Safety Standard	EN954-1 safe category 3 stop category 0; EN ISO 13849-1; IEC EN 61508 SIL2
	Protection Design	IP00 open-chassis, IP20, NEMA Type 1 enclosure

- Requires a drive with recommended capacity.
- Speed control accuracy may vary slightly depending on installation conditions or motor used.
- Momentary average deceleration torque refers to the deceleration torque from 60 Hz down to 0 Hz. This may vary depending on the motor.
- If L3-04 is enabled when using a braking resistor or braking resistor unit, the motor may not stop in the specified deceleration time.
- Overload protection may be triggered when operating with 150% of the rated output current, if the output frequency is less than 6 Hz.
- Varies in accordance with the drive capacity and load. Drives with a capacity of smaller than 11 kW in the 200 V (model CIMR- AA0056 or 400 V (model CIMR- AA0031) require a separate Momentary Power Loss Unit to continue operating.
- Protection may not be provided under the following conditions as the motor windings are grounded internally during run: #Low resistance to ground from the motor cable or terminal block. #Drive already has a short-circuit when the power is turned on.

Dimensions

Open-Chassis [IP00]

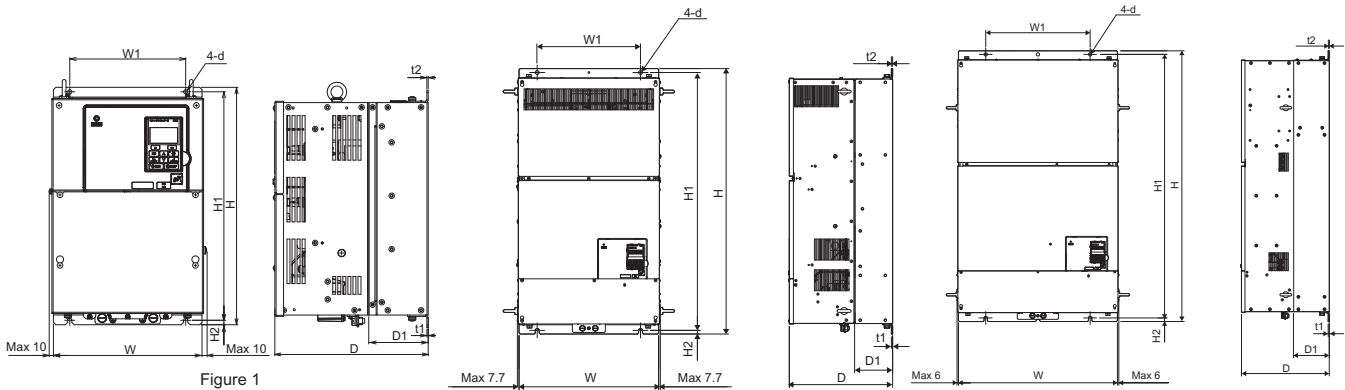

Figure 1

Figure 2

Figure 3

Voltage class	Max. applicable motor output kW		Inverter model CIMR-A□	Figure	Dimensions in mm										Weight (kg)
	ND	HD			W	H	D	W1	H1	H2	D1	t1	t2	d	
Three-phase 200 V	30	22	0110	1	250	400	258	195	385	7.5	100	2.3	2.3	M6	21
	37	30	0138		275	450		220	435						25
	45	37	0169		325	550	283	260	535		110	3.2	3.2	M10	37
	55	45	0211							76					
	75	55	0250		450	705	330	325	680	12.5	130	4.5	4.5	M12	38
	90	75	0312												80
	110	90	0360		500	800	350	370	773	13	130	4.5	4.5	M12	98
110	110	0415	99												
Three-phase 400 V	30	22	0058	1	250	400	258	195	385	7.5	100	2.3	2.3	M6	21
	37	30	0072		275	450		220	435						25
	45	37	0088		325	510	283	260	495		7.5	105	2.3	3.2	M6
	55	45	0103							36					
	75	55	0139		325	550	283	260	535	7.5	110	2.3	2.3	M6	41
	90	75	0165												42
	110	90	0208		450	705	330	325	680	12.5	130	3.2	3.2	M10	79
	132	110	0250	96											
	160	132	0296	500	800	350	370	773	13	130	4.5	4.5	M12	102	
	185	160	0362											107	
	220	185	0414	500	950	370	370	923	13	135	4.5	4.5	M12	125	
	250	220	0515											216	
	355	315	0675	3	670	1140	370	440	1110	15	150	4.5	4.5	M12	221

Enclosed Panel [NEMA Type1]

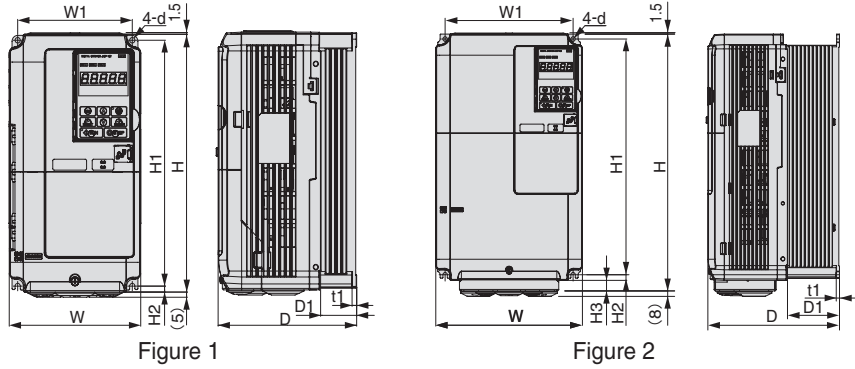

Voltage class	Max. applicable motor output kW		Inverter model CIMR-A□	Figure	Dimensions in mm										Weight (kg)	
	ND	HD			W	H	D	W1	H1	H2	D1	t1	t2	d		
Three-phase 200 V	0.75	0.4	0004	1	140	260	147	122	248	6	38	5	-	M5	3.1	
	1.1	0.75	0006				3.1									
	2.2	1.5	0010				3.2									
	3	2.2	0012				3.2									
	5.5	4.0	0021				3.5									
	7.5	5.5	0030				4.0									
	11	7.5	0040				4.0									
	15	11	0056				5.6									
	18.5	15	0069				8.7									
Three-phase 200 V	22	18.5	0081	2	220	350	197	192	335	8	78	-	M6	9.7		
	Three-phase 400 V	0.75	0.4	0002	1	140	260	147	122	248	6	38	5	-	M5	3.2
		1.5	0.75	0004				3.2								
		2.2	1.5	0005				3.2								
		3	2.2	0007				3.4								
		4.0	3	0009				3.5								
		5.5	4.0	0011				3.5								
		7.5	5.5	0018				3.9								
		11	7.5	0023				3.9								
15		11	0031	5.4												
Three-phase 400 V	18.5	15	0038	1	180	300	187	160	284	8	75	-	M5	5.7		
	22	18.5	0044	2	220	350	197	192	335	8	78	-	M6	8.3		

Schaffner Flat Filters

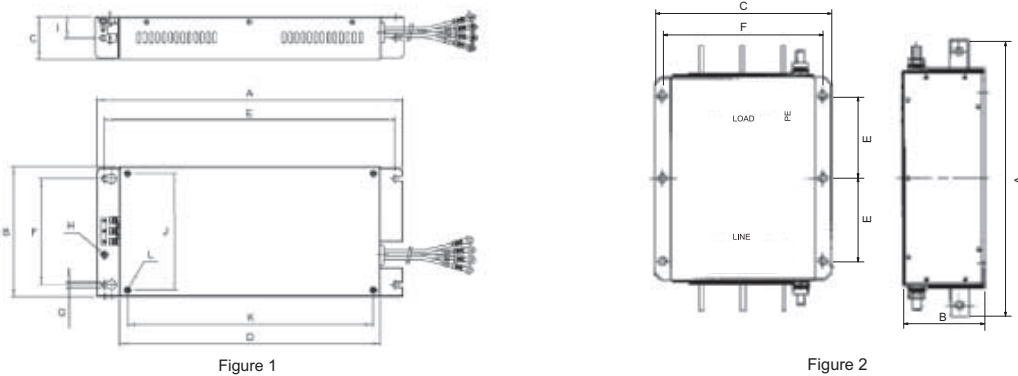

Flat Filters		Fig	Dimensions										Weight KG
			A	B	C	D	E	F	G	H	I	L	
200 V	3G3RV-PFI2035-SE	1	330	141	46	281	313	115	5.5	M5	23	M5	1.4
	3G3RV-PFI2060-SE		355	206	60	302	336	175	6.5	M6	30	M6	3
	3G3RV-PFI2100-SE		408	236	80	355	390	205	6.5	M6	40	M6	4.9
400 V	3G3RV-PFI3010-SE	1	330	141	46	281	313	115	5.5	M4	23	M5	1.2
	3G3RV-PFI3018-SE		330	141	46	281	313	115	5.5	M4	23	M5	1.3
	3G3RV-PFI3035-SE		355	206	50	302	336	175	6.5	M5	25	M6	2.2
	3G3RV-PFI3060-SE	2	408	236	65	355	390	205	6.5	M6	32.5	M6	4
	3G3RV-PFI3410-SE		386	115	260	-	120	235	12.0	M12	-	-	8.5
	3G3RV-PFI3600-SE		386	135	260	-	120	235	12.0	M12	-	-	11.0
	3G3RV-PFI3800-SE		564	160	300	-	210	275	9.0	M12	-	-	31.0

## Bookform Filters

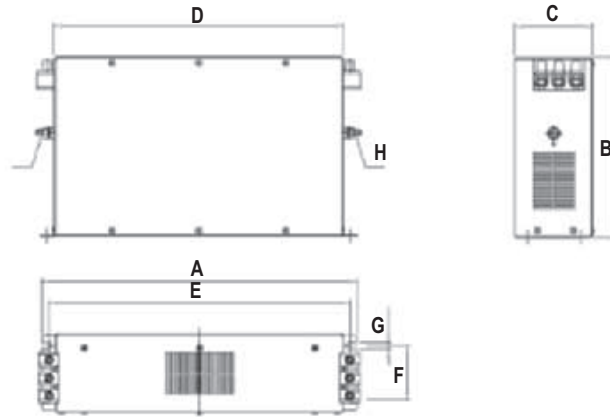

Bookform Filters		Dimensions								Weight KG
		A	B	C	D	E	F	G	H	
200 V	3G3RV-PFI2130-SE	310	180	90	280	295	65	6.5	M10	4.3
	3G3RV-PFI2160-SE	380	170	120	350	365	102	6.5	M10	6.0
	3G3RV-PFI2200-SE	518	240	130	480	498	90	8.2	M10	11.0
400 V	3G3RV-PFI3070-SE	329	185	80	300	314	55	6.5	M6	3.4
	3G3RV-PFI3130-SE	310	180	90	280	295	65	6.5	M10	4.7
	3G3RV-PFI3170-SE	380	170	120	350	365	102	6.5	M10	6.0
	3G3RV-PFI3250-SE	610	240	130	480	498	90	8.3	M10	11.7
	3G3RV-PFI3410-SE	386	115	260	-	120	235	12.0	M12	8.5
	3G3RV-PFI3600-SE	386	135	260	-	120	235	12.0	M12	11.0
	3G3RV-PFI3800-SE	564	160	300	-	210	275	9.0	M12	31.0

## Remote LCD operator

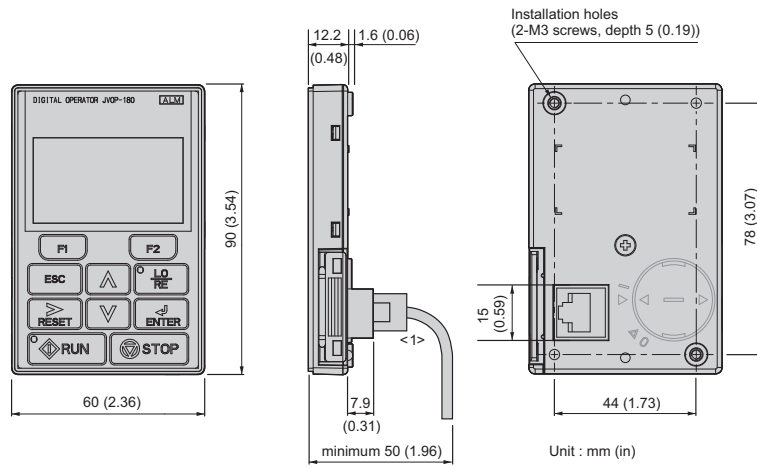

## Chokes

Description	D diameter	Motor KW	Dimensions						Weight Kg
			L	W	H	X	Y	m	
A1000-FEV2102-RE	21	< 2.2	85	22	46	70	-	5	0.1
A1000-FEV2515-RE	25	< 15	105	25	62	90	-	5	0.2
A1000-FEV5045-RE	50	< 45	150	50	110	125	30	5	0.7
A1000-FEV6045-RE	60	> 45	200	65	170	180	45	6	1.7

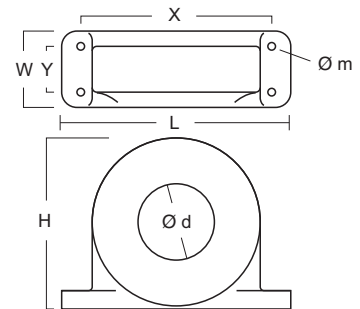

Braking Unit

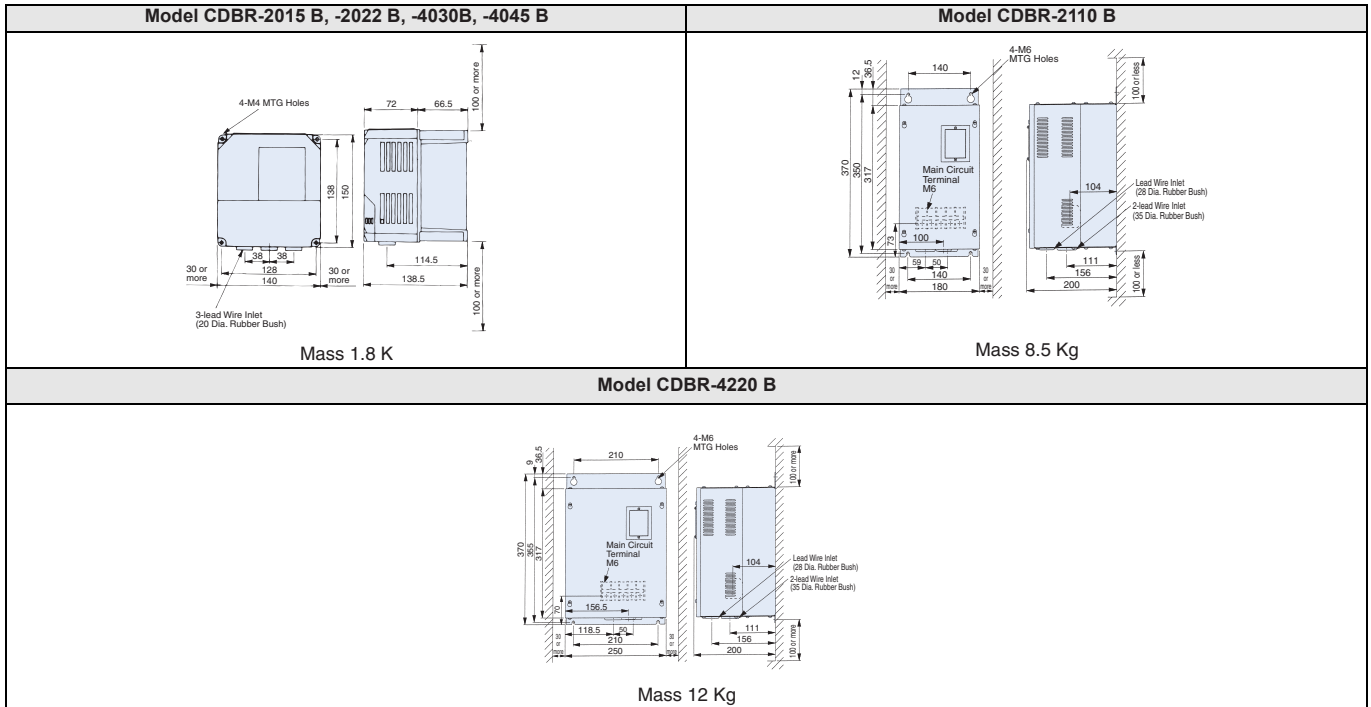

Resistor Dimensions  
A1000-REJ0K15

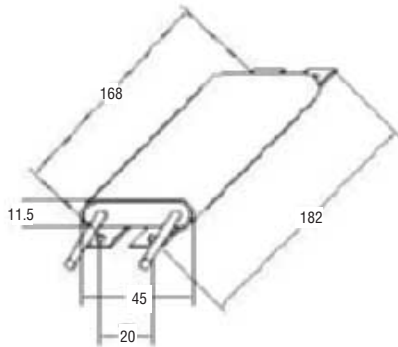

A1000-REJ0K10

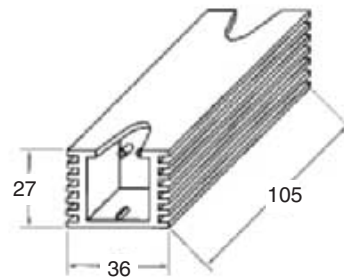

Braking Resistor Unit

Voltage	Model LKEB-__	Dimensions in mm					MTG Screw	Mass kg
		A	B	C	D			
220 V Class	21P5	130	350	75	335	M5 x 3	4.5	
	22P2							
	23P7							
	25P5	250	350	200	335	M6 x 4	7.5	
	27P5						8.5	
	2011	266	543	246	340	M8 x 4	10	
	2015	356	543	336	340	M8 x 4	15	
	2018	446	543	426	340	M8 x 4	19	
2022								
400 V Class	41P5	130	350	75	335	M5 x 4	4.5	
	42P2							
	43P7	250	350	200	335	M6 x 4	5.0	
	45P5						7.5	
	47P5						8.5	
	4011	350	412	330	325	M6 x 4	16	
	4015	446	543	426	340	M8 x 4	19	
	4018							
	4022							
	4030	356	956	336	740	M8 x 4	25	
	4037	446	956	426	740	M8 x 4	33	
4045	446	956	426	740	M8 x 4	33		

Fig 1

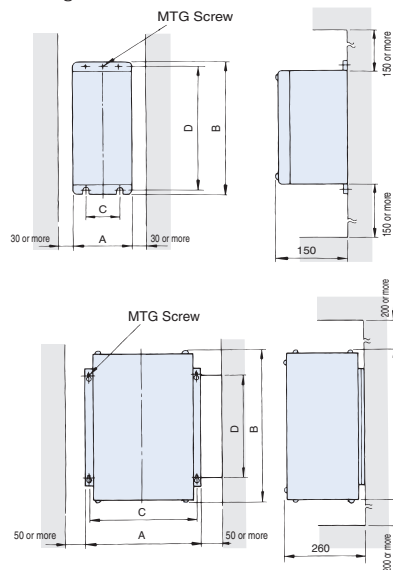

Installation

Standard connections

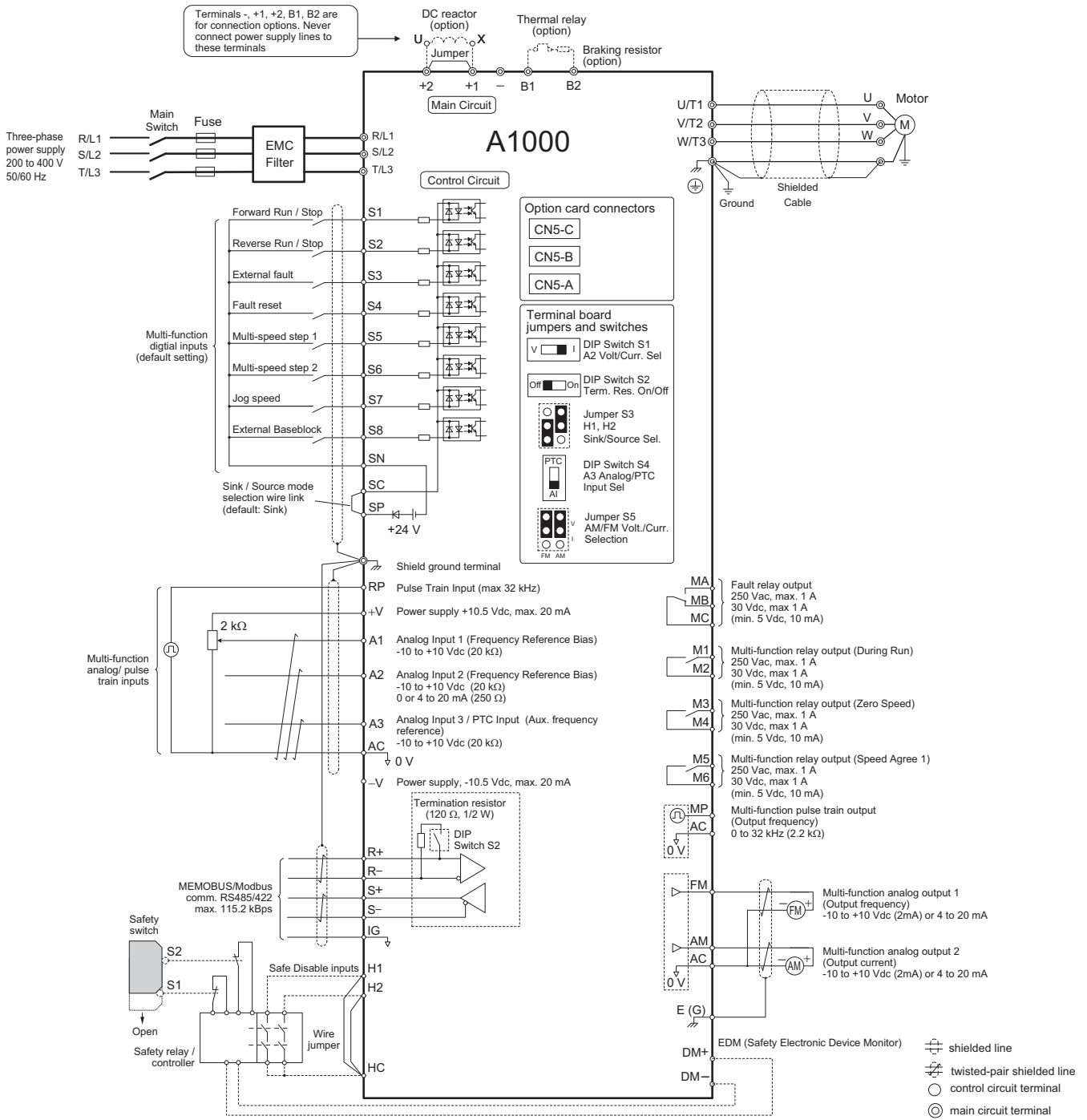

Main circuit

Terminal	Name	Function (signal level)
R/L1, S/L2, T/L3	Main circuit power supply input	Used to connect line power to the drive.
U/T1, V/T2, W/T3	Inverter output	Used to connect the motor
B1, B2	Braking resistor connection	Available for connecting a braking resistor or the braking resistor unit option.
+2, +1	DC reactor connection	Remove the short bar between +2 and +1 when connecting DC reactor (option)
+1, -	DC power supply input	For power supply input (+1: positive electrode; - : negative electrode)*
+3	Braking Unit	Connection for Braking Unit between terminals +3 and -
⊕	Grounding	For grounding (grounding should conform to the local grounding code.)



Control Circuit

Type	No.	Signal name	Function	Signal level	
Digital input signals	S1	Multi-function input selection 1	Factory setting: runs when CLOSED, stops when OPEN.	24 VDC, 8 mA photocoupler insulation	
	S2	Multi-function input selection 2	Factory setting: runs when CLOSED, stops when OPEN.		
	S3	Multi-function input selection 3	Factory setting: External Fault (N.O.)		
	S4	Multi-function input selection 4	Factory setting: Fault reset		
	S5	Multi-function input selection 5	Factory setting: Multi-step speed cmd 1		
	S6	Multi-function input selection 6	Factory setting: Multi-step speed cmd 2		
	S7	Multi-function input selection 7	Factory setting: Jog Frequency		
	S8	Multi-function input selection 8	Factory setting: Closed gives external baseblock		
	SC	Multi-function input selection Common	Common for control signal		
Analog input signals	+V	Power Supply for Frequency Setting	+10.5 V (allowable max current 20 mA)		
	-V	Power Supply for Frequency Setting	-10.5 V (allowable max current 20 mA)		
	A1	Multi-function analogue input 1	Main Frequency Reference -10 to +10 VDC, 0 to +10 VDC (20 kΩ)		
	A2	Multi-function analogue input 2	Voltage input or current input -10 to +10 VDC, 0 to +10 VDC (20 kΩ) 4 to 20 mA (250 Ω)		
	A3	Multi-function analogue input 3	-10 to +10 V, 0 to +10 V (20 kΩ)		
	AC	Frequency reference common	0 V		
Safety input	HC	Safety Input Common	+24 V (max allowable current 10 mA)		
	H1	Safety Input 1	Open: Stop Closed: Normal Operation	Photocoupler 24 V DC, 8 mA	
	H2	Safety Input 2			
Safety monitor output	DM+	Safety monitor output	Open: Safety inputs 1 and 2 are open	48 Vdc, 50mA or less	
	DM-	Safety monitor output common			
Digital output signals	MA	NO contact output	Factory setting: "fault"	Contact capacity 250 VAC, 1 A or less 30 VDC, 1 A or less	
	MB	NC Output			
	MC	Relay Output common			
	M1	Multi-function contact output (N.O )	Factory setting Closed: During run		
	M2				
	P1	Photocoupler output 1	Factory setting: Zero speed		Photocoupler output: +48 VDC, 50 mA or less
	P2	Photocoupler output 2	Factory setting: Frequency Agree		
PC	Photocoupler output common	0 V			
Analog output signals	FM	Multi-function analog monitor (1)	Factory setting: Output frequency	-10 to 10 V ±5%, (2 mA or less) 0 to 10 V 4 - 20 mA	
	AM	Multi-function analog monitor (2)	Factory setting: "Current monitor, 5 V/drive rated current		
	AC	Analog monitor common	0 V		
Pulse/O	RP	Main Speed Cmd Pulse Train Input	32 kHz max. (3 kΩ)		
	MP	Pulse Train Output	Factory setting: Frequency reference input (H6-01=0) 0 to 33 kHz (2.2 kΩ)		
RS-485/422	R+	Communication input (+)	For MEMOBUS communication operation by RS-485 or RS-422 communication is available.	RS-485/422 MEMOBUS protocol	
	R-	Communication input (-)			
	S+	Communication output (+)			
	S-	Communication output (-)			

Inverter heat loss

Three-phase 200 V class

Model Number CIMR-A□	Heavy Duty				Normal Duty			
	Rated Amps (A)	Heatsink Loss (W)	Interior Unit Loss (W)	Total Loss (W)	Rated Amps (A)	Heatsink Loss (W)	Interior Unit Loss (W)	Total Loss (W)
2A0004	3.2	14.8	44	59	3.5	18.4	47	66
2A0006	5.0	24	48	72	6.0	31	51	82
2A0010	8.0	43	52	95	9.6	57	58	115
2A0012	11.0	64	58	122	12.0	77	64	141
2A0021	17.5	101	67	168	21	138	83	222
2A0030	25	194	92	287	30	262	117	379
2A0040	33	214	105	319	40	293	145	437
2A0056	47	280	130	410	56	371	175	546
2A0069	60	395	163	558	69	491	205	696
2A0081	75	460	221	681	81	527	257	785
2A0110	85	510	211	721	110	719	286	1005
2A0138	115	662	250	912	138	842	312	1154
2A0169	145	816	306	1122	169	1014	380	1394
2A0211	180	976	378	1354	211	1218	473	1691
2A0250	215	1514	466	1980	250	1764	594	2358
2A0312	283	1936	588	2524	312	2020	665	2686
2A0360	346	2564	783	3347	360	2698	894	3591
2A0415	415	2672	954	3626	415	2672	954	3626

Three-phase 400 V class

Model Number CIMR-A□	Heavy Duty				Normal Duty			
	Rated Amps (A)	Heatsink Loss (W)	Interior Unit Loss (W)	Total Loss (W)	Rated Amps (A)	Heatsink Loss (W)	Interior Unit Loss (W)	Total Loss (W)
4A0002	1.8	15.9	45	61	2.1	20	48	68
4A0004	3.4	25	46	70	4.1	32	49	81
4A0005	4.8	37	49	87	5.4	45	53	97
4A0007	5.5	48	53	101	6.9	62	59	121
4A0009	7.2	53	55	108	8.8	66	60	126
4A0011	9.2	69	61	130	11.1	89	73	162
4A0018	14.8	135	86	221	17.5	177	108	285
4A0023	18.0	150	97	247	23	216	138	354
4A0031	24	208	115	323	31	295	161	455
4A0038	31	263	141	403	38	340	182	521
4A0044	39	330	179	509	44	390	209	599
4A0058	45	349	170	518	58	471	215	686
4A0072	60	484	217	701	72	605	265	870
4A0088	75	563	254	817	88	684	308	993
4A0103	91	723	299	1022	103	848	357	1205
4A0139	112	908	416	1325	139	1215	534	1749
4A0165	150	1340	580	1920	165	1557	668	2224
4A0208	180	1771	541	2313	208	1800	607	2408
4A0250	216	2360	715	3075	250	2379	803	3182
4A0296	260	2391	787	3178	296	2448	905	3353
4A0362	304	3075	985	4060	362	3168	1130	4298
4A0414	370	3578	1164	4742	414	3443	1295	4738
4A0515	450	3972	1386	5358	515	4850	1668	6518
4A0675	605	4191	1685	5875	675	4861	2037	6898

Connections for braking unit and braking resistor

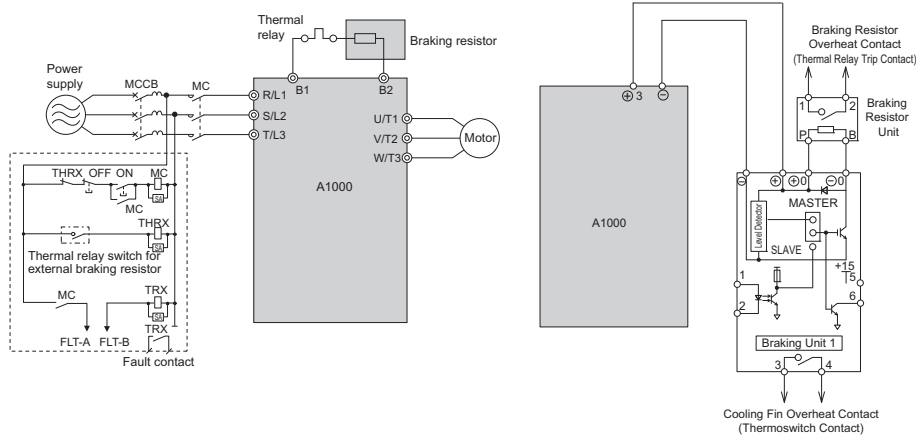

AC reactor

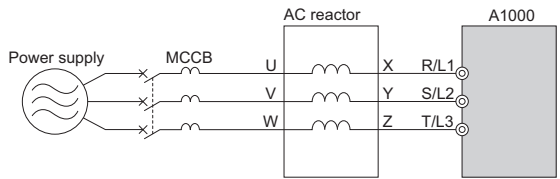

200 V class			400 V class		
Max. applicable motor output kW	Current value A	Inductance mH	Max. applicable motor output kW	Current value A	Inductance mH
0.4	2.5	4.2	0.4	1.3	18
0.75	5	2.1	0.75	2.5	8.4
1.5	10	1.1	1.5	5	4.2
2.2	15	0.71	2.2	7.5	3.6
4.0	20	0.53	4.0	10	2.2
5.5	30	0.35	5.5	15	1.42
7.5	40	0.265	7.5	20	1.06
11	60	0.18	11	30	0.7
15	80	0.13	15	40	0.53
18.5	90	0.12	18.5	50	0.42
22	120	0.09	22	60	0.36
30	160	0.07	30	80	0.28
37	200	0.05	37	90	0.24
45	240	0.044	45	120	0.18
55	280	0.039	55	150	0.15
75	360	0.026	75	200	0.11
90	500	0.02	90/110	250	0.09
110	600	0.02	132/160	330	0.06
-	-	-	160/185/220	490	0.04
-	-	-	315	660	0.03

DC reactor

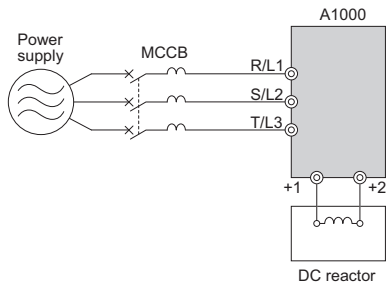

200 V class			400 V class		
Max. applicable motor output kW	Current value A	Inductance mH	Max. applicable motor output kW	Current value A	Inductance mH
0.4	5.4	8	0.4	3.2	28
0.75					
1.5	18	3	1.5	5.7	11
2.2					
4.0					
5.5	36	1	5.5	23	3.6
7.5					
11	72	0.5	11	33	1.9
15					
18.5	90	0.4	18.5	47	1.3
22 to 110			Built-in		

**Safety System**

- A1000 provides Safe Torque Off (STO) functional safety in compliance with EN954-1 safety category 3 stop category 0, EN ISO 13849-1, PLC, IEC/EN61508 SIL2.
- An External Device Monitor (EDM) function has also been added to monitor the safety status of the drive.

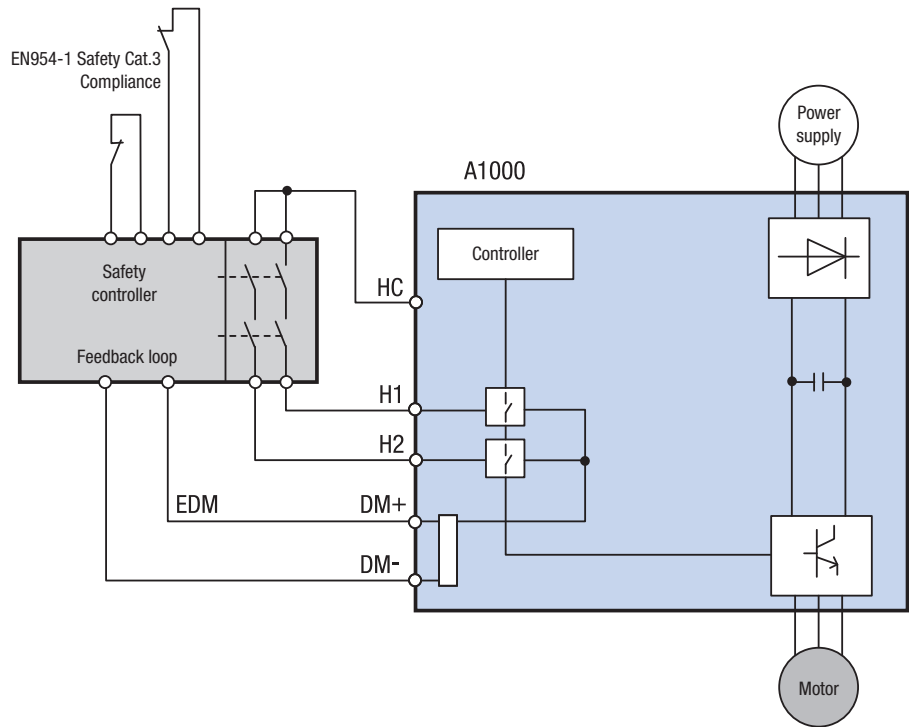

Ordering information

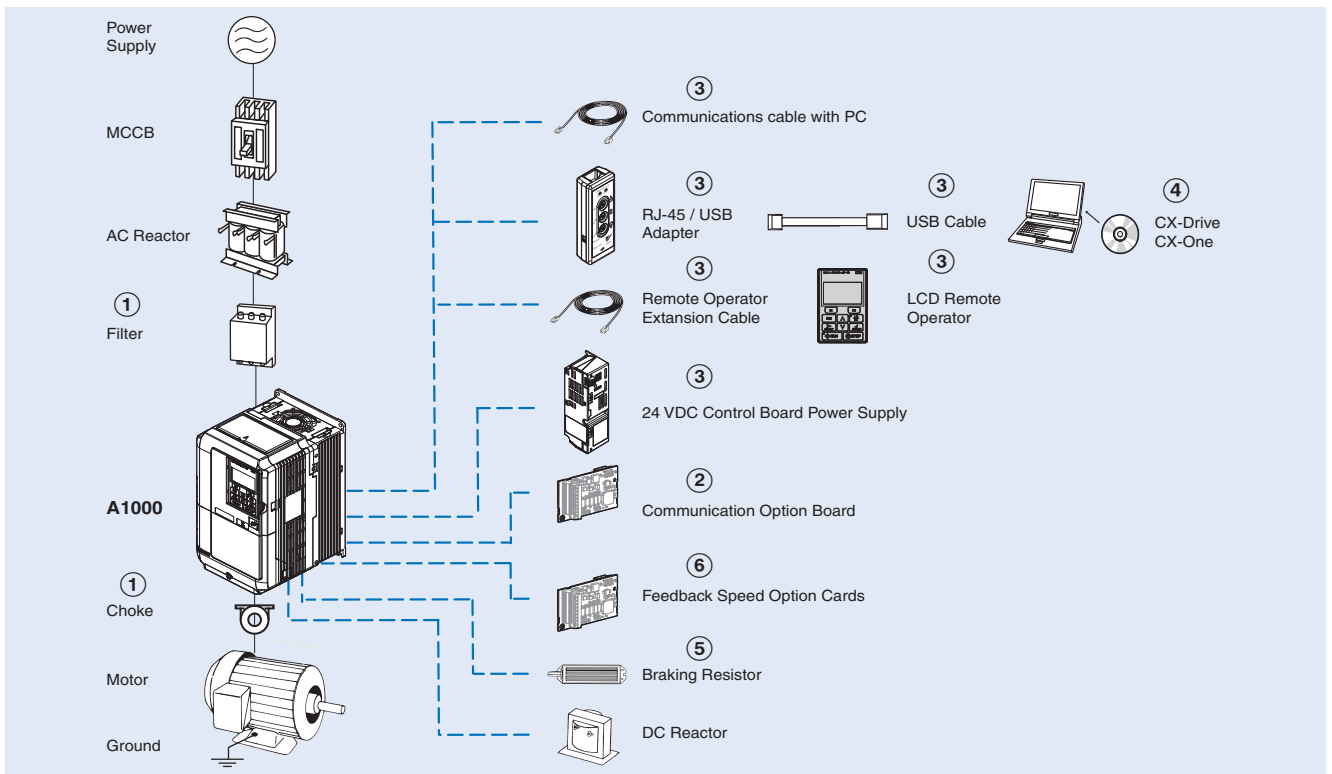

A1000

	Specifications				Model
	Heavy Duty		Normal Duty		Standard
200 V	0.4 kW	3.2 A	0.75 kW	3.5 A	CIMR-AC2A0004FAA
	0.75 kW	5.0 A	1.1 kW	6.0 A	CIMR-AC2A0006FAA
	1.5 kW	8.0 A	2.2 kW	9.6 A	CIMR-AC2A0010FAA
	2.2 kW	11.0 A	3.0 kW	12.0 A	CIMR-AC2A0012FAA
	4.0 kW	17.5 A	5.5 kW	21.0 A	CIMR-AC2A0021FAA
	5.5 kW	25.0 A	7.5 kW	30.0 A	CIMR-AC2A0030FAA
	7.5 kW	33.0 A	11.0 kW	40.0 A	CIMR-AC2A0040FAA
	11 kW	47.0 A	15.0 kW	56.0 A	CIMR-AC2A0056FAA
	15 kW	60.0 A	18.5 kW	69.0 A	CIMR-AC2A0069FAA
	18.5 kW	75 A	22 kW	81 A	CIMR-AC2A0081FAA
	22 kW	85 A	30 kW	110 A	CIMR-AC2A0110AAA
	30 kW	115 A	37 kW	138 A	CIMR-AC2A0138AAA
	37 kW	145 A	45 kW	169 A	CIMR-AC2A0169AAA
	45 kW	180 A	55 kW	211 A	CIMR-AC2A0211AAA
	55 kW	215 A	75 kW	250 A	CIMR-AC2A0250AAA
	75 kW	283 A	90 kW	312 A	CIMR-AC2A0312AAA
90 kW	346 A	110 kW	360 A	CIMR-AC2A0360AAA	
110 kW	415 A	110 kW	415 A	CIMR-AC2A0415AAA	
400 V	0.4 kW	1.8 A	0.75 kW	2.1 A	CIMR-AC4A0002FAA
	0.75 kW	3.4 A	1.5 kW	4.1 A	CIMR-AC4A0004FAA
	1.5 kW	4.8 A	2.2 kW	5.4 A	CIMR-AC4A0005FAA
	2.2 kW	5.5 A	3.0 kW	6.9 A	CIMR-AC4A0007FAA
	3.0 kW	7.2 A	4.0 kW	8.8 A	CIMR-AC4A0009FAA
	4.0 kW	9.2 A	5.5 kW	11.1 A	CIMR-AC4A0011FAA
	5.5 kW	14.8 A	7.5 kW	17.5 A	CIMR-AC4A0018FAA
	7.5 kW	18.0 A	11.0 kW	23.0 A	CIMR-AC4A0023FAA
	11 kW	24.0 A	15.0 kW	31.0 A	CIMR-AC4A0031FAA
	15 kW	31.0 A	18.5 kW	38.0 A	CIMR-AC4A0038FAA
	18.5 kW	39 A	22 kW	44 A	CIMR-AC4A0044FAA
	22 kW	45 A	30 kW	58 A	CIMR-AC4A0058AAA
	30 kW	60 A	37 kW	72 A	CIMR-AC4A0072AAA
	37 kW	75 A	45 kW	88 A	CIMR-AC4A0088AAA
	45 kW	91 A	55 kW	103 A	CIMR-AC4A0103AAA
	55 kW	112 A	75 kW	139 A	CIMR-AC4A0139AAA
	75 kW	150 A	90 kW	165 A	CIMR-AC4A0165AAA
	90 kW	180 A	110 kW	208 A	CIMR-AC4A0208AAA
	110 kW	216 A	132 kW	250 A	CIMR-AC4A0250AAA
	132 kW	260 A	160 kW	296 A	CIMR-AC4A0296AAA
160 kW	304 A	185 kW	362 A	CIMR-AC4A0362AAA	
185 kW	370 A	220 kW	414 A	CIMR-AC4A0414AAA	
220 kW	450 A	250 kW	515 A	CIMR-AC4A0515AAA	
315 kW	605 A	355 kW	675 A	CIMR-AC4A0675AAA	

① Line filters

Inverter		Line filter		
Voltage	Model CIMR-A□	Reference	Rated current (A)	Weight (kg)
3-Phase 200 VAC	2CA0004 / 2CA0006 / 2CA0008	3G3RV-PFI3010-SE	10	1.2
	2CA0010 / 2CA0012 / 2CA0018 / 2CA0021	3G3RV-PFI3018-SE	18	1.3
	2CA0030 / 2CA0040 / 2CA0056	3G3RV-PFI2035-SE	35	1.4
	2CA0069 / 2CA0081	3G3RV-PFI2060-SE	60	3
	2CA00110 / 2CA0138	3G3RV-PFI2100-SE	100	4.9
	2CA0169 / 2CA0211	3G3RV-PFI3170-SE	170	6.0
3-Phase 400 VAC	4CA0002 / 4CA0004 / 4CA0005 / 4CA0007	3G3RV-PFI3010-SE	10	1.2
	4C0009 / 4C0011	3G3RV-PFI3018-SE	18	1.3
	4CA0018 / 4CA0023 / 4CA0031	3G3RV-PFI3035-SE	35	2.2
	4CA0038 / 4CA0044 / 4CA0058	3G3RV-PFI3060-SE	60	4.0
	4CA0072 / 4CA0088	3G3RV-PFI3100-SE	100	4.5
	4CA0103 / 4CA0139 / 4CA0165	3G3RV-PFI3170-SE	170	6.0
	4CA0208 / 4CA0250	3G3RV-PFI3200-SE	250	11
	4CA0296 / 4CA0362	3G3RV-PFI3400-SE	400	8.5
	4CA0414 / 4CA0515	3G3RV-PFI3600-SE	600	11.0
4CA0675	3G3RV-PFI3800-SE	800	31.0	

Chokes

Model	Diameter	Description
A1000-FEV2102-RE	21	Recommended for motors below 2.2 KW
A1000-FEV2515-RE	25	Recommended for motors below 15 KW
A1000-FEV5045-RE	50	Recommended for motors below 45 KW
A1000-FEV6045-RE	60	Recommended for motors above 45 KW

② Communication cards

Type	Model	Description	Function
Communication option board	SI-N3	DeviceNet option card	• Used for running or stopping the inverter, setting or referencing parameters, and monitoring output frequency, output current, or similar items through DeviceNet communication with the host controller.
	SI-P3	PROFIBUS-DP option card	• Used for running or stopping the inverter, setting or referencing parameters, and monitoring output frequency, output current, or similar items through PROFIBUS-DP communication with the host controller.
	SI-S3	Can open option card	• Used for running or stopping the inverter, setting or referencing parameters, and monitoring output frequency, output current, or similar items through CANopen communication with the host controller.
	SI-T3	Mechatrolink II option card	• Used for running or stopping the inverter, setting or referencing parameters, and monitoring output frequency, output current, or similar items through Mechatrolink II communication with the host controller.

③ Accessories

Types	Model	Description	Functions
Digital operator	JVOP-180	LCD remote operator	LCD Display operator with language support
	3G3AX-CAJOP300-EE	Remote operator cable	3 meters cable for connecting remote operator
Accessories	JVOP-181	USB converter / USB cable	USB converter unit with copy and backup function
	PS-V10S	24 VDC option board	24V DC control board power supply VZA-B/2/4 from 0.1 to 4 KW
	PS-V10M		24V DC control board power supply VZA-2/4 from 5.5 to 15 KW
	A1000-CAVPC232-EE	PC connection cable	RS232 PC tool connection cable

④ Computer software

Types	Model	Description	Installation
Software	CX-drive	Computer software	Configuration and monitoring software tool
	CX-One	Computer software	Configuration and monitoring software tool

⑤ Braking unit, braking resistor unit

Inverter		Braking unit		Braking Resistor <sup>1</sup>															
Max. Applicable Motor kW	Model CIMR-A□2A	Model CDBR	No. of used	Model A1000-RE	Specifications of Resistor		Qty	Braking torque % (3% ED)	Model LKEB-	Specifications of Resistor		Qty	Braking torque % (10% ED)	Min Resist Value Ω					
200 V Class	0.4	0004 HD	Built-in	-	190W	200 Ω	1	220	-	-	-	-	-	48					
	0.75	0004 ND						J0K15200-IE	125	-	-	-	-	-	-	-	-	-	48
		0006 HD																	
	1.1	0006 ND						J0K15100-IE	85	-	-	-	-	-	-	-	-	-	48
		0008 HD																	
	1.5	0008 ND						190 W	100 Ω	1	150	21P5	260W	100Ω	1	150	1	125	48
		0010 HD																	
	2.2	0010 ND						J0K15070-IE	120	-	-	-	-	-	-	-	-	-	48
		0012 HD																	
	3	0012 ND						190 W	62 Ω	1	100	23P7	390W	40Ω	1	150	1	120	16
		0018 HD																	
	3.7	0018 ND						J0K15062-IE	80	-	-	-	-	-	-	-	-	-	16
		0021 HD																	
	5.5	0021 ND						-	-	-	-	-	-	-	-	-	-	-	16
		0030 HD																	
	7.5	0030 ND						-	-	-	-	-	-	-	-	-	-	-	16
		0040 HD																	
	11	0040 ND						-	-	-	-	-	-	-	-	-	-	-	9.6
		0056 HD																	
	15	0056 ND						-	-	-	-	-	-	-	-	-	-	-	9.6
		0069 HD																	
	18.5	0069 ND						-	-	-	-	-	-	-	-	-	-	-	9.6
		0081 HD																	
	22	0081 ND						-	-	-	-	-	-	-	-	-	-	-	9.6
0110 HD																			
30	0110 ND	-	-	-	-	-	-	-	-	-	-	-	6.4						
	0138 HD																		
37	0138 ND	-	-	-	-	-	-	-	-	-	-	-	6.4						
	0169 HD																		
45	0169 ND	2015B	2	-	-	-	-	-	-	-	-	-	-						
	0211 HD	2022B	2	-	-	-	-	-	-	-	-	-	-						
55	0211 ND	-	-	-	-	-	-	-	-	-	-	-	6.4						
	0250 HD																		
75	0250 ND	-	-	-	-	-	-	-	-	-	-	-	6.4						
	0312 HD																		
90	0312 ND	-	-	-	-	-	-	-	-	-	-	-	1.6						
	0360 HD																		
110	0360 ND	-	-	-	-	-	-	-	-	-	-	-	1.6						
	0415 HD																		
400 V Class	0.4	0002 HD	Built in	-	60 W	750 Ω	1	230	-	-	-	-	-	96					
	0.75	0002 ND						J0K10750-IE	130	-	-	-	-	-	-	-	-	-	96
		0004 HD																	
	1.5	0004 ND						-	-	-	-	-	-	-	-	-	-	-	96
		0005 HD																	
	2.2	0005 ND						-	-	-	-	-	-	-	-	-	-	-	64
		0007 HD																	
	3	0007 ND						-	-	-	-	-	-	-	-	-	-	-	64
		0009 HD																	
	3.7	0009 ND						-	-	-	-	-	-	-	-	-	-	-	32
		0011 HD																	
	5.5	0011 ND						-	-	-	-	-	-	-	-	-	-	-	32
		0018 HD																	
	7.5	0018 ND						-	-	-	-	-	-	-	-	-	-	-	32
		0023 HD																	
	11	0023 ND						-	-	-	-	-	-	-	-	-	-	-	32
		0031 HD																	
	15	0031 ND						-	-	-	-	-	-	-	-	-	-	-	20
		0038 HD																	
	18.5	0038 ND						-	-	-	-	-	-	-	-	-	-	-	20
		0044 HD																	
	22	0044 ND						-	-	-	-	-	-	-	-	-	-	-	19.2
		0058 HD																	
	30	0058 ND						-	-	-	-	-	-	-	-	-	-	-	19.2
0072 HD																			
37	0072 ND	-	-	-	-	-	-	-	-	-	-	-	19.2						
	0088 HD																		
45	0088 ND	4045B	1	-	-	-	-	-	-	-	-	-	-						
	0103 HD	4045B	1	-	-	-	-	-	-	-	-	-	-						
55	0103 ND	-	-	-	-	-	-	-	-	-	-	-	12.8						
	0139 HD																		
75	0139 ND	-	-	-	-	-	-	-	-	-	-	-	12.8						
	0165 HD																		
90	0165 ND	-	-	-	-	-	-	-	-	-	-	-	12.8						
	0208 HD																		
110	0208 ND	-	-	-	-	-	-	-	-	-	-	-	3.2						
	0250 HD																		

Inverter		Braking unit			Braking Resistor <sup>1</sup>									
					Type									
Max. Applicable Motor kW	Model CIMR-A□2A	Model CDBR_	No. of used	Model A1000-RE_	Specifications of Resistor	Qty	Braking torque % (3% ED)	Model LKEB-	Specifications of Resistor		Qty	Braking torque % (10% ED)	Min Resist Value Ω	
400 V Class	132	0250 ND	4220B	1	-			4045	9600W	13.6Ω	4	140	3.2	
		0296 HD			-									
	160	0296 ND	4220B	1	-									
		0362 HD			-									
	185	0362 ND	4220B	1	-									
		0414 HD			-									
	220	0414 ND	4220B	1	-			4037	9600W	16Ω	5	110	95	3.2
		0515 HD			-									
250	0515 ND	4220B	1	-	4045	9600W	13.6Ω	6	105	90	3.2			
315	0675 HD	4220B	2	-										
355	0675 ND	4220B	2	-										

1. When connecting a mounting type resistor or braking resistor unit, set system constant L3-04 to 0 (Stall prevention disabled during deceleration). Motor will not stop at set deceleration time if this constant is not changed. Additionally the Internal braking transistor protection (L8-55) should be set to "0" when a external braking unit (CDBR-) is used.

⑥ Feedback speed option card

Type	Model	Description	Function
PG option card	PG-B3	Complementary PG	<ul style="list-style-type: none"> <li>For speed feedback input by connecting a motor encoder Input: 3 track (one or two tracks), for HTL encoder connection, 50 KHz max Output: 3 track open collector Encoder power supply: 12 V, 200 mA max</li> </ul>
	PG-X3	Line Driver PG	<ul style="list-style-type: none"> <li>For speed feedback input by connecting a motor encoder Input: 3 track, line driver, 300 kHz max Output: 3 track, line driver Encoder power supply: 5 V or 12 V, 200 mA max</li> </ul>

ALL DIMENSIONS SHOWN ARE IN MILLIMETERS.  
To convert millimeters into inches, multiply by 0.03937. To convert grams into ounces, multiply by 0.03527.