



Modbus communication set for Varlogic NRC12 power factor controller

User manual

DB121286



Schneider
Electric

NRC12
Modbus application
USER'S MANUAL

1 Table of Contents

1	Table of Contents	2
2	Glossary	3
3	NRC12 Modbus in general	3
4	Entire system	4
4.1	PFC to PC connection alternatives	4
4.1.1	One PFC.....	4
4.1.2	Many PFCs system	5
5	Physical connections	5
5.1	Fiber optic connection.....	5
5.2	RS-485 interface	5
5.3	2-wire connection in an RS 485 bus.....	6
5.4	4-wire connection in an RS-485 bus	7
5.5	RS-232 connector on the MCU	8
5.6	Power supply.....	8
6	Device descriptions	9
6.1	MCU	9
6.1.1	RS-485 port and power supply.....	10
6.1.2	RS-232 port.....	11
6.1.3	Fiber connector.....	11
6.1.4	Jumpers on MCU	11
6.1.5	Terminators and biasing on an RS-485 bus	13
6.2	PFC and CCA	14
6.2.1	How to connect CCA to PFC	14
7	Modbus register map for NC-12 PFC	15
7.1	Modbus function 4	15
7.2	Modbus functions 6 and 3	17
7.2.1	Parameter value tables.....	18
7.3	Modbus settings in the PFC	21
8	Technical specifications.....	23
8.1	Safety	23
8.2	Environmental conditions	23
9	Pictures.....	24
10	Tables.....	24

NRC12
Modbus application
USER'S MANUAL

2 Glossary

PFC	Power Factor Controller, type NRC12.
MCU	Modbus Coupler Unit, RS-485 adapter for fiber or RS-232.
CCA	Controller Communication Adapter, fiber output module for PFC.
PSU	Power Supply Unit.
RS-232	Serial communication standard. Typically used in short distances. Used to connect a PC.
RS-485	Serial communication standard. Designed for longer distances and for noise environments (industrial use).
SCADA	Supervisory Control And Data Acquisition software is a control room software.
MG	Merlin Gerin

3 NRC12 Modbus in general

This manual describes Modbus feature of PFC and its installation and operation.

PFC has a remote control feature using serial communication. The communication port requires an external CCA module installed on the PFC. The CCA provides a fiber connection port. Remote control protocol is Modbus. PFC is a Modbus slave device. With additional MCUs, fiber port may be adapted to RS-485 bus for long distances or for bus architecture. With an MCU, PC's serial port can be adapted to RS-485 bus. The PC acts as master of the Modbus bus and it needs the necessary software to read PFC slaves. Typically SCADA systems are used to collect data and display it.

NRC12 Modbus application USER'S MANUAL

4 Entire system

In the following chapters there are two alternatives for connections between the MCU to PFC and the MCU to PC. The selection depends on distances between modules and the number of PFC in the system.

4.1 PFC to PC connection alternatives

The PFC always needs a CCA module, when a remote control is used. The CCA module has a dedicated connector on the PFC. The CCA and MCU have fiber connectors.

4.1.1 One PFC

A fiber is adapted to an RS-485 bus connecting the MCU module. Maximum length of the RS-485 bus is 1 km. Additional PFC modules can easily connected to bus. MCU 1 / PC adapts the RS-485 bus to the RS-232 port.

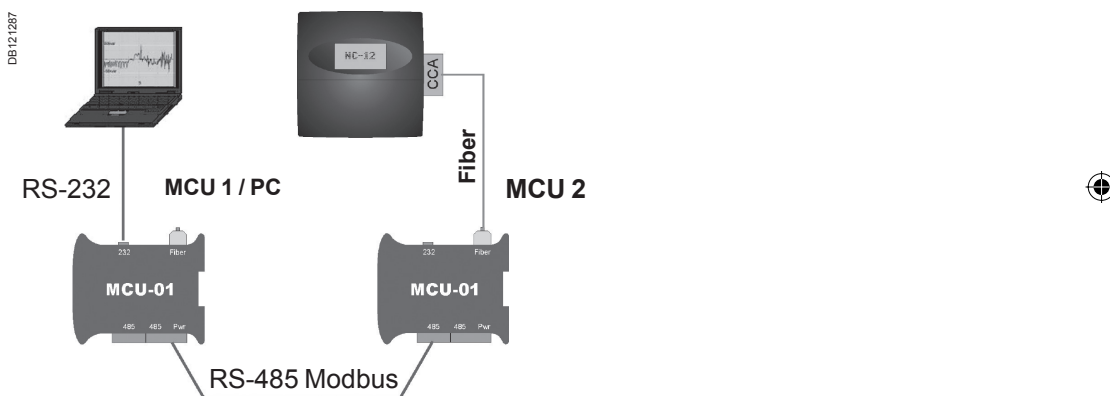

Picture 1: One PFC system

NRC12 Modbus application USER'S MANUAL

4.1.2 Many PFCs system

In the following picture there is a two PFC system. The same architecture is usable for 1 to 128 PFCs in the system.

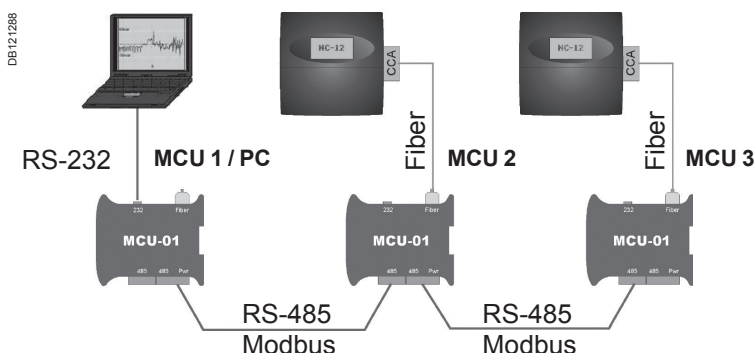

Picture 2: Two PFC in the system

5 Physical connections

All cables and connectors used are described in this chapter.

5.1 Fiber optic connection

The fiber optic cable is connected the CCA and the MCU. The fiber type used is 1 mm duplex POF (Polymer Optic Fiber) fiber or equivalent. Plugs on the fiber ends prevent the fiber from being wrongly connected. The fiber connection is so called crossover connection, where the transmitter (gray) is connected to the receiver (blue). Maximum length of the fiber is 30 m (90 ft). Minimum bending radius for this type fiber is 17 mm (0,67 in).

5.2 RS-485 interface

The PFC is connected to an RS-485 bus with an MCU module. All MCU-modules are connected in parallel to the bus and the PC acts as a bus master. A parallel connection means that the same pair of cables is connected to the same terminals in all modules. The bus master is connected using a crossover connection (transmitter to receiver pair). A crossover connection is used only in a 4-wire connection. RS-485 -connection is either a 2- or a 4-wire connection.

NRC12 Modbus application USER'S MANUAL

Modules are connected sequentially, branches on the cable are not allowed. The bus is terminated with terminator resistors. One terminator to each end of the bus. One module feeds biasing voltages to the bus. Each module is grounded via a PG (Protective Ground) terminal.

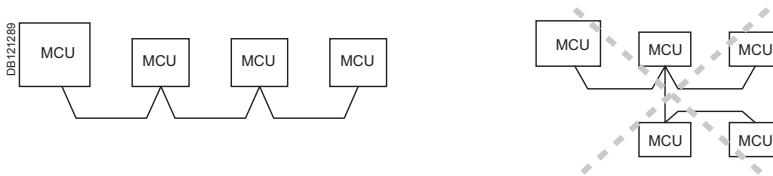

Picture 3: Correct structure of an RS-485 bus

5.3 2-wire connection in an RS 485 bus

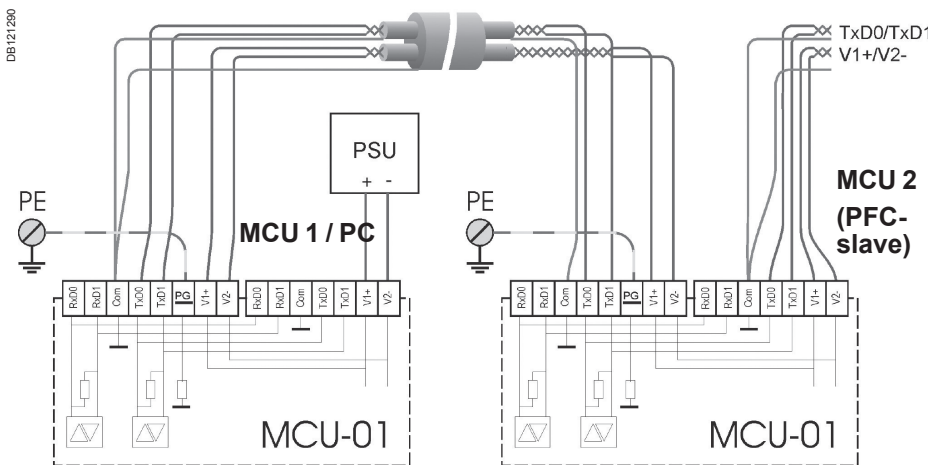

Picture 4: 2-wire connection in an RS-485 bus

Picture 4 describes connections in an RS-485 bus. Suitable cable types are e.g. Belden 3107A, 7201A, 9842 and Alpha Wire 6072C.

NRC12 Modbus application USER'S MANUAL

In following table all pins in the same row are connected together.

MCU #1 / PC	MCU #2	MCU #3	MCU #4	MCU #n
TxD0	TxD0	TxD0	TxD0	TxD0
TxD1	TxD1	TxD1	TxD1	TxD1
Common	Common	Common	Common	Common

Table 1: RS-485 bus connections using 2-wire cabling

Note: The PC can be placed in any position on RS-485 bus

5.4 4-wire connection in an RS-485 bus

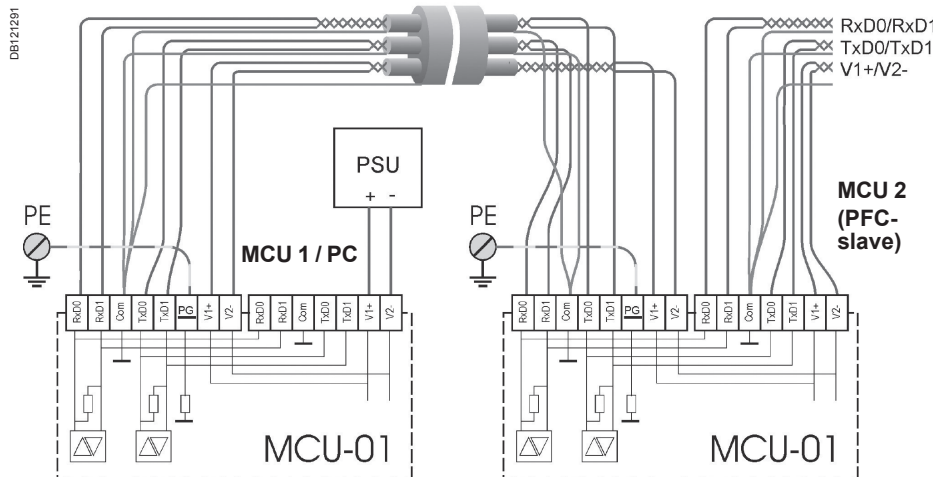

Picture 5: 4 wire connection in RS-485 bus

Picture 5 describes connections in RS-485 bus. Suitable cable types are e.g. Belden 3108A, 7202A, 9843 and Alpha Wire 6073C.

NRC12 Modbus application USER'S MANUAL

In the following table all pins in same row are connected together.

MCU #1 / Master	MCU #2 Slave	MCU #3 Slave	MCU #4 Slave	MCU #n Slave
TxD0	RxD0	RxD0	RxD0	RxD0
TxD1	RxD1	RxD1	RxD1	RxD1
Common	Common	Common	Common	Common
RxD0	TxD0	TxD0	TxD0	TxD0
RxD1	TxD1	TxD1	TxD1	TxD1

Table 2: RS-485 bus connections using 4-wire cabling

Note: The crossover connection between MCU #1 / PC and MCU #2 (PFC-slaves).

5.5 RS-232 connector on the MCU

Connector type is RJ-22 4P4C. Pin descriptions:

MCU pin	Id	Description	PC pin
1	TX	Transmit	2
2	GND	Ground	5
3	RX	Receiver	3
4	GND	Ground	5

Table 3: RS-232 cable between the MCU and PC

5.6 Power supply

The MCU has dedicated power supply pins on RS-485 connectors.

Voltage is +10...+30 V DC or 10...20 V AC.

Power consumption about 2 W / module.

The power supply can be common for all modules or every module may have its own power supply. Power from common supply is fed to modules using an extra pair of RS-485 cabling. Total power consumption depends on the power requirements of all modules plus power loss of cabling. A decrease in voltage with long cables must be taken into account. Power pins in the MCU are equipped with a rectifier. Neither pin is directly connected to the ground.

NRC12 Modbus application USER'S MANUAL

6 Device descriptions

6.1 MCU

The MCU has an RS-485 port (dual connectors A and B, for cascading purposes), fiber connectors and an RS-232 port. Used ports are selected with jumpers in an MCU. Bias voltages and bus terminators have their own DIP switches. In the front panel there is a power LED and status indication LEDs for communication. The MCU is DIN rail mountable.

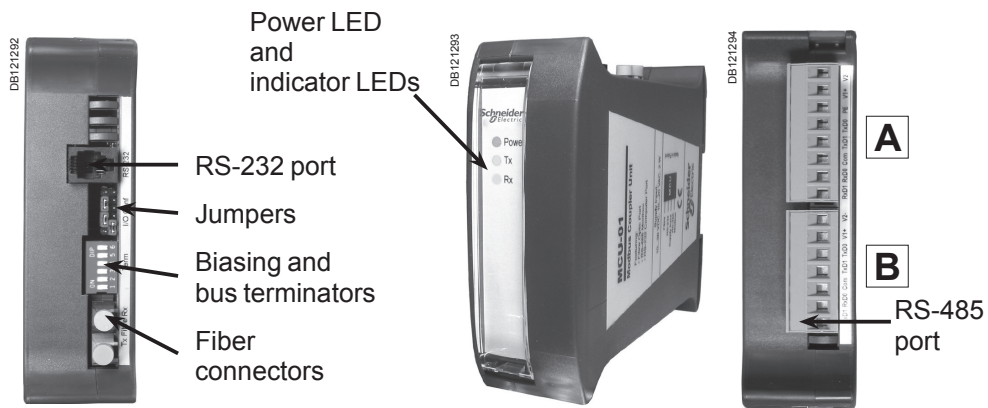

Picture 6: Connectors and indicators in MCU

NRC12

Modbus application

USER'S MANUAL

6.1.1 RS-485 port and power supply

Connector A: Connector type is Phoenix Contact MSTB 2,5/8-ST-5,08.

Pin	Id	Description
A1	RxD1	+ Rx RS-485 4-wire bus
A2	RxD0	- Rx RS-485 4-wire bus
A3	Common	Ground
A4	TxD1	+ Tx/Rx RS-485 2-wire bus
A5	TxD0	- Tx/Rx RS-485 2-wire bus
A6	PG	1 MΩ to ground. Protective ground.
A7	V1+	Power supply + 10 ... + 30 VDC or 10...20 VAC (2 W)
A8	V2-	Power supply

Table 4a: RS-485 port A pins

Connector B: For cascading purposes. It is connected parallel with connector A. Note the difference in pin count and order. Connector type is Phoenix Contact MSTB 2,5/7-ST-5,08.

Pin	Id	Description
B1	RxD1	+ Rx RS-485 4- wire bus
B2	RxD0	- Rx RS-485 4- wire bus
B3	Common	Ground
B4	TxD1	+ Tx/Rx RS-485 2- wire bus
B5	TxD0	- Tx/Rx RS-485 2- wire bus
B6	V1+	Power supply + 10 ... + 30 VDC or 10...20 VAC
B7	V2-	Power supply

Table 4b: RS-485 port B pins

NRC12 Modbus application USER'S MANUAL

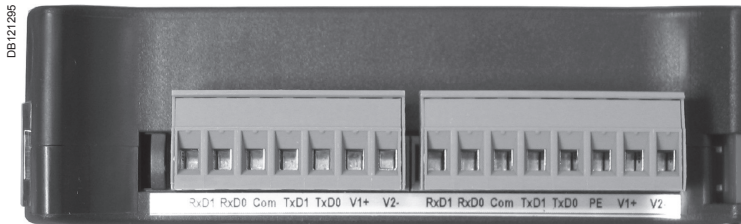

Picture 7: RS-485 pin numbers

6.1.2 RS-232 port

Connector type is RJ-22 4P4C.

Pin order:

Pin	Id	Description
1	TX	Transmit
2	GND	Ground
3	RX	Receive
4	GND	Ground

Table 5: RS-232 port pins

6.1.3 Fiber connector

Female fiber connector types are HFBR-1522 (transmit, gray) and HFBR-2522 (receiver, blue). Type of male plug is HFBR-4506. Fiber type is duplex 1 mm POF (Polymer Optic Fiber) fiber or equivalent.

6.1.4 Jumpers on MCU

The following table shows all the legal jumpering alternatives on an MCU.

NRC12
Modbus application
USER'S MANUAL

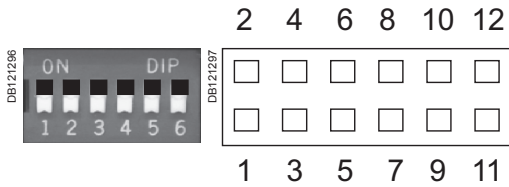

Picture 8: Jumpers on MCU

Modbus	PFC	Jumpers
RS-485 2-wire	Fiber	
RS-485 2-wire	RS-232	
RS-485 4-wire	Fiber	
RS-485 4-wire	RS-232	

Table 6: Jumpers on MCU

NRC12 Modbus application USER'S MANUAL

6.1.5 Terminators and biasing on an RS-485 bus

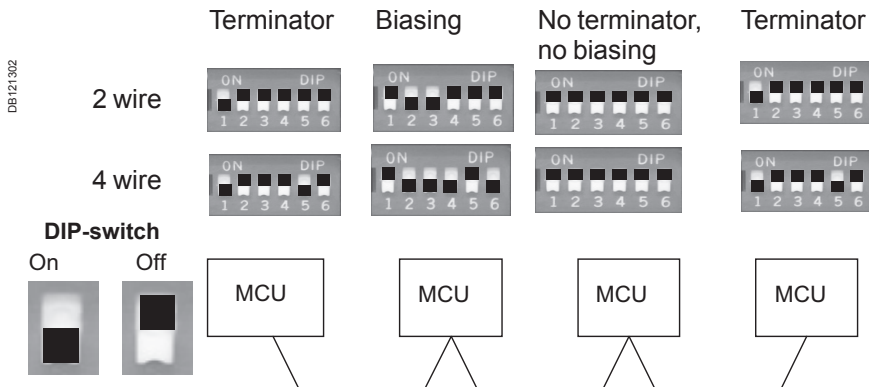

Picture 9: Terminators and biasing in RS-485 bus

Set the DIP switches according the picture above in MCU to connect terminators and biasing voltages to an RS-485 bus. Terminators are connected to both ends of the bus. Bias voltages are fed from only one device in the bus. When a 2-wire bus is used, terminators and biasing is needed only for the used pair.

Switch	Signal	Effect
DIP1	TxD	Terminator
DIP2	TxD0	- Bias voltage
DIP3	TxD1	+ Bias voltage
DIP4	RxD0	- Bias voltage
DIP5	RxD	Terminator
DIP6	RxD1	+ Bias voltage

Table 7: Terminators and biasing on an RS-485 bus

The termination of the line is done by a 120 ohm resistor. For biasing, two 620 ohm resistors are used.

NRC12 Modbus application USER'S MANUAL

6.2 PFC and CCA

A remote application needs a PFC and CCA. See manufacturer's manual for more information.

6.2.1 How to connect CCA to PFC

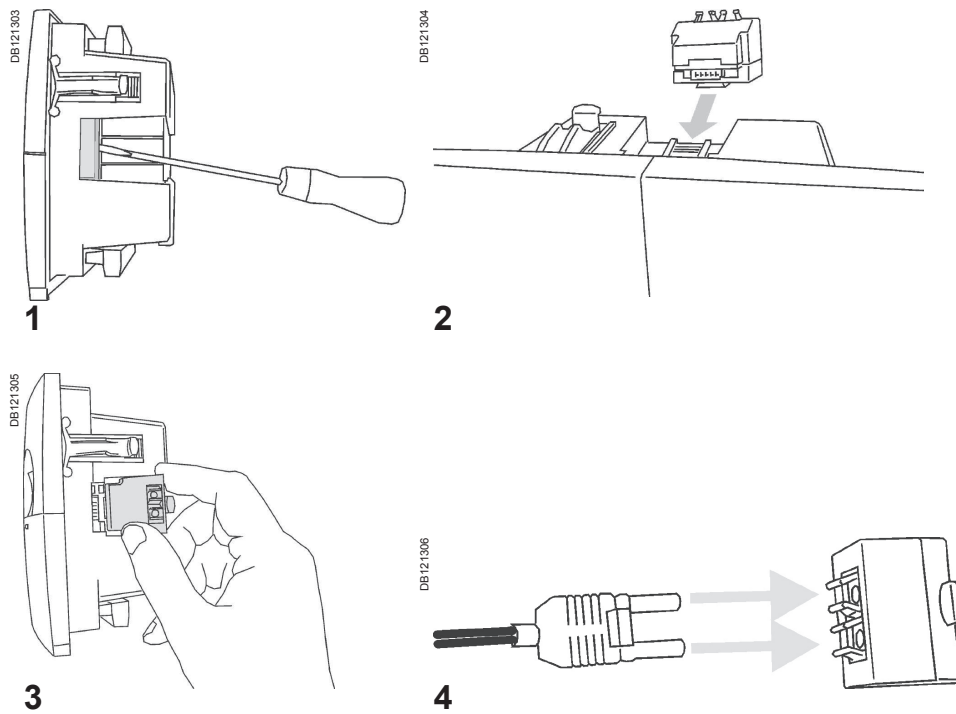

Picture 10: Installing procedure for CCA

1. Remove the cover of the connector
2. Slide the CCA into the connector track
3. Check that the CCA is properly installed
4. Remove the protect plugs and connect the fiber cable

NRC12
Modbus application
USER'S MANUAL

7 Modbus register map for NC-12 PFC

Only Modbus functions 3, 4 and 6 are implemented. Function 7 is not supported.

7.1 Modbus function 4

- 32-bit values reserve two consecutive registers.
- most significant part of 32-bit value is first register (lower index).
- 8-bit values are stored into 16-bit registers

Type	
S32	Signed 32-bit value
U32	Unsigned 32-bit value
S16	Signed 16-bit value
U16	Unsigned 16-bit value
S8	Sing-extended 8-bit value
U8	Unsigned 8-bit value

Table 8: Value types

Index	Name	Unit	Type
1	Active Power	W	S32
3	Reactive Power	var	S32
5	Apparent Power	VA	S32
7	Active Current	mA	S32
9	Reactive Current	mA	S32
11	Apparent current	mA	S32
13	Voltage	V	U32
15	Step 1: Number of connections		U32
17	Step 2: Number of connections		U32
19	Step 3: Number of connections		U32
21	Step 4: Number of connections		U32
23	Step 5: Number of connections		U32
25	Step 6: Number of connections		U32
27	Step 7: Number of connections		U32
29	Step 8: Number of connections		U32
31	Step 9: Number of connections		U32
33	Step 10: Number of connections		U32
35	Step 11: Number of connections		U32
37	Step 12 Number of connections		U32
39	Operation time of the regulator	h	U32
41	Serial Number		U32
43	Software version		U16
44	Voltage distortion	0.1%	U16
45	Cos ϕ : Pos=Ind, Neg=Cap 100=1.00	0.01	S16
46	Status of steps: bit/relay 1=ON		U16
47	Latched alarms (alarms in memory) bits in table 13		U16

NRC12
Modbus application
USER'S MANUAL

Index	Name	Unit	Type
48	Internal temperature	°C	S8
49	External temperature	°C	S8
50	Voltage harmonics 3rd	0.1%	U16
51	Voltage harmonics 5th	0.1%	U16
52	Voltage harmonics 7th	0.1%	U16
53	Voltage harmonics 9th	0.1%	U16
54	Voltage harmonics 11th	0.1%	U16
55	Voltage harmonics 13th	0.1%	U16
56	Voltage harmonics 15th	0.1%	U16
57	Voltage harmonics 17th	0.1%	U16
58	Voltage harmonics 19th	0.1%	U16
59	Voltage harmonics 21st	0.1%	U16
60	IRMS/I1	0.01%	U16
61	Broken status of steps: bit/relay 1=ON		U16
62	Active alarms: see table 13		U16
63	Alarm table, last alarm (alarm code, 0=no alarm)		U8
64	Alarm table, 2nd alarm in alarm log		U8
65	Alarm table, 3rd alarm in alarm log		U8
66	Alarm table, 4th alarm in alarm log		U8
67	Alarm table, 5th (earliest) alarm		U8
68	Detected frequency 1=50Hz, 2=60Hz		U8
69	Cos ϕ sign: Flow of power 0=Direct, -1=Reverse (generator)		S8
70	Status of fan relay 1=ON 0=OFF		U8

Table 9: Modbus registers, function 4

NRC12
Modbus application
USER'S MANUAL

7.2 Modbus functions 6 and 3

Number	Name	Unit	MIN	MAX	Type
1	Latched alarms (alarms in memory) bits in table 13		0	0	U16
2	Alarm mask. 1=enabled. See table 13 for special function.				U16 mask
3	Step shutdown mask of alarms. 1=enabled. See table 13 for special function.				U16 mask
4	Temperature limit (temperature alarm)	°C	20	60	U8
5	Fan offset limit	°C	0	50	U8
6	Voltage distortion limit (Alarm 10)	0.01%	50	200	U16
7	Irms/I1 limit	0.01	100	150	U16
8	Application 1=2Q 2=4Q		1	2	U8
9	Current transformer: If secondary 1A, primary*5	A	25	30000	U16
10	Input voltage	V	80	800	U16
11	Wiring, see table 14		1	54	U8
12	Target cos φ 1: 100=1.00	0.01	80	100	U8
13	Target cos φ 1 sign: 0=ind, -1=cap		-1	0	S8
14	Target cos φ 2: 100=1.00	0.01	80	100	U8
15	Target cos φ 2 sign: 0=ind, -1=cap		-1	0	S8
16	Inductive response value	0.01	1	199	U16
17	Capacitive response value	0.01	1	199	U16
18	Reconnection delay	s	10	900	U16
19	Step program: see table 12		1	5	U8
20	Number of steps		1	12	U8
21	Step sequence: see table 11		1	10	U8
22	Step size monitoring: step 1	kvar	0	400	U16
23	step 2	kvar	0	400	U16
24	step 3	kvar	0	400	U16
25	step 4	kvar	0	400	U16
26	step 5	kvar	0	400	U16
27	step 6	kvar	0	400	U16
28	step 7	kvar	0	400	U16
29	step 8	kvar	0	400	U16
30	step 9	kvar	0	400	U16
31	step 10	kvar	0	400	U16
32	step 11	kvar	0	400	U16
33	step 12	kvar	0	400	U16
34	Step size monitoring: nominal voltage of steps (phase to phase voltage)	V	200	800	U16
35	Current transformer, secondary current 1=1A,2=5A	A	1	2	U8

Table 10: Modbus registers for function 3 and 6

NRC12
Modbus application
USER'S MANUAL

7.2.1 Parameter value tables

Value	Step sequences
1	1.1.1.1.1.1.
2	1.1.2.2.2.2.
3	1.1.2.3.3.3.
4	1.1.2.4.4.4.
5	1.2.2.2.2.2.
6	1.2.3.3.3.3.
7	1.2.3.4.4.4.
8	1.2.3.6.6.6.
9	1.2.4.4.4.4.
10	1.2.4.8.8.8.

Table 11: Step sequences

Number	Step programs	Allowed sequences
1	NORMAL	SEQ 1.2.4.
2	CIRCULAR 1.1.1	SEQ 1.1.1.
3	CIRCULAR 1.2.2	SEQ 1.1.2.
4	STACK	SEQ 1.1.1.
5	OPTIMAL	All sequences

Table 12: Stepping programs

NRC12 Modbus application USER'S MANUAL

Alarm, alarm mask & shut down mask bit	PFC alarm	Step shut down mask effect	
		Read	Write
1	9	as set	1 / 0
2	10	as set	1 / 0
3	11	1	not changed
4	12	0	not changed
5	- (*)	0	not changed
6	- (*)	0	not changed
7	- (*)	0	not changed
8	- (*)	0	not changed
9	1	0	not changed
10	2	as set	1 / 0
11	3	0	not changed
12	4	1	not changed
13	5	0	not changed
14	6	0	not changed
15	7	0	not changed
16	8	1	not changed

(*) Always 0 when read

Table 13: Alarm bits

Wiring	Current measured	Voltage measuring	Current measuring polarity
1	L1	L2-L3	direct
2	L1	L3-L1	direct
3	L1	L1-L2	direct
4	L1	L1-N	direct
5	L1	L2-N	direct
6	L1	L3-N	direct
7	L1	L2-L3	reverse
8	L1	L3-L1	reverse
9	L1	L1-L2	reverse
10	L1	L1-N	reverse
11	L1	L2-N	reverse
12	L1	L3-N	reverse
13	L1	L2-L3	auto detection
14	L1	L3-L1	auto detection
15	L1	L1-L2	auto detection
16	L1	L1-N	auto detection
17	L1	L2-N	auto detection
18	L1	L3-N	auto detection
19	L2	L2-L3	direct
20	L2	L3-L1	direct
21	L2	L1-L2	direct

NRC12
Modbus application
USER'S MANUAL

Wiring	Current measured	Voltage measuring	Current measuring polarity
22	L2	L1-N	direct
23	L2	L2-N	direct
24	L2	L3-N	direct
25	L2	L2-L3	reverse
26	L2	L3-L1	reverse
27	L2	L1-L2	reverse
28	L2	L1-N	reverse
29	L2	L2-N	reverse
30	L2	L3-N	reverse
31	L2	L2-L3	auto detection
32	L2	L3-L1	auto detection
33	L2	L1-L2	auto detection
34	L2	L1-N	auto detection
35	L2	L2-N	auto detection
36	L2	L3-N	auto detection
37	L3	L2-L3	direct
38	L3	L3-L1	direct
39	L3	L1-L2	direct
40	L3	L1-N	direct
41	L3	L2-N	direct
42	L3	L3-N	direct
43	L3	L2-L3	reverse
44	L3	L3-L1	reverse
45	L3	L1-L2	reverse
46	L3	L1-N	reverse
47	L3	L2-N	reverse
48	L3	L3-N	reverse
49	L3	L2-L3	auto detection
50	L3	L3-L1	auto detection
51	L3	L1-L2	auto detection
52	L3	L1-N	auto detection
53	L3	L2-N	auto detection
54	L3	L3-N	auto detection

Table 14: Wiring

NRC12
Modbus application
USER'S MANUAL

7.3 Modbus settings in the PFC

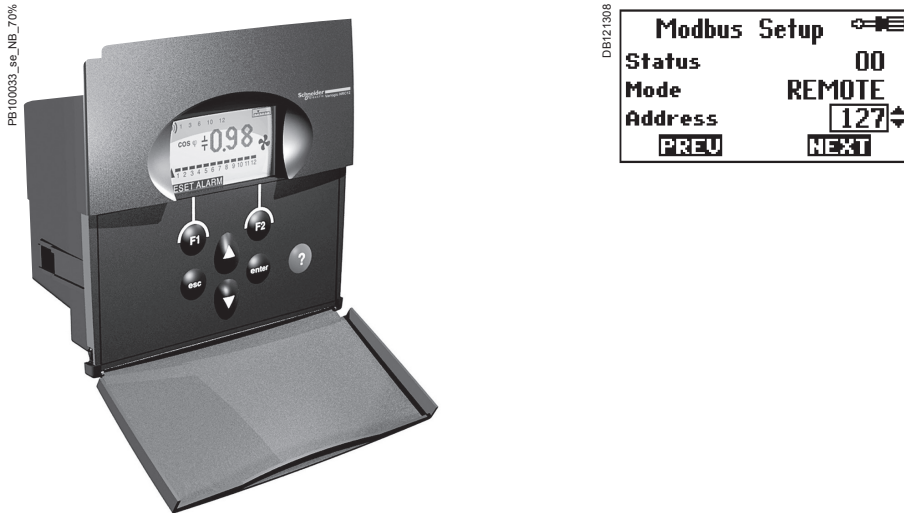

Picture 11: Modbus settings in the PFC

Required settings for the PFC are mode, Modbus address and baud rate.

NRC12 Modbus application USER'S MANUAL

Menu structure

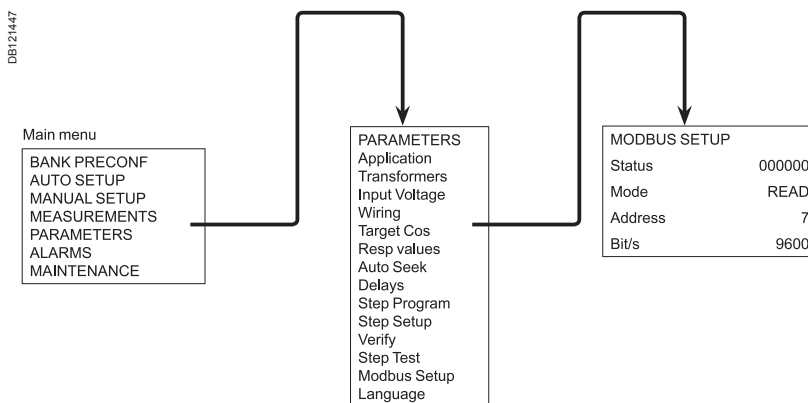

Picture 12: Menu structure of the PFC

Select PARAMETERS from the main menu. Access to the parameters menu is locked. To unlock the parameter menu, press both arrow keys simultaneously for 2 secs. Then select MODBUS SETUP. See PFC's manual for detailed instructions.

Modbus setup has the following parameters:

Status (not for set)	2 digits for correct frame counter + 2 digits for error counter + 2 digits for answer counter
Mode	The use of PFC's communication: NONE = Communication disabled READ = Communication is read only READ/RESET = Communication is read only with the exception that resetting of alarms is allowed.. READ/WRITE = Both read and write are allowed.
Address	Modbus address of PFC. Value between 1.....247
Bit/s	Communication baud rate (1200 ... 38400 bit/s). Even parity is used.

Table 15: Modbus parameters in PFC

For more information, see PFC's manual.



NRC12
Modbus application
USER'S MANUAL

8 Technical specifications

8.1 Safety

The following precautions must be taken into account when installing the system.

- The installation of the system must be done by a qualified electrician.
- Ensure that power supply is switched off before touching any parts in the system. Do not touch the connectors when the system is energized.
- Do not open the modules, there are no user serviceable parts inside.

8.2 Environmental conditions

The modules of the system are designed for the following environmental conditions:

- Indoor use
 - Altitude up to 2000 m
 - Ambient temperature within -10° ... $+60^{\circ}\text{C}$
 - Maximum relative humidity 95% for temperatures up to $+40^{\circ}\text{C}$
 - Category IP 20.
- 



NRC12
Modbus application
USER'S MANUAL

9 Pictures

Picture 1: One PFC system	4
Picture 2: Two PFC in the system	5
Picture 3: Correct structure of an RS-485 bus	6
Picture 4: 2-wire connection in an RS-485 bus	6
Picture 5: 4 wire connection in RS-485 bus	7
Picture 6: Connectors and indicators in MCU	9
Picture 7: RS-485 pin numbers	11
Picture 8: Jumpers on MCU	12
Picture 9: Terminators and biasing in RS-485 bus	13
Picture 10: Installing procedure for CCA	14
Picture 11: Modbus settings in the PFC	21
Picture 12: Menu structure of the PFC	22

10 Tables

Table 1: RS-485 bus connections using 2-wire cabling	7
Table 2: RS-485 bus connections using 4-wire cabling	8
Table 3: RS-232 cable between the MCU and PC	8
Table 4a: RS-485 port A pins	10
Table 4b: RS-485 port B pins	10
Table 5: RS-232 port pins	11
Table 6: Jumpers on MCU	12
Table 7: Terminators and biasing on an RS-485 bus	13
Table 8: Value types	15
Table 9: Modbus registers, function 4	16
Table 10: Modbus registers for function 3 and 6	18
Table 11: Step sequences	18
Table 12: Stepping programs	18
Table 13: Alarm bits	19
Table 14: Wiring	20
Table 15: Modbus parameters in PFC	22

Schneider Electric Industries SAS

Rectiphase
399 rue de la Gare
74370 Pringy
France
Tel. : 33 (0)4 50 66 95 00
Fax : 33 (0)4 50 27 24 19
<http://www.schneider-electric.com>
<http://www.merlin-gerin.com>

N° 3653572EN_AB

As standards, specifications and designs change from time to time, please ask for confirmation of the information given in this publication.

Printed on ecological paper
Layout: Schneider Electric - Sedoc
Photos: Schneider Electric
Printing:

© 2009 - Schneider Electric - All rights reserved
03-2009