

Quattro 650H/HS

Four-axis parallel robot achieves high speed and high precision

- Ethernet capability to control the robot through the familiar programming language (IEC 61131-3) of Machine Automation controller NJ/NX series
- Four-axis arm evenly distributes the load on the robot
- Fast and high-precision conveyance and assembly
- Designed with a high payload to support multi-hand (multi-picking)
- Supports fast Pick & Place on a fast conveyor
- Meets the sanitary standards of the United States Department of Agriculture for prevention of product contamination
- Maximum working diameter 1,300 mm
- Working height 500 mm
- Maximum payload 15 kg
- Weight 117 kg
- Protection IP66 (HS type)



Specifications

Product name		Quattro	
		650	
Size		H	HS
Type		1720□-2600□	1720□-2601□
Model		1720□-2600□	1720□-2601□
Number of axes		4	4
Mounting		inverted	
Working volume	X,Y axis (stroke)	1300 mm	
	Z axis (stroke)	500 mm	
	theta axis (rotation angle)	0° (fixed) (P30)	
		±46.25° (P31)	
±92.5° (P32)			
		±185° (P34)	
Maximum Payload		6 kg (P30: 15kg)	
Repeatability		±0.10mm	
Cycle times, sustained (at 20°C ambient)	Payload 0.1 kg	0.30s *1, 0.46 s *2	
	Payload 1.0 kg	0.36s *1, 0.47 s *2	
	Payload 2.0 kg	0.37s *1, 0.52 s *2	
	Payload 4.0 kg	0.41s *1, 0.58 s *2	
	Payload 6.0 kg	0.43s *1, 0.61 s *2	
Power Requirements		24 VDC: 11 A (eAIB, SmartController) 200 to 240 VAC: 10 A, single-phase	
Protection	Base	IP65 (with optional cable sealing kit)	IP66
	Tooling	IP67	IP67
Environment Requirements	Ambient Temperature	1 to 40°C	
	Humidity Range	5 to 90% (non-condensing)	
Weight		117 kg	
USDA-Accepted for meat and poultry processing		---	Yes
Basic configuration	Controller	SmartController EX	
	On-board I/O (Input/Output)	12/8	
	Conveyor tracking input	4	
	RS-232C serial communications port	1	
	Programming environment	ACE, PackXpert, PLC	
	ePLC Connect	Yes	
	ePLC I/O	Yes	
Connectable controller *3		SmartController EX, NJ/NX Series *4	

*1. Adept cycle, in mm (25/305/25)

*2. Extended cycle, in mm (25/700/25)

*3. Choose a controller to suit your application.

*4. The robot version 2.3.C is required to connect with the NX/NJ Series.

Dimensions

(Unit: mm)

Quattro 650H/HS

Note: The figure shows the HS type.

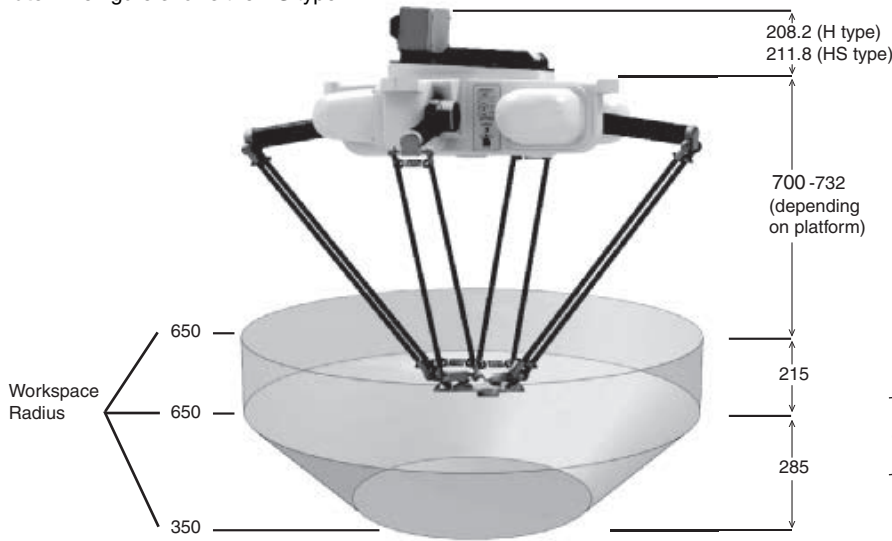



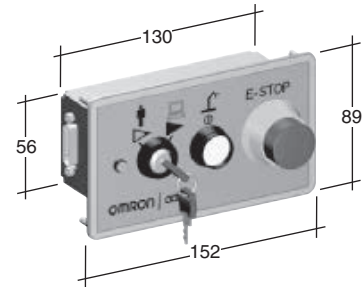

Front panel



SmartController EX



Four choices of platform offer different ranges of rotation.

Appearance				
Type	P30	P31	P32	P34
Rotation angle	No rotation	$\pm 46.25^\circ$	$\pm 92.5^\circ$	$\pm 185^\circ$
Maximum Payload	H: 15 Kg, HS: 12 Kg	H: 6 Kg, HS: 3 Kg	H: 6 Kg, HS: 3 Kg	H: 6 Kg, HS: 3 Kg

Note: The platform appearances of the H type are shown above. The platform of the HS type is made of stainless steel.

Robot Parts Code and Bundled Accessories

Type	Quattro with EX Controller	Quattro Add-On
Quattro 650H P30	17204-26000	17203-26000
Quattro 650H P31	17204-26001	17203-26001
Quattro 650H P32	17204-26002	17203-26002
Quattro 650H P34	17204-26004	17203-26004
Quattro 650HS P30	17204-26010	17203-26010
Quattro 650HS P31	17204-26011	17203-26011
Quattro 650HS P32	17204-26012	17203-26012
Quattro 650HS P34	17204-26014	17203-26014
Overview	Robot + eAIB+ SmartController EX + required connection cables	Robot + eAIB + required connection cables
Purpose	Typical for use in single robot system and multi-robot systems.	Typically added to systems with an existing SmartController EX to create multi-robot systems
Bundled Accessories	<ul style="list-style-type: none"> • XSYS cable with jumpers, 2m/6ft (13323-000) • SmartController EX (09200-000) • XSYS cable, 5m/15 ft (11585-000) • 1394 latch cable, 5m/15 ft, 13632-045) • Front panel kit (90356-10358) • eV+ license to connect to controller (14529-103) 	<ul style="list-style-type: none"> • XSYS cable with jumpers, 2m/6ft (13323-000) • XSYS cable, 5m/15 ft (11585-000) • DB9 splitter (00411-000) • 1394 latch cable, 5m/15 ft, 13632-045) • eV+ license to connect to controller (14529-103)

Note: OMRON also provides other types of model. Ask your OMRON sales representative for details.

ALL DIMENSIONS SHOWN ARE IN MILLIMETERS.

To convert millimeters into inches, multiply by 0.03937. To convert grams into ounces, multiply by 0.03527.