



Fluid Sensors

Level sensors, pressure sensors,
flow sensors, temperature sensors

Product family overview

Level sensors	
LFP Cubic	B-22
LFP Inox	B-30
LFH	B-36
UP56	B-42
UP56 Pure	B-48
MHF15	B-52
LFV200	B-56
LFV300	B-66
LBV300	B-76
LBV301	B-86

Flow sensors	
FFU	C-98
Bulkscan® LMS511	C-106

Pressure sensors	
PBS	D-118
PBT	D-126
PFT	D-136
PHT	D-144
PET	D-152

Temperature sensors	
TBS	E-170
TBT	E-178
TCT	E-186
TSP	E-194
THTS	E-200
THTE	E-208
THTL	E-214

Application areas

Suitable for:



Explosion areas



Hygienic

Hygienic applications



Bulk solids



Liquids

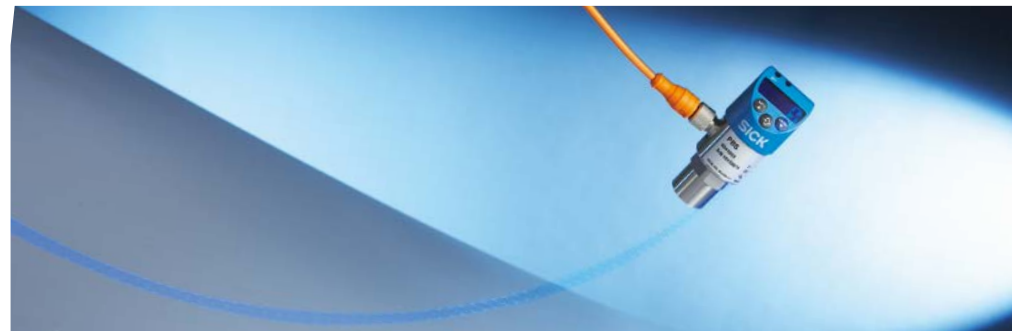

Fluid sensors in your E-Business Partner Portal.

www.mysick.com/products – order online directly

With this "Fluid Sensors" catalog, we present to you a compact selection of our product portfolio.

For much more information, including dimensional and CAD drawings, product information and operating instructions, go to the Product Finder at www.mysick.com/products and enter the part number, which you'll find on the product pages in the "Ordering information" table.

CAD drawings available free of charge

All current 2D and 3D CAD models for all products are available to download free of charge on our Partner Portal on the Internet.

- ▼ Fluid sensors
 - Level sensors
 - Flow sensors
 - Pressure sensors
 - Temperature sensors

The complete fluid sensor program with additional part numbers is available at www.mysick.com/products.

Info service

- Dimensional drawing
- Detection ranges
- CAD design models



More product information at

www.expert-level.com

Everything at a glance: You can find detailed information about our product portfolio under the "Products" and "Applications" menu items.

Your inquiry: Whether inquiries about applications or products – our sales staff is always available.



Level sensors

Intelligent solutions for level and point level measurement

Flow sensors









Rugged and accurate: Flow and throughput measurement with state-of-the-art technologies

Pressure sensors

Universal pressure measurement for liquids and gases

Temperature sensors

Reliable and accurate measurement of temperatures

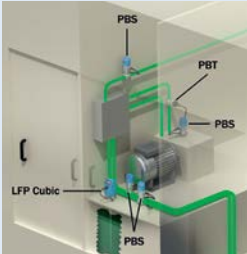
	General information About SICK	A
	 Level sensors LFP Cubic, LFP Inox, LFH, UP56, UP56 Pure, MHF15, LfV200, LfV300, LBV300, LBV301	B
	 Flow sensors FFU, Bulkscan® LMS511	C
	 Pressure sensors PBS, PBT, PFT, PHT, PET	D
	 Temperature sensors TBS, TBT, TCT, TSP, THTS, THTE, THTL	E
	 Appendix Glossary, Technologies and Topics	F

A

We deliver "Sensor Intelligence."

SICK sensor solutions for industrial automation are the result of exceptional dedication and experience. From development all the way to service: The people at SICK are committed to investing all their expertise in providing with the very best sensors and system solutions possible.

A company with a culture of success

Over 5,800 people are on staff, with products and services available to help SICK sensor technology users increase their productivity and reduce their costs. Founded in 1946 and headquartered in Waldkirch, Germany, SICK is a global sensor specialist with nearly 50 subsidiaries and representations worldwide. Our exemplary corporate culture fosters an optimum

work-life balance, thus attracting the best employees from all over the world. SICK is one of the best employers – we have been among the winners of the prestigious German "Great Place to Work" award for many years in succession.



Innovation for the leading edge

SICK sensor systems simplify and optimize processes and allow for sustainable production. SICK operates at many research and development centers all over the world. Co-designed with customers and universities, our innovative sensor products and solutions are made to give a decisive edge. With an impressive track record of innovation, we take the key parameters of modern production to new levels: reliable process control, safety of people and environmental protection.



A corporate culture for sustainable excellence

SICK is backed by a holistic, homogeneous corporate culture. We are an independent company. And our sensor technology is open to all system environments. The power of innovation has made SICK one of the technology and market leaders – sensor technology that is successful in the long term.



A "Sensor Intelligence." for all requirements

SICK is a renowned expert in many industries, and is entirely familiar with the critical challenges they face. While speed, accuracy and availability take center stage in all industries, technical implementations vary greatly. SICK puts its vast experience to use to provide with precisely the solution you need.

For applications worldwide

Hundreds of thousands of installations and applications go to prove that SICK knows the different industries and their processes inside out. This tradition of uncompromising expertise is ongoing: As we move into the future, we will continue to design,

implement and optimize customized solutions in our application centers in Europe, Asia and North America. You can count on SICK as a reliable supplier and development partner.



For your specific industry

With a track record of proven expertise in a great variety of industries, SICK has taken quality and productivity to new heights. The automotive, pharmaceutical, electronics and solar industries are just a few examples of sectors that benefit from our know-how. In addition to increasing speed and improving traceability in warehouses and distribution centers, SICK solutions provide accident protection for automated guided vehicles. SICK system solutions for analysis and flow measurement of gases and liquids enable environmental protection and sustainability in, for example, energy production, cement production or waste incineration plants.

For performance across the board

SICK provides the right technology to respond to the tasks involved in industrial automation: measuring, detecting, monitoring and controlling, protecting, networking and integrating, identifying, positioning. Our development and industry experts continually create groundbreaking innovations to solve these tasks.

www.sick.com/industries



A

For safety and productivity: SICK LifeTime Services

SICK LifeTime Services is a comprehensive set of high-quality services provided to support the entire life cycle of products and applications from plant walk-through all the way to upgrades. These services increase the safety of people, boost the productivity of machines and serve as the basis for our customers' sustainable business success.



The benefit of SICK services

Each of our products and solutions is accompanied by a comprehensive range of services tuned precisely to the requirements of the product or solution – along its entire life cycle. Backed by extensive industry expertise and more than 60 years

of experience, LifeTime Services stand for maximum availability and an exceptional service life of our products and solutions.





Consulting & Design

- Plant walk-through
- Risk assessment
- Safety concept
- Feasibility studies
- Software and hardware design



Verification & Optimization

- Inspection
- Maintenance
- Barcode checks
- Accident investigation
- Stoptime measurement
- Machine safety inspection



Training & Education

- User training
- Seminars
- WebTraining



Product & System Support

- Commissioning
- Exchange units and repairs
- Remote support
- Hotline



Upgrade & Retrofits

- Machine conversion
- Sensor upgrades
- Retrofitting of technology

www.sick.com/services

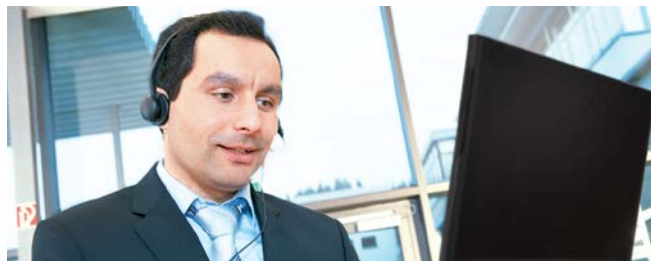

A Versatile product range for industrial automation

From the simple acquisition task to the key sensor technology in a complex production process: With every product from its broad portfolio, SICK offers a sensor solution that best combines cost effectiveness and safety.

www.sick.com/products

Photoelectric sensors



- Miniature photoelectric sensors
- Small photoelectric sensors
- Compact photoelectric sensors
- Fiber-optic sensors and fibers
- Cylindrical photoelectric sensors
- MutliTask photoelectric sensors

Proximity sensors



- Inductive proximity sensors
- Capacitive proximity sensors
- Magnetic proximity sensors

Magnetic cylinder sensors



- Analog positioning sensors
- Sensors for T-slot cylinders
- Sensors for C-slot cylinders
- Sensor adapters for other cylinder types

Identification solutions



- Bar code scanners
- Image-based code readers
- Hand-held scanners
- RFID

Detection and ranging solutions



- Laser measurement technology

System solutions



- Volume measurement systems
- Code reading systems
- Dimension weighing scanning systems
- Vision systems

Fluid sensors



- Level sensors
- Pressure sensors
- Flow sensors
- Temperature sensors

Registration sensors



- Contrast sensors
- Color sensors
- Luminescence sensors
- Fork sensors
- Array sensors
- Register sensors
- Markless sensors

Distance sensors



- Short range distance sensors (displacement)
- Mid range distance sensors
- Long range distance sensors
- Linear measurement sensors
- Ultrasonic sensors
- Double sheet detector
- Optical data transmission
- Position finders

A

Automation light grids



- Advanced automation light grids
- Standard automation light grids
- Smart light grids

Vision



- Vision sensors
- Smart cameras
- 3D cameras

Opto-electronic protective devices



- Safety laser scanners
- Safety camera systems
- Safety light curtains
- Multiple light beam safety devices
- Single-beam photoelectric safety switches
- Mirror and device columns
- Upgrade kits

Safety switches



- Electro-mechanical safety switches
- Non-contact safety switches
- Safety command devices

sens:Control – safe control solutions



- Safety relays
- Safety controllers
- Network solutions

Motor feedback systems



- Interfaces: incremental, HIPERFACE® and HIPERFACE DSL®
- Safety motor feedback systems
- Rotary and linear motor feedback systems for asynchronous, synchronous motors and linear motors

Encoders



- Absolute encoders
- Incremental encoders
- Linear encoders
- Wire draw encoders

Analyzers and systems



- Gas analyzers
- Dust measuring devices
- Analyzer systems
- Liquid analyzers
- Data acquisition systems
- Tunnel sensors

Gas flow measuring devices



- Gas flow meters
- Mass flow meters
- Volume flow measuring devices

Software



- Safexpert® safety software

Intelligent solutions for level and point level measurement

Whether for continuous level measurement, point level measurement or both – SICK offers a wide range of solutions for process engineering, storage and protection. Depending on the installation, characteristics of the liquid or solid, and ambient conditions, SICK provides a comprehensive product portfolio and a high level of expertise for more efficient processing.











Your benefits

- Robust sensors reduce downtimes
- Easy installation and mounting design through application-driven device concepts
- Maintenance-free sensors reduce total cost of ownership
- Easy integration into your system saves time
- Several outputs integrated into one device reduces cost
- High investment security thanks to innovative technologies that can also be used after system changes without calibration.
- Easy installation due to small housing size



B

Level sensors

<p>General information B-14</p> <p>Product family overview B-18</p>	
 <p>LFP Cubic B-22 Flexible up to the probe tip</p>	 <p>MHF15. B-52 Simple, compact and robust</p>
 <p>LFP Inox B-30 The clean solution</p>	 <p>LFV200 B-56 The point level sensor for all kinds of liquids</p>
 <p>LFH. B-36 At a high level</p>	 <p>LFV300 B-66 Flexible and robust in all kinds of liquids</p>
 <p>UP56. B-42 Tough, non-contact, pressure-resistant</p>	 <p>LBV300 B-76 Tough and flexible in bulk solids</p>
 <p>UP56 Pure. B-48 Pure reliability</p>	 <p>LBV301 B-86 Rugged, flexible and cleanable</p>



B

Efficient level and point level measurement technology

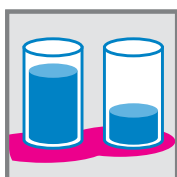

SICK's innovative offering includes guided radar sensors (TDR), ultrasonic equipment, vibration principle devices and various optical technologies. With SICK, the focus is on the optimum solution for your application. To do so, we offer a broad sensor portfolio.



Fast and reliable: continuous level detection



Liquids

Wherever precise level detection is needed at all times, continuous measurement principles such as TDR and ultrasonic are required. It is increasingly common for liquid processes to be measured exactly, to save resources and energy and to reduce costs. SICK provides industry-specific solutions that are ideal for this purpose.



Bulk materials

Continuous level measurement in the bulk materials segment is often challenging due to very difficult ambient conditions. Finding the optimum solution requires both appropriate technology and the expertise to help you find the right solution.



B

Point level measurement: simple and reliable switching



Liquids

If you need to find a simple and quick solution for point level applications for liquids, we can demonstrate our strengths to you. Whether you need to mount a sensor on a vertical surface or from above: SICK offers the right solution for your application problem. Our point level technology is maintenance-free with a long service life. We combine this with simple installation and commissioning so that you can benefit from efficient, maintenance-free solutions.



Bulk materials

To meet the demand for reliable point level sensors in the bulk segment, SICK offers a comprehensive range of solutions. In addition to their adaptability to a wide range of different installation situations, the tough design of these sensors makes them ideal for use in harsh ambient conditions.



Reliable level measurement and point level detection

Level monitoring in storage containers of beverage filling plants



Level measurement with LFP Inox

LFP Inox detects the level of storage containers to maintain the correct supply to the filling machine. Besides the aseptic design, the most important feature of this solution is fast, precise measurement.

Benefits:

- Quick response time
- High reproducibility
- Hygienic design
- High IP 69K enclosure rating
- Simple installation

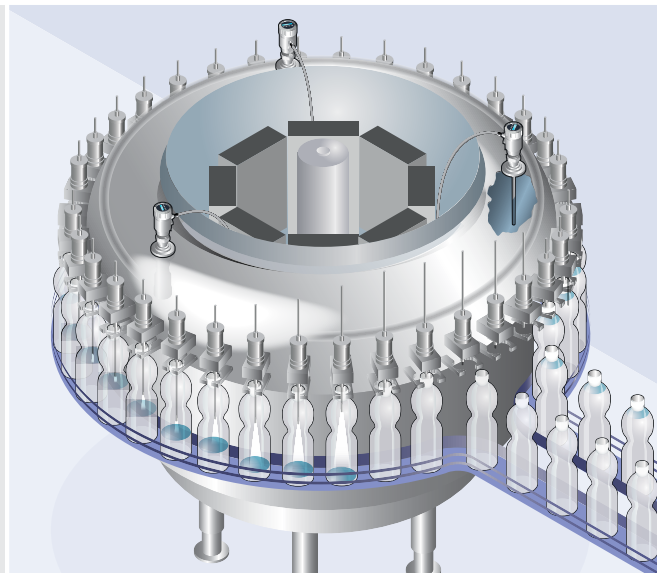

The LFP Inox emits a radar pulse, which is transmitted along the probe to the surface of the liquid. A level signal is generated using the time difference between the sent pulse and the echo.

Measurement of bulk materials in raw material silos

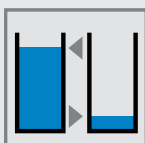

Point level measurement with LBV300

Level measurement and monitoring in raw material silos, such as overflow protection during filling or as a reliable minimum switch for emptying the silo. Rugged and universal measuring technology for almost every raw material.

Benefits:

- Tough design
- Simple commissioning
- No comparison of media required
- Flexible use



The sturdy stainless steel tuning fork is piezo-electrically energized and vibrates at its resonance frequency. If the tuning fork is covered with bulk material, the frequency changes. This is converted into a switch signal.

Efficient process control with state-of-the-art technologies

Point level measurement of fluid food and beverages



LFV200/230 "swings" in the tank. Once the tuning fork is covered with liquid, the resonance frequency changes. This change is reliably detected by the integrated electronic and converted into a switch signal.

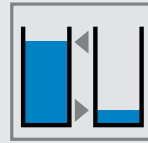

Point level measurement with LFV200/230

LFV200/230 is a universal sensor for the food and beverage industries that is used to monitor levels in storage and buffer tanks. It is also used for dry running pump protection. A compact design, high enclosure rating, CIP/SIP capability characterize this tuning fork for hygienic applications.

Benefits:

- Quick and easy commissioning
- Sensors can be tested without dismantling
- Flexible installation possibilities

B

Level measurement of aggressive liquids

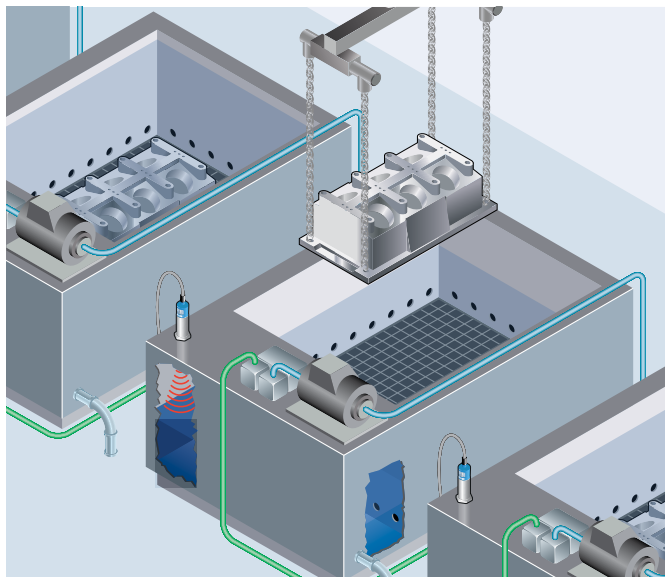

The UP56 emits an ultrasonic pulse. This is reflected by the filling substance. The UP56 uses the time difference between sending and receiving the sonic pulse to generate a level signal.

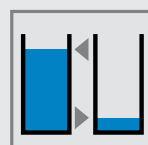





Level measurement with UP56

For level monitoring in small to medium-sized supply and buffer tanks with aggressive liquids, non-contact measuring technology is required. With its high-quality materials and high pressure resistance, the UP56 ultrasonic sensor is the ideal sensor for this application.



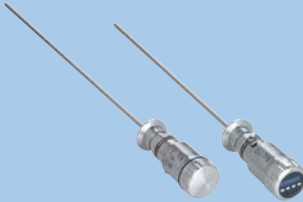



Benefits:

- Non-contact ultrasonic measuring technology
- High resistance due to Teflon-coated sensor
- Stainless steel or PVDF housing
- High pressure resistance of up to 6 bar





Product family overview

				
	LFP Cubic	LFP Inox	LFH	
	Flexible up to the probe tip	The clean solution	At a high level	
Technical data overview				
Measuring principle	TDR sensor	TDR sensor	Level probe	
Detection principle	Contact	Contact	Contact	
Medium	Fluids	Fluids	Fluids	
Measurement	Switch, continuous	Switch, continuous	Continuous	
At a glance				
				
	<ul style="list-style-type: none"> No mechanical moving parts Manually cuttable and exchangeable monoprobe with lengths from 200 mm up to 2,000 mm Immune to deposit formation Process temperature up to 100 °C; process pressure up to 10 bar Small inactive areas, ideal for small containers Accurate measurement, even when liquid type changes 3 in 1: combined display, analog output (acc. NAMUR NE 43) and binary output High enclosure rating of IP 67, rotatable housing 	<ul style="list-style-type: none"> Level monitoring in hygienic applications Manually cuttable monoprobe made from stainless steel 1.4404 up to 2,000 mm long with Ra ≤ 0.8 µm Process temperature up to 150 °C, process pressure up to 16 bar CIP/SIP resistant IP 67 and IP 69K enclosure rating Interchangeable hygienic process connections 3 in 1: combined display, analog output and binary output Analog output 4 mA ... 20 mA / 0 V ... 10 V, switchable, plus two binary outputs 	<ul style="list-style-type: none"> Immersion depth up to 100 m Available with various cable lengths Measuring ranges from 0 bar ... 0.1 bar up to 0 bar ... 25 bar Stainless steel membrane Hermetically sealed stainless steel housing with PA protection cap Cable made from PUR, FEP-cable for aggressive media optionally available Optional temperature measurement with integrated Pt100 element Optional surge protection 	
Detailed information	→ B-22	→ B-30	→ B-36	

B

 <p>UP56</p>	 <p>UP56 Pure</p>	 <p>MHF15</p>
<p>Tough, non-contact, pressure-resistant</p>	<p>Pure reliability</p>	<p>Simple, compact and robust</p>
<p>Ultrasonic sensor Non-contact Fluids, bulk solids Switch, continuous</p>	<p>Ultrasonic sensor Non-contact Fluids Switch, continuous</p>	<p>Optical level switch Contact Fluids Switch</p>
		
<ul style="list-style-type: none"> • Non-contact level measurement up to 3.4 m operating distance / 8.0 m limit scanning distance • Pressure resistant up to 6 bar (87 psi) • Transducer protected by PVDF cover for increased resistance • 3 in 1: continuous level measurement, level switch and display • Analog output switchable between 4 mA ... 20 mA and 0 V ... 10 V • Process connector thread G 1 and G 2 • IP 67 enclosure rating • Easy to set parameters, also via connect+ 	<ul style="list-style-type: none"> • Ultrasonic level sensor with very high chemical resistance • Non-contact measurement in immersion pipe of up to 1,500 mm • PTFE-coated membrane and GF D40 process connection made of PTFE • Pressure resistant up to 6 bar, temperature resistant up to 85 °C • Different sizes available • Analog output selectable between 4 mA ... 20 mA and 0 V ... 10 V • Switching output for monitoring the maximum and minimum limit 	<ul style="list-style-type: none"> • Robust level monitoring in liquid without additional requirements • Small, compact design; no medium calibration required • Process temperature up to 55 °C, process pressure up to 16 bar • IP 67 and IP 69K enclosure rating • Process connection G ½ • Highly medium resistant due to stainless steel housing 1.4404, polysulfone apex • Output available as PNP or NPN transistor • FDA-compliant, UL
<p>→ B-42</p>	<p>→ B-48</p>	<p>→ B-52</p>

Product family overview

	 <p style="text-align: center;">LFV200</p>	 <p style="text-align: center;">LFV300</p>	
<p style="text-align: center;">The point level sensor for all kinds of liquids</p>		<p style="text-align: center;">Flexible and robust in all kinds of liquids</p>	
<p>Technical data overview</p>			
<p>Measuring principle</p>	<p>Vibrating level switch</p>		<p>Vibrating level switch</p>
<p>Detection principle</p>	<p>Contact</p>		<p>Contact</p>
<p>Medium</p>	<p>Fluids</p>		<p>Fluids</p>
<p>Measurement</p>	<p>Switch</p>		<p>Switch</p>
<p>At a glance</p>			
	<div style="text-align: center;">  <p>Hygienic</p> </div> <ul style="list-style-type: none"> • Housing made of 316L stainless steel • Two electrical output versions available • Commissioning without filling • Process temperature up to 150 °C • Immune to deposit formation • Very high repeatability • Aseptic versions with polished surface, CIP and SIP resistant • Tube extension up to 6 m 		<div style="text-align: center;">  <p>Hygienic</p> </div> <ul style="list-style-type: none"> • Several housing materials and electrical outputs available • Commissioning without filling • Process temperature up to 250 °C • Immune to deposit formation • Very high repeatability • Aseptic versions according to EHEDG and FDA available, CIP and SIP resistant • ATEX certification available • Tube extension up to 6 m
<p>Detailed information</p>	<p style="text-align: center;">→ B-56</p>		<p style="text-align: center;">→ B-66</p>

B



LBV300

Tough and flexible in bulk solids



LBV301

Rugged, flexible and cleanable

Vibrating level switch

Contact

Bulk solids

Switch

Vibrating level switch

Contact

Bulk solids

Switch



- Tough device design
- Several housing materials and electrical outputs available
- Immune to deposit formation
- Commissioning without filling
- Process temperature up to 250 °C
- Very high repeatability
- ATEX versions (1D/2D/1G/2G) available
- Tube-extended version (LBV330) up to 6 m and rope-extended version (LBV320) up to 80 m available for vertical mounting

- Compact sensor from 1" thread
- Monoprobe design prevents bulk materials from sticking and jamming
- Polished monoprobe for food applications
- Commissioning without filling
- Process temperature up to 250 °C
- ATEX versions (1D/2D/1G/2G) available
- Tube-extended version (LBV331) up to 6 m and rope-extended version (LBV321) up to 80 m available for vertical mounting

→ B-76

→ B-86

B

Flexible up to the probe tip



Product description

The LFP Cubic is a level sensor that uses TDR technology (time domain reflectometry) and thus can be used in oil- and water-based liquids without calibration. The LFP's guided radar uses time-of-flight technology to measure electromagnetic pulses. The time difference between the sent pulse and the reflected pulse is used to calculate the level, both as a continuous value (analog output) and a freely positionable switching point (switching output). Due to

its flexible probe that can be changed or cut, it is possible to integrate the sensor quickly into any application. The LFP Cubic can work in deposit-forming and foaming liquids. The sensor's intuitive setup uses four buttons and a display to ensure quick and easy adaptation to the application. In addition to the discrete and analog output signals, an IO-Link interface is available to transmit additional valuable process data to the control unit.

At a glance

- No mechanical moving parts
- Manually cuttable and exchangeable monoprobe with lengths from 200 mm up to 2,000 mm
- Immune to deposit formation
- Process temperature up to 100 °C; process pressure up to 10 bar
- Small inactive areas, ideal for small containers
- Accurate measurement, even when liquid type changes
- 3 in 1: Combined display, analog output (acc. NAMUR NE 43) and binary output
- High enclosure rating of IP 67, rotatable housing

Your benefits

- Rugged design increases service life
- High flexibility due to cuttable and exchangeable monoprobe
- Cost savings due to multiple output signals: one system for both level detection and continuous level monitoring
- Time and cost savings due to low maintenance and quick commissioning
- No calibration or recalibration required for commissioning, thus saving time and costs
- Compact and rotatable housing ensures flexible installation
- No crosstalk when several sensors are mounted next to each other
- Advanced technology enables adjustment-free measurement of oil- and water-based liquids



Additional information

Detailed technical data.	B-23
Ordering information.	B-24
Type code.	B-26
Dimensional drawings	B-27
Recommended accessories.	B-27

→ www.mysick.com/en/LFP_Cubic

For more information, just enter the link or scan the QR code and get direct access to technical data, CAD design models, operating instructions, software, application examples and much more.



Detailed technical data

Features

Medium	Fluids
Measurement	Switch, continuous
Probe length	200 mm ... 2,000 mm
Process pressure	-1 bar ... 10 bar
Process temperature	-20 °C ... +100 °C
GOST approval	✓
RoHS certificate	✓
IO-Link	✓

Performance

Accuracy of sensor element ¹⁾	± 5 mm
Repeatability	≤ 2 mm
Resolution	< 2 mm
Response time ²⁾	< 400 ms
Dielectricity constant	≥ 5 for mono probe ≥ 1.8 with coaxial tube
Conductivity	No limitation
Maximum level change ³⁾	≤ 500 mm/s
Inactive area at process connector ⁴⁾	25 mm
Inactive area at probe end ¹⁾	10 mm

¹⁾ With water under reference conditions.

²⁾ Depending on the measurement mode (High-Speed < 400 ms, High Accuracy < 2,800 ms).

³⁾ Depending on the configuration (MaxCol – Maximum change of level).

⁴⁾ With parameterized tank with water under reference conditions, otherwise 40 mm.

Mechanics

Wetted parts	1.4404, PTFE
Process connection	See type code
Housing material	Plastic PBT
Max. probe load	≤ 6 Nm

Electronics

Supply voltage ¹⁾	12 V DC ... 30 V DC
Power consumption	≤ 100 mA at 24 V DC without output load
Initialization time	≤ 5 s
Protection class	III
Electrical connection	Round connector M12 x 1, 5-pin Round connector M12 x 1, 8-pin
Output signal	4 mA ... 20 mA, 0 V ... 10 V automatic switching depending on the load. ¹⁾ 1 PNP transistor output (Q1) and 1 PNP / NPN transistor output (Q2) switchable or 1 PNP transistor output (Q1) und 3 PNP / NPN transistor output (Q2...Q4) switchable (depending on type) ¹⁾
Output load	4 mA ... 20 mA < 500 Ohm at $V_S > 15 V$ 4 mA ... 20 mA < 350 Ohm at $V_S > 12 V$ 0 V ... 10 V > 750 Ohm at $V_S \geq 14 V$
Hysteresis	Min. 2 mm, free adjustable

¹⁾ All connections are polarity protected. All outputs are overload and short-circuit protected.

Signal voltage HIGH	$V_s - 2 \text{ V}$
Signal voltage LOW	$\leq 2 \text{ V}$
Output current	$< 100 \text{ mA}$
Inductive load	$< 1 \text{ H}$
Capacitive load	100 nF
Enclosure rating	IP 67: EN 60529
Temperature drift	$< 0.1 \text{ mm/K}$
Lower signal level	$3.8 \text{ mA} \dots 4 \text{ mA}$
Upper signal level	$20 \text{ mA} \dots 20.5 \text{ mA}$
EMC	EN 61326-1:2006, 2004/108/EG

¹⁾ All connections are polarity protected. All outputs are overload and short-circuit protected.

B

Ambient data

Ambient operating temperature	$-20 \text{ °C} \dots +60 \text{ °C}$
Ambient storage temperature	$-40 \text{ °C} \dots +80 \text{ °C}$

Ordering information

The part numbers below show a selection of our common configurations and represent only a portion of the product portfolio. The type code on page B-26 indicates all possible configurations that can be ordered.

- Enclosure rating: IP 67: EN 60529
- Process connection: $\frac{3}{4}$ " NPT
- Process temperature: $-20 \text{ °C} \dots +100 \text{ °C}$
- Process pressure: $-1 \text{ bar} \dots 10 \text{ bar}$
- Housing material: Plastic PBT

Output signal	Electrical connection	Probe length	Model name	Part no.
1 x PNP + 1 x PNP/NPN + 4 mA ... 20 mA / 0 V ... 10 V	Round connector M12 x 1, 5-pin	200 mm	LFP0200-B4NMB	1057092
		300 mm	LFP0300-B4NMB	1057093
		400 mm	LFP0400-B4NMB	1057094
		500 mm	LFP0500-B4NMB	1057095
		600 mm	LFP0600-B4NMB	1057096
		700 mm	LFP0700-B4NMB	1057097
		800 mm	LFP0800-B4NMB	1057098
		900 mm	LFP0900-B4NMB	1057099
		1,000 mm	LFP1000-B4NMB	1057100
		1,100 mm	LFP1100-B4NMB	1057101
		1,200 mm	LFP1200-B4NMB	1057102
		1,300 mm	LFP1300-B4NMB	1057103
		1,400 mm	LFP1400-B4NMB	1057104
		1,500 mm	LFP1500-B4NMB	1057105
		1,600 mm	LFP1600-B4NMB	1057106
		1,700 mm	LFP1700-B4NMB	1057107
		1,800 mm	LFP1800-B4NMB	1057108
1,900 mm	LFP1900-B4NMB	1057109		
2,000 mm	LFP2000-B4NMB	1057110		

Output signal	Electrical connection	Probe length	Model name	Part no.
1 x PNP + 3 x PNP/NPN + 4 mA ... 20 mA / 0 V ... 10 V	Round connector M12 x 1, 8-pin	200 mm	LFP0200-B5NMC	1062264
		300 mm	LFP0300-B4NMB	1062265
		400 mm	LFP0400-B5NMC	1062266
		500 mm	LFP0500-B5NMC	1062267
		600 mm	LFP0600-B5NMC	1062268
		700 mm	LFP0700-B5NMC	1062269
		800 mm	LFP0800-B5NMC	1062270
		900 mm	LFP0900-B5NMC	1062271
		1,000 mm	LFP1000-B5NMC	1062272
		1,100 mm	LFP1100-B5NMC	1062273
		1,200 mm	LFP1200-B5NMC	1062274
		1,300 mm	LFP1300-B5NMC	1062275
		1,400 mm	LFP1400-B5NMC	1062276
		1,500 mm	LFP1500-B5NMC	1062277
		1,600 mm	LFP1600-B5NMC	1062278
		1,700 mm	LFP1700-B5NMC	1062279
		1,800 mm	LFP1800-B5NMC	1062280
1,900 mm	LFP1900-B5NMC	1062281		
2,000 mm	LFP2000-B5NMC	1062282		

- **Enclosure rating:** IP 67: EN 60529
- **Process connection:** G $\frac{3}{4}$ A
- **Process temperature:** -20 °C ... +100 °C
- **Process pressure:** -1 bar ... 10 bar
- **Housing material:** Plastic PBT

Output signal	Electrical connection	Probe length	Model name	Part no.
1 x PNP + 1 x PNP/NPN + 4 mA ... 20 mA / 0 V ... 10 V	Round connector M12 x 1, 5-pin	200 mm	LFP0200-A4NMB	1057073
		300 mm	LFP0300-A4NMB	1057074
		400 mm	LFP0400-A4NMB	1057075
		500 mm	LFP0500-A4NMB	1057076
		600 mm	LFP0600-A4NMB	1057077
		700 mm	LFP0700-A4NMB	1057078
		800 mm	LFP0800-A4NMB	1057079
		900 mm	LFP0900-A4NMB	1057080
		1,000 mm	LFP1000-A4NMB	1057081
		1,100 mm	LFP1100-A4NMB	1057082
		1,200 mm	LFP1200-A4NMB	1057083
		1,300 mm	LFP1300-A4NMB	1057084
		1,400 mm	LFP1400-A4NMB	1057085
		1,500 mm	LFP1500-A4NMB	1057086
		1,600 mm	LFP1600-A4NMB	1057087
		1,700 mm	LFP1700-A4NMB	1057088
		1,800 mm	LFP1800-A4NMB	1057089
1,900 mm	LFP1900-A4NMB	1057090		
2,000 mm	LFP2000-A4NMB	1057091		

Dimensional drawings

dimensions in mm (inch)

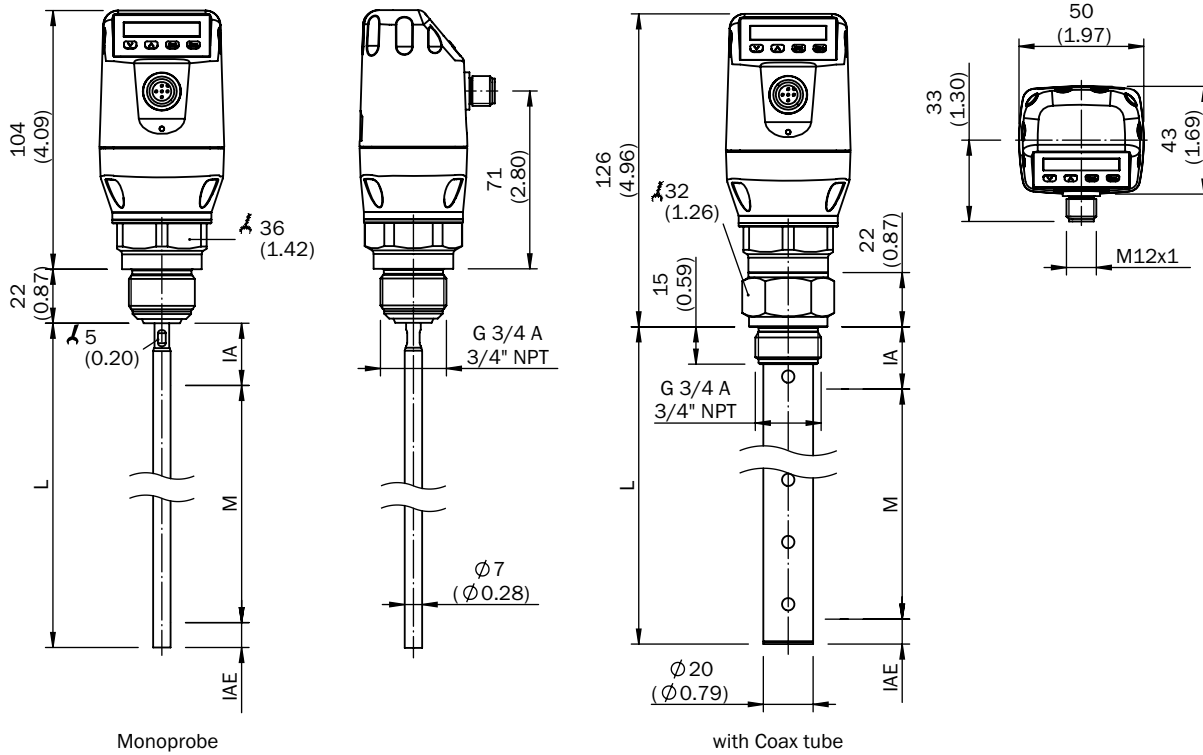

B

M: Measuring range
 L: Probe length
 IA: Inactive area at process connection 25 mm (0.98")
 IAE: Inactive area at probe end 10 mm (0.39")

Recommended accessories

Spare parts

	Brief description	Model name	Part no.
Illustration may differ	Spare probe for LFP Cubic, probe length 1,000 mm, material 1.4404/316L, diameter 7 mm	BEF-ER-SN1000-LFPc	2065700
	Spare probe for LFP Cubic, probe length 2,000 mm, material 1.4404/316L, diameter 7 mm	BEF-ER-SN2000-LFPC	2065701

Device protection (mechanical)

	Brief description	Model name	Part no.
Illustration may differ	Coaxial tube for LFP with process connection G 3/4, process connection of coaxial tube G 3/4, material 1.4571/316TI, for probe length 200 mm	LFPCT-0200G1	2068141
	Coaxial tube for LFP with process connection G 3/4, process connection of coaxial tube 3/4" NPT, material 1.4571/316TI, for probe length 200 mm	LFPCT-0200N1	2068165
	Coaxial tube for LFP with process connection G 3/4, process connection of coaxial tube G 3/4, material 1.4571/316TI, for probe length 300 mm	LFPCT-0300G1	2068142
	Coaxial tube for LFP with process connection G 3/4, process connection of coaxial tube 3/4" NPT, material 1.4571/316TI, for probe length 300 mm	LFPCT-0300N1	2068166
	Coaxial tube for LFP with process connection G 3/4, process connection of coaxial tube G 3/4, material 1.4571/316TI, for probe length 400 mm	LFPCT-0400G1	2068143
	Coaxial tube for LFP with process connection G 3/4, process connection of coaxial tube 3/4" NPT, material 1.4571/316TI, for probe length 400 mm	LFPCT-0400N1	2068167
	Coaxial tube for LFP with process connection G 3/4, process connection of coaxial tube G 3/4, material 1.4571/316TI, for probe length 500 mm	LFPCT-0500G1	2068144

B

	Brief description	Model name	Part no.
	Coaxial tube for LFP with process connection G 3/4, process connection of coaxial tube 3/4" NPT, material 1.4571/316TI, for probe length 500 mm	LFPCT-0500N1	2068168
	Coaxial tube for LFP with process connection G 3/4, process connection of coaxial tube G 3/4, material 1.4571/316TI, for probe length 600 mm	LFPCT-0600G1	2068145
	Coaxial tube for LFP with process connection G 3/4, process connection of coaxial tube 3/4" NPT, material 1.4571/316TI, for probe length 600 mm	LFPCT-0600N1	2068169
	Coaxial tube for LFP with process connection G 3/4, process connection of coaxial tube G 3/4, material 1.4571/316TI, for probe length 700 mm	LFPCT-0700G1	2068146
	Coaxial tube for LFP with process connection G 3/4, process connection of coaxial tube 3/4" NPT, material 1.4571/316TI, for probe length 700 mm	LFPCT-0700N1	2068170
	Coaxial tube for LFP with process connection G 3/4, process connection of coax probe G 3/4, material 1.4571/316TI, for probe length 800 mm	LFPCT-0800G1	2068147
	Coaxial tube for LFP with process connection G 3/4, process connection of coaxial tube 3/4" NPT, material 1.4571/316TI, for probe length 800 mm	LFPCT-0800N1	2068171
	Coaxial probe for LFP with process connection G 3/4, process connection of coaxial tube G 3/4, material 1.4571/316TI, for probe length 900 mm	LFPCT-0900G1	2067507
	Coaxial probe for LFP with process connection G 3/4, process connection of coaxial tube 3/4" NPT, material 1.4571/316TI, for probe length 900 mm	LFPCT-0900N1	2068172
	Coaxial probe for LFP with process connection G 3/4, process connection of coaxial tube G 3/4, material 1.4571/316TI, for probe length 1,000 mm	LFPCT-1000G1	2065702
	Coaxial tube for LFP with process connection G 3/4, process connection of coaxial tube 3/4" NPT, material 1.4571/316TI, for probe length 1,000 mm	LFPCT-1000N1	2068173
	Coaxial tube for LFP with process connection G 3/4, process connection of coaxial tube G 3/4, material 1.4571/316TI, for probe length 1,100 mm	LFPCT-1100G1	2068148
	Coaxial tube for LFP with process connection G 3/4, process connection of coaxial tube 3/4" NPT, material 1.4571/316TI, for probe length 1,100 mm	LFPCT-1100N1	2068174
	Coaxial tube for LFP with process connection G 3/4, process connection of coaxial tube G 3/4, material 1.4571/316TI, for probe length 1,200 mm	LFPCT-1200G1	2068149
	Coaxial tube for LFP with process connection G 3/4, process connection of coaxial tube 3/4" NPT, material 1.4571/316TI, for probe length 1,200 mm	LFPCT-1200N1	2068175
	Coaxial tube for LFP with process connection G 3/4, process connection of coaxial tube G 3/4, material 1.4571/316TI, for probe length 1,300 mm	LFPCT-1300G1	2068150
Illustration may differ	Coaxial tube for LFP with process connection G 3/4, process connection of coaxial tube 3/4" NPT, material 1.4571/316TI, for probe length 1,300 mm	LFPCT-1300N1	2068176
	Coaxial tube for LFP with process connection G 3/4, process connection of coaxial tube G 3/4, material 1.4571/316TI, for probe length 1,400 mm	LFPCT-1400G1	2068151
	Coaxial tube for LFP with process connection G 3/4, process connection of coaxial tube 3/4" NPT, material 1.4571/316TI, for probe length 1,400 mm	LFPCT-1400N1	2068177
	Coaxial tube for LFP with process connection G 3/4, process connection of coaxial tube G 3/4, material 1.4571/316TI, for probe length 1,500 mm	LFPCT-1500G1	2068152
	Coaxial tube for LFP with process connection G 3/4, process connection of coaxial tube 3/4" NPT, material 1.4571/316TI, for probe length 1,500 mm	LFPCT-1500N1	2068178
	Coaxial tube for LFP with process connection G 3/4, process connection of coaxial tube G 3/4, material 1.4571/316TI, for probe length 1,600 mm	LFPCT-1600G1	2068153
	Coaxial tube for LFP with process connection G 3/4, process connection of coaxial tube 3/4" NPT, material 1.4571/316TI, for probe length 1,600 mm	LFPCT-1600N1	2068179
	Coaxial tube for LFP with process connection G 3/4, process connection of coaxial tube G 3/4, material 1.4571/316TI, for probe length 1,700 mm	LFPCT-1700G1	2068154
	Coaxial tube for LFP with process connection G 3/4, process connection of coaxial tube 3/4" NPT, material 1.4571/316TI, for probe length 1,700 mm	LFPCT-1700N1	2068180
	Coaxial tube for LFP with process connection G 3/4, process connection of coaxial tube G 3/4, material 1.4571/316TI, for probe length 1,500 mm	LFPCT-1800G1	2068155
	Coaxial tube for LFP with process connection G 3/4, process connection of coaxial tube 3/4" NPT, material 1.4571/316TI, for probe length 1,800 mm	LFPCT-1800N1	2068181
	Coaxial tube for LFP with process connection G 3/4, process connection of coax probe G 3/4, material 1.4571/316TI, for probe length 1,900 mm	LFPCT-1900G1	2068156
	Coaxial tube for LFP with process connection G 3/4, process connection of coaxial tube 3/4" NPT, material 1.4571/316TI, for probe length 1,900 mm	LFPCT-1900N1	2068182
	Coaxial probe for LFP with process connection G 3/4, process connection of coaxial tube G 3/4, material 1.4571/316TI, for probe length 1,000 mm	LFPCT-2000G1	2065703
	Coaxial tube for LFP with process connection G 3/4, process connection of coaxial tube 3/4" NPT, material 1.4571/316TI, for probe length 2,000 mm	LFPCT-2000N1	2068183

Terminal and alignment brackets

	Brief description	Model name	Part no.
	Centering for bypass- and immersion tube installation with diameter 40 mm ... 100 mm	BEF-FL-BYRD40-LFP1	2059612

Others

	Brief description	Model name	Part no.
	IO-Link-Master	IOLSHPB-P3104R01	6039728

Plug connectors and cables

	Brief description	Model name	Part no.
 Illustration may differ	Cable, M12, 5-pin, straight connector female with molded cable, 2 m, PVC	DOL-1205-G02M	6008899
	Cable, M12, 5-pin, straight connector female with molded cable, 5 m, PVC	DOL-1205-G05M	6009868
	Cable, M12, 5-pin, straight connector female with molded cable, 10 m, PVC	DOL-1205-G10M	6010544
 Illustration may differ	Cable, M12, 5-pin, straight connector female with molded cable, 2 m, PUR halogen free	DOL-1205-G02MC	6025906
	Cable, M12, 5-pin, straight connector female with molded cable, 5 m, PUR halogen free	DOL-1205-G05MC	6025907
	Cable, M12, 5-pin, straight connector female with molded cable, 10 m, PUR halogen free	DOL-1205-G10MC	6025908
 Illustration may differ	Cable, M12, 5-pin, angled connector female with molded cable, 2 m, PUR halogen free	DOL-1205-W02MC	6025909
	Cable, M12, 5-pin, angled connector female with molded cable, 5 m, PUR halogen free	DOL-1205-W05MC	6025910
	Cable, M12, 5-pin, angled connector female with molded cable, 10 m, PUR halogen free	DOL-1205-W10MC	6025911
 Illustration may differ	Cable, M12, 5-pin, angled connector female with molded cable, 2 m, PVC	DOL-1205-W02M	6008900
	Cable, M12, 5-pin, angled connector female with molded cable, 5 m, PVC	DOL-1205-W05M	6009869
	Cable, M12, 5-pin, angled connector female with molded cable, 10 m, PVC	DOL-1205-W10M	6010542
 Illustration may differ	Cable, M12, 8-pin, straight connector female with molded cable, 2 m, PUR halogen free	DOL-1208-G02MC	6035620
	Cable, M12, 8-pin, straight connector female with molded cable, 5 m, PUR halogen free	DOL-1208-G05MC	6035621
	Cable, M12, 8-pin, straight connector female with molded cable, 10 m, PUR halogen free	DOL-1208-G10MC	6035622
 Illustration may differ	Cable, M12, 8-pin, angled connector female with molded cable, 2 m, PUR halogen free	DOL-1208-W02MC	6035623
	Cable, M12, 8-pin, angled connector female with molded cable, 5 m, PUR halogen free	DOL-1208-W05MC	6035624
	Cable, M12, 8-pin, angled connector female with molded cable, 10 m, PUR halogen free	DOL-1208-W10MC	6035625

B

The clean solution



B



Product description

The LFP Inox is a hygienic level sensor for liquids using TDR technology – a process for determining the time of flight of electromagnetic waves. The time difference between the sent pulse and the reflected pulse is used to generate a level signal, both as a continuous value (analog output) and a freely positionable switching point (switching output). The use of robust FDA-compliant materials like stainless steel in an EHEDG-certified design

means that the LFP Inox guarantees optimal, unrestricted cleaning, even for the highest hygiene requirements. Its modular connection system allows simple and flexible installation in any application. Thanks to high temperature and pressure resistance, unrestricted use is possible under CIP and SIP conditions. The communication capability via IO-Link to the superordinate control units rounds off the profile.

At a glance

- Level monitoring in hygienic applications
- Manually cuttable monoprobe made from stainless steel 1.4404 up to 2,000 mm long with Ra ≤ 0.8 µm
- Process temperature up to 150 °C, process pressure up to 16 bar
- CIP/SIP resistant
- IP 67 and IP 69K enclosure rating
- Interchangeable hygienic process connections
- 3 in 1: Combined display, analog output and binary output
- Analog output 4 mA ... 20 mA / 0 V ... 10 V, switchable, plus two binary outputs

Your benefits

- Robust design increases service life
- High flexibility due to cuttable probe and interchangeable connection concept
- Cost savings due to multiple output signals: one system for both level detection and continuous level monitoring
- Time and cost savings due to low maintenance and quick commissioning
- No calibration or recalibration required for commissioning, thus saving time and costs



Additional information

- Detailed technical data B-31
- Ordering information B-32
- Type code B-33
- Dimensional drawings B-34
- Recommended accessories B-34

→ www.mysick.com/en/LFP_Inox

For more information, just enter the link or scan the QR code and get direct access to technical data, CAD design models, operating instructions, software, application examples and much more.



Detailed technical data

Features

Medium	Fluids
Measurement	Switch, continuous
Probe length	200 mm ... 2,000 mm
Process pressure	-1 bar ... 16 bar
Process temperature	-20 °C ... +150 °C
GOST approval	✓
RoHS certificate	✓
IO-Link	✓
EHEDG approval	Depending on type
3-A	Depending on type

Performance

Accuracy of sensor element ¹⁾	± 5 mm
Repeatability	≤ 2 mm
Resolution	< 2 mm
Response time	< 400 ms
Dielectricity constant	≥ 5
Conductivity	No limitation
Inactive area at process connector ¹⁾	25 mm
Inactive area at probe end ²⁾	10 mm

¹⁾ With parameterized tank with water under reference conditions, otherwise 40 mm.

²⁾ With water under reference conditions.

Mechanics

Wetted parts	316L (Ra ≤ 0.8 µm), PEEK
Process connection	See type code
Housing material	303
Housing design	With PMMA viewing window With closed cover
Max. probe load	≤ 6 Nm

Electronics

Supply voltage ¹⁾	12 V DC ... 30 V DC
Power consumption	≤ 75 mA at 24 V DC without output load
Initialization time	≤ 2 s
Protection class	III
Electrical connection	Round connector M12 x 1, 5-pin
Output signal ¹⁾	Analog output 4 mA ... 20 mA, 0 V ... 10 V automatic switching to a current or voltage output depending on the load, 1 PNP transistor output (Q1) and 1 PNP / NPN transistor output (Q2) switchable
Output load	4 mA ... 20 mA < 500 Ohm at V _S > 13.5 V, 4 mA ... 20 mA < 400 Ohm at V _S > 12 V, 0 V ... 10 V > 750 Ohm at V _S ≥ 14 V
Hysteresis	Min. 2 mm, freely adjustable
Signal voltage HIGH	V _S - 2 V
Signal voltage LOW	≤ 2 V

¹⁾ All connections are polarity protected. All outputs are overload and short-circuit protected.

Output current	< 100 mA
Inductive load	< 1 H
Capacitive load	100 nF
Enclosure rating	IP 67: EN 60529, IP 69K: EN 40050
Temperature drift	< 0.1 mm/K
Lower signal level	3.8 mA ... 4 mA
Upper signal level	20 mA ... 20.5 mA
EMC	EN 61326-1:2006, 2004/108/EG
Interference resistance	EN 61000-6-2:2005
Interference emission	EN 61000-6-4:2007
Single- and continuous shock	EN 60068-2-27

¹⁾ All connections are polarity protected. All outputs are overload and short-circuit protected.

B

Ambient data

Ambient operating temperature	-20 °C ... +60 °C
Ambient storage temperature	-40 °C ... +80 °C

Ordering information

The part numbers below show a selection of our common configurations and represent only a portion of the product portfolio. The type code on page B-33 indicates all possible configurations that can be ordered.

- **Enclosure rating:** IP 67: EN 60529, IP 69K: EN 40050
- **Process connection:** G $\frac{3}{4}$ A
- **Output signal:** 1 x PNP + 1 x PNP/NPN + 4 mA ... 20 mA / 0 V ... 10 V
- **Process temperature:** -20 °C ... +150 °C
- **Process pressure:** -1 bar ... 16 bar
- **Housing material:** 303
- **Housing design:** With PMMA viewing window
- **Electrical connection:** Round connector M12 x 1, 5-pin

Probe length	Model name	Part no.
300 mm	LFP0300-G1NMB	1053288
400 mm	LFP0400-G1NMB	1052069
500 mm	LFP0500-G1NMB	1052070
600 mm	LFP0600-G1NMB	1052071
700 mm	LFP0700-G1NMB	1052072
800 mm	LFP0800-G1NMB	1052073
900 mm	LFP0900-G1NMB	1052074
1,000 mm	LFP1000-G1NMB	1052075
1,100 mm	LFP1100-G1NMB	1052076
1,200 mm	LFP1200-G1NMB	1052077
1,300 mm	LFP1300-G1NMB	1052078
1,400 mm	LFP1400-G1NMB	1052079
1,500 mm	LFP1500-G1NMB	1052080
1,600 mm	LFP1600-G1NMB	1052081
1,700 mm	LFP1700-G1NMB	1052082
1,800 mm	LFP1800-G1NMB	1052083
1,900 mm	LFP1900-G1NMB	1052084
2,000 mm	LFP2000-G1NMB	1052085

- **Enclosure rating:** IP 67: EN 60529, IP 69K: EN 40050
- **Process connection:** G 3/4 A
- **Output signal:** 1 x PNP + 1 x PNP/NPN + 4 mA ... 20 mA / 0 V ... 10 V
- **Process temperature:** -20 °C ... +150 °C
- **Process pressure:** -1 bar ... 16 bar
- **Housing material:** 303
- **Housing design:** With closed cover
- **Electrical connection:** Round connector M12 x 1, 5-pin

Probe length	Model name	Part no.
300 mm	LFP0300-G2NMB	1056287
400 mm	LFP0400-G2NMB	1056225
500 mm	LFP0500-G2NMB	1056288
600 mm	LFP0600-G2NMB	1056289
700 mm	LFP0700-G2NMB	1056290
800 mm	LFP0800-G2NMB	1056291
900 mm	LFP0900-G2NMB	1056292
1,000 mm	LFP1000-G2NMB	1056204
1,100 mm	LFP1100-G2NMB	1056293
1,200 mm	LFP1200-G21NMB	1056294
1,300 mm	LFP1300-G2NMB	1056295
1,400 mm	LFP1400-G2NMB	1056296
1,500 mm	LFP1500-G2NMB	1056297
1,600 mm	LFP1600-G2NMB	1056298
1,700 mm	LFP1700-G2NMB	1056299
1,800 mm	LFP1800-G2NMB	1056300
1,900 mm	LFP1900-G2NMB	1056301
2,000 mm	LFP2000-G2NMB	1056302

Type code

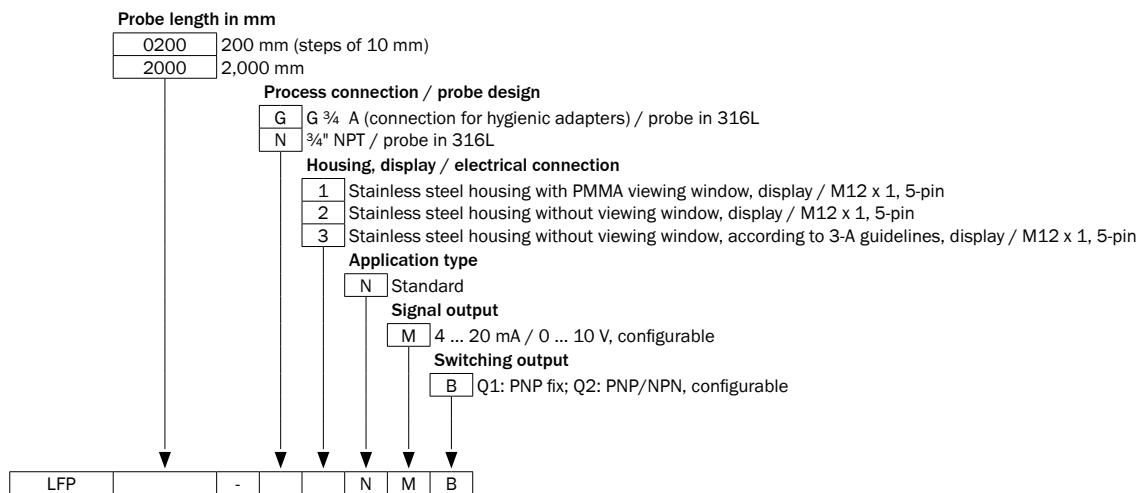

Not all variations of the type code can be combined!

Dimensional drawings

dimensions in mm (inch)

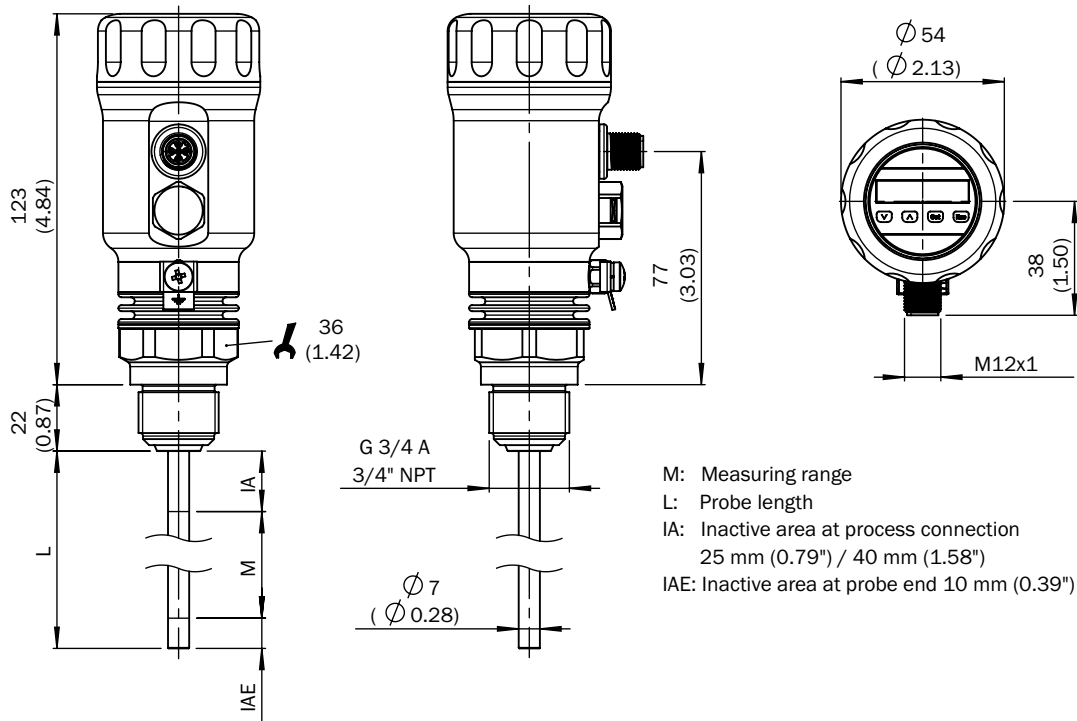

Recommended accessories

Adapters

	Brief description	Model name	Part no.
	Hygienic process connection adapter, collar connector (DIN 11864-1) DN 25 Form A with grooved union nut	BEF-HA-641D25-LFP1	2058795
	Hygienic process connection adapter, collar connector (DIN 11864-2) DN 25 Form A	BEF-HA-642D25-LFP1	2058823
	Hygienic process connection adapter, collar clamp connector (DIN 11864-3) BKS DN 25 Form A	BEF-HA-643D25-LFP1	2058821
	Hygienic process connection adapter, conical connector (DIN 11851) DN 25 with grooved union nut	BEF-HA-851D25-LFP1	2058138
	Hygienic process connection adapter, conical connector (DIN 11851) DN 40 with grooved union nut, material 1.4404 (Ra ≤ 0.8 μm)	BEF-HA-851D40-LFP1	2058139
	Hygienic process connection adapter, conical connector (DIN 11851) DN 50 with grooved union nut	BEF-HA-851D50-LFP1	2058141
	Hygienic process connection adapter, conical connector (DIN 11851) DN 65 with grooved union nut	BEF-HA-851D65-LFP1	2063328
	Hygienic process connection adapter, Tri-Clamp 1" and 1 1/2"	BEF-HA-TCLI10-LFP1	2058808
	Hygienic process connection adapter, Tri-Clamp 1" and 1 1/2" with leakage indication port according to 3-A guidelines	BEF-HA-TCLI10-LFP3	2058851
	Hygienic process connection adapter, Tri-Clamp 2"	BEF-HA-TCLI20-LFP1	2058824
	Hygienic process connection adapter, Varivent Connector Type N	BEF-HA-VARTYN-LFP1	2058822

Flange

	Brief description	Model name	Part no.
	Welded flange/welded connector, process connection Tri-Clamp 1"	BEF-FL-TCLI10-LFV2	5321678
	Welded flange/welded connector, process connection Tri-Clamp 2"	BEF-FL-TCLI20-LFV2	5321679

Terminal and alignment brackets

	Brief description	Model name	Part no.
	Centering for bypass- and immersion tube installation with diameter 40 mm ... 100 mm	BEF-FL-BYRD40-LFP1	2059612

Others

	Brief description	Model name	Part no.
	IO-Link-Master	IOLSHPB-P3104R01	6039728

B

Plug connectors and cables

	Brief description	Model name	Part no.
	Cable, M12, 5-pin, straight connector female with molded cable, 2 m, PVC, food specification	DOL-1205-G02MN	6028140
	Cable, M12, 5-pin, straight connector female with molded cable, 5 m, PVC, food specification	DOL-1205-G05MN	6028141
	Cable, M12, 5-pin, straight connector female with molded cable, 10 m, PVC, food specification	DOL-1205-G10MN	6028142

At a high level



Product description

The level probe LFH is a robust pressure transmitter for continuous level measurement. The liquid column above the probe creates a hydrostatic pressure which is a direct indicator for the liquid level. Through its permanently connected cable the LFH is submerged into the liquid. The precise measurement technology is integrated in a robust stainless steel housing. To meet the diverse requirements, the level probe

LFH is available in two versions, standard and enhanced. For the enhanced variant there is a number of options available that extend the range of applications significantly such as a maximum cable length of 250 m (standard version: 100 m), an integrated temperature measurement, a surge protection and a connection cable with highly resistant FEP sheathing (up to 100 m).

At a glance

- Immersion depth up to 100 m
- Available with various cable lengths
- Measuring ranges from 0 bar ... 0.1 bar up to 0 bar ... 25 bar
- Stainless steel membrane
- Hermetically sealed stainless steel housing with PA protection cap
- Cable made from PUR, FEP-cable for aggressive media optionally available
- Optional temperature measurement with integrated Pt100 element
- Optional surge protection

Your benefits

- Enables level measurement under difficult conditions where other measurement technologies fail
- Rugged and reliable through robust mechanical design and high-grade materials
- For cleaning purposes, the probe can easily be taken out of the liquid
- No openings required in the wall of the vessel



Additional information

Detailed technical data	B-37
Ordering information	B-38
Type code	B-39
Dimensional drawings	B-40
Recommended accessories	B-41

→ www.mysick.com/en/LFH

For more information, just enter the link or scan the QR code and get direct access to technical data, CAD design models, operating instructions, software, application examples and much more.



Detailed technical data

Features

Pressure units	bar, mH ₂ O
Measuring ranges	Standard version: From 0 bar ... 0.25 bar up to 0 bar ... 10 bar Enhanced version: From 0 bar ... 0.1 bar up to 0 bar ... 25 bar
Process temperature	-10 °C ... +50 °C -10 °C ... +85 °C with FEP cable (optional for enhanced variant)
Signal output and maximum ohmic load R _A	4 mA ... 20 mA, 2-wire, R _A ≤ (L* - 10 V) / 0.02 A - (0.14 x cable length in m) [Ohm] 0 V ... 10 V, 3-wire optional with enhanced variant, R _A > 100 kOhm 0 V ... 5 V, 3-wire optional with enhanced variant, R _A > 100 kOhm
Temperature measurement	Pt100, 4-wire optional for enhanced variant, I _{max.} = 3 mA, I _{meas.} = 1 mA

Performance

Non-linearity	≤ ± 0.2 % of span (Best Fit Straight Line, BFSL) according to IEC 61298-2
Accuracy ¹⁾	≤ ± 0.25 % of span for enhanced version p ≥ 0.25 bar ≤ ± 0.5 % of span for standard version and enhanced version p < 0.25 bar
Non-repeatability	≤ ± 0.1 % of span
Long-term drift/one-year stability	≤ ± 0.2 % of span (at reference conditions)
Temperature coefficient in rated temperature range	Mean TC of zero: ≤ 0.2 % of span / 10 K (< 0.4 % for pressure ranges ≤ 0.25 bar) Mean TC of span: ≤ 0.2 % of span / 10 K
Rated temperature range	0 °C ... +50 °C

¹⁾ Including non-linearity, hysteresis, zero point and full scale error (corresponds to error of measurement according to IEC 61298-2). Adjusted in vertical mounting position with pressure connection facing downwards.

Mechanics/electronics

Wetted parts	Housing: Stainless steel, Pressure connection/membrane: Stainless steel, protection cap: PA
Electrical connection	Cable PUR Cable FEP optionally available for enhanced variant
Supply voltage	10 V DC ... 30 V DC 14 V DC ... 30 V DC with output signal 0 V ... 10 V (only with enhanced variant)
Electrical safety	Protection class: III Short-circuit protection: Q _A towards M Reverse polarity protection: L* towards M Surge protection: According to EN 61000-4-5 (1.5 J) optional for enhanced variant
Dielectric strength	500 V DC, NEC Class 02 power supply (low voltage and low current max. 100 VA even under fault conditions)
CE-conformity	EMC directive: 2004/108/EC, EN 61 326-2-3
Sensor weight	0.18 kg standard version 0.2 kg enhanced version
Cabel weight	0.08 kg/m
Enclosure rating	IP 68

Ambient data

Storage temperature	-30 °C ... +80 °C
---------------------	-------------------

B

Ordering information

The part numbers below show a selection of our common configurations and represent only a portion of the product portfolio. The type code on page B-39 indicates all possible configurations that can be ordered.

LFH standard version

- **Enclosure rating:** IP 68
- **Output signal:** 4 mA ... 20 mA
- **Process temperature:** -10 °C ... +50 °C
- **Electrical connection:** Cable PUR

Measuring range	Cable length	Model name	Part no.
0 bar ... 0.25 bar	1.5 m	LFH-SBX25G1AS01SZO	6040938
	3 m	LFH-SBX25G1AS03SZO	6040939
	5 m	LFH-SBX25G1AS05SZO	6040940
	10 m	LFH-SBX25G1AS10SZO	6040941
0 bar ... 0.4 bar	5 m	LFH-SBX40G1AS05SZO	6040942
	10 m	LFH-SBX40G1AS10SZO	6040943
	15 m	LFH-SBX40G1AS15SZO	6040944
	20 m	LFH-SBX40G1AS20SZO	6040945
0 bar ... 0.6 bar	5 m	LFH-SBX60G1AS05SZO	6040946
	10 m	LFH-SBX60G1AS10SZO	6040947
	15 m	LFH-SBX60G1AS15SZO	6040948
	20 m	LFH-SBX60G1AS20SZO	6040949
0 bar ... 1 bar	10 m	LFH-SB1X0G1AS10SZO	6040950
	15 m	LFH-SB1X0G1AS15SZO	6040951
	20 m	LFH-SB1X0G1AS20SZO	6040952
	25 m	LFH-SB1X0G1AS25SZO	6040953
0 bar ... 1.6 bar	15 m	LFH-SB1X6G1AS15SZO	6040954
	20 m	LFH-SB1X6G1AS20SZO	6040955
	25 m	LFH-SB1X6G1AS25SZO	6040956
	30 m	LFH-SB1X6G1AS30SZO	6040957

B

Type code

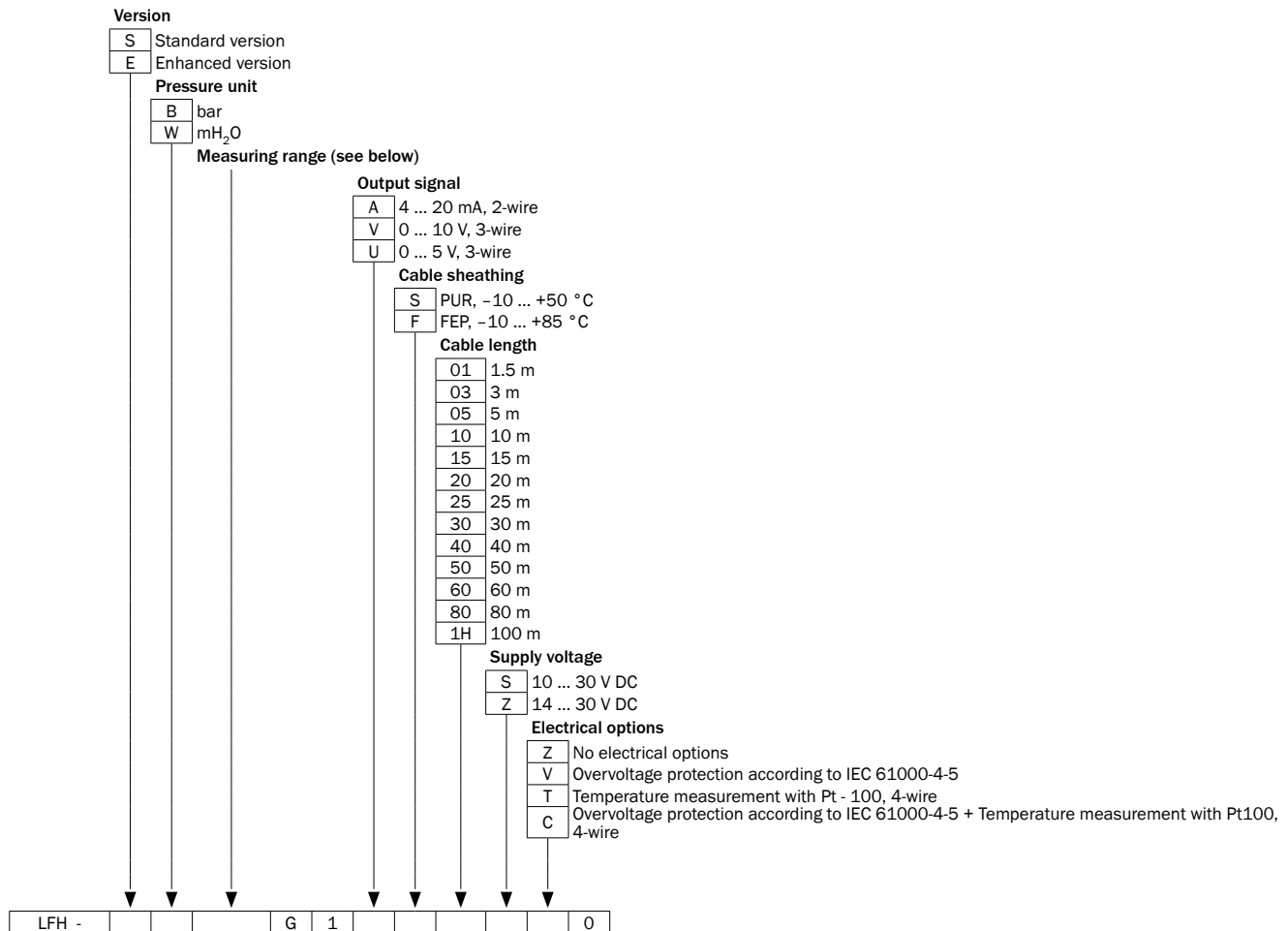

B

Not all variations of the type code can be combined!

Measuring range

	bar / Gauge pressure
X10	0 ... 0.1 bar
X16	0 ... 0.16 bar
X25	0 ... 0.25 bar
X40	0 ... 0.4 bar
X60	0 ... 0.6 bar
1X0	0 ... 1 bar
1X6	0 ... 1.6 bar
2X5	0 ... 2.5 bar
4X0	0 ... 4 bar
6X0	0 ... 6 bar
010	0 ... 10 bar
016	0 ... 16 bar
025	0 ... 25 bar

	mH ₂ O / Gauge pressure
1X0	0 ... 1 mH ₂ O
1X6	0 ... 1.6 mH ₂ O
2X5	0 ... 2.5 mH ₂ O
4X0	0 ... 4 mH ₂ O
6X0	0 ... 6 mH ₂ O
010	0 ... 10 mH ₂ O
016	0 ... 16 mH ₂ O
025	0 ... 25 mH ₂ O
040	0 ... 40 mH ₂ O
060	0 ... 60 mH ₂ O
100	0 ... 100 mH ₂ O
160	0 ... 160 mH ₂ O
250	0 ... 250 mH ₂ O

Dimensional drawings

dimensions in mm (inch)

B

Standard version (Immersion depth up to 100 m)

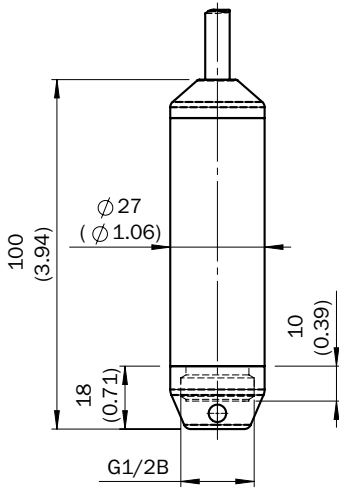

Enhanced version with PUR cable (Immersion depth up to 100 m)

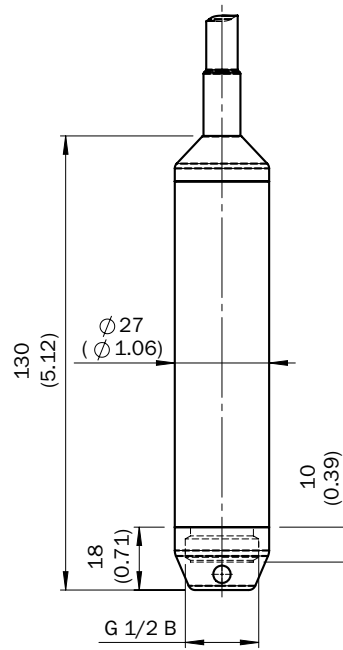

Enhanced version with FEP cable (Immersion depth up to 100 m)

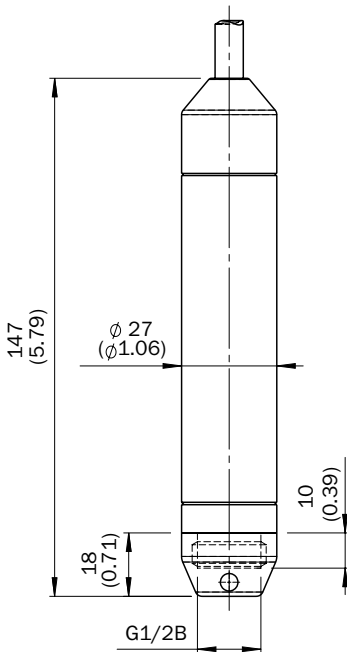

Recommended accessories

Adapters/distributors

	Enclosure rating	Model name	Part no.
	Connection box for electrical follow-up of level probe LFH. With integrated pressure compensation and terminal block. Enclosing rating: IP 67. Material: Polycarbonate, grey.	ASK-CB-LFHPC0-0001	5324310

Terminal and alignment brackets

	Brief description	Model name	Part no.
	Cable clamp for mounting the connection cable of the level sensor, max. tensile strength = 2.5 kN (not to be used with FEP cable)	BEF-CC-LFH001-0001	5324307

Protection filter

	Brief description	Model name	Part no.
	Protection filter for level probe LFH. Prevents humidity from entering the ventilation tube of the connection cable. For self-mounting at cable end.	APR-VF-LFH001-0001	5324309

Other mounting accessories

	Brief description	Model name	Part no.
	Additional weight for stabilizing the LFH level sensor in moving liquids. Thread G 1/2 female, is fastened to the level sensor instead of the protective cap. Weight: 500 g. Material: Stainless steel 1.4571.	BEF-AW-LFHSST-0001	5324308

B

Tough, non-contact, pressure-resistant



B



Product description

The product family UP56 of ultrasonic level sensors is the ideal solution for demanding applications. The teflon-protected transducer handles overpressure up to 6 bar (87 psi) and is resistant against numerous difficult fluids. Wetted parts can be chosen either as stainless steel or PVDF, thus making the UP56 the perfect solution for measurement in aggressive, viscous, or abrasive liquids, or bulk solids. By combining two output signals in one

device, new cost-effective solutions can be created for measurement and integration into the system. With two switching outputs, the UP56 can measure dry running and overflow in one device. Combining analog and a switching output enables continuous level measurement with a separate overflow signal. Parameters are easy to set via an integrated display, PC or the connect+ adapter.

At a glance

- Non-contact level measurement up to 3.4 m operating distance / 8.0 m limit scanning distance
- Pressure resistant up to 6 bar (87 psi)
- Transducer protected by PVDF cover for increased resistance
- 3 in 1: Continuous level measurement, level switch and display
- Analog output switchable between 4 mA ... 20 mA and 0 V ... 10 V
- Process connector thread G 1 and G 2
- IP 67 enclosure rating
- Easy to set parameters, also via connect+

Your benefits

- Non-contact measurement in pressurized containers – no wear over time
- Easy to set parameters, saves time
- Flexible measurement system for different container sizes – standardization and stock reduction
- One product for point level and continuous applications, reduces the number of sensors required



Additional information

Detailed technical data. B-43
 Ordering information. B-44
 Type code. B-45
 Dimensional drawings B-46
 Recommended accessories. B-46

→ www.mysick.com/en/UP56

For more information, just enter the link or scan the QR code and get direct access to technical data, CAD design models, operating instructions, software, application examples and much more.



Detailed technical data

Features

	UP56-211	UP56-212	UP56-213	UP56-214
Medium	Fluids, bulk solids			
Measurement	Switch, continuous			
Operating distance	30 mm ... 250 mm	85 mm ... 350 mm	200 mm ... 1,300 mm	350 mm ... 3,400 mm
Limiting scanning distance ¹⁾	30 mm ... 990 mm	85 mm ... 1,500 mm	200 mm ... 5,000 mm	350 mm ... 8,000 mm
Process pressure	0 bar ... 6 bar, gauge pressure			
Process temperature	-25 °C ... +70 °C			

¹⁾ At 6 bar gauge.

Performance

	UP56-211	UP56-212	UP56-213	UP56-214
Accuracy of sensor element ¹⁾	≤ 2 %			
Repeatability ¹⁾	± 0.15 %			
Resolution	≤ 0.18 mm			
Response time ²⁾	≤ 68 ms	≤ 84 ms	≤ 180 ms	≤ 240 ms

¹⁾ Of final value.

²⁾ Recovery time 32 ms ... 180 ms according to EMC EN 60947-5-7.

Mechanics

	UP56-211	UP56-212	UP56-213	UP56-214
Process connection	G 1 A PN 6			G 2 A PN 6
Housing material	Stainless steel 1.4571, PBT, TPU			Stainless steel 1.4571, PBT, TPU, PVDF

Electronics

	UP56-211	UP56-212	UP56-213	UP56-214
Supply voltage ¹⁾	9 V DC ... 30 V DC			
Residual ripple	± 10 %			
Power consumption ²⁾	≤ 80 mA			
Electrical connection	Round connector M12 x 1, 5-pin			
Hysteresis	3 mm	5 mm	20 mm	50 mm
Analog output ^{3) 4)}	Qa: 4 mA ... 20 mA / 0 V ... 10 V			
Signal voltage HIGH	$V_S - 3 V$			
Time delay before availability	≤ 300 ms			
Enclosure rating	IP 67			
Ultrasonic frequency	320 kHz		180 kHz	120 kHz
Ultrasonic transducer	PTFE coating, FFKM			

¹⁾ Reverse-polarity protected.

²⁾ At 24 V DC without output load.

³⁾ Short-circuit protected, reversible.

⁴⁾ Automatic switching between voltage and current outputs dependent on load 4 mA ... 20 mA: RL ≤ 100/ at 9 V ≤ U_b ≤ 20 V; RL ≤ 500/ at U_b ≥ 20 V; 0 V ... 10 V: RL ≥ 100 k/ at U_b ≥ 15 V, short-circuit protected.

Ambient data

Ambient operating temperature ¹⁾	-25 °C ... +70 °C
Ambient storage temperature	-40 °C ... +85 °C

¹⁾ Temperature compensation at -25 °C ... 70 °C, can be switched off.

Ordering information

The part numbers below show a selection of our common configurations and represent only a portion of the product portfolio. The type code on page B-45 indicates all possible configurations that can be ordered.

UP56-211

- Enclosure rating: IP 67
- Process connection: G 1 A PN 6
- Process temperature: -25 °C ... +70 °C
- Process pressure: 0 bar ... 6 bar
- Operating distance: 30 mm ... 250 mm
- Limiting scanning distance: 30 mm ... 990 mm (at 6 bar gauge.)
- Electrical connection: Round connector M12 x 1, 5-pin

Output signal	Housing material	Model name	Part no.
1 x PNP + 4 mA ... 20 mA / 0 V ... 10 V	Stainless steel 1.4571, without display	UP56-211128	6048700
	Stainless steel 1.4571, PBT, TPU, with display	UP56-211118	6041658
2x NPN	Stainless steel 1.4571, PBT, TPU, with display	UP56-211114	6041664
2x PNP	Stainless steel 1.4571, PBT, TPU, with display	UP56-211112	6041661

UP56-212

- Enclosure rating: IP 67
- Process connection: G 1 A PN 6
- Process temperature: -25 °C ... +70 °C
- Process pressure: 0 bar ... 6 bar
- Operating distance: 85 mm ... 350 mm
- Limiting scanning distance: 85 mm ... 1,500 mm (At 6 bar gauge.)
- Electrical connection: Round connector M12 x 1, 5-pin

Output signal	Housing material	Model name	Part no.
1 x PNP + 4 mA ... 20 mA / 0 V ... 10 V	Stainless steel 1.4571, without display	UP56-212128	6048701
	Stainless steel 1.4571, PBT, TPU, with display	UP56-212118	6041659
2x NPN	Stainless steel 1.4571, PBT, TPU, with display	UP56-212114	6041665
2x PNP	Stainless steel 1.4571, PBT, TPU, with display	UP56-212112	6041662

UP56-213

- Enclosure rating: IP 67
- Process connection: G 1 A PN 6
- Process temperature: -25 °C ... +70 °C
- Process pressure: 0 bar ... 6 bar
- Operating distance: 200 mm ... 1,300 mm
- Limiting scanning distance: 200 mm ... 5,000 mm (at 6 bar gauge.)
- Electrical connection: Round connector M12 x 1, 5-pin

Output signal	Housing material	Model name	Part no.
1 x PNP + 4 mA ... 20 mA / 0 V ... 10 V	Stainless steel 1.4571, without display	UP56-213128	6048702
	Stainless steel 1.4571, PBT, TPU, with display	UP56-213118	6041660
2x NPN	Stainless steel 1.4571, PBT, TPU, with display	UP56-213114	6041666
2x PNP	Stainless steel 1.4571, PBT, TPU, with display	UP56-213112	6041663

UP56-214

- **Enclosure rating:** IP 67
- **Process connection:** G 2 A PN 6
- **Process temperature:** -25 °C ... +70 °C
- **Process pressure:** 0 bar ... 6 bar
- **Operating distance:** 350 mm ... 3,400 mm
- **Limiting scanning distance:** 350 mm ... 8,000 mm (at 6 bar gauge.)
- **Electrical connection:** Round connector M12 x 1, 5-pin

Output signal	Housing material	Model name	Part no.
1 x PNP + 4 mA ... 20 mA / 0 V ... 10 V	Stainless steel 1.4571, without display	UP56-214128	6048703
	Stainless steel 1.4571, PBT, TPU, with display	UP56-214118	6041693
	PVDF, PBT, TPU, with display	UP56-214178	6039866
2x NPN	Stainless steel 1.4571, PBT, TPU, with display	UP56-214114	6041694
	PVDF, PBT, TPU, with display	UP56-214174	6039865
2x PNP	Stainless steel 1.4571, PBT, TPU, with display	UP56-214112	6041695
	PVDF, PBT, TPU, with display	UP56-214172	6039864

B

Type code

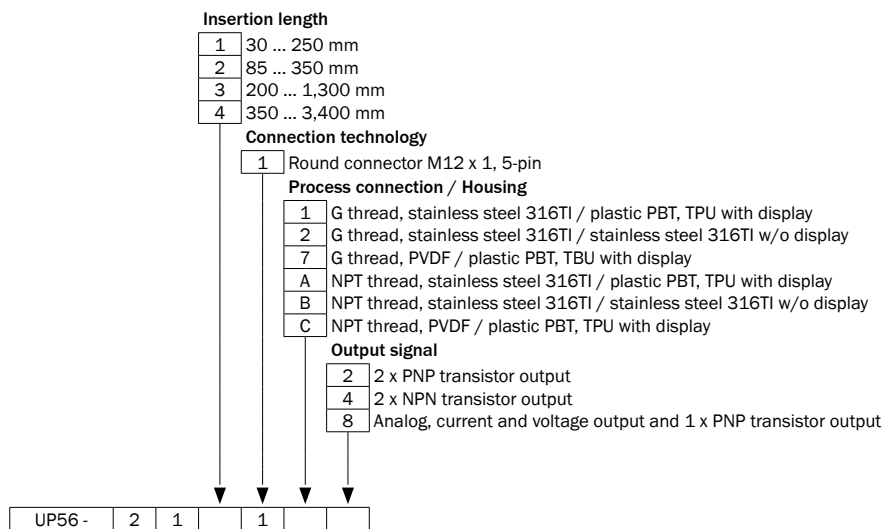

Not all variations of the type code can be combined!

Dimensional drawings

dimensions in mm (inch)

UP56-211/ 212/ 213

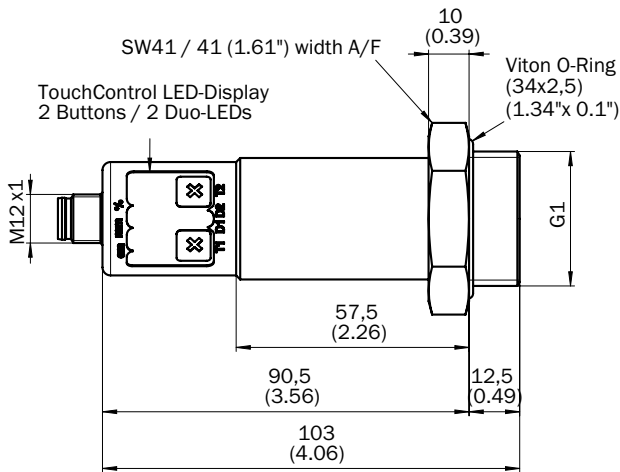

UP56-211/ 212/ 213 all-metal

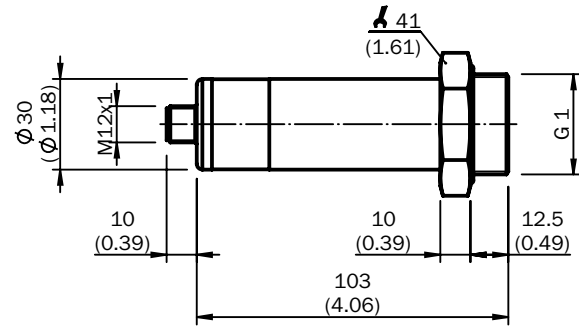

UP56-214

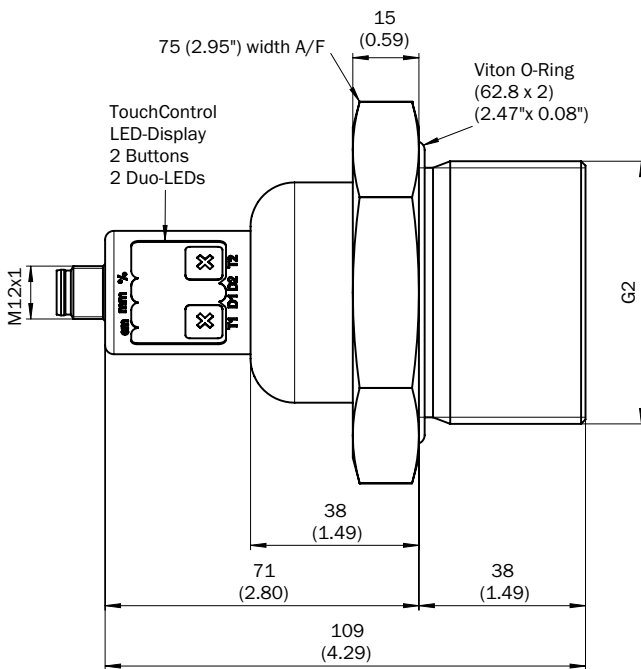

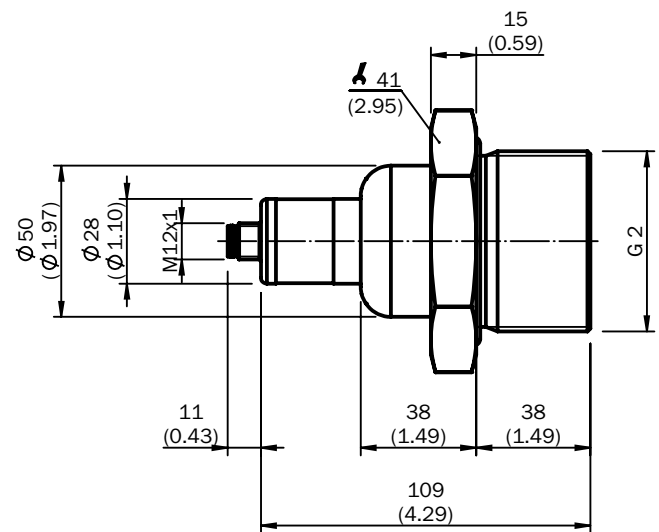

UP56-214 all-metal



Recommended accessories





Flanges

	Brief description	Model name	Part no.
	Welded flange, process connection G 1	BEF-FL-316G10-UP56	4064295
	Welded flange/welded connector, process connection G 2	BEF-FL-316G20-UP56	4063263

Configuration software

	Software Product	Model name	Part no.
	CPA connect+	CPA connect Plus	6037782

Plug connectors and cables

	Brief description	Model name	Part no.
 Illustration may differ	Cable, M12, 5-pin, straight connector female with molded cable, 2 m, PVC	DOL-1205-G02M	6008899
	Cable, M12, 5-pin, straight connector female with molded cable, 5 m, PVC	DOL-1205-G05M	6009868
	Cable, M12, 5-pin, straight connector female with molded cable, 10 m, PVC	DOL-1205-G10M	6010544
 Illustration may differ	Cable, M12, 5-pin, straight connector female with molded cable, 5 m, PUR halogen free	DOL-1205-G05MC	6025907
	Cable, M12, 5-pin, straight connector female with molded cable, 10 m, PUR halogen free	DOL-1205-G10MC	6025908
 Illustration may differ	Cable, M12, 5-pin, angled connector female with molded cable, 2 m, PUR halogen free	DOL-1205-W02MC	6025909
	Cable, M12, 5-pin, angled connector female with molded cable, 5 m, PUR halogen free	DOL-1205-W05MC	6025910
	Cable, M12, 5-pin, angled connector female with molded cable, 10 m, PUR halogen free	DOL-1205-W10MC	6025911
 Illustration may differ	Cable, M12, 5-pin, angled connector female with molded cable, 2 m, PVC	DOL-1205-W02M	6008900
	Cable, M12, 5-pin, angled connector female with molded cable, 5 m, PVC	DOL-1205-W05M	6009869
	Cable, M12, 5-pin, angled connector female with molded cable, 10 m, PVC	DOL-1205-W10M	6010542
 Illustration may differ	Cable, M12, 8-pin, straight connector female with molded cable, 2 m, PUR halogen free	DOL-1208-G02MC	6035620

B

Pure reliability



B



Product description

The non-contact ultrasonic level sensors from the UP56 Pure product family are a range of products specialized for wet chemical processes in the electronic and solar industry. Due to their PTFE-protected transducer they are very hardwearing and durable and are designed to be used in highly concentrated acids and alkalines. The UP56 Pure is easy and fast to integrate thanks to the industry-specific GF process connection. A high level of accuracy can also

be achieved with fluctuating liquid densities, thus facilitating the use of dosing applications. In systems where the installation is extremely cramped, the UP56 Pure Mini is the perfect solution thanks to its very compact design. Use in containers with a lot of built-in components is easily resolved by means of an immersion pipe. The measurement range, output, and filters of the UP56 product family is easy and convenient to adjust with the PC-based programming tool Connect+.

At a glance

- Ultrasonic level sensor with very high chemical resistance
- Non-contact measurement in immersion pipe of up to 1500 mm
- PTFE-coated membrane and GF D40 process connection made of PTFE
- Pressure resistant up to 6 bar, temperature resistant up to 85 °C
- Different sizes available
- Analog output selectable between 4 mA ... 20 mA and 0 V ... 10 V
- Switching output for monitoring the maximum and minimum limit

Your benefits

- Non-contact and non-wearing measurement reduces maintenance and service cost
- Sensor replacement possible even with chemicals present, thus saving time and increasing availability
- Universally applicable with acidic and alkaline processes
- Flexible measurement system for different container sizes provides cost reductions
- High-precision measurements, even in liquids with density fluctuations
- Faultless operation with very limited installation space in the container
- Switching and analog output in one sensor reduces amount of wiring, I/O and stocking costs
- Simple and time-saving configuration with Connect+



Additional information

- Detailed technical data..... B-49
- Ordering information..... B-50
- Type code..... B-50
- Dimensional drawings B-50

→ www.mysick.com/en/UP56_Pure

For more information, just enter the link or scan the QR code and get direct access to technical data, CAD design models, operating instructions, software, application examples and much more.



Detailed technical data

Features

	UP56-211	UP56-212	UP56-216
Medium	Fluids		
Measurement	Switch, continuous		
Measuring range in tank	30 mm ... 250 mm	85 mm ... 350 mm	65 mm ... 700 mm
Measuring range immersion tube	30 mm ... 500 mm	85 mm ... 1,500 mm	65 mm ... 1,500 mm
Process pressure	0 bar ... 2 bar, gauge pressure for mini 0 bar ... 6 bar, gauge pressure		
Process temperature	-25 °C ... +85 °C		

Performance

Accuracy of sensor element ¹⁾	≤ 1 %
Repeatability ¹⁾	± 0.15 %
Resolution	≤ 0.025 mm ≤ 0.18 mm
Response time	≤ 68 ms ²⁾ ≤ 84 ms

¹⁾ Of final value.

²⁾ Recovery time 32 ms ... 180 ms according to EMC EN 60947-5-7.

Mechanics

Process connection	D40 GF connection
Housing material	PTFE, PP
Housing design	Standard Mini

Electronics

	UP56-211	UP56-212	UP56-216
Supply voltage ¹⁾	9 V DC ... 30 V DC		
Residual ripple	± 10 %		
Power consumption ²⁾	≤ 80 mA		
Electrical connection	Round connector M12 x 1, 5-pin		
Hysteresis	3 mm	5 mm	
Analog output ^{3) 4)}	Q _A : 4 mA ... 20 mA / 0 V ... 10 V		
Signal voltage HIGH	V _S -3 V		
Time delay before availability	≤ 300 ms		
Enclosure rating	IP 67		
Ultrasonic frequency	320 kHz	200 kHz	
Ultrasonic transducer	PTFE coating, FFKM		

¹⁾ Reverse-polarity protected.

²⁾ At 24 V DC without output load.

³⁾ Short-circuit protected, reversible.

⁴⁾ Automatic switching between voltage and current outputs dependet on load 4 mA ... 20 mA: RL ≤ 100/ at 9 V ≤ U_b ≤ 20 V; RL ≤ 500/ at U_b ≥ 20 V; 0 V ... 10 V: RL ≥ 100 k/at U_b ≥ 15 V, short-circuit protected.

Ambient data

Ambient operating temperature ¹⁾	-25 °C ... +60 °C
Ambient storage temperature	-40 °C ... +85 °C

¹⁾ Temperature compensation at -25 °C ... 50 °C, can be switched off.

Ordering information

The part numbers below show a selection of our common configurations and represent only a portion of the product portfolio. The type code on page B-50 indicates all possible configurations that can be ordered.

- Enclosure rating: IP 67
- Process connection: D40 GF connection
- Process temperature: -25 °C ... +85 °C
- Housing material: PTFE, PP
- Electrical connection: Round connector M12 x 1, 5-pin

B

Output signal	Process pressure	Measuring range in tank	Measuring range immersion tube	Model name	Part no.
1 x PNP + 4 mA ... 20 mA / 0 V ... 10 V	0 bar ... 6 bar	30 mm ... 250 mm	30 mm ... 500 mm	UP56-211148	6048942
		65 mm ... 700 mm	65 mm ... 1,500 mm	UP56-216148	6049450
		85 mm ... 350 mm	85 mm ... 1,500 mm	UP56-212148	6048943
4 mA ... 20 mA	0 bar ... 2 bar	30 mm ... 250 mm	30 mm ... 500 mm	UP56-211156	6050441
		65 mm ... 700 mm	65 mm ... 1,500 mm	UP56-216156	6049617
		85 mm ... 350 mm	85 mm ... 1,500 mm	UP56-212156	6049945

Type code

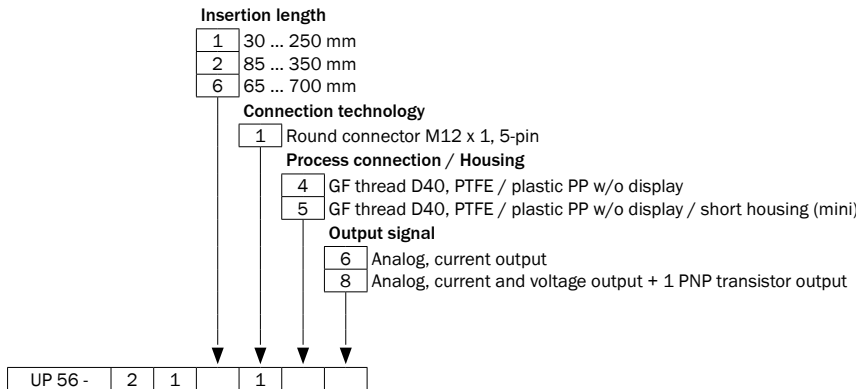

Not all variations of the type code can be combined!

Dimensional drawings

dimensions in mm (inch)

UP56 Pure

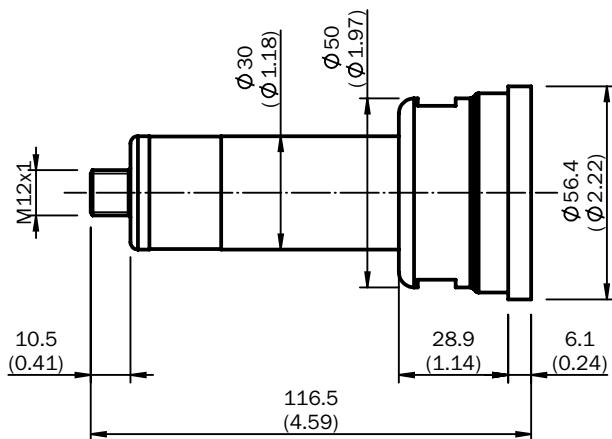

UP56 Pure mini

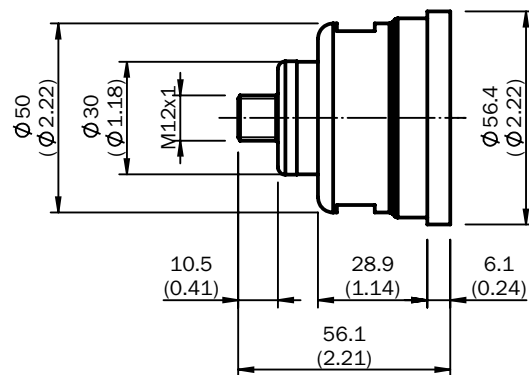

B

Simple, compact and robust



B



Product description

The MHF15 is a compact optical level limit switch that is easy to commission. The sensor is based on SICK's energetic photoelectric proximity sensor technology, which has been tested and optimized over a number of decades. This sensor has a simple, robust and reliable construction. The use of high-quality materials, such as stainless steel 1.4404 and polysulfone, combined with the IP 69K-rated housing, provides

reliability not only on the process side, but also in situations where there are adverse ambient conditions outside the tank. In addition, fast, hassle-free commissioning does not require medium calibration, reducing commissioning costs and maintenance. The optical technology makes the MHF15 particularly well-suited to use with water-based media.

At a glance

- Robust level monitoring in liquid without additional requirements
- Small, compact design; no medium calibration required
- Process temperature up to 55 °C, process pressure up to 16 bar
- IP 67 and IP 69K enclosure rating
- Process connection G ½
- Highly medium resistant due to stainless steel housing 1.4404, polysulfone apex
- Output available as PNP or NPN transistor
- FDA-compliant, UL

Your benefits

- Small, compact sensor ideal for difficult installation conditions with limited space
- Quick commissioning without medium calibration saves time and money
- No moving mechanical parts reduce maintenance and eliminate the need to recalibrate – even after long periods of use



Additional information

Detailed technical data B-53
 Ordering information B-54
 Type code B-54
 Dimensional drawing B-54
 Recommended accessories B-54

→ www.mysick.com/en/MHF15

For more information, just enter the link or scan the QR code and get direct access to technical data, CAD design models, operating instructions, software, application examples and much more.



Detailed technical data

Features

Medium	Fluids
Measurement	Switch
Light source	LED
Type of light	Red light
Wave length	650 nm
Process pressure	-0.5 bar ... 16 bar
Process temperature	-25 °C ... +55 °C
GOST approval	✓
UL approval	✓
RoHS certificate	✓

Performance

Response time	2 ms
---------------	------

Mechanics

Wetted parts	Stainless steel 1.4404, polysulfon, NBR
Process connection	G ½
Housing material	Stainless steel 1.4404

Electronics

	1 x PNP	1 x NPN
Supply voltage ¹⁾	10 V DC ... 30 V DC	
Residual ripple ²⁾	≤ 5 V _{pp}	
Power consumption	≤ 30 mA at 24 V DC without output load	
Protection class	III	
Electrical connection	Round connector M12 x 1, 4-pin	
Output signal ³⁾	1 x PNP	1x NPN
Switching mode	Normally closed Normally open	Normally open Normally closed
Signal voltage HIGH	V _S - 2.9 V	
Signal voltage LOW	Approx. 0 V	≤ 2.9 V
Output current ³⁾	≤ 100 mA	
Switching frequency ⁴⁾	250 Hz	
Enclosure rating	IP 67: EN 60529, IP 69K: EN 40050	

¹⁾ V_S connections reverse-polarity protected.

²⁾ May not exceed or fall short of V_S tolerances.

³⁾ Output overcurrent and short-circuit protected.

⁴⁾ With light/dark ratio 1:1.

Ambient data

Ambient operating temperature	-25 °C ... +55 °C
Ambient storage temperature	-25 °C ... +70 °C

Ordering information

The part numbers below show a selection of our common configurations and represent only a portion of the product portfolio. The type code on page B-54 indicates all possible configurations that can be ordered.

- Enclosure rating: IP 67: EN 60529, IP 69K: EN 40050
- Process connection: G 1/2
- Process temperature: -25 °C ... +55 °C
- Process pressure: -0.5 bar ... 16 bar
- Housing material: Stainless steel 1.4404
- Electrical connection: Round connector M12 x 1, 4-pin

Output signal	Switching mode	Model name	Part no.
1 x PNP	Normally open	MHF15-21NG1PSM	1052237
	Normally closed	MHF15-21NG1HSM	1052273
1 x NPN	Normally open	MHF15-21NG1NSM	1052272
	Normally closed	MHF15-21NG1TSM	1052274

B

Type code

Switch output

P	1 x PNP transistor output, normally closed
N	1 x NPN transistor output, normally closed
H	1 x PNP transistor output, normally open
T	1 x NPN transistor output, normally open

MHF15 - 2 1 N G 1 S M

Dimensional drawing

dimensions in mm (inch)

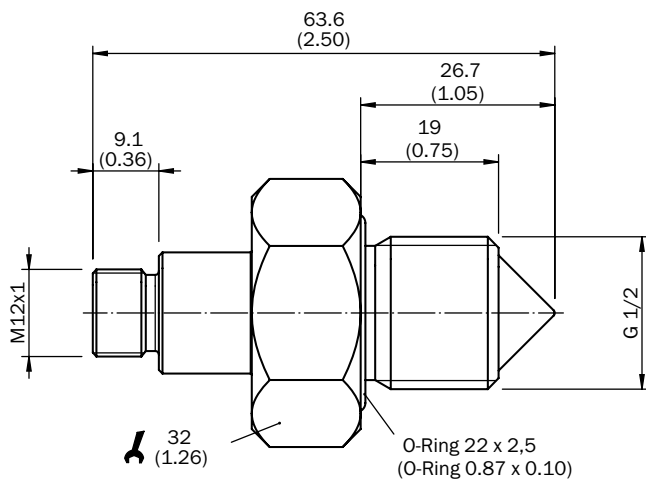

Recommended accessories

Flanges

	Brief description	Model name	Part no.
 Illustration may differ	Welded flange G 1/2	BEF-FL-316G12-LMH1	4065669



The point level sensor for all kinds of liquids



B



Product description

The LFV200 product family tuning forks are universal level sensors that precisely detect pre-defined liquid levels in systems to the millimeter. Regardless of the maximum fill capacity of containers, they can be used as a signal to prevent overfilling, a switching signal for refilling or as a dry-run signal for pump protection. The LFV200 works independently of the liquid. The sturdy stainless steel tuning fork is piezo-electrically energized and vibrates at its resonance frequency. Once the

tuning fork is covered with liquid, the resonance frequency changes. This change is reliably detected and converted into a switching signal. Its high-quality stainless steel surface in combination with the available aseptic process connectors make the LFV200 the sensor of choice in hygienic applications. Thanks to its compact size, it can be mounted even in areas difficult to access. The LFV230 product family also includes tube-extended versions for vertical mounting.

At a glance

- Housing made of 316L stainless steel
- Two electrical output versions available
- Commissioning without filling
- Process temperature up to 150 °C
- Immune to deposit formation
- Very high repeatability
- Aseptic versions with polished surface, CIP and SIP resistant
- Tube extension up to 6 m

Your benefits

- Easy installation and commissioning, no calibration necessary
- Easy operation and integration, saves time
- Maintenance-free sensor, reduces downtime
- Testing in place possible – no mounting required, which reduces installation time
- Flexible and robust system for a multitude of applications
- Universal technology works in all kinds of liquids
- Economical solution for vertical mounting
- Can be used in containers and pipes regardless of the mounting situation



Additional information

- Detailed technical data B-57
- Ordering information B-58
- Type code B-62
- Dimensional drawings B-63
- Recommended accessories B-65

→ www.mysick.com/en/LFV200

For more information, just enter the link or scan the QR code and get direct access to technical data, CAD design models, operating instructions, software, application examples and much more.



Detailed technical data

Features

	LFV200	LFV230
Medium	Fluids	
Measurement	Switch	
Probe length	38 mm 40 mm 117 mm	80 mm ... 6,000 mm
Process pressure	-1 bar ... 64 bar	
Process temperature	-40 °C ... +100 °C -40 °C ... +150 °C	
Fill material density	≥ 0.7 g/cm ³	
WHG approval	Depending on type	
IO-Link	Depending on type	
EHEDG approval	Depending on type	

B

Performance

Accuracy of sensor element	± 2 mm
Repeatability	≤ 1 mm
Viscosity	0.1 mPas ... 10,000 mPas
Resolution	≤ 1 mm
Response time	500 ms

Mechanics

	LFV200	LFV230
Wetted parts	1.4404 (optional Ra < 0.8 μm)	
Process connection	See type code	
Housing material	Stainless steel 1.4404, PEI	

Electronics

	Contactless electronic switch	1 x PNP	1 x PNP with IO-Link
Supply voltage	20 V AC/DC ... 253 V AC/DC	10 V DC ... 55 V DC	
Residual ripple	-	≤ 5 V _{pp}	
Power consumption	≤ 4.2 mA	< 10 mA	
Initialization time	< 3 s	< 2 s	
VDE protection class 1	✓	-	
VDE protection class 2	-	✓	
Electrical connection	Valve plug DIN 43650 Round connector M12 x 1, 4-pin		
Hysteresis	2 mm		
Signal voltage HIGH	-	V _s - 3 V	
Signal voltage LOW	-	0 V ± 1 V	
Output current	< 250 mA		
Inductive load	≤ 1 H		
Capacitive load	100 nF		
Enclosure rating	IP 65 IP 67		
Temperature drift	0.03 mm/K		

Ambient data

Ambient operating temperature	-40 °C ... +70 °C
Ambient storage temperature	-40 °C ... +80 °C

Ordering information

The part numbers below show a selection of our common configurations and represent only a portion of the product portfolio. The type code on page B-62 indicates all possible configurations that can be ordered.

LFV200, electrical connection: Round connector M12 x 1, 4-pin

- **Housing material:** Stainless steel 1.4404, PEI
- **Enclosure rating:** IP 67

B

Process pressure	Process connection	Output signal	Process temperature	Probe length	WHG	Model name	Part no.
-1 bar ... +64 bar	G ¾ A PN 64	1 x PNP	-40 °C ... +100 °C	40 mm	-	LFV200-XXSGBTPM	6036351
					✓	LFV200-XASGBTPM	6036359
				117 mm	-	LFV200-XXSGBTPML	6037457
					✓	LFV200-XASGBTPML	6037458
			-40 °C ... +150 °C	40 mm	-	LFV200-XXTGBTPM	6036355
					✓	LFV200-XATGBTPM	6036363
	117 mm	-	LFV200-XXTGBTPML	6037459			
		✓	LFV200-XATGBTPML	6037460			
	G ½ A PN 64	1 x PNP with IO-Link	-40 °C ... +100 °C	38 mm	-	LFV200-XXSGHIPM	6048862
			-40 °C ... +100 °C	38 mm	-	LFV200-XXSNHIPM	6048863
½" NPT PN 64	1 x PNP with IO-Link	-40 °C ... +100 °C	38 mm	-	LFV200-XXSNHIPM	6048863	
		-40 °C ... +100 °C	38 mm	-	LFV200-XXSNHIPM	6048863	
-1 bar ... +16 bar	Tri-Clamp 1" (PN 16, 316L, Ra < 0.8 µm)	1 x PNP	-40 °C ... +150 °C	40 mm	-	LFV200-XXHCLTPM	6036533
					✓	LFV200-XAHCLTPM	6036538
	Tri-Clamp 2" (PN 16, 316L, Ra 0.8 µm)	1 x PNP	-40 °C ... +150 °C	40 mm	-	LFV200-XXHCNTPM	6036534
					✓	LFV200-XAHCNTPM	6036539
-1 bar ... +40 bar	Conical coupling DN 25 acc. to DIN 11851 with union nut (PN 40, 316L, Ra < 0.8 µm)	1 x PNP	-40 °C ... +150 °C	40 mm	-	LFV200-XXHRLTPM	6036535
					✓	LFV200-XAHLTPM	6036540
	Conical coupling DN 40 acc. to DIN 11851 with union nut (PN 40, 316L, Ra < 0.8 µm)	1 x PNP	-40 °C ... +150 °C	40 mm	-	LFV200-XXHRMTPM	6036536
					✓	LFV200-XAHRMTPM	6036541
	Conical coupling DN 50 acc. to DIN 11851 with union nut (PN 40, 316L, Ra < 0.8 µm)	1 x PNP	-40 °C ... +150 °C	40 mm	-	LFV200-XXHRNTPM	6036537
					✓	LFV200-XAHRNTPM	6036542

LFV200, electrical connection: Valve plug DIN 43650

- **Housing material:** Stainless steel 1.4404, PEI
- **Enclosure rating:** IP 65

Process pressure	Process connection	Output signal	Process temperature	Probe length	WHG	Model name	Part no.	
-1 bar ... +64 bar	G 1 A PN 64	Contactless electronic switch	-40 °C ... +100 °C	40 mm	-	LFV200-XXSGACPV	6036369	
					✓	LFV200-XASGACPV	6036377	
				117 mm	-	LFV200-XXSGACPVL	6037305	
					✓	LFV200-XASGACPVL	6037301	
			-40 °C ... +150 °C	40 mm	-	LFV200-XXTGACPV	6036373	
					✓	LFV200-XATGACPV	6036381	
	117 mm	-	LFV200-XXTGACPVL	6037307				
		✓	LFV200-XATGACPVL	6037303				
	G ¾ A PN 64	Contactless electronic switch	-40 °C ... +100 °C	40 mm	-	LFV200-XXSGBCPV	6036367	
					✓	LFV200-XASGBCPV	6036375	
			-40 °C ... +150 °C	40 mm	-	LFV200-XXTGBCPV	6036371	
	✓	LFV200-XATGBCPV			6036379			
	117 mm	-	LFV200-XXTGBCPVL	6042248				
		G ½ A PN 64	Contactless electronic switch	-40 °C ... +100 °C	40 mm	-	LFV200-XXSGHCPV	6048866
	1" NPT PN 64	Contactless electronic switch	-40 °C ... +100 °C	40 mm	-	LFV200-XXSNACPV	6036370	
					✓	LFV200-XASNACPV	6036378	
				117 mm	-	LFV200-XXSNACPVL	6037306	
					✓	LFV200-XASNACPVL	6037302	
			-40 °C ... +150 °C	40 mm	-	LFV200-XXTNACPV	6036374	
					✓	LFV200-XATNACPV	6036382	
		117 mm	-	LFV200-XXTNACPVL	6037308			
			✓	LFV200-XATNACPVL	6037304			
		¾" NPT PN 64	Contactless electronic switch	-40 °C ... +100 °C	40 mm	-	LFV200-XXSNBCPV	6036368
						✓	LFV200-XASNBCPV	6036376
-40 °C ... +150 °C				40 mm	-	LFV200-XXTNBCPV	6036372	
		✓	LFV200-XATNBCPV		6036380			
½" NPT PN 64	Contactless electronic switch	-40 °C ... +100 °C	40 mm	-	LFV200-XXSNHCPV	6048865		
-1 bar ... +16 bar	Tri-Clamp 1" (PN 16, 316L, Ra<0.8 µm)	Contactless electronic switch	-40 °C ... +150 °C	40 mm	-	LFV200-XXHCLCPV	6036543	
				40 mm	✓	LFV200-XAHCLCPV	6036548	
	Tri-Clamp 2" (PN 16, 316L, Ra<0.8 µm)	Contactless electronic switch		40 mm	-	LFV200-XXHCNCPV	6036544	
				40 mm	✓	LFV200-XAHCNCPV	6036549	
-1 bar ... +40 bar	Conical coupling DN 25 acc. to DIN 11851 with union nut (PN 40, 316L, Ra < 0.8 µm)	Contactless electronic switch	-40 °C ... +150 °C	40 mm	-	LFV200-XXHRLCPV	6036545	
				40 mm	✓	LFV200-XAHRCPV	6036550	
	Conical coupling DN 40 acc. to DIN 11851 with union nut (PN 40, 316L, Ra < 0.8 µm)	Contactless electronic switch		40 mm	-	LFV200-XXHRMCPV	6036546	
				40 mm	✓	LFV200-XAHRMCPV	6036551	
	Conical coupling DN 50 acc. to DIN 11851 with union nut (PN 40, 316L, Ra < 0.8 µm)	Contactless electronic switch		40 mm	-	LFV200-XXHRNCPV	6036547	
				40 mm	✓	LFV200-XAHRNCPV	6036552	

LFV230, electrical connection: Round connector M12 x 1, 4-pin

- **Process connection:** G 3/4 A PN 64
- **Process pressure:** -1 bar ... 64 bar
- **Housing material:** Stainless steel 1.4404, PEI
- **Enclosure rating:** IP 67
- **Output signal:** 1 x PNP

B

Process temperature	Probe length	Model name	Part no.
-40 °C ... +100 °C	200 mm	LFV230-XXSGBTPM0200	6041848
	300 mm	LFV230-XXSGBTPM0300	6041850
	400 mm	LFV230-XXSGBTPM0400	6041852
	500 mm	LFV230-XXSGBTPM0500	6041682
	600 mm	LFV230-XXSGBTPM0600	6041855
	700 mm	LFV230-XXSGBTPM0700	6041857
	800 mm	LFV230-XXSGBTPM0800	6041860
	900 mm	LFV230-XXSGBTPM0900	6041862
	1,000 mm	LFV230-XXSGBTPM1000	6041669
	1,100 mm	LFV230-XXSGBTPM1100	6041864
	1,200 mm	LFV230-XXSGBTPM1200	6041865
	1,300 mm	LFV230-XXSGBTPM1300	6041867
	1,400 mm	LFV230-XXSGBTPM1400	6041870
	1,500 mm	LFV230-XXSGBTPM1500	6041871
	1,600 mm	LFV230-XXSGBTPM1600	6041873
	1,700 mm	LFV230-XXSGBTPM1700	6041875
	1,800 mm	LFV230-XXSGBTPM1800	6041877
	1,900 mm	LFV230-XXSGBTPM1900	6041886
	2,000 mm	LFV230-XXSGBTPM2000	6041887
	-40 °C ... +150 °C	100 mm	LFV230-XXTGBTPM0100
200 mm		LFV230-XXTGBTPM0200	6041903
300 mm		LFV230-XXTGBTPM0300	6041905
400 mm		LFV230-XXTGBTPM0400	6041907
500 mm		LFV230-XXTGBTPM0500	6041909
600 mm		LFV230-XXTGBTPM0600	6041911
700 mm		LFV230-XXTGBTPM0700	6041913
800 mm		LFV230-XXTGBTPM0800	6041915
900 mm		LFV230-XXTGBTPM0900	6041916
1,000 mm		LFV230-XXTGBTPM1000	6041673
1,100 mm		LFV230-XXTGBTPM1100	6041919
1,200 mm		LFV230-XXTGBTPM1200	6041921
1,300 mm		LFV230-XXTGBTPM1300	6041923
1,400 mm		LFV230-XXTGBTPM1400	6041924
1,500 mm		LFV230-XXTGBTPM1500	6041926

Process temperature	Probe length	Model name	Part no.
-40 °C ... +150 °C	1,600 mm	LFV230-XXTGBTPM1600	6041928
	1,700 mm	LFV230-XXTGBTPM1700	6041930
	1,800 mm	LFV230-XXTGBTPM1800	6041933
	1,900 mm	LFV230-XXTGBTPM1900	6041934
	2,000 mm	LFV230-XXTGBTPM2000	6041935
	2,100 mm	LFV230-XXTGBTPM2100	6041936
	2,200 mm	LFV230-XXTGBTPM2200	6041937
	2,300 mm	LFV230-XXTGBTPM2300	6041938
	2,400 mm	LFV230-XXTGBTPM2400	6041939
	2,500 mm	LFV230-XXTGBTPM2500	6041940

B

LFV230, electrical connection: Valve plug DIN 43650

- **Process connection:** G $\frac{3}{4}$ A PN 64
- **Process pressure:** -1 bar ... 64 bar
- **Housing material:** Stainless steel 1.4404, PEI
- **Enclosure rating:** IP 65
- **Output signal:** 1 x PNP
- **Process temperature:** -40 °C ... +100 °C

Probe length	Model name	Part no.
80 mm	LFV230-XXSGBCPV0080	6043182
120 mm	LFV230-XXSGBCPV0120	6043602
300 mm	LFV230-XXSGBCPV0300	6044007
400 mm	LFV230-XXSGBCPV0400	6042265
500 mm	LFV230-XXSGBCPV0500	6044008

Dimensional drawings

dimensions in mm (inch)

Housing (standard temperature range -40 °C ... 100 °C), M12 x 1, IP 67

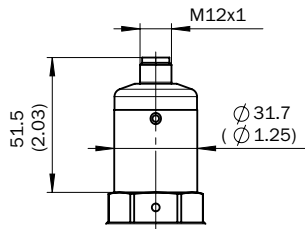

Housing (standard temperature range -40 °C... 100 °C), DIN 43650 incl. plug angled/IP 65

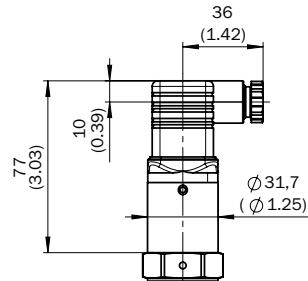

Housing (enhanced temperature range -40 °C ... 150 °C)

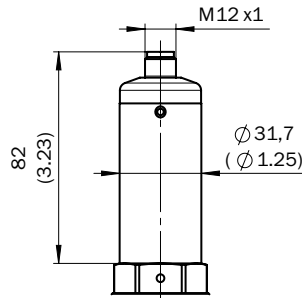

All dimensions in mm (inch)

DIN 11851 DN 25, DN 40, DN 50, M12 x 1/IP 67

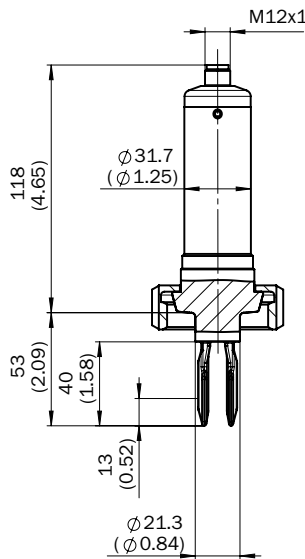

Tri-Clamp 1", 2"

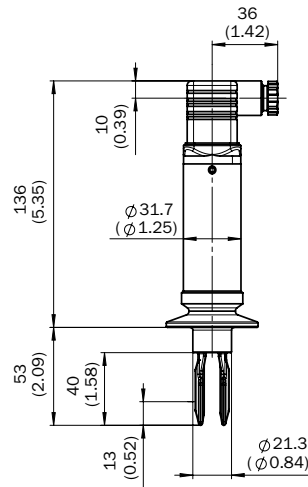

B

G 1 A (probe length 117 mm)

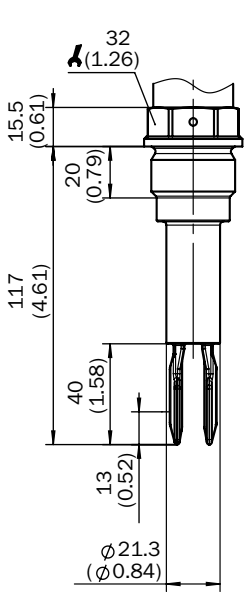

G 1 A, 1" NPT

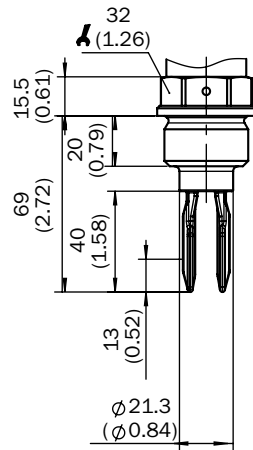

G ¾ A, ¾" NPT

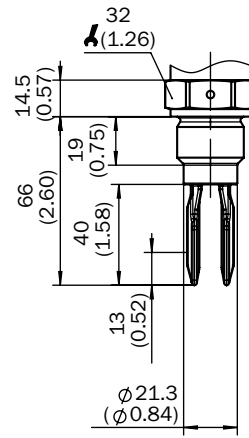

G ½ A, ½" NPT

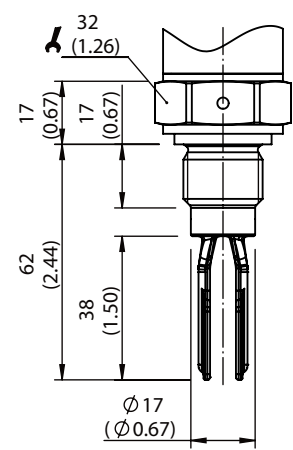

DIN 11851 DN 25, DN 40, DN 50; DIN 43650 incl. plug angled/IP 65

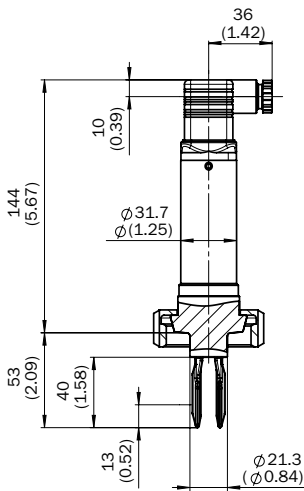

G 1 A, 1" NPT

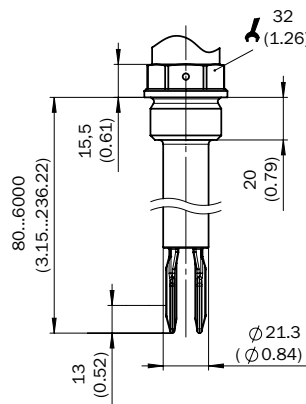



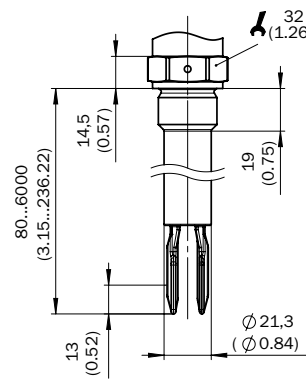

G ¾ A, ¾" NPT



Recommended accessories

Flanges

	Brief description	Model name	Part no.
	Welded flange/welded connector DIN11851-1 DN 25/PN 40	BEF-FL-851D25-LFV2	5321527
	Welded flange/welded connector DIN11851-1 DN 40/PN 40	BEF-FL-851D40-LFV2	5321459
	Welded flange/welded connector DIN11851-1 DN 50/PN 25	BEF-FL-851D50-LFV2	5321528
	Welded flange/welded connector, process connection G 1	BEF-FL-GEWG10-LFV2	4054605
	Welded flange/welded connector, G 3/4 process connection	BEF-FL-GEWG34-LFV2	4054604
	Welded flange/welded connector, process connection Tri-Clamp 1"	BEF-FL-TCLI10-LFV2	5321678
	Welded flange/welded connector, process connection Tri-Clamp 2"	BEF-FL-TCLI20-LFV2	5321679

B

Others

	Brief description	Model name	Part no.
	IO-Link-Master	IOLSHPB-P3104R01	6039728

Flexible and robust in all kinds of liquids



B



Product description

The LFV300 product family of universal vibrating level sensors precisely detect pre-defined liquid levels in systems to the millimeter – even under difficult operating conditions. Regardless of the maximum fill capacity of containers, they can be used as a signal to prevent overfilling, a switching signal for refilling or as a dry-run signal for pump protection. The LFV310 works independently of the liquid and is wear- and maintenance-free. A wide selection of flange, threads and hygienic

connections together with a modular device concept enable customer-specific solutions. The LFV is suitable for hygienic applications and can be cleaned using SIP/CIP. There are also variants for use in explosive atmospheres, to prevent overfilling in compliance with WHG and with GL marine certification. Besides the LFV310 base version, there are LFV330 tube-extended versions for vertical mounting to bridge switching distances up to 6 m.

At a glance

- Several housing materials and electrical outputs available
- Commissioning without filling
- Process temperature up to 250 °C
- Immune to deposit formation
- Very high repeatability
- Aseptic versions according to EHEDG and FDA available, CIP and SIP resistant
- ATEX certification available
- Tube extension up to 6 m

Your benefits

- Easy installation and commissioning, no calibration necessary
- Easy operation and integration, saves time
- Maintenance-free sensor, reduces downtime
- Testing in place possible – no mounting required, which reduces installation time
- Flexible and tough system for a multitude of applications
- Universal technology works in all kinds of liquids



Additional information

Detailed technical data B-67
 Ordering information B-68
 Type code B-71
 Dimensional drawings B-73
 Recommended accessories B-74

→ www.mysick.com/en/LFV300

For more information, just enter the link or scan the QR code and get direct access to technical data, CAD design models, operating instructions, software, application examples and much more.



Detailed technical data

Features

	LFV310	LFV330
Medium	Fluids	
Measurement	Switch	
Probe length	66 mm 117 mm	80 mm ... 6,000 mm
Process pressure	-1 bar ... 64 bar	
Process temperature	-50 °C ... +150 °C -50 °C ... +250 °C	
Fill material density	0.5 g/cm ³ ... 2.5 g/cm ³	
ATEX approval	See type code	
GOST approval	✓	
WHG approval	Depending on type	

Performance

Accuracy of sensor element	± 2 mm
Repeatability	≤ 1 mm
Viscosity	0.1 mPas ... 10,000 mPas
Response time	500 ms

Mechanics

	LFV310	LFV330
Wetted parts	Stainless steel 1.4404 (optional Ra ≤ 0.8 μm)	
Process connection	See type code	
Housing material	Plastic Aluminum Stainless steel (casted) 316L Stainless steel (electropolished)	
Sensor material	Stainless steel 316L	

Electronics

	Contactless electronic switch	Double relay (DPDT)	1 x PNP/NPN	NAMUR signal
Residual ripple	-		≤ 5 V _{pp}	-
Power consumption	< 4.2 mA	5 mA ... 30 mA	< 10 mA	1 mA / 2.5 mA
Initialization time	< 3 s	< 2 s		
VDE protection class 1	✓		-	
VDE protection class 2	-		✓	
Electrical connection	M20 x 1.5 ½" NPT			
Supply voltage	20 V AC/DC ... 253 V AC/DC	20 V DC ... 72 V DC / 20 V AC ... 253 V AC	10 V DC ... 55 V DC	4.5 V DC ... 12 V DC
Hysteresis	2 mm			
Signal voltage HIGH	-		V _S - 3 V	-
Signal voltage LOW	-		< 1 V	-
Output current	< 400 mA	> 10 μA; < 3A AC, 1A DC	< 300 mA	1 mA / 2.5 mA
Inductive load	1 H	750 VA 54 W	1 H	-

	Contactless electronic switch	Double relay (DPDT)	1 x PNP/NPN	NAMUR signal
Capacitive load	100 nF	750 VA 54 W	100 nF	-
Contact load	-	Min. 50 mW/max. 750 VA, 54 W	-	-
Enclosure rating	IP 66 / IP 67			
Temperature drift	0.03 mm/K			

Ambient data

Ambient operating temperature	-40 °C ... +70 °C
Ambient storage temperature	-40 °C ... +80 °C

B

Ordering information

The part numbers below show a selection of our common configurations and represent only a portion of the product portfolio. The type code on page B-71 indicates all possible configurations that can be ordered.

LFV310, process connection: G 1 A PN 64

- Enclosure rating: IP 66 / IP 67
- Process temperature: -50 °C ... +150 °C
- Process pressure: -1 bar ... 64 bar

Output signal	Housing material	Electrical connection	Probe length	ATEX	Model name	Part no.
1 x PNP/NPN	Aluminum	M20 x 1.5	66 mm	✓	LFV310-DAGAVXMTX	6042770
			117 mm	✓	LFV310-DAGAVXMTL	6041729
Double relay (DPDT)	Plastic	½" NPT	66 mm	-	LFV310-XXGAVXNRX	6043567
NAMUR signal	Plastic	M20 x 1.5	66 mm	✓	LFV310-CAGAVXPX	6041542

LFV310, process connection: G ¾ A PN 64

- Enclosure rating: IP 66 / IP 67
- Process temperature: -50 °C ... +150 °C
- Process pressure: -1 bar ... 64 bar
- Electrical connection: M20 x 1.5

Output signal	Housing material	Probe length	ATEX	Model name	Part no.
Double relay (DPDT)	Stainless steel (casted) 316L	66 mm	-	LFV310-XXGBVXVRX	6042787
NAMUR signal		66 mm	✓	LFV310-CAGBVXPX	6042693
		117 mm	✓	LFV310-CAGBVXPNL	6042367

LFV310, process connection: G 3/4 A PN 64 / 1.4404

- **Enclosure rating:** IP 66 / IP 67
- **Process pressure:** -1 bar ... 64 bar
- **Electrical connection:** M20 x 1.5
- **Probe length:** 66 mm

Output signal	Process temperature	Housing material	ATEX	Model name	Part no.
1 x PNP/NPN	-50 °C ... +150 °C	Plastic	-	LFV310-XXGBVXPTX	6037888
		Stainless steel (electropolished)	-	LFV310-XXGBVX8TX	6037752
			✓	LFV310-XAGBVX8TX	6041680
	-50 °C ... +250 °C	Aluminum	-	LFV310-XXGBVXMTX	6037751
		Plastic	-	LFV310-XXGBVTPTX	6037996
		Stainless steel (electropolished)	-	LFV310-XXGBVT8TX	6037995
Aluminum	-		LFV310-XXGBVTMTX	6037994	
Double relay (DPDT)	-50 °C ... +150 °C	Plastic	-	LFV310-XXGBVXPRX	6037993
		Stainless steel (electropolished)	-	LFV310-XXGBVX8RX	6037992
		Aluminum	-	LFV310-XXGBVXMRX	6037991
	-50 °C ... +250 °C	Plastic	-	LFV310-XXGBVTPRX	6038002
		Stainless steel (electropolished)	-	LFV310-XXGBVT8RX	6038001
		Aluminum	-	LFV310-XXGBVTMRX	6038000
Contactless electronic switch	-50 °C ... +150 °C	Plastic	-	LFV310-XXGBVXPCX	6037990
		Stainless steel (electropolished)	-	LFV310-XXGBVX8CX	6037916
		Aluminum	-	LFV310-XXGBVXMCX	6037989
	-50 °C ... +250 °C	Plastic	-	LFV310-XXGBVTPCX	6037999
		Stainless steel (electropolished)	-	LFV310-XXGBVT8CX	6037997
		Aluminum	-	LFV310-XXGBVTMCX	6037998

B

LFV330, process connection: G 1 A PN 64

- **Enclosure rating:** IP 66 / IP 67
- **Process pressure:** -1 bar ... 64 bar
- **Electrical connection:** M20 x 1.5

Output signal	Process temperature	Housing material	Probe length	ATEX	Model name	Part no.
1 x PNP/NPN	-50 °C ... +150 °C	Aluminum	300 mm	-	LFV330-XXGAVXMT0300	6039666
	-50 °C ... +250 °C	Aluminum	750 mm	-	LFV330-XXGAVTMT0750	6040872
Double relay (DPDT)	-50 °C ... +150 °C	Aluminum	900 mm	-	LFV330-XXGAVXMR0900	6039694
			1,300 mm	-	LFV330-XXGAVXMR1300	6039693
			1,600 mm	-	LFV330-XXGAVXMR1600	6039692
			2,000 mm	-	LFV330-XXGAVXMR2000	6039691
			NAMUR signal	-50 °C ... +150 °C	Plastic	550 mm

LFV330, process connection: G 3/4 A PN 64 / 1.4404

- Enclosure rating: IP 66 / IP 67
- Process pressure: -1 bar ... 64 bar
- Electrical connection: M20 x 1.5

Output signal	Process temperature	Housing material	Probe length	ATEX	Model name	Part no.
1 x PNP/NPN	-50 °C ... +150 °C	Stainless steel (electropolished)	100 mm	-	LFV330-XXGBVX8T0100	6039669
		Aluminum	100 mm	-	LFV330-XXGBVXMT0100	6039668
Double relay (DPDT)	-50 °C ... +150 °C	Plastic	200 mm	-	LFV330-XXGBVXPR0200	6039512
			300 mm	-	LFV330-XXGBVXPR0300	6039663
			500 mm	-	LFV330-XXGBVXPR0500	6039661
		Stainless steel (electropolished)	300 mm	-	LFV330-XXGBVX8R0300	6039664
			500 mm	-	LFV330-XXGBVX8R0500	6039662
NAMUR signal	-50 °C ... +250 °C	Aluminum	500 mm	✓	LFV330-DAGBVTMN0500	6042876
Contactless electronic switch	-50 °C ... +150 °C	Plastic	400 mm	-	LFV330-XXGBVXPC0400	6042346
		Aluminum	500 mm	✓	LFV330-DAGBVXMC0500	6039736
	-50 °C ... +250 °C	Stainless steel (casted) 316L	1,000 mm	-	LFV330-XXGBVXVC1000	6043460
		Stainless steel (casted) 316L	200 mm	-	LFV330-XXGBVTVC0200	6043463

B

LFV330, process connection: 3/4" NPT PN 64

- Enclosure rating: IP 66 / IP 67
- Process temperature: -50 °C ... +150 °C
- Process pressure: -1 bar ... 64 bar
- Electrical connection: M20 x 1.5

Output signal	Housing material	Probe length	ATEX	Model name	Part no.
1 x PNP/NPN	Aluminum	500 mm	-	LFV330-XXNBVXMT0500	6039667
	Stainless steel (electropolished)	200 mm	-	LFV330-XXNBVX8T0200	6039670
NAMUR signal	Plastic	300 mm	✓	LFV330-CANBVXPN0300	6042324
Double relay (DPDT)	Plastic	100 mm	-	LFV330-XXNBVXPR0100	6038973

LFV330, process connection: Flange 2" 300lb RF, ANSI B16.5 / 316L

- Enclosure rating: IP 66 / IP 67
- Output signal: NAMUR signal
- Process pressure: -1 bar ... 64 bar
- Housing material: Aluminum
- Electrical connection: M20 x 1.5
- Probe length: 250 mm

Process temperature	ATEX	Model name	Part no.
-50 °C ... +150 °C	✓	LFV330-CAADVXMN0250	6042382
-50 °C ... +250 °C		LFV330-CAADVTMN0250	6042363

LFV330, process connection: Flange 1" 150lb RF, ANSI B16.5 / 316L

- Enclosure rating: IP 66 / IP 67
- Process pressure: -1 bar ... 64 bar
- Electrical connection: M20 x 1.5

Output signal	Process temperature	Housing material	Probe length	ATEX	Model name	Part no.
NAMUR signal	-50 °C ... +150 °C	Plastic	250 mm	✓	LFV330-CAAPVXPN0250	6041550

B

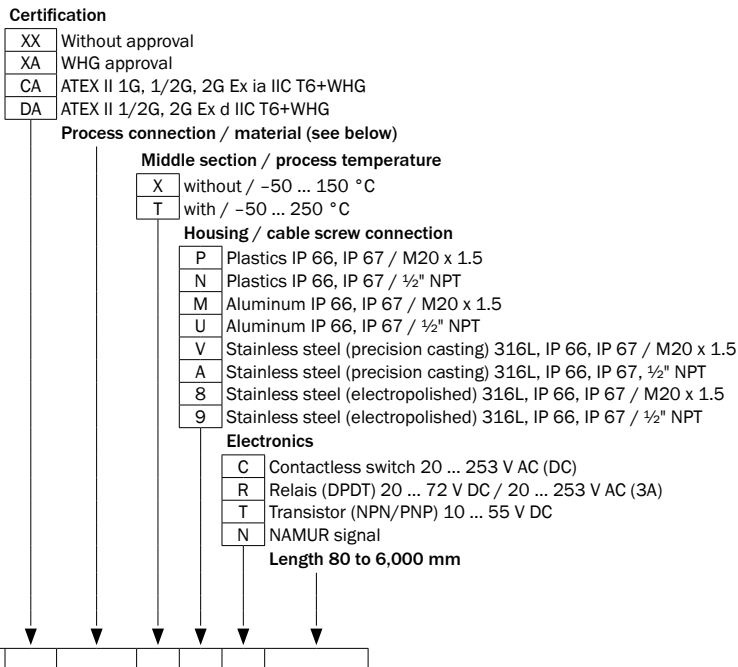

Not all variations of the type code can be combined! Not all available variations are shown.

Process connection / material

GBV	Thread G ¾ A, PN 64 / 316L
GBP	Thread G ¾ A, PN 64 / 316L, Ra < 0.8 µm
NBV	Thread ¾" NPT, PN 64 / 316L
NBP	Thread ¾" NPT, PN 64 / 316L, Ra < 0.8 µm
GAV	Thread G 1 A, PN 64 / 316L
GAP	Thread G 1 A, PN 64 / 316L, Ra < 0.8 µm
NAV	Thread 1" NPT, PN 64 / 316L
NAP	Thread 1" NPT, PN 64 / 316L, Ra < 0.8 µm
GCV	Thread G 1 ½ A, PN 64 / 316L
NCV	Thread 1 ½" NPT, PN 64 / 316L
TAP	Varivent N50-40 / 316L, Ra < 0.8 µm
TNP	Varivent N25-100 / 316L, Ra < 0.8 µm
CCP	Tri-Clamp 1", PN16 / 316L, Ra < 0.8 µm
CBP	Tri-Clamp 1 ½", PN16 / 316L, Ra < 0.8 µm
CAP	Tri-Clamp 2", PN16 / 316L, Ra < 0.8 µm
CDP	Tri-Clamp 2 ½", PN10 / 316L, Ra < 0.8 µm
CEP	Tri-Clamp 3", PN10 / 316L, Ra < 0.8 µm

PLV	Flange, DN 125, PN 40 Form N, DIN 2501 / 316L
FMV	Flange, DN 150, PN 16, Form C, DIN2501 / 316L
MMV	Flange, DN 150, PN 16, Form D, DIN 2501 / 316L
FVV	Flange, DN 150, PN 40, Form C, DIN 2501 / 316L
OVV	Flange, DN 150, PN 40, Form F, DIN 2501 / 316L
PVV	Flange, DN 150, PN 40, Form N, DIN 2501 / 316L
FQV	Flange, DN 200, PN 16, Form C, DIN 2501 / 316L
F5V	Flange, DN 250, PN 10, Form C, DIN 2501 / 316L
UCV	Flange, DN 40, PN 40, V13, DIN 2501 / 316L
FEV	Flange, DN 50, PN 40, Form C, DIN 2501 / 316L
RCP	Fitting, DN 32, PN 40, DIN 11851 / 316L, Ra < 0.8 µm
REP	Fitting, DN 25, PN 40, DIN 11851 / 316L, Ra < 0.8 µm
RAP	Fitting, DN 40, PN 40, DIN 11851 / 316L, Ra < 0.8 µm
RFP	Fitting, DN 40, PN 40, DIN 11864-1A / 316L, Ra < 0.8 µm
RBP	Fitting, DN 50, PN 25, DIN 11851 / 316L, Ra < 0.8 µm
RDP	Fitting, DN 50, PN 25, DIN 11864-1A / 316L, Ra < 0.8 µm

Dimensional drawings

dimensions in mm (inch)

LFV310

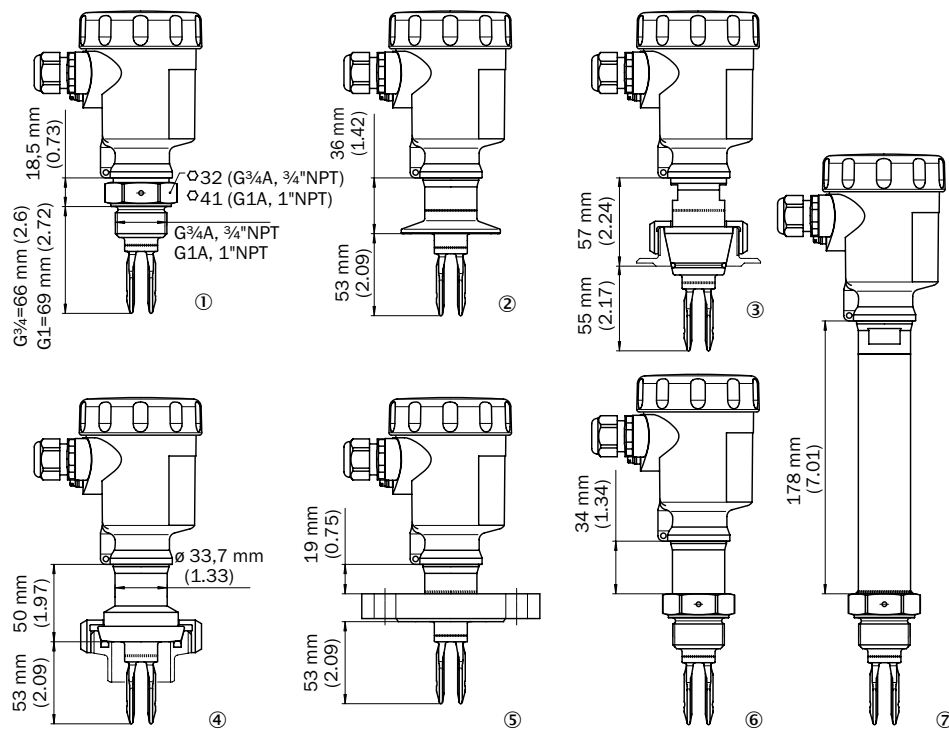

- ① Thread
- ② Tri-Clamp
- ③ Cone DN 25
- ④ Bolting D 25
- ⑤ Flange
- ⑥ Gas-tight leadthrough
- ⑦ Temperature adapter

B

LFV330

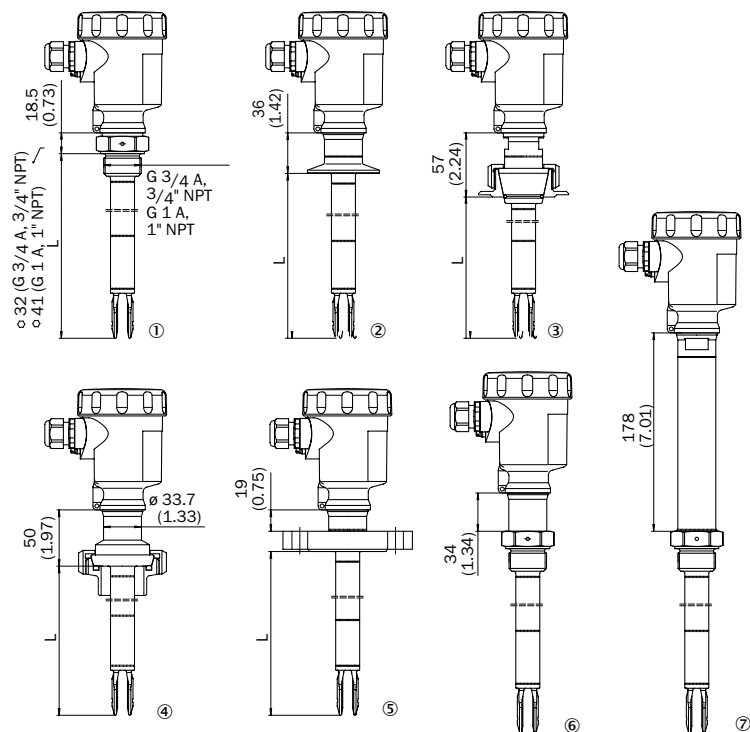

B





- ① Thread
- ② Tri-Clamp
- ③ Cone DN 25
- ④ Bolting D 40
- ⑤ Flange
- ⑥ Gas-tight leadthrough
- ⑦ Temperature adapter

Recommended accessories





Mounting brackets/plates

	Brief description	Model name	Part no.
	Locking screw connection, process pressure – 1 bar ... 64 bar, process connection G 1 A, inner thread G ¾ A	BEF-MU-316G10-ALFV	5322463

Electronic modules

	Brief description	Model name	Part no.
	Contactless electronic switch: 20 V AC/DC ... 250 V AC/DC	ECD-RE-LFVKOS-0001	6038669
	NAMUR signal: 4.5 V DC ... 12 V DC	ECD-RE-LFVNAM-0001	6038670
	Transistor (PNP/NPN): 10 V DC ... 55 V DC	ECD-RE-LFVNP-0001	6038672
	Double relay (DPDT): 20 V DC ... 72 V DC / 20 ... 250 V AC	ECD-RE-LFVREL-0001	6038671

Flanges

	Brief description	Model name	Part no.
	Welded flange/welded connector DIN11851-1 DN 25/PN 40	BEF-FL-851D25-LFV2	5321527
	Welded flange/welded connector, process connection G 1	BEF-FL-GEWG10-LFV2	4054605
	Welded flange/welded connector, G 3/4 process connection	BEF-FL-GEWG34-LFV2	4054604
	Welded flange/welded connector, process connection Tri-Clamp 1"	BEF-FL-TCLI10-LFV2	5321678
	Welded flange/welded connector, process connection Tri-Clamp 2"	BEF-FL-TCLI20-LFV2	5321679

B

Tough and flexible in bulk solids



B



Product description

The rugged, reliable and highly accurate LBV300 product family level sensors signal full, empty, or demand states in bulk solids.

The tuning fork reacts to changes in density, and thus operates independently of silo shape, tank material, container structure or bulk material. The sturdy fork made of stainless steel is oscillated piezo-electrically. The actual resonance of the fork changes significantly when it is covered and triggers a switching signal. With a wide variety of thread

and flange connections and several electronic variants, the LBV series offer a solution for almost all applications, even in potentially explosive atmospheres.

While the LBV310 base version is mainly used to signal full states or mounted laterally, the LBV320 with suspension cable and the LBV330 with tube extension are for vertical mounting to bridge switching distances of up to 80 m or 6 m respectively.

At a glance

- Tough device design
- Several housing materials and electrical outputs available
- Immune to deposit formation
- Commissioning without filling
- Process temperature up to 250 °C
- Very high repeatability
- ATEX versions (1D/2D/1G/2G) available
- Tube-extended version (LBV330) up to 6 m and rope extensions version (LBV320) up to 80 m available for vertical mounting

Your benefits

- Easy installation and commissioning, no calibration necessary
- Easy operation and integration, saves time
- Maintenance-free sensor, reduces downtime
- Testing in place possible – no mounting required, which reduces installation time
- Flexible and tough system for a multitude of applications
- Solutions for vertically mounted switches in difficult installation conditions and surroundings



Additional information

- Detailed technical data B-77
- Ordering information B-78
- Type code B-81
- Dimensional drawings B-84
- Recommended accessories B-85

→ www.mysick.com/en/LBV300

For more information, just enter the link or scan the QR code and get direct access to technical data, CAD design models, operating instructions, software, application examples and much more.



Detailed technical data

Features

	LBV310	LBV320	LBV330
Medium	Bulk solids		
Measurement	Switch		
Probe length	220 mm	480 mm ... 80,000 mm	240 mm ... 6,000 mm
Process pressure	-1 bar ... 25 bar	-1 bar ... 6 bar	-1 bar ... 25 bar
Process temperature	-50 °C ... +150 °C -50 °C ... +250 °C	-20 °C ... +80 °C -40 °C ... +150 °C	-50 °C ... +150 °C -50 °C ... +250 °C
Fill material density	≥ 0.008		
Particle size	< 10 mm		
Tensile strength	-	≤ 3,000 N	-
ATEX approval	See type code		

Performance

Accuracy of sensor element	± 10 mm
Repeatability	≤ 5 mm
Response time	500 ms when covered / 1,000 ms when uncovered

Mechanics

	LBV310	LBV320	LBV330
Process connection	See type code		
Housing material	Plastic Aluminum Stainless steel (casted) 316L Stainless steel (electropolished) 316L		
Sensor material	Stainless steel 316L	Stainless steel 316L, 318S13, PUR, FEP	Stainless steel 316L

Electronics

	Contactless electronic switch	1 x PNP/NPN	Double relay (DPDT)	NAMUR signal
Residual ripple	-	≤ 5 V _{pp}	-	-
Power consumption	< 4.2 mA	< 10 mA	5 mA ... 30 mA	1 mA / 2.5 mA
Initialization time	< 3 s	< 2 s		
VDE protection class 1	✓	-	✓	-
VDE protection class 2	-	✓	-	✓
Electrical connection	M20 x 1.5 ½" NPT			
Supply voltage	20 V AC/DC ... 253 V DC	10 V DC ... 55 V DC	20 V DC ... 72 V DC / 20 V AC ... 253 V AC	4.5 V DC ... 12 V DC
Hysteresis	10 mm			
Signal voltage HIGH	-	V _s -3 V	-	
Signal voltage LOW	-	< 1 V		
Output current	< 400 mA	< 300 mA	> 10 μA; < 3A AC, 1A DC	1 mA / 2.5 mA

	Contactless electronic switch	1 x PNP/NPN	Double relay (DPDT)	NAMUR signal
Inductive load	≤ 1 H		750 VA 54 W	
Capacitive load	100 nF		750 VA 54 W	
Contact load	-	Min. 50 mW/max. 750 VA, 54 W	-	
Enclosure rating	IP 66 / IP 67			

Ambient data

Ambient operating temperature	-40 °C ... +70 °C
Ambient storage temperature	-40 °C ... +80 °C

B

Ordering information

The part numbers below show a selection of our common configurations and represent only a portion of the product portfolio. The type code on page B-81 indicates all possible configurations that can be ordered.

LBV310

- Enclosure rating: IP 66 / IP 67
- Process connection: G 1 ½ A PN 25
- Process pressure: -1 bar ... 25 bar
- Probe length: 220 mm

Output signal	Process temperature	Housing material	Electrical connection	ATEX	Model name	Part no.	
1 x PNP/NPN	-50 °C ... +150 °C	Aluminum	M20 x 1.5	✓	LBV310-GXAGDTAEX	6041439	
					LBV310-GXAGDTAMX	6042031	
		Stainless steel (casted) 316L	M20 x 1.5	✓	LBV310-LKAGDTVMX	6039277	
		Plastic	M20 x 1.5	-	LBV310-XXAGDTKMX	6038016	
					LBV310-XXCGDTKMX	6038112	
					LBV310-XXAGDTKCX	6039060	
	LBV310-XXAGDTKNX				6038019		
	-50 °C ... +250 °C	Plastic	-	LBV310-XXCGDTKNX	6038115		
				M20 x 1.5	-	LBV310-XXBGDTKMX	6038064
				½" NPT	-	LBV310-XXBGDTKNX	6038067
Double relay (DPDT)	-50 °C ... +150 °C	Stainless steel (casted) 316L	M20 x 1.5	✓	LBV310-LKAGDRVMX	6039276	
		Plastic	M20 x 1.5	-	LBV310-XXAGDRKMX	6038011	
					LBV310-XXCGDRKMX	6038106	
					✓	LBV310-LXAGDRKMX	6042635
					LBV310-XXAGDRKNX	6038013	
		-50 °C ... +250 °C	Plastic	-	LBV310-XXCGDRKNX	6038109	
	M20 x 1.5				-	LBV310-XXBGDRKMX	6038058
	½" NPT				-	LBV310-XXBGDRKNX	6038061
	Contactless electronic switch	-50 °C ... +150 °C	Aluminum	M20 x 1.5	✓	LBV310-GXCGDCAMX	6041552
Plastic			M20 x 1.5	-	LBV310-XXAGDCKMX	6038006	
					LBV310-XXCGDCKMX	6038100	
					LBV310-XXAGDCKNX	6038008	
-50 °C ... +250 °C		Plastic	-	LBV310-XXCGDCKNX	6038103		
				M20 x 1.5	-	LBV310-XXBGDCKMX	6038052
				½" NPT	-	LBV310-XXBGDCKNX	6038055

Output signal	Process temperature	Housing material	Electrical connection	ATEX	Model name	Part no.
NAMUR signal	-50 °C ... +150 °C	Plastic	M20 x 1.5	-	LBV310-XXAGDNKMX	6038022
					LBV310-XXCGDNKMX	6038118
			½" NPT	-	LBV310-XXAGDNKNX	6038025
					LBV310-XXCGDNKNX	6038121
	-50 °C ... +250 °C	Plastic	M20 x 1.5	-	LBV310-XXBGDNKMX	6038070
					½" NPT	-

LBV320

- **Enclosure rating:** IP 66 / IP 67
- **Process connection:** G 1 ½ A PN 25
- **Output signal:** Double relay (DPDT)
- **Process temperature:** -20 °C ... +80 °C
- **Process pressure:** -1 bar ... 6 bar
- **Housing material:** Aluminum
- **Electrical connection:** M20 x 1.5

B

Probe length	ATEX	Model name	Part no.
500 mm	-	LBV320-XXTGDRAMX00500	6038395
600 mm	-	LBV320-XXTGDRAMX00600	6038396
700 mm	-	LBV320-XXTGDRAMX00700	6038397
800 mm	-	LBV320-XXTGDRAMX00800	6038398
900 mm	-	LBV320-XXTGDRAMX00900	6038399
1,000 mm	-	LBV320-XXTGDRAMX01000	6038400
1,100 mm	-	LBV320-XXTGDRAMX01100	6038401
1,200 mm	-	LBV320-XXTGDRAMX01200	6038402
1,300 mm	-	LBV320-XXTGDRAMX01300	6038403
1,400 mm	-	LBV320-XXTGDRAMX01400	6038404
1,500 mm	-	LBV320-XXTGDRAMX01500	6038405
1,600 mm	-	LBV320-XXTGDRAMX01600	6038406
1,700 mm	-	LBV320-XXTGDRAMX01700	6038407
1,800 mm	-	LBV320-XXTGDRAMX01800	6038408
1,900 mm	-	LBV320-XXTGDRAMX01900	6038409
2,000 mm	-	LBV320-XXTGDRAMX02000	6038410
2,100 mm	-	LBV320-XXTGDRAMX02100	6038411
2,200 mm	-	LBV320-XXTGDRAMX02200	6038412
2,300 mm	-	LBV320-XXTGDRAMX02300	6038413
2,400 mm	-	LBV320-XXTGDRAMX02400	6038414
2,500 mm	-	LBV320-XXTGDRAMX02500	6038415
2,600 mm	-	LBV320-XXTGDRAMX02600	6038416
2,700 mm	-	LBV320-XXTGDRAMX02700	6038417
2,800 mm	-	LBV320-XXTGDRAMX02800	6038418
2,900 mm	-	LBV320-XXTGDRAMX02900	6038419
3,000 mm	-	LBV320-XXTGDRAMX03000	6038420

LBV300

- Enclosure rating: IP 66 / IP 67
- Process connection: G 1 ½ A PN 25
- Output signal: Double relay (DPDT)
- Process pressure: -1 bar ... 25 bar
- Housing material: Aluminum

Process temperature	Electrical connection	Probe length	ATEX	Model name	Part no.
-50 °C ... +150 °C	½" NPT	240 mm	-	LBV330-XXAGDRANX0240	6038148
		300 mm	-	LBV330-XXAGDRANX0300	6038149
		400 mm	-	LBV330-XXAGDRANX0400	6038150
		500 mm	-	LBV330-XXAGDRANX0500	6038151
		600 mm	-	LBV330-XXAGDRANX0600	6038152
		700 mm	-	LBV330-XXAGDRANX0700	6038153
		800 mm	-	LBV330-XXAGDRANX0800	6038154
		900 mm	-	LBV330-XXAGDRANX0900	6038155
		1,000 mm	-	LBV330-XXAGDRANX1000	6038156
		1,100 mm	-	LBV330-XXAGDRANX1100	6038157
		1,200 mm	-	LBV330-XXAGDRANX1200	6038158
		1,300 mm	-	LBV330-XXAGDRANX1300	6038159
		1,400 mm	-	LBV330-XXAGDRANX1400	6038160
		1,500 mm	-	LBV330-XXAGDRANX1500	6038161
		1,600 mm	-	LBV330-XXAGDRANX1600	6038162
		1,700 mm	-	LBV330-XXAGDRANX1700	6038163
		1,800 mm	-	LBV330-XXAGDRANX1800	6038164
		1,900 mm	-	LBV330-XXAGDRANX1900	6038165
		2,000 mm	-	LBV330-XXAGDRANX2000	6038166
		2,100 mm	-	LBV330-XXAGDRANX2100	6038167
2,200 mm	-	LBV330-XXAGDRANX2200	6038168		
2,300 mm	-	LBV330-XXAGDRANX2300	6038169		
2,400 mm	-	LBV330-XXAGDRANX2400	6038170		
2,500 mm	-	LBV330-XXAGDRANX2500	6038171		
-50 °C ... +250 °C	M20 x 1.5	300 mm	-	LBV330-XXBGDRAMX0300	6038293
		400 mm	-	LBV330-XXBGDRAMX0400	6038294
		500 mm	-	LBV330-XXBGDRAMX0500	6038295
		600 mm	-	LBV330-XXBGDRAMX0600	6038296
		700 mm	-	LBV330-XXBGDRAMX0700	6038297
		800 mm	-	LBV330-XXBGDRAMX0800	6038298
		900 mm	-	LBV330-XXBGDRAMX0900	6038299
		1,000 mm	-	LBV330-XXBGDRAMX1000	6038300
		1,100 mm	-	LBV330-XXBGDRAMX1100	6038301
		1,200 mm	-	LBV330-XXBGDRAMX1200	6038302
1,300 mm	-	LBV330-XXBGDRAMX1300	6038303		

B

Certification

XX	without
CX	ATEX II 1G, 1/2G, 2G Ex ia IIC T6
CK	ATEX II 1G, 1/2G, 2G Ex ia IIC T6+ATEX II 1/2D IP6X T
GX	ATEX II 1/2D IP6X T

Complexion / process temperature

C	Cable PUR, detection of solids in water / -20 ... 80 °C
H	Cable FEP / -40 ... 150 °C
T	Cable PUR / -20 ... 80 °C

Process connection / material

XX	without / 316L
GD	Thread G 1 ½ A, PN 16 / 316L
ND	Thread 1 ½" NPT, PN 16 / 316L
EF	Flange DN 50, PN 40, Form C, DIN 2501 / 316L
KF	Flange DN 80, PN 40, Form C, DIN 2501 / 316L
ZF	Flange DN 100, PN 6, Form C, DIN 2501 / 316L
MF	Flange DN 100, PN 16, Form C, DIN 2501 / 316L
OF	Flange DN 100, PN 40, Form C, DIN 2501 / 316L
QF	Flange DN 150, PN 16 Form C, DIN 2501 / 316L
2F	Flange DN 200, PN 10, Form C, DIN 2501 / 316L
EK	Flange DN 50, PN 40, EN 1092-1, Form B1 / 316L
HA	Flange 2", 150lb RF, ANSI B16.5 / 316L
HE	Flange 2", 150lb FF, ANSI B16.5 / 316L
IA	Flange 2", 300lb RF, ANSI B16.5 / 316L
OA	Flange 3", 150lb RF, ANSI B16.5 / 316L
OE	Flange 3", 150lb FF, ANSI B16.5 / 316L
PA	Flange 3", 300lb RF, ANSI B16.5 / 316L
JA	Flange 3 ½", 150lb RF, ANSI B16.5 / 316L
SA	Flange 4", 150lb RF, ANSI B16.5 / 316L
UA	Flange 4", 300lb RF, ANSI B16.5 / 316L
AU	Flange DN 50, 10K RF, JIS / 316L
BU	Flange DN 80, 10K RF, JIS / 316L
CU	Flange DN 100, 10K RF, JIS / 316L

Electronic

C	Contactless switch 20 ... 253 V AC (DC)
R	Relay (DPDT) 20 ... 72 V DC / 20 ... 253 V AC (3A)
T	Transistor output (NPN/PNP) 10 ... 55 V DC
N	NAMUR-output

Housing / protection class

K	Plastic / IP 66, IP 67
A	Aluminum / IP 66, IP 67
V	Stainless steel (precision casting) 316L / IP 66, IP 67
8	Stainless steel (electropolished) 316L / IP 66, IP 67

Cable entry / plug connection

M	M20 x 1.5 / without
N	½" NPT / without

Length 480 to max. 80,000 mm



Not all variations of the type code can be combined!

Certification

XX	without
CX	ATEX II 1G, 1/2G, 2G Ex ia IIC T6
CK	ATEX II 1G, 1/2G, 2G Ex ia IIC T6+ATEX II 1/2D IP6X T
LX	ATEX II 1G, 1/2G, 2G Ex d IIC T6
LK	ATEX II 1/2G, 2G Ex d IIC T6+ATEX II 1/2D, 2D IP6X
GX	ATEX II 1/2D IP6X T

Complexion/ process temperatur

A	Standard / -50 ... 150 °C
B	with middle section / -50 ... 250 °C
C	Detection of solids in water / -50 ... 150 °C

Process connection / material

GD	Thread G 1 ½ A, PN 25 / 316L
ND	Thread 1 ½" NPT, PN 25 / 316L
EF	Flange DN 50, PN 40, Form C, DIN 2501 / 316L
KF	Flange DN 80, PN 40, Form C, DIN 2501 / 316L
ZF	Flange DN 100, PN 6, Form C, DIN 2501 / 316L
MF	Flange DN 100, PN 16, Form C, DIN 2501 / 316L
OF	Flange DN 100, PN 40, Form C, DIN 2501 / 316L
QF	Flange DN 150, PN 16, Form C, DIN 2501 / 316L
2F	Flange DN 200, PN 10, Form C, DIN 2501 / 316L
EK	Flange DN 50, PN 40, EN 1092-1, Form B1 / 316L
HA	Flange 2", 150lb RF, ANSI B16.5 / 316L
HE	Flange 2", 150lb FF, ANSI B16.5 / 316L
IA	Flange 2", 300lb RF, ANSI B16.5 / 316L
OA	Flange 3", 150lb RF, ANSI B16.5 / 316L
OE	Flange 3", 150lb FF, ANSI B16.5 / 316L
PA	Flange 3", 300lb RF, ANSI B16.5 / 316L
JA	Flange 3 ½", 150lb RF, ANSI B16.5 / 316L
SA	Flange 4", 150lb RF, ANSI B16.5 / 316L
UA	Flange 4", 300lb RF, ANSI B16.5 / 316L
AU	Flange DN 50, 10K RF, JIS / 316L
BU	Flange DN 80, 10K RF, JIS / 316L
CU	Flange DN 100, 10K RF, JIS / 316L

Electronic

C	Contactless switch 20 ... 253 V AC (DC)
R	Relay (DPDT) 20 ... 72 V DC / 20 ... 253 V AC (3A)
T	Transistor output (NPN/PNP) 10 ... 55 V DC
N	NAMUR-output

Housing / protection class

K	Plastic / IP 66, IP 67
A	Aluminum / IP 66, IP 67
V	Stainless steel (precision casting) 316L / IP 66, IP 67
8	Stainless steel (electropolished) 316L / IP 66, IP 67

Cable entry / plug connection

M	M20 x 1.5 / without
N	½" NPT / without

Length 240 to 6,000 mm



Not all variations of the type code can be combined!

B

Dimensional drawings

dimensions in mm (inch)

B

Temperature adapter

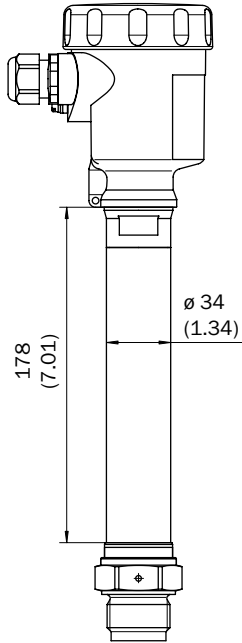

LBV310 threaded version G 1 ½ A (DIN ISO 228/1)

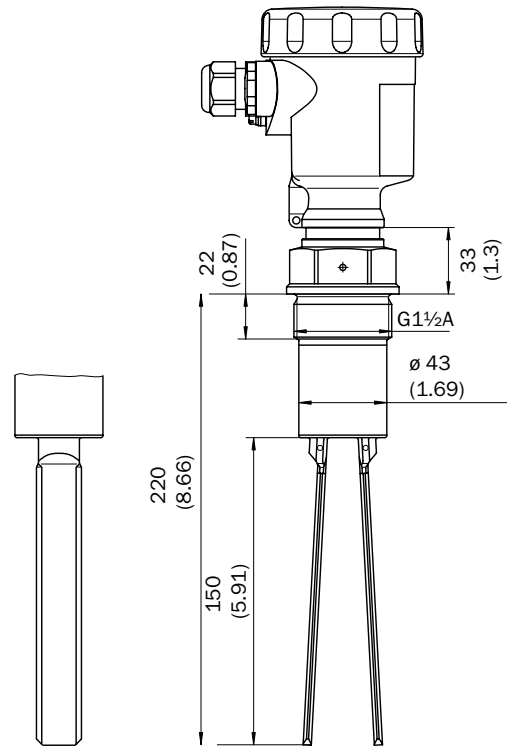

LBV320 with PUR suspension cable, threaded version G 1 ½ A (DIN ISO 228/1)

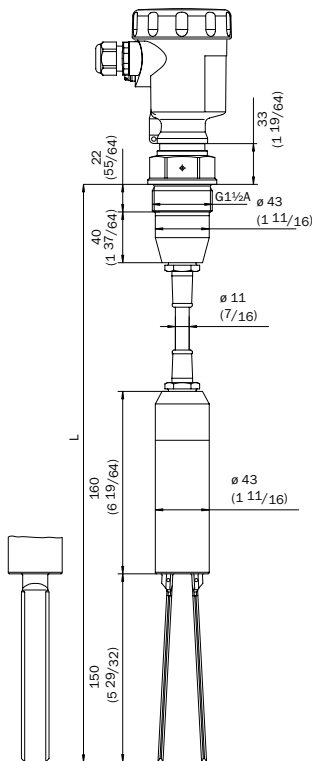

LBV330 threaded version G 1 ½ A (DIN ISO 228/1)

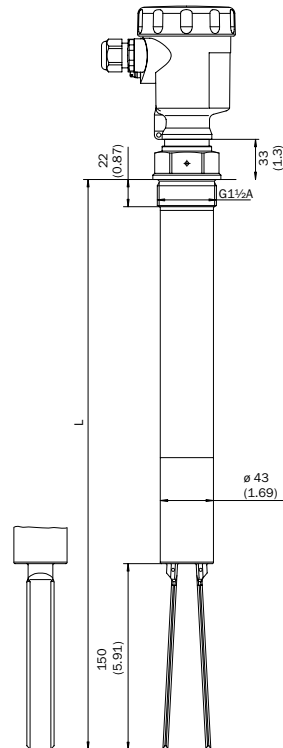





Recommended accessories

Mounting brackets/plates

	Brief description	Model name	Part no.
	Locking screw connection, process pressure –1 bar to 16 bar, process connection G 2 A, inner thread G 1 ½ A	BEF-MU-316G20-ALBV	5322462

Electronic modules

	Brief description	Model name	Part no.
	Contactless electronic switch: 20 V AC/DC ... 250 V AC/DC	ECD-RE-LBVKOS-0001	6038665
	NAMUR signal: 4.5 V DC ... 12 V DC	ECD-RE-LBVNAM-0001	6038668
	Transistor (PNP/NPN): 10 V DC ... 55 V DC	ECD-RE-LBVPNP-0001	6038667
	Double relay (DPDT): 20 V DC ... 72 V DC / 20 ... 250 V AC	ECD-RE-LBVREL-0001	6038666

B

Rugged, flexible and cleanable



B

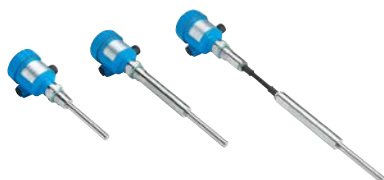

Product description

The LBV family of level sensors features a vibrating fork sensor that provides overflow or dry-run signals for containers with bulk or powdered materials. The reliable and accurate LBV301 level sensors signal full, empty or demand states. The rugged, stainless steel sensor design prevents bulk materials from jamming. When the probe is covered with bulk material, the changing vibration amplitude is reliably detected and converted into a switching signal. In addition, the LBV301 features an easy-to-clean monoprobe that is

immune to contamination, making it suitable for use in the food industry. While the LBV311 base version is mainly mounted horizontally, the LBV321 with a suspension cable and the LBV331 with a tube extension are mounted vertically to bridge switching distances of up to 80 m or 6 m respectively. With a variety of process connections for hygienic applications, and several output options, the LBV301 can be used for nearly all applications, even in explosive atmospheres.

At a glance

- Compact sensor from 1" thread
- Monoprobe design prevents bulk materials from sticking and jamming
- Polished monoprobe for food applications
- Commissioning without filling
- Process temperature up to 250 °C
- ATEX versions (1D/2D/1G/2G) available
- Tube-extended version (LBV331) up to 6 m and rope-extended version (LBV321) up to 80 m available for vertical mounting

Your benefits

- Easy commissioning and no calibration reduce setup time
- Maintenance-free sensor, reduces downtime
- On-site testing – no mounting required, which reduces setup time
- Flexible and rugged system suitable for many types of applications
- Vertical mounting in difficult installation conditions



Additional information

- Detailed technical data. B-87
- Ordering information. B-88
- Type code. B-89

→ www.mysick.com/en/LBV301

For more information, just enter the link or scan the QR code and get direct access to technical data, CAD design models, operating instructions, software, application examples and much more.



Detailed technical data

Features

	LBV311	LBV321	LBV331
Medium	Bulk solids		
Measurement	Switch		
Probe length	160 mm	480 mm ... 80,000 mm	180 mm ... 6,000 mm
Process pressure	-1 bar ... 16 bar	-1 bar ... 6 bar	-1 bar ... 16 bar
Process temperature	-50 °C ... +150 °C	-0 °C ... +80 °C -40 °C ... 150 °C	-50 °C ... +150 °C
Fill material density	≥ 0.02 g/cm ³		
Tensile strength	-	≤ 3,000 N	-
WHG approval	See type code		

Performance

Accuracy of sensor element	± 10 mm
Repeatability	≤ 5 mm
Response time	500 ms when covered / 1,000 ms when uncovered

Mechanics

	LBV311	LBV321	LBV331
Process connection	See type code		
Housing material	Plastic Aluminum Stainless steel (casted) 316L Stainless steel (electropolished) 316L		
Sensor material	Stainless steel 316L, 318S	Stainless steel 316L, 318S, PUR, FEB	Stainless steel 316L, 318S

Electronics

	Contactless electronic switch	Double relay (DPDT)	1 x PNP/NPN	NAMUR signal
Residual ripple	-	-	≤ 5 V _{pp}	-
Power consumption	< 4.2 mA	5 mA ... 30 mA	≤ 10 mA	1 mA / 2.5 mA
Initialization time	< 3 s	< 2 s	-	-
VDE protection class 1	✓	-	-	-
VDE protection class 2	-	-	✓	-
Electrical connection	M20 x 1.5 ½" NPT			
Supply voltage	20 V AC/DC ... 253 V DC	20 V DC ... 72 V DC / 20 V AC ... 253 V AC	10 V DC ... 55 V DC	4.5 V DC ... 12 V DC
Hysteresis	10 mm			
Signal voltage HIGH	-	-	V _S - 3 V	-
Signal voltage LOW	-	-	< 1 V	-
Output current	< 400 mA	> 10 µA; < 3A AC, 1A DC	< 300 mA	1 mA / 2.5 mA
Inductive load	1 H	-	1 H	-
Capacitive load	100 nF	-	100 nF	-
Enclosure rating	IP 66 / IP 67			

Ambient data

Ambient operating temperature	-40 °C ... +70 °C
Ambient storage temperature	-40 °C ... +80 °C

Ordering information

The part numbers below show a selection of our common configurations and represent only a portion of the product portfolio. The type code on page B-89 indicates all possible configurations that can be ordered.

LBV311

- Enclosure rating: IP 66 / IP 67
- Process connection: G 1 A
- Process temperature: -50 °C ... +150 °C
- Process pressure: -1 bar ... 16 bar
- Housing material: Plastic
- Electrical connection: M20 x 1.5
- Probe length: 160 mm

Output signal	ATEX	Model name	Part no.
NAMUR signal	-	LBV311-XXAGCNKMX	6044866
Contactless electronic switch	-	LBV311-XXAGCCKMX	6044863
Double relay (DPDT)	-	LBV311-XXAGCRKMX	6044864
1 x PNP/NPN	-	LBV311-XXAGCTKMX	6044865

LBV321

- Enclosure rating: IP 66 / IP 67
- Process connection: G 1 A
- Process temperature: -20 °C ... +80 °C
- Process pressure: -1 bar ... 6 bar
- Housing material: Plastic
- Electrical connection: M20 x 1.5
- Probe length: 1,000 mm

Output signal	ATEX	Model name	Part no.
NAMUR signal	-	LBV321-XXTGCKMX01000	6044871
Contactless electronic switch	-	LBV321-XXTGCCMX01000	6044868
Double relay (DPDT)	-	LBV321-XXTGCRMX01000	6044869
1 x PNP/NPN	-	LBV321-XXTGCTMX01000	6044870

LBV331

- Enclosure rating: IP 66 / IP 67
- Process connection: G 1 A
- Process temperature: -50 °C ... +150 °C
- Process pressure: -1 bar ... 16 bar
- Housing material: Plastic
- Electrical connection: M20 x 1.5
- Probe length: 1,000 mm

Output signal	ATEX	Model name	Part no.
NAMUR signal	-	LBV331-XXAGCNKMX01000	6044877
Contactless electronic switch	-	LBV331-XXAGCCKMX01000	6044874
Double relay (DPDT)	-	LBV331-XXAGCRMX01000	6044875
1 x PNP/NPN	-	LBV331-XXAGCTMX01000	6044876

Certification

XX	without
CX	ATEX II 1G, 1/2G, 2G Ex ia IIC T6
CK	ATEX II 1G, 1/2G, 2G Ex ia IIC T6 + 1D, 1/2D, 2D Ex tD IP66 T
LX	ATEX II 1/2G, 2G Ex d IIC T6
LK	ATEX II 1/2G, 2G Ex d IIC T6 + 1D, 1/2D, 2D Ex tD IP66 T
GX	ATEX II 1D, 1/2D, 2D Ex tD IP66 T

Complexion / process temperature

A	Standard / -50 ... 150 °C
B	with middle section / -50 ... 250 °C
C	Detection of solids in water / -50 ... 150 °C

Process connection / material (see below)

Electronic

C	Contactless switch 20 ... 253 V AC (DC)
R	Relay (DPDT) 20 ... 72 V DC/20 ... 253 V AC (3A)
T	Transistor output (NPN/PNP) 10 ... 55 V DC
N	NAMUR-output

Housing / protection class

K	Plastic / IP 66, IP 67
A	Aluminum / IP 66, IP 67
V	Stainless steel (precision casting) 316L / IP 66, IP 67
8	Stainless steel (electropolished) 316L / IP 66, IP 67

Cable entry / plug connection

M	M20 x 1.5 / without
N	½" NPT / without

Length 180 to 6,000 mm



Not all variations of the type code can be combined!

Process connection / material

GC	Thread G 1, DIN 3852-A, PN 6 / 316L
GR	Thread G 1, DIN 3852-A, PN 6 / 316L, Ra < 0.8 µm
GD	Thread G 1 ½, DIN 3852-A, PN 16 / 316L
GT	Thread G 1 ½, DIN 3852-A, PN 16 / 316L, Ra < 0.8 µm
ND	Thread 1 ½" NPT, ASME B1.20.1, PN 16 / 316L
NT	Thread 1 ½" NPT, ASME B1.20.1, PN 16 / 316L, Ra < 0.8 µm
CT	Tri-Clamp 1 ½" / 316L, Ra < 0.8 µm
CV	Tri-Clamp 2" / 316L, Ra < 0.8 µm
CQ	Tri-Clamp 2 ½" / 316L, Ra < 0.8 µm
CM	Tri-Clamp 3 ½" / 316L, Ra < 0.8 µm
RP	Fitting DN 40 PN 40 DIN 11851 / 316L, Ra < 0.8 µm
RF	Fitting DN 40 PN 40 DIN 11864-1 Form A / 316L, Ra < 0.8 µm
RH	Fitting DN 65 PN 25 DIN 11851 / 316L, Ra < 0.8 µm
TV	Tuchenhagen Varivent DN 32, 1 ½" .. PN 25 / 316L, Ra < 0.8 µm
C2	Terminal DN 40 PN 40 DIN 11864-3 Form A / 316L, Ra < 0.8 µm
BF	Flange DN 32 PN 40 Form C, DIN 2501 / 316L
DF	Flange DN 40 PN 40 Form C, DIN 2501 / 316L
EF	Flange DN 50 PN 40 Form C, DIN 2501 / 316L
4F	Flange DN 65 PN 16 Form C, DIN 2501 / 316L
KF	Flange DN 80 PN 40 Form C, DIN 2501 / 316L
ZF	Flange DN 100 PN 6 Form C, DIN 2501 / 316L

MF	Flange DN 100 PN 16 Form C, DIN 2501 / 316L
OF	Flange DN 100 PN 40 Form C, DIN 2501 / 316L
3F	Flange DN 125 PN 6 Form C, DIN 2501 / 316L
QF	Flange DN 150 PN 16 Form C, DIN 2501 / 316L
2F	Flange DN 200 PN 10 Form C, DIN 2501 / 316L
EK	Flange DN 50 PN 40 EN1092-1 Form B1 / 316L
DA	Flange 1 ½" 150lb RF, ANSI B16.5 / 316L
EA	Flange 1 ½" 300lb RF, ANSI B16.5 / 316L
HA	Flange 2" 150lb RF, ANSI B16.5 / 316L
IA	Flange 2" 300lb RF, ANSI B16.5 / 316L
OA	Flange 3" 150lb RF, ANSI B16.5 / 316L
OE	Flange 3" 150lb FF, ANSI B16.5 / 316L
PA	Flange 3" 300lb RF, ANSI B16.5 / 316L
PE	Flange 3" 300lb FF, ANSI B16.5 / 316L
JA	Flange 3 ½" 150lb RF, ANSI B16.5 / 316L
SA	Flange 4" 150lb RF, ANSI B16.5 / 316L
UA	Flange 4" 300lb RF, ANSI B16.5 / 316L
AU	Flange DN 50 10K RF, JIS / 316L
HU	Flange DN 50 10K RF, JIS / 316L
BU	Flange DN 80 10K RF, JIS / 316L
CU	Flange DN 100 10K RF, JIS / 316L

C

Robust and precise – flow measurement technology from SICK

SICK provides innovative sensor solutions for flow measurement technology which combine flexible measuring methods and robust equipment design with cost-efficient connection concepts for higher-order systems. Whether you need to detect the current flow rate using analog values or find the quantity using pulse detection – SICK's flow sensors are always reliable and safe for a wide range of media and under difficult process and ambient conditions.

Your benefits

- High system availability due to non-contact, robust sensor concepts
- Maintenance-free sensors reduce the total cost of ownership
- Cost savings due to multiple output signals from one sensor – on both the sensor side and the control side
- Universal measuring devices thanks to product-independent sensor technology
- Compact designs allow simple installation even in tight mounting situations



C

Flow sensors

General information	C-94
Product family overview	C-97



FFU	C-98
Non-contact flow measurement	



Bulkscan® LMS511	C-106
Non-contact and maintenance-free sensor for measuring volume flow	



Flow and throughput measurement with modern technology

SICK's flow meters combine innovative, real-time measurements based on ultrasonic and laser technology. These non-contact technologies are particularly ideal for their flexibility in a wide range of applications.



C

Reliable bulk material detection



Bulk materials



Continuous measurement of bulk material throughput is often affected not only by standard technical challenges, but also by very difficult ambient conditions. Non-contact measuring systems from SICK, based on time-of-flight, can be used to generate low-maintenance, efficient systems.

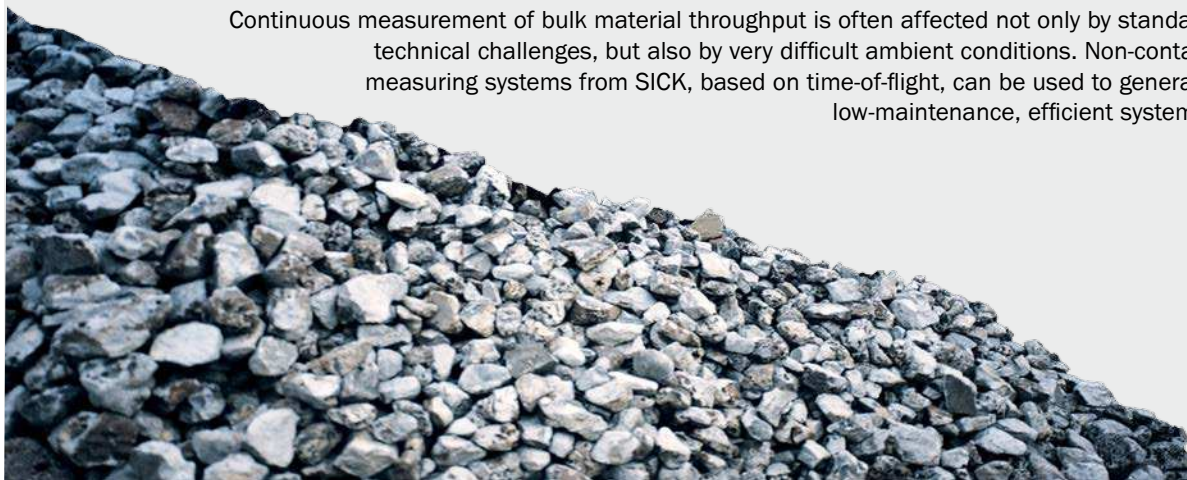



C

Non-contact flow measurement



Liquids



SICK's ultrasonic flow measurement sensors measure in both conductive and non-conductive liquids, and can be used in most applications. Whether you need to monitor flow, regulate dosage or monitor consumption, measurement devices from SICK offer an economical solution.



Flow measurement for liquid and bulk solid processes

Flow measurement in the cooling circuit



FFU

The FFU flow sensor monitors coolant flow rate. It can also be used to monitor measuring fluid via a switching output. As well as a compact design, the main feature of this application is reliable measurement which ensures optimum coolant flow, even with low conductivities.

Benefit:

- Can be used for conductive and non-conductive liquids, thus reducing storage costs and the number of variants required
- Straight measuring tube reduces pressure loss, saving energy costs
- No sensor seals increases process reliability and availability
- Flexible measuring system

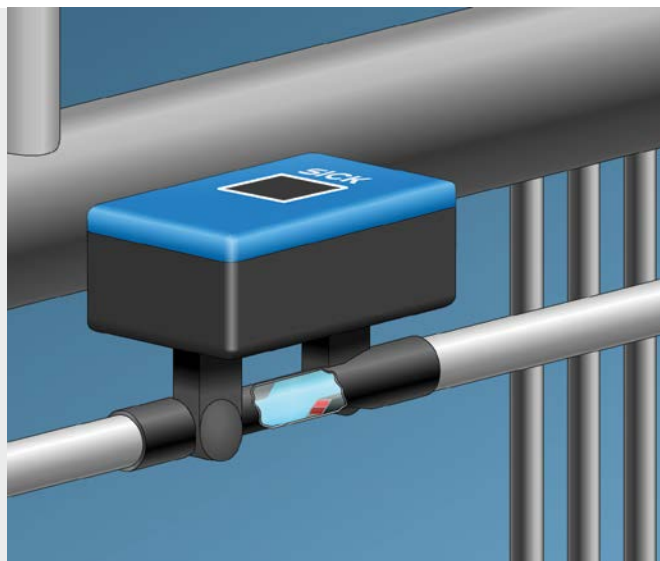

Two sensors positioned opposite one another send and receive ultrasonic signals in alternation. When the fluid is static, both sensors receive the sent ultrasonic signal in phase. If the fluid is moving, there is a phase shift proportional to the speed of the flow.

Throughput measurement on coal/ore conveyor belt



Bulkscan® LMS511

The Bulkscan® LMS511, a non-contact measuring device that detects the profile of bulk material on the conveyor belt. The belt speed and the bulk material profile are then used to calculate a volume flow. This can be used to generate a rule for optimum belt speed to ensure economic belt usage.

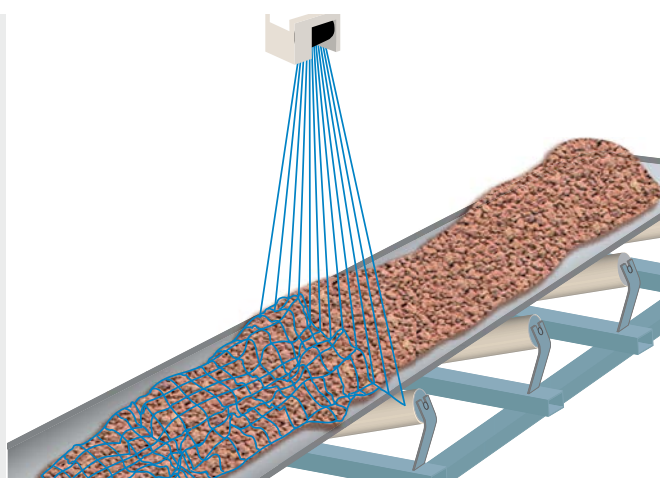

Benefit:

- Low-maintenance throughput measurement
- Flexible use
- Optimum belt usage
- Belt monitoring to reduce belt wear





A pulsed laser beam is emitted by a laser scanner. When the beam hits the bulk materials, it is reflected and registered in the scanner receiver. The time taken for the pulse to be sent and received again is directly proportional to the distance between scanner and bulk materials.

Product family overview

	 <p style="text-align: center;">FFU</p>	 <p style="text-align: center;">Bulkscan® LMS511</p>
	Non-contact flow measurement	Non-contact and maintenance-free sensor for measuring volume flow

Technical data overview		
Measuring principle	Ultrasonic sensor	Laser run-time technology
Medium	Fluids	Bulk solids
Output signal	Analog output: 4 ... 20 mA, 0 ... 20 mA for current flow and temperature, up to 2 pulse/status outputs: transistor output for flow rate meter, empty pipe detection, flow direction, flow monitoring, dosing output, 1 digital input for dosing, reset counter (depending on type)	Ethernet (TCP/IP) Switching inputs and outputs USB auxiliary interface RS-232/RS-422 4 mA ... 20 mA
Nominal width measuring tube	NW 10 NW 15 NW 20 NW 25	-
Max. conveyor speed	-	≤ 30 m/s
Maximum adjustable measuring range	0 l/min ... 240 l/min	-

At a glance		
	<div style="text-align: center;">  </div> <ul style="list-style-type: none"> • Flow sensor for conductive and non-conductive liquids • Compact design with no moving parts • Process temperature up to 80 °C, process pressure up to 16 bar • High chemical resistance due to seal-free sensor design • Large display with membrane keyboard • Integrated teaching tube detection 	<div style="text-align: center;">  </div> <ul style="list-style-type: none"> • Non-contact measurement of volume and mass flow of bulk material • Laser pulses with high angular resolution ensure outstanding image resolution • 5-echo pulse evaluation produces highly reliable measurements • Offers non-contact belt monitoring • Integrated center-of-gravity calculator • Robust structure for harsh ambient conditions • Can also measure at low temperatures thanks to integrated heater • Compact housing with enclosure rating IP 67
Detailed information	→ C-98	→ C-106

C

Non-contact flow measurement



C

Product description

The non-contact, ultrasonic flow sensor FFU detects the flow volumes of conductive and non-conductive liquids. Swimming against the current requires more strength than with the current – this is the simple fact on which ultrasonic flow measurement according to the phase difference process is based. Its compact design enables it to be used in a wide range of applications, including those with limited space.

This IP 67-rated sensor features a seal-free sensor design with high-quality polysulfone (Ultrason S), which not only makes it possible to use the device in harsh ambient conditions, but also ensures high process reliability. The large text display also helps provide simple, fast and hassle-free commissioning.

At a glance

- Flow sensor for conductive and non-conductive liquids
- Compact design with no moving parts
- Process temperature up to 80 °C, process pressure up to 16 bar
- High chemical resistance due to seal-free sensor design
- Large display with membrane keyboard
- Integrated teaching tube detection

Your benefits

- Reduced maintenance costs
- Adjustable measuring ranges reduces the number of variants
- Ability to be used with conductive and non-conductive liquids reduces variants and lowers storage costs
- Straight measuring tube reduces pressure loss, thus reducing energy costs
- Sensor without seals increases process reliability and availability
- Flexible measurement system for all industries



Additional information

Detailed technical data C-99
 Ordering information C-100
 Type code C-101
 Dimensional drawings C-101
 Recommended accessories C-104

→ www.mysick.com/en/FFU

For more information, just enter the link or scan the QR code and get direct access to technical data, CAD design models, operating instructions, software, application examples and much more.



Detailed technical data

Features

	NW 10	NW 15	NW 20	NW 25
Medium	Fluids			
Nominal width measuring tube	NW 10	NW 15	NW 20	NW 25
Process temperature	0 °C ... +80 °C			
Process pressure	Max. 16 bar		Max. 10 bar	

Performance

	NW 10	NW 15	NW 20	NW 25
Minimum flow	≤ 0.3 l/min	≤ 0.9 l/min	≤ 3.5 l/min	≤ 5 l/min
Maximum flow	≤ 21 l/min	≤ 36 l/min	≤ 60 l/min	≤ 240 l/min
Inlet zone	20 cm	30 cm	50 cm	60 cm
Outlet zone	0 cm	5 cm	10 cm	
Conductivity	No limitation			
Accuracy of sensor element ¹⁾	2 % (of final value) Optional 1 % of reading ± 3 mm/s (with calibration report)			
Repeatability	≤ 0.5 %			
Resolution	0.003 l/min	0.006 l/min	0.012 l/min	0.03 l/min

¹⁾ Reference condition: water, gas-free, fully-filled measuring tube, no cavitation, medium temperature 20 °C, ambient temperature 20 °C ... 25 °C, compliance with the inlet zone and outlet zone, warm-up time electronic: 30 min.

Mechanics

	NW 10	NW 15	NW 20	NW 25
Process connection	G ½ ½" NPT Clamp (DIN 11864-3)	G ¾ ¾" NPT Clamp (DIN 11864-3)	G 1 1" NPT Clamp (DIN 11864-3)	G 1 ¼ 1 ¼" NPT Clamp (DIN 11864-3)
Wetted parts	PSU			
Housing material	PSU			
Enclosure rating	IP 67			
Weight	340 g	350 g	420 g	460 g

Electronics

Supply voltage ¹⁾	18 V DC ... 30 V DC
Residual ripple ²⁾	≤ 5 V _{pp}
Power consumption ³⁾	≤ 180 mA
Initialization time	≤ 5 s
Protection class	III
Electrical connection	M12 x 1, 5-pin M12 x 1, 8-pin (depending on type)

¹⁾ All connections are polarity protected. All outputs are overload and short-circuit protected.

²⁾ May not exceed or fall short of V_s tolerances.

³⁾ Without load.

⁴⁾ There are 100 mA for each output PNP and NPN available.

⁵⁾ Analog output and display.

Output signal ¹⁾	Analog output: 4 mA ... 20 mA, 0 mA ... 20 mA current flow and temperature, 1 pulse/status output: transistor output for flow rate meter, empty pipe detection, flow monitoring, dosing output, flow direction Analog output: 4 mA ... 20 mA, 0 mA ... 20 mA current flow and temperature, 2 pulse/status output: transistor output for flow rate meter, empty pipe detection, flow monitoring, 1 digital input for dosing and counter reset
Impulse/frequency output	0 kHz ... 10 kHz
Pulse width	≤ 1 s
Signal voltage HIGH	V _s - 2 V
Signal voltage LOW	≤ 2 V
Output current ⁴⁾	< 100 mA
Inductive load	1 H
Capacitive load	100 nF
Response time ⁵⁾	Filter off: 100 ms, filter low: 300 ms, filter medium: 1 s, filter strong: 4.2 s
Output load	< 500 Ohm
Lower signal level	3.8 mA ... 4 mA
Upper signal level	20 mA ... 20.5 mA

¹⁾ All connections are polarity protected. All outputs are overload and short-circuit protected.

²⁾ May not exceed or fall short of V_s tolerances.

³⁾ Without load.

⁴⁾ There are 100 mA for each output PNP and NPN available.

⁵⁾ Analog output and display.

C

Ambient data

Ambient operating temperature	0 °C ... +60 °C
Ambient storage temperature	-20 °C ... +70 °C

Ordering information

The part numbers below show a selection of our common configurations and represent only a portion of the product portfolio. The type code on page C-101 indicates all possible configurations that can be ordered.

Process pressure	Nominal width measuring tube	Maximum flow	Process connection	Model name	Part no.
Max. 16 bar	NW 10	0 l/min ... 21 l/min	G ½	FFUS10-1G1IO	6041737
			½" NPT	FFUS10-1G1SR	6043743
			Clamp (DIN 11864-3)	FFUS10-1G1IO	6047868
	NW 15	0 l/min ... 36 l/min	G ¾	FFUS10-1C1IO	6049101
			¾" NPT	FFUS15-1G1IO	6041249
			Clamp (DIN 11864-3)	FFUS15-1G1SR	6043744
Max. 10 bar	NW 20	0 l/min ... 60 l/min	¾" NPT	FFUS15-1N1IO	6047869
			Clamp (DIN 11864-3)	FFUS15-1C1IO	6045162
			G 1	FFUS20-1G1IO	6041738
	NW 25	0 l/min ... 240 l/min	1" NPT	FFUS20-1G1SR	6043745
			Clamp (DIN 11864-3)	FFUS20-1N1IO	6047870
			G 1¼	FFUS20-1C1IO	6049061
NW 25	0 l/min ... 240 l/min	G 1¼	FFUS25-1G1IO	6041739	
		1 ¼" NPT	FFUS25-1G1SR	6043746	
		Clamp (DIN 11864-3)	FFUS25-1N1IO	6044996	
				FFUS25-1N1SR	6049566
				FFUS25-1C1IO	6044523

Type code

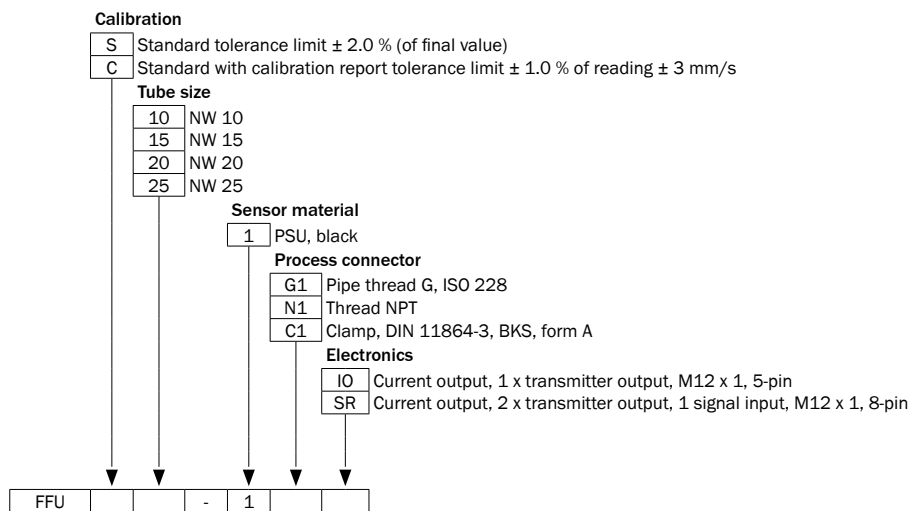

Not all variations of the type code can be combined!

Dimensional drawings

dimensions in mm (inch)

NW 10, G 1/2

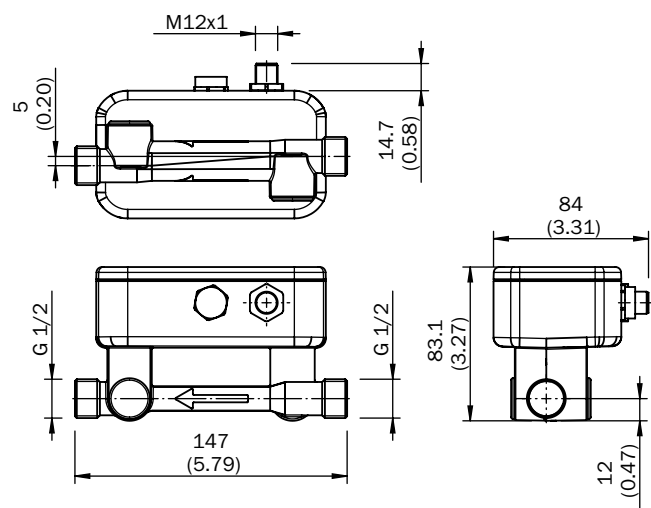

NW 10, 1/2" NPT

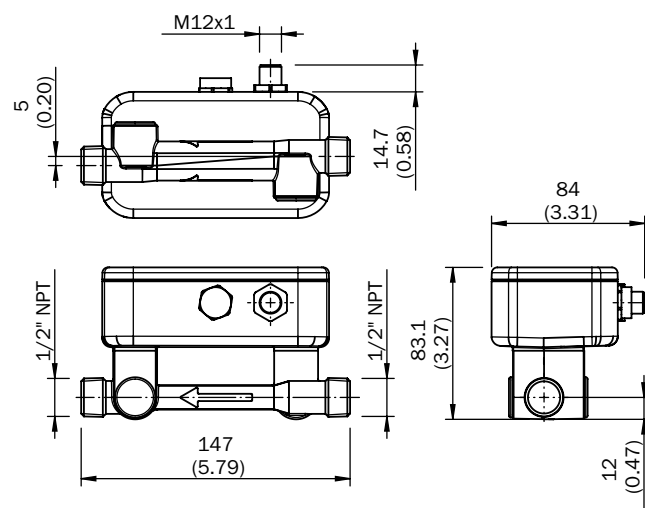

C

NW 10, Clamp (DIN 11864-3)

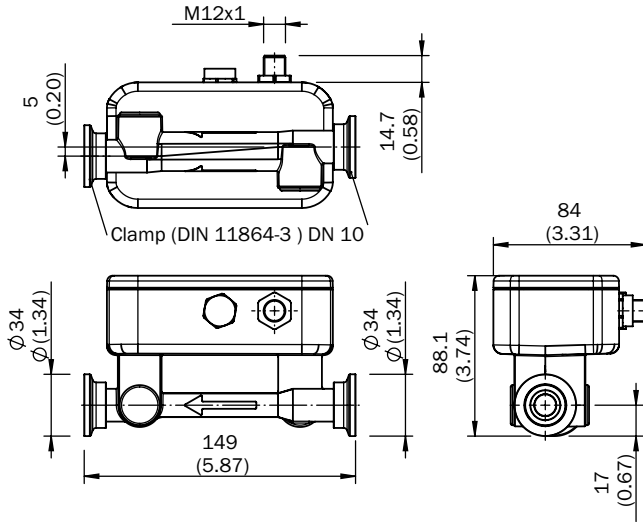

NW 15, G 3/4

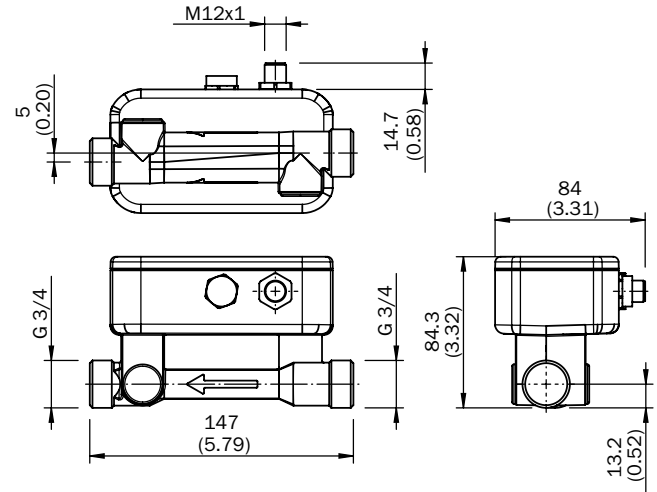

NW 15, 3/4" NPT

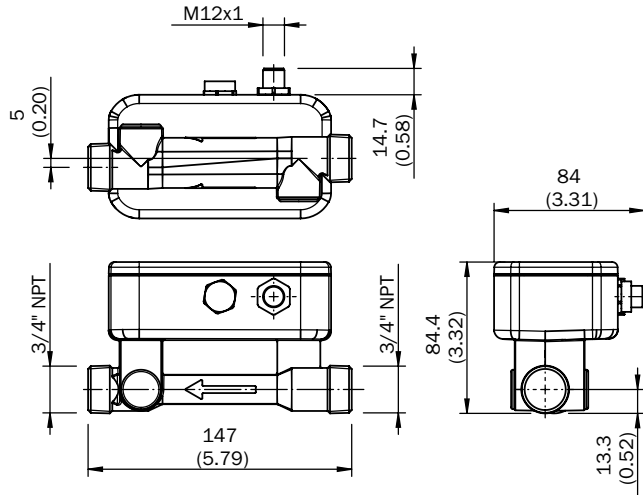

NW 15, Clamp (DIN 11864-3)

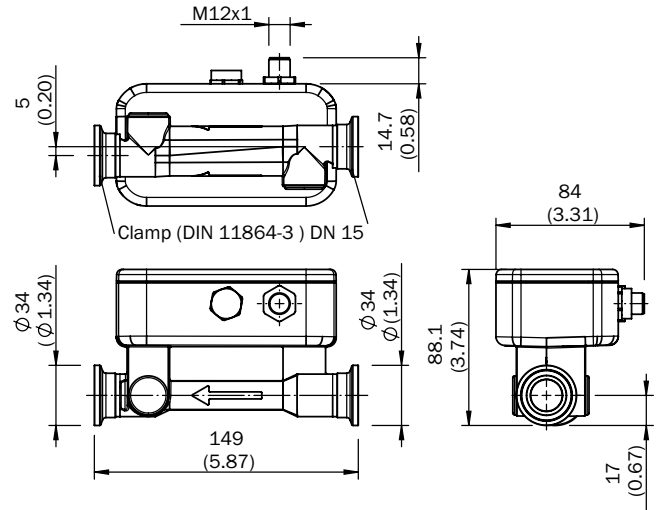

NW 20, G 1

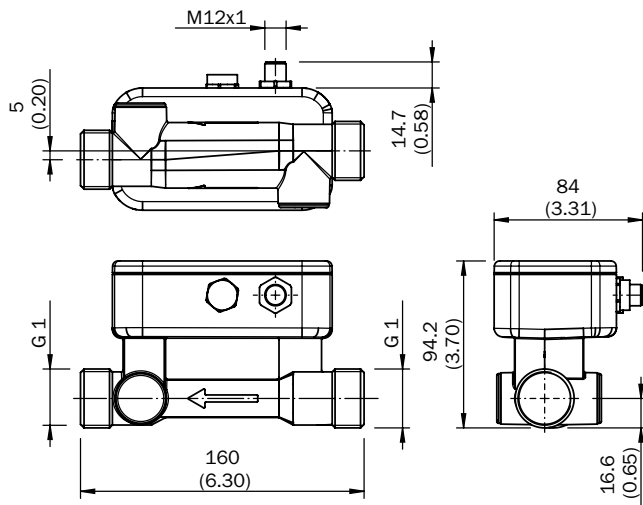

NW 20, 1" NPT

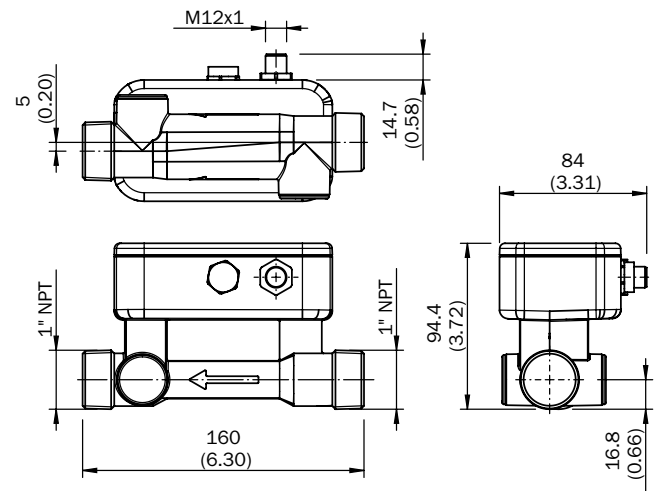

C

NW 20, Clamp (DIN 11864-3)

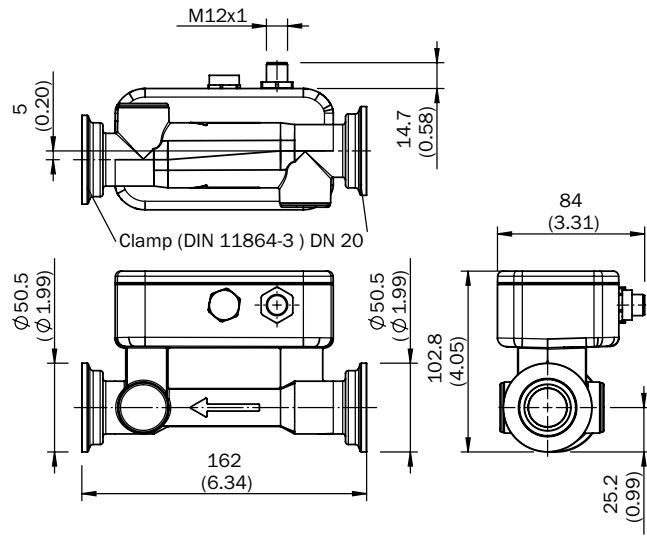

NW 25, G 1 1/4

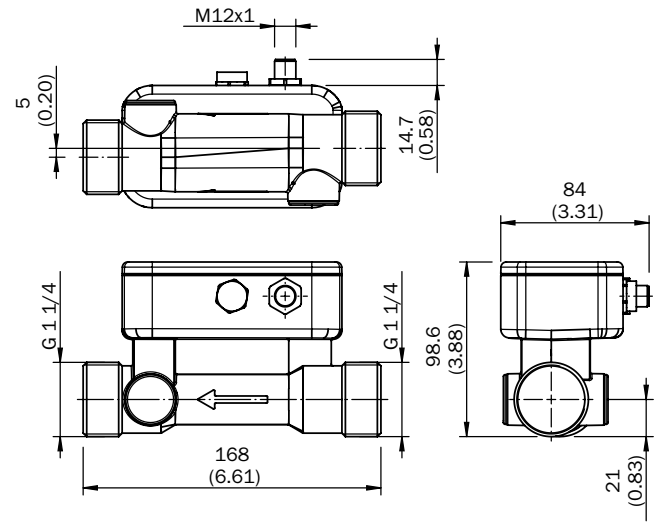

NW 25, 1 1/4" NPT

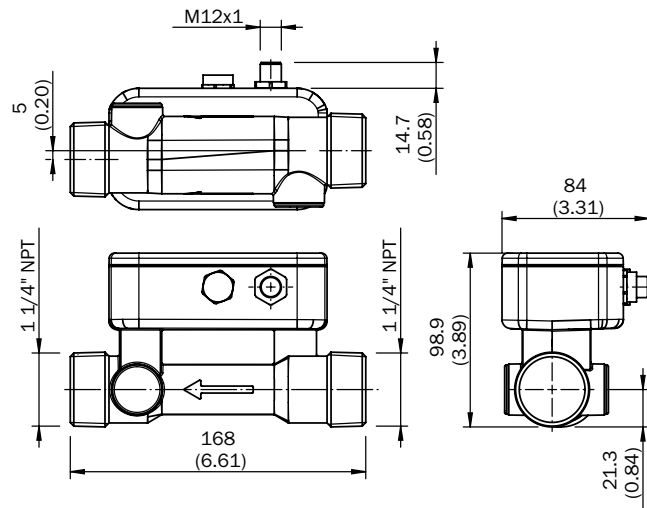

NW 25, Clamp (DIN 11864-3)

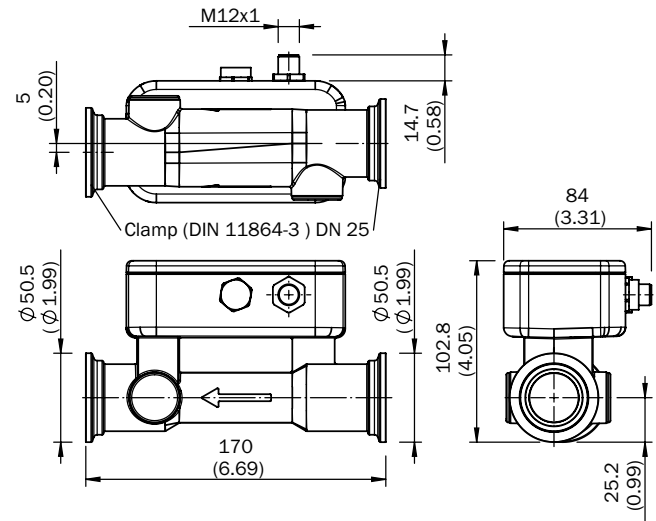

Recommended accessories

Plug connectors and cables

	Brief description	Type	Part no.
 Illustration may differ	Cable, M12, 5-pin, straight connector female with molded cable, 2 m, PVC	DOL-1205-G02M	6008899
 Illustration may differ	Cable, M12, 5-pin, straight connector female with molded cable, 2 m, PUR halogen free	DOL-1205-G02MC	6025906
 Illustration may differ	Cable, M12, 5-pin, straight connector female with molded cable, 5 m, PVC	DOL-1205-G05M	6009868
 Illustration may differ	Cable, M12, 5-pin, straight connector female with molded cable, 5 m, PUR halogen free	DOL-1205-G05MC	6025907
 Illustration may differ	Cable, M12, 5-pin, straight connector female with molded cable, 10 m, PVC	DOL-1205-G10M	6010544
 Illustration may differ	Cable, M12, 5-pin, straight connector female with molded cable, 10 m, PUR halogen free	DOL-1205-G10MC	6025908
 Illustration may differ	Cable, M12, 5-pin, angled connector female with molded cable, 2 m, PVC	DOL-1205-W02M	6008900
 Illustration may differ	Cable, M12, 5-pin, angled connector female with molded cable, 2 m, PUR halogen free	DOL-1205-W02MC	6025909
 Illustration may differ	Cable, M12, 5-pin, angled connector female with molded cable, 5 m, PVC	DOL-1205-W05M	6009869
 Illustration may differ	Cable, M12, 5-pin, angled connector female with molded cable, 5 m, PUR halogen free	DOL-1205-W05MC	6025910
 Illustration may differ	Cable, M12, 5-pin, angled connector female with molded cable, 10 m, PUR halogen free	DOL-1205-W10MC	6025911
 Illustration may differ	Cable, M12, 8-pin, straight connector female with molded cable, 2 m, PVC, screened, spec. color code	DOL-1208-G02MF	6020663
	Cable, M12, 8-pin, straight connector female with molded cable, 5 m, PVC, screened, spec. color code	DOL-1208-G05MF	6020664
	Cable, M12, 8-pin, straight connector female with molded cable, 10 m, PVC, screened, spec. color code	DOL-1208-G10MF	6048434

C

C

Non-contact and maintenance-free sensor for measuring volume flow



C

Product description

The Bulkscan® LMS511 uses time-of-flight technology for non-contact measurement of volume flow on conveyor belts. Using multi-echo technology, the Bulkscan® LMS511 can combine time-of-flight data with belt speed to generate a reliable volume flow signal, regardless of the bulk material's properties or weather conditions. Aside from calculating total quantities and mass flow, the Bulkscan® LMS511 can monitor the operation of the conveyor belt without

coming into physical contact with it and promptly gives warning of any belt slippage. The integrated center-of-gravity calculator can be used to detect uneven loading of the bulk material and avoid excessive belt wear. Its tough industrial housing is well-suited to rugged operating conditions. An integrated heater also ensures safe operation at low ambient temperatures. Discrete signals as well as Ethernet TCP/IP can be used to connect the measuring system to a host communication system.

At a glance

- Non-contact measurement of volume and mass flow of bulk material
- Laser pulses with high angular resolution ensure outstanding image resolution
- 5-echo pulse evaluation produces highly reliable measurements
- Offers non-contact belt monitoring
- Integrated center-of-gravity calculator
- Robust structure for harsh ambient conditions
- Can also measure at low temperatures thanks to integrated heater
- Compact housing with enclosure rating IP 67

Your benefits

- Maximizes conveyor throughput
- Reduces maintenance costs by preventing belt slippage
- Increases the conveyor belt's service life
- Reduces loading time
- Increases efficiency by optimizing belt capacity
- Simple installation
- Low maintenance costs
- Offers savings through minimized energy consumption



Additional information

Detailed technical dataC-107

Ordering informationC-108

Dimensional drawingsC-108

Instruction for installationC-109

Recommended accessoriesC-110

→ www.mysick.com/en/Bulkscan_LMS511

For more information, just enter the link or scan the QR code and get direct access to technical data, CAD design models, operating instructions, software, application examples and much more.



Detailed technical data

Features

Light source	Infrared (905 nm)
Laser class	1, eye-safe (IEC 60825-1 (2007-6))
Field of view	190°
Scanning frequency	35 Hz 50 Hz 75 Hz
Heating	Yes
Operating range	0.5 m ... 20 m
Amount of evaluated echoes	5

Performance

Response time	13 ms, 20 ms, 28 ms
Average filter	0 s ... 3,600 s
Accuracy	± 3 %, under perfect conditions ± 5 %, depending on the profile
Max. conveyor speed	≤ 30 m/s

Interfaces

Auxiliary interface	Protocol	USB 2.0
	Data transmission rate	≤ 500 kBaud
Serial host interfaces	Protocol	RS-232/RS-422
	Data transmission rate	≤ 500 kBaud
Ethernet	Protocol	TCP/IP
	Data transmission rate	100 Mbit/s
Switching inputs	2 (+ Encoder)	
Switching outputs	6	
Optical indicators	5 LEDs (additional 7-segment display)	

Mechanics/electronics

Electrical connection	M12, 5-pin plug-in connector
Supply voltage scanner/heater	19.2 V ... 28.8 V
Prohibited residual ripple	± 5 %
Switch-on peak current	2 A
Operating current scanner	1.3 A
Power consumption	Scanner: 22 W; heating: 55 W
Housing color	Gray (RAL 7032)
Enclosure rating	IP 67 (EN 60529, Section 14.2.7)
Protection class	III
Weight	3.7 kg
Dimensions	160 mm x 155 mm x 185 mm
Distance of the sensor to the bulk solid	≥ 0.5 m
Switch-on time	≤ 60 s

Ambient data

Electromagnetic compatibility (EMC)	EN 61000-6-2: 2005 / EN 61000-6-3 (2007-03)
Ambient operating temperature	-30 °C ... +50 °C
Storage temperature	-30 °C ... +70 °C
Ambient light safety	70,000 lx

Ordering information

Model name	Part no.
Bulkscan® LMS511-20190	1059529

Dimensional drawings

dimensions in mm (inch)

Bulkscan® LMS511

C

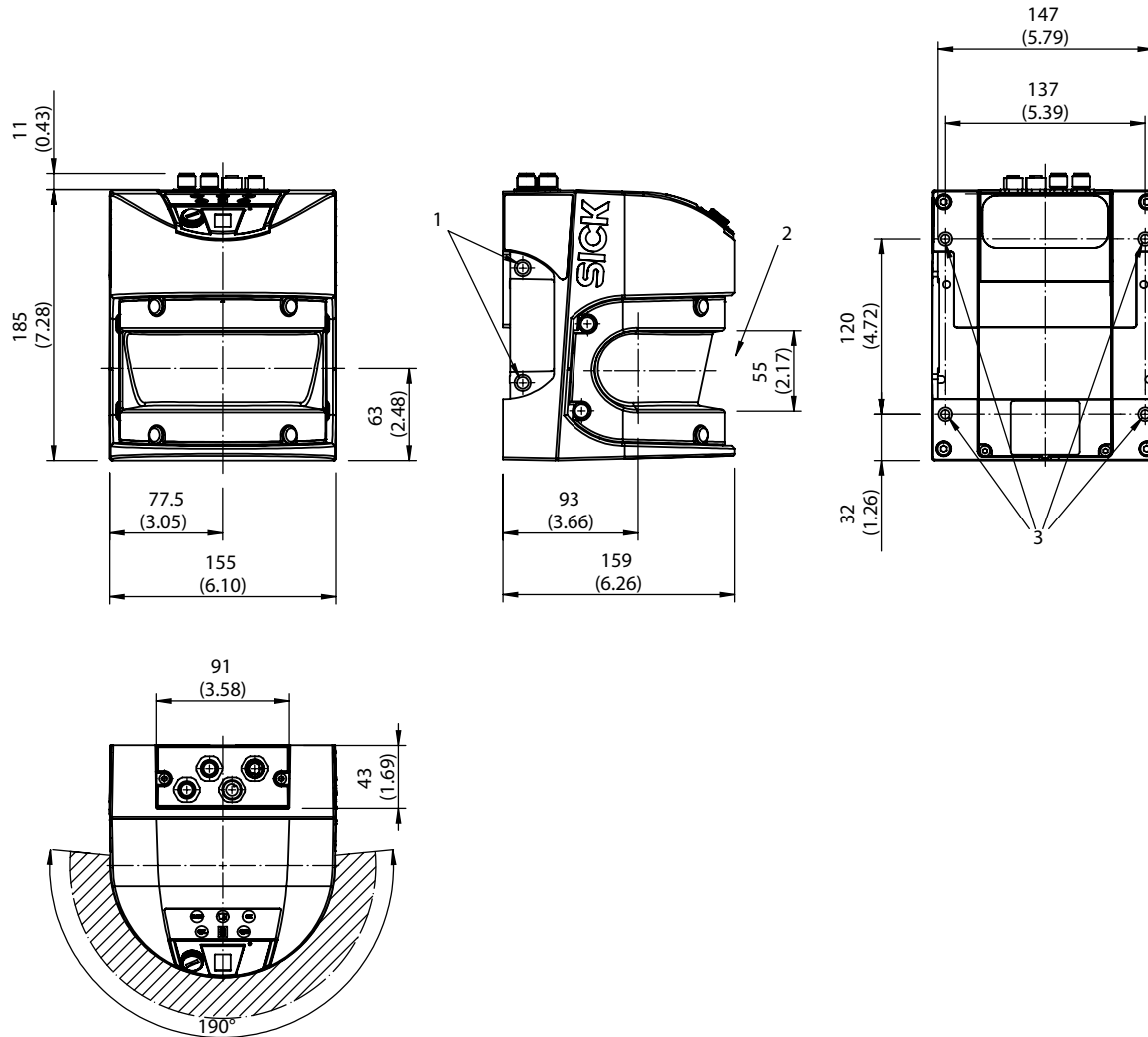

- ① 4 screw holes M8 x 9
- ② Do not obstruct front window
- ③ 4 screw holes M6 x 8

Instruction for installation

Pole mounting bracket

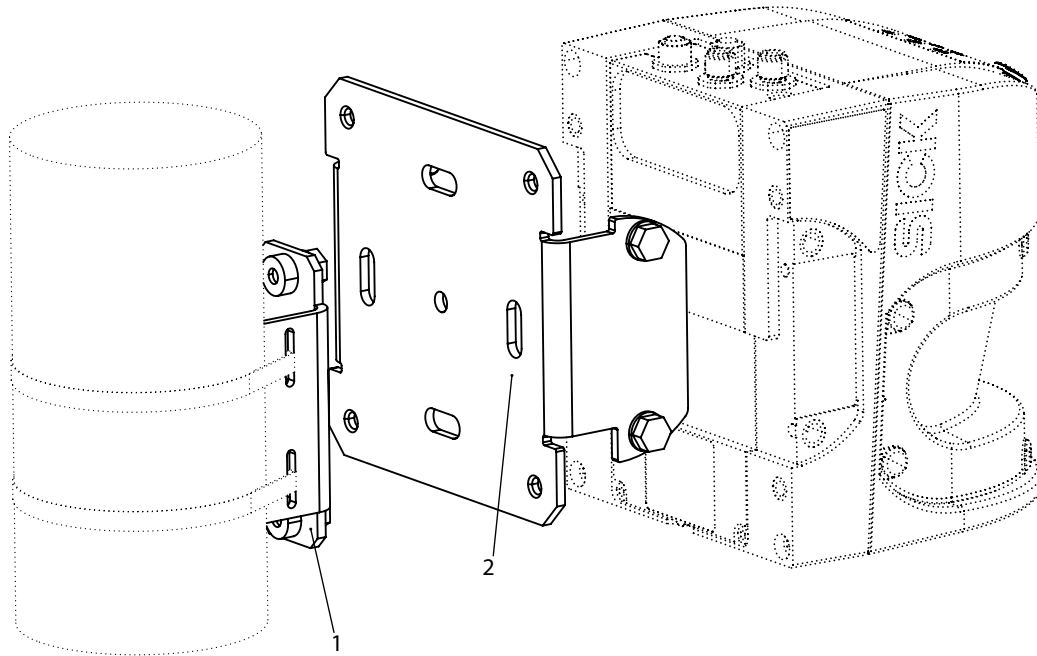

- ① Pole mounting bracket
- ② Adapter bracket

Mounting bracket

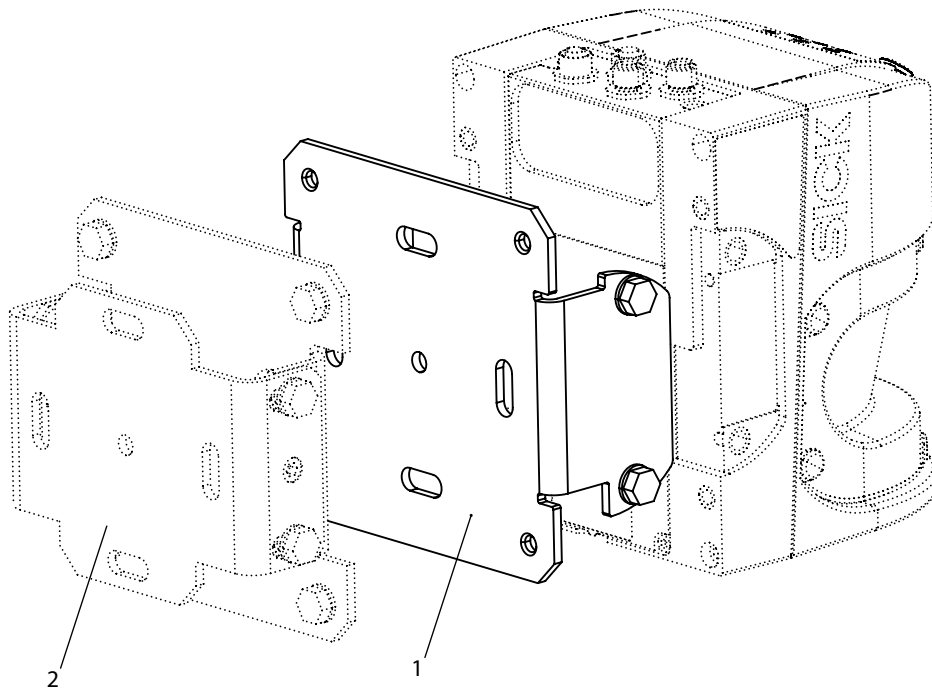

- ① Mounting bracket
- ② Mounting set for LMS2xx Part no. 2018303

C

Mounting set

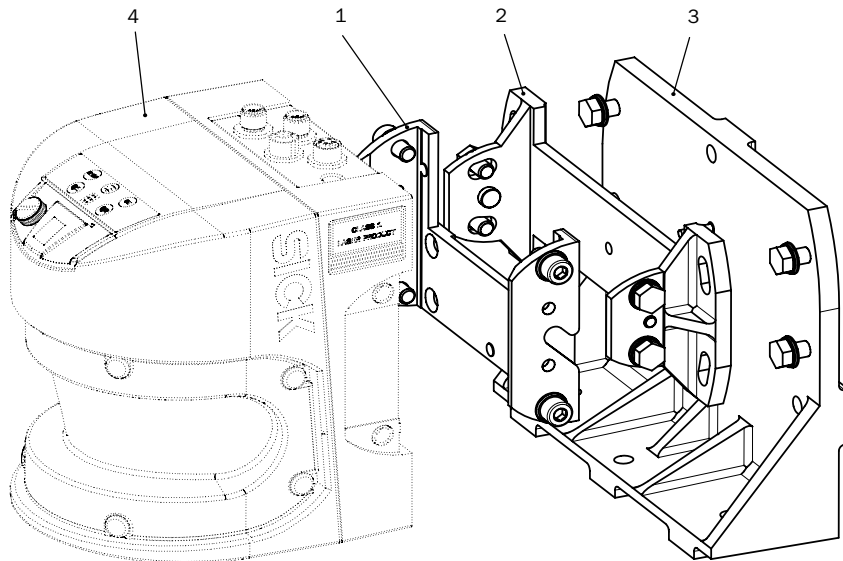





- ① Mounting set 1
- ② Mounting set 2
- ③ Mounting set 3
- ④ Product

C

Recommended accessories

Mounting brackets/plates

	Brief description	Model name	Part no.
	Mounting bracket for direct mounting, from the rear, on wall or machine, not adjustable	Mounting kit 1	2015623
	Mounting bracket for rear mounting on wall or machine, adjustable longitudinal and lateral axes, only in conjunction with mounting kit 1 (2015623)	Mounting kit 2	2015624
	Mounting bracket for rear mounting on wall, floor, or machine, adjustable longitudinal and lateral axes, only in conjunction with mounting kit 1 (2015623) and 2 (2015624)	Mounting kit 3	2015625
	Mounting bracket for LMS5xx (for retrofitting, if 2018303 is already in use)	Mounting bracket	2059271
	Spring arm/mounting arm	DFV60 spring arm	2056155

Terminal and alignment brackets

	Brief description	Model name	Part no.
	Pole bracket (additionally required: adapter bracket 2059271 for LMS5xx / mounting set 2018303 for LD-LRS)	Alignment bracket	2018304

Power supply units

	Brief description	Model name	Part no.
	Power supply DC 24 V , 4 A, 120/230 V AC	Power supply	6010362
	Power supply DC 24 V, 10 A	Power supply	6020875

Optics cloths

	Brief description	Model name	Part no.
	Lens cloth	Lens cloth	4003353



Encoder

	Brief description	Model name	Part no.
	Incremental measuring wheel encoder, electrical interface: 10 ... 30 V HTL / push-pull, universal mounting bracket, measuring wheel circumference = 300 mm, surface 0 - ring, connection: M12, 8-pin, number of lines 1024, operating temperature -20 °C ... 100 °C	DFV60E-22EC01024	1060308
Illustration may differ	Incremental measuring wheel encoder, electrical interface: 10 ... 30 V HTL / push-pull, universal mounting bracket, measuring wheel circumference = 300 mm, surface 0 - ring, connection: cable, 1.5 m, number of lines 1024, operating temperature -20 °C ... 100 °C	DFV60E-22EK01024	1060309



Test and monitoring tools

	Brief description	Model name	Part no.
	Scan finder, receiver to localize infrared scans	LS70b	6020756

Other mounting accessories

	Brief description	Model name	Part no.
	Strap for mast bracket (sold by meter)	Clamping strap	5306222
	Strap lock	Clamping strap lock	5306221

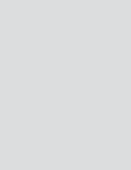
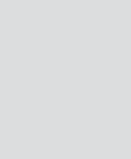
Plug connectors and cables

	Brief description	Model name	Part no.
	Power supply cable, 4 x 0.75 mm ² , shielded, M12 socket, 5-pin (A-type encoded) / open end, 10 m	Connecting cable (female connector open)	6042565
	Power supply cable, 4 x 0.50 mm ² , shielded, M12 socket, 5-pin (A-type encoded) / open end, 5 m	Connecting cable (female connector open)	6036159
	Power supply cable, 4 x 0.75 mm ² , shielded, M12 socket, 5-pin (A-type encoded) / open end, 20 m	Connecting cable (female connector open)	6042564
	Data (RS-232/-422) and I/O connection cable, 12-pole, shielded, M12 socket, 12-pin (A-type encoded) / open end, 5 m	Connecting cable (female connector open)	6042735
	Data (RS-232/422) and I/O connection cable, 12-pole, shielded, M12 socket, 12-pin (A-type encoded) / open end, 10 m	Connecting cable (female connector open)	6042736
	Data (RS-232/422) and I/O connection cable, 12-pole, shielded, M12 socket, 12-pin (A-type encoded) / open end, 20 m	Connecting cable (female connector open)	6042737
	I/O connection cable, 12-pole, shielded, M12 plug, 12-pin (A-type encoded) / open end, 20 m	Connecting cable (male connector open)	6042734
	I/O connection cable, 12-pole, shielded, M12 plug, 12-pin (A-type encoded) / open end, 10 m	Connecting cable (male connector open)	6042733
	I/O connection cable, 12-pole, shielded, M12 plug, 12-pin (A-type encoded) / open end, 5 m	Connecting cable (male connector open)	6042732
	Ethernet cable, 4-pole, shielded, M12 plug, 4-pin (D-type encoded) / RJ-45 plug, 8-pin, 10 m	Connecting cable (male connector - male connector)	6030928
	Ethernet cable, 4-pole, shielded, M12 plug, 4-pin (D-type encoded) / RJ-45 plug, 8-pin, 20 m		6036158
	Ethernet cable, 4-pole, shielded, M12 plug, 4-pin (D-type encoded) / RJ-45 plug, 8-pin, 5 m		6034415
	USB cable, 4-pole, shielded, plug type mini B / plug type A, 3 m	(male connector - male connector)	6042517



Universal pressure measurement for liquids and gases

SICK's portfolio of electronic pressure transmitters and switches can be optimally adapted to individual customer's requests thanks to its intelligent and versatile configuration possibilities. Typical of all solutions from SICK is the use of high-quality materials, robustness and precise measurement technology, in addition to being easy to operate and install.

Your benefits

- Reliable and highly accurate measurement technology
- Wide application range
- Optimal solution for individual requirements due to very versatile configurability



Pressure sensors

D

General informationD-114
Product family overviewD-117

 PBSD-118
Universal pressure switch	
 PBTD-126
All-around pressure transmitter	
 PFTD-136
The flexible solution	
 PHTD-144
A clean solution	
 PETD-152
If one is not enough	



Pressure measurement in liquids and gases

Measurement of pressure plays a central role in many areas of plant and mechanical engineering, the manufacturing industry, machine tooling, process engineering and the manufacture and processing of food and beverages.

Precise measurement technology

SICK's portfolio of electronic pressure transmitters and switches can be adapted optimally to the customer's individual requirements thanks to its intelligent and versatile configuration possibilities.

Thus, a wide selection of graded measurement ranges, common process connections and industry-typical output signals are available. To develop more application areas, the pressure sensors are also available in various precision classes, with extended temperature ranges or with flush-mounted membranes.

Pressure transmitter

Pressure measurement in industrial applications typically occurs with the help of pressure transmitters. The equipment delivers a continuous current or voltage signal proportional to the pressure applied.

With the PBT pressure transmitter series, applications are handled reliably and cost-effectively. Challenging measurement tasks are handled using the pressure transmitters of the PFT series. The PFT series offers hygienic pressure transmitters for use, for example, in the food and beverage industry.

Pressure switch

Pressure switches are used to monitor pressure. Electronic pressure switches are characterized by their digital switching outputs, which are activated or deactivated when defined, programmable threshold levels have been reached.

The PBS pressure switch offers fast, safe and cost-effective operation. With its large operating buttons, the bright display panel and the intuitive menu navigation according to VDMA-Recommendation 24574-1, its ease of use is impressive.

In addition, the PBS pressure switch offers clear advantages during integration and installation. By means of a dual turnable housing design, cable routing and orientation of the display can be adapted optimally to any given installation situation. In addition to its pressure-monitoring function as pressure switch with digital transistor-switching outputs, the PBS can also generate an analog output signal.

D

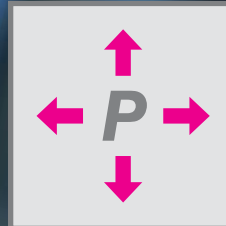

Control of workpiece clamping pressure with PBS with IO-Link

In CNC machines, the workpieces are often clamped hydraulically. Electronic pressure switches such as the PBS make sure that the correct clamping pressure is applied. IO-Link enables quick and error-free adjustment of the switching thresholds upon product changeover, thus increasing machine availability.

Benefits:

- Pressure switch, pressure transmitter and display in one device
- Quick product changeover through setpoint adjustment via IO-Link
- Ergonomic: Legible display, large buttons and turnable housing
- Rugged and reliable
- Various installation options

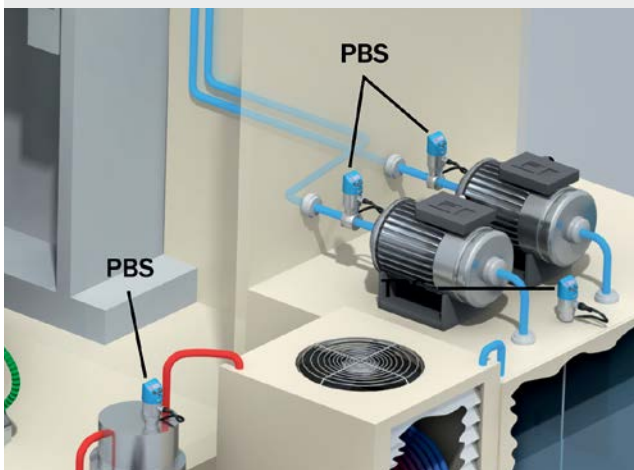

Monitoring of tool clamping pressure with PBS



Hydraulic systems are employed in many areas in the machine tool industry. In CNC machines, tools are often clamped hydraulically. Monitoring the correct clamping pressure can be done using electronic pressure switches such as the PBS.

Benefits:

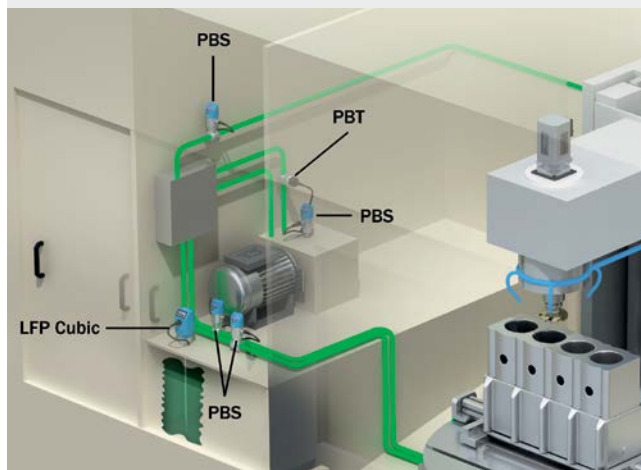
- Pressure switch, pressure transmitter and display in one device
- Simple operation
- Rugged and reliable
- Quick installation and commissioning
- Various configurations



Product family overview

	
PBS	PBT
Universal pressure switch	All-around pressure transmitter

Technical data overview			
Device type	Pressure switch	Pressure transmitter	
Measuring ranges			
Gauge pressure	0 bar ... 1 bar up to 0 bar ... 600 bar	0 bar ... 1 bar up to 0 bar ... 600 bar	
Absolute pressure	0 bar ... 1 bar up to 0 bar ... 25 bar	0 bar ... 1 bar up to 0 bar ... 25 bar	
Compound pressure	-1 bar ... 0 bar up to -1 bar ... +24 bar	-1 bar ... 0 bar up to -1 bar ... +24 bar	
Pressure unit	bar, MPa, psi and kg/cm ²	bar, MPa, psi and kg/cm ²	
Accuracy	≤ ± 1 %	≤ ± 1 %	
Setting accuracy of switching outputs	≤ ± 0.5 % of span	-	
Output signal	Switching outputs PNP or NPN plus optional IO-Link and analog output signal	Analog	
Electrical connection	Round connector M12 x 1	Round connector M12 x 1, L-connector, flying leads	

At a glance			
	<ul style="list-style-type: none"> • Electronic pressure switch with display for monitoring pressure in liquids and gases • Precise sensor technology with stainless steel membrane • Integrated process connections manufactured from high-quality stainless steel • Pressure values indicated on display. Output states are indicated separately via wide-angle LEDs. • Unit of pressure value in display can be switched • Min/max memory • Password protection 	<ul style="list-style-type: none"> • Pressure measurement ranges from 0 bar ... 1 bar up to 0 bar ... 600 bar • Gauge, absolute and compound measurement ranges • A large variety of available process connections • No moving parts: No mechanical wear, fatigue-proof, maintenance-free • Circularly welded, hermetically sealed stainless steel membrane • Output signal 4 mA ... 20 mA, 0 V ... 5 V or 0 V ... 10 V • Electrical connection M12 x 1, L-connector acc. to DIN 175301-803 A or flying leads 	

Detailed information	→ D-118	→ D-126	
----------------------	-------------------------	-------------------------	--

D



PFT

The flexible solution



PHT

A clean solution



PET

If one is not enough

Pressure transmitter	Pressure transmitter	Pressure transmitter
0 bar ... 0.1 bar up to 0 bar ... 600 bar	0 bar ... 0.25 bar up to 0 bar ... 25 bar	0 bar ... 6 bar up to 0 bar ... 600 bar
0 bar ... 0.25 bar up to 0 bar ... 25 bar	0 bar ... 0.25 bar up to 0 bar ... 16 bar	-
-1 bar ... 0 bar up to -1 bar ... +30 bar	-1 bar ... 0 bar up to -1 bar ... +15 bar	-1 bar ... +5 bar up to -1 bar ... +59 bar
bar, MPa, psi and kg/cm ²	bar, MPa, psi and kg/cm ²	bar, psi, kg/cm ² , kPa and Mpa
≤ ± 0.5 %	≤ ± 0.5 %	≤ ± 1.2 %
≤ 0.25 %	≤ ± 0.25 %	-
-	-	-
Analog	Analog	Analog
Round connector M12 x 1, L-connector, flying leads	Round connector M12 x 1, L-connector, flying leads, field housing	Round connector M12 x 1, 4-pin, for L-connector according to DIN EN 175301-803 A (without plug)



Hygienic

- Measurement ranges from 0 mbar ... 100 mbar up to 0 bar ... 600 bar
- Gauge, absolute and compound measurement ranges
- Variant with flush-mounted membrane available
- Process temperature up to 150 °C (optional)
- Large variety of commonly used process connections
- High shock and vibration resistance
- Accuracy 0.5 % or 0.25 %
- Output signal 4 mA ... 20 mA, 0 V ... 5 V or 0 V ... 10 V
- Zero and span adjustable
- Electrical connection M12 x 1, L-connector according to DIN 175301-803 A or flying leads

→ D-136

- Robust and precise pressure measurement technology
- Flush-mounted, hermetically sealed stainless steel membrane with roughness Ra < 0.4 µm
- Wetted parts stainless steel 1.4435, housing stainless steel 1.4571
- CIP/SIP resistant
- Large range of hygienic process connectors
- Stainless steel housing with enclosure rating of up to IP 68
- Field housing available (IP 67)

→ D-144

- Measuring ranges from 0 bar ... 6 bar up to 0 bar ... 600 bar
- Various output signals and electrical connections available
- Common process connections available
- High overpressure safety. Pressure peak protection available upon request for selected process connections.
- Circularly welded, hermetically sealed stainless steel membrane
- Stainless steel housing with enclosure rating up to IP 67 (with round connector M12 x 1)

→ D-152

D

Universal pressure switch



Product description

The PBS is an electronic pressure switch, pressure transmitter and display in one. It is available with up to two switching outputs, analog output and IO-Link in a single device.

Its intuitive configuration via three large pushbuttons and display facilitates operation. The housing can be rotated in two ways. This means that the display and electrical connection can be aligned to match the specific installation situation.

The PBS can be utilized in a wide range of applications due to its gauge

pressure measuring ranges between 0 bar ... 1 bar and 0 bar ... 600 bar. In addition, absolute pressure and compound measuring ranges are available.

The PBS features a fully welded stainless steel membrane, making it suitable for use with a host of corrosive media. Numerous standard process connections make adapters redundant in most cases. In addition, a flush-mounted membrane is available for pressure measurement in heterogeneous liquids.

At a glance

- Electronic pressure switch with display for monitoring pressure in liquids and gases
- Precise sensor technology with stainless steel membrane
- Integrated process connections manufactured from high-quality stainless steel
- Pressure values indicated on display. Output states are indicated separately via wide-angle LEDs.
- Unit of pressure value in display can be switched
- Min/max memory
- Password protection

Your benefits

- Quick and easy setup and operation due to three large pushbuttons and clear display
- Perfect display readability and optimal cable routing due to rotatable housing
- No compromises: Individual solutions through a variety of configurations
- Universal application due to fully welded, highly durable stainless steel membrane
- Saves space and costs: No adapters required due to broad range of standard process connections
- Highly reliable due to application of proven technologies and high-quality materials, water resistance according to IP 65 and IP 67 as well as excellent overpressure safety
- Ultimate system availability: IO-Link enables fast, reliable parameter setting when changing over products

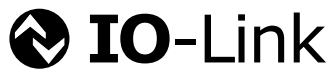

Additional information

Detailed technical dataD-119
 Ordering informationD-120
 Type codeD-123
 Dimensional drawingsD-124
 Recommended accessoriesD-125

→ www.mysick.com/en/PBS

For more information, just enter the link or scan the QR code and get direct access to technical data, CAD design models, operating instructions, software, application examples and much more.



D

Detailed technical data

Features

Pressure units	bar, MPa, psi and kg/cm ²						
Measuring ranges	<table border="0"> <tr> <td style="padding-right: 20px;">Gauge pressure</td> <td>0 bar ... 1 bar up to 0 bar ... 600 bar</td> </tr> <tr> <td>Absolute pressure</td> <td>0 bar ... 1 bar up to 0 bar ... 25 bar</td> </tr> <tr> <td>Compound pressure</td> <td>-1 bar ... 0 bar up to -1 bar ... +24 bar</td> </tr> </table>	Gauge pressure	0 bar ... 1 bar up to 0 bar ... 600 bar	Absolute pressure	0 bar ... 1 bar up to 0 bar ... 25 bar	Compound pressure	-1 bar ... 0 bar up to -1 bar ... +24 bar
Gauge pressure	0 bar ... 1 bar up to 0 bar ... 600 bar						
Absolute pressure	0 bar ... 1 bar up to 0 bar ... 25 bar						
Compound pressure	-1 bar ... 0 bar up to -1 bar ... +24 bar						
Process temperature	-20 °C ... +85 °C						
Signal output and maximum ohmic load R_A	4 mA ... 20 mA (R _A ≤ 0.5 kOhm) 0 V ... 10 V (R _A > 10 kOhm) Adjustment zero point offset max + 3 % of span						
Switching output	Transistor switching output PNP or NPN Number: 1 or 2 (with IO-Link: C/Q1: PNP) Function: Normally open/normally closed, windows- and hysteresis function freely adjustable Contact rating: Supply voltage L ⁺ - 1 V [V DC] Max. switching current: 250 mA, with IO-Link: C/Q ₁ : 100 mA, Q ₂ : 250 mA Switching delay: 0 s ... 50 s (adjustable) Response time: ≤ 10 ms Individually adjustable via external control buttons, setting accuracy: ≤ 0.5 % of span						
Rotatable housing	Display against housing with electrical connection: 330° Housing against process connection: 320°						
Display	14-segment LED, blue, 4 digits, height 9 mm, electronically turnable by 180° Accuracy: ≤ 1.0 % of span ± 1 digit Update: 1,000, 500, 200, 100 ms (adjustable)						

Performance

Non-linearity	≤ ± 0.5 % of span (Best Fit Straight Line, BFSL) according to IEC 61298-2
Accuracy	≤ ± 1 % of span Including non-linearity, hysteresis, zero point and full scale error (corresponds to error of measurement according to IEC 61298-2)
Response time	3 ms
Long-term drift/one-year stability	≤ ± 0.2 % of span according to IEC 61298-2
Temperature error	≤ 1.0 % of span typ., ≤ 2.5 % of span max.
Temperature coefficient in rated temperature range	Mean TC of zero: ≤ 0.2 % of span / 10 K Mean TC of span ≤ 0.2 % of span / 10 K
Rated temperature range	0 °C ... +80 °C
Service life	Minimum 10 mill. load cycles

Mechanics/electronics

Process connections	See type code
Wetted parts	Pressure connection: Stainless steel 316L Pressure sensor: Stainless steel 316L (for measurement ranges from 0 bar ... 10 bar rel. stainless steel 13-8 PH)
Internal transmission fluid	Silicone oil (only with pressure ranges < 0 bar ... 10 bar and ≤ 0 bar abs ... 25 bar abs)
Pressure peak dampening	Through optional integrated pressure port 0.6 mm or 0.3 mm for process connector G ¼ according to DIN 3852-E (0.3 mm from 10 bar)
Pressure port	3.5 mm (standard)
Housing material	Lower body: Stainless steel 304, plastic head: PC + ABS, buttons: TPE-E, display window: PC

¹⁾ Enclosure rating IP per IEC 60529. The enclosure rating classes specified only apply while the pressure transmitter is connected with female connectors that provide the corresponding enclosure rating.

Electrical connection/enclosure rating ¹⁾	Plug connector M12 x 1, 4-pin, IP 65 / 67 with 2 switching outputs or with 1 switching output + analog output Plug connector M12 x 1, 5-pin, IP 65 / 67 with 2 switching outputs and analog output
Supply voltage	15 V DC ... 35 V DC
Power consumption	45 mA (for configurations without analog output signal) 70 mA (for configurations with analog output signal)
Total current consumption	Max. 350 mA / 570 mA (incl. switching current)
Electrical safety	Protection class: III Overvoltage protection: 40 V DC Short-circuit protection: Q _A , Q ₁ , Q ₂ towards M Reverse polarity protection: L ⁺ towards M
Isolation voltage	500 V DC
CE-conformity	Pressure equipment directive: This instrument is a pressure accessory as defined by the directive 97/23/EC EMC directive: 2004/108/EEC, EN 61326-2-3
Weight sensor	Approx. 200 g

¹⁾ Enclosure rating IP per IEC 60529. The enclosure rating classes specified only apply while the pressure transmitter is connected with female connectors that provide the corresponding enclosure rating.

Ambient data

Ambient temperature	-20 °C ... +80 °C
Storage temperature	-20 °C ... +80 °C
Relative humidity	≤ 90 %
Shock load	50 g according to IEC 60068-2-27 (mechanical shock)
Vibration load	10 g according to IEC 60068-2-6 (vibration under resonance)

Ordering information

The part numbers below show a selection of our common configurations and represent only a portion of the product portfolio. The type code on page D-123 indicates all possible configurations that can be ordered.

Vacuum and ± measuring range

- **Pressure port:** Standard
- **Accuracy:** ≤ ± 1 % of span

Output signal	Electrical connection	Process connection	Seal	Measuring range	Model name	Part no.
2x PNP + 4 ... 20 mA	Round connector M12 x 1, 5-pin, IP 67	G ¼ A according to DIN 3852-E	NBR	-1 bar ... +9 bar	PBS-CB010SG1SSND5A0Z	6038922
				-1 bar ... +3 bar	PBS-CB4X0SG1SSND5A0Z	6038921
				-1 bar ... +1.5 bar	PBS-CB2X5SG1SSND5A0Z	6050311
				-1 bar ... 0 bar	PBS-CB1X0SG1SSND5A0Z	6038919
2 x PNP	Round connector M12 x 1, 4-pin, IP 67	¼" NPT	Without seal	-14.5 psi ... +160 psi	PBS-CP175SN1SS0AMA0Z	6044852
				-14.5 psi ... +25 psi	PBS-CP040SN1SS0AMA0Z	6048034
				-14.5 psi ... +15 psi	PBS-CP030SN1SS0AMA0Z	6047943
				-14.5 psi ... 0 psi	PBS-CP015SN1SS0AMA0Z	6042106
		G ¼ female	Without seal	-1 bar ... +9 bar	PBS-CB010SG2SS0AMA0Z	6041541
				-1 bar ... +3 bar	PBS-CB4X0SG2SS0AMA0Z	6041048
				-1 bar ... +1.5 bar	PBS-CB2X5SG2SS0AMA0Z	6050312
				-1 bar ... 0 bar	PBS-CB1X0SG2SS0AMA0Z	6042360
		G ¼ A according to DIN 3852-E	NBR	-1 bar ... +9 bar	PBS-CB010SG1SSNAMA0Z	6038870
				-1 bar ... +3 bar	PBS-CB4X0SG1SSNAMA0Z	6038869
				-1 bar ... +1.5 bar	PBS-CB2X5SG1SSNAMA0Z	6044336
				-1 bar ... 0 bar	PBS-CB1X0SG1SSNAMA0Z	6038868

Output signal	Electrical connection	Process connection	Seal	Measuring range	Model name	Part no.
1 x PNP + 4 ... 20 mA	Round connector M12 x 1, 4-pin, IP 67	G ¼ female	Without seal	-1 bar ... +9 bar	PBS-CB010SG2SS0BMA0Z	6041614
				-1 bar ... +3 bar	PBS-CB4X0SG2SS0BMA0Z	6042096
				-1 bar ... +1.5 bar	PBS-CB2X5SG2SS0BMA0Z	6042115
				-1 bar ... 0 bar	PBS-CB1X0SG2SS0BMA0Z	6047823
		G ¼ A according to DIN 3852-E	NBR	-1 bar ... +9 bar	PBS-CB010SG1SSNBMA0Z	6038896
				-1 bar ... +3 bar	PBS-CB4X0SG1SSNBMA0Z	6038895
				-1 bar ... +1.5 bar	PBS-CB2X5SG1SSNBMA0Z	6039523
				-1 bar ... 0 bar	PBS-CB1X0SG1SSNBMA0Z	6038894

Absolute pressure

- **Output signal:** 2x PNP
- **Seal:** NBR
- **Pressure port:** Standard
- **Accuracy:** $\leq \pm 1\%$ of span

Electrical connection	Process connection	Measuring range	Model name	Part no.
Round connector M12 x 1, 4-pin, IP 67	G ¼ A according to DIN 3852-E	0 bar ... 10 bar	PBS-AB016SG1SSNAMA0Z	6039775
		0 bar ... 2.5 bar	PBS-AB010SG1SSNAMA0Z	6048436
		0 bar ... 1 bar	PBS-AB2X5SG1SSNAMA0Z	6045253
		0 bar ... 16 bar	PBS-AB1X6SG1SSNAMA0Z	6039652
		0 bar ... 1.6 bar	PBS-AB1X0SG1SSNAMA0Z	6049474

Gauge pressure

- **Pressure port:** Standard
- **Accuracy:** $\leq \pm 1\%$ of span

Output signal	Electrical connection	Process connection	Seal	Measuring range	Model name	Part no.
IO-Link, 2x PNP	Round connector M12 x 1, 4-pin, IP 67	G ¼ female	Without seal	0 bar ... 400 bar	PBS-RB400SG2SS0LMA0Z	6045069
				0 bar ... 250 bar	PBS-RB250SG2SS0LMA0Z	6041626
				0 bar ... 100 bar	PBS-RB100SG2SS0LMA0Z	6041419
				0 bar ... 10 bar	PBS-RB010SG2SS0LMA0Z	6041418
				0 bar ... 1 bar	PBS-RB1X0SG2SS0LMA0Z	6050308
2x PNP + 4 ... 20 mA	Round connector M12 x 1, 5-pin, IP 67	G ¼ female	Without seal	0 bar ... 400 bar	PBS-RB400SG2SS0D5A0Z	6041595
				0 bar ... 250 bar	PBS-RB250SG2SS0D5A0Z	6041527
				0 bar ... 100 bar	PBS-RB100SG2SS0D5A0Z	6042526
				0 bar ... 10 bar	PBS-RB010SG2SS0D5A0Z	6039123
				0 bar ... 1 bar	PBS-RB1X0SG2SS0D5A0Z	6045265
		G ¼ A according to DIN 3852-E	NBR	0 bar ... 400 bar	PBS-RB400SG1SSND5A0Z	6042402
				0 bar ... 250 bar	PBS-RB250SG1SSND5A0Z	6038918
				0 bar ... 100 bar	PBS-RB100SG1SSND5A0Z	6038917
				0 bar ... 10 bar	PBS-RB010SG1SSND5A0Z	6038678
				0 bar ... 1 bar	PBS-RB1X0SG1SSND5A0Z	6038912

Output signal	Electrical connection	Process connection	Seal	Measuring range	Model name	Part no.
2 x PNP	Round connector M12 x 1, 4-pin, IP 67	G ¼ A according to DIN 3852-E	NBR	0 bar ... 400 bar	PBS-RB400SG1SSNAMA0Z	6041099
				0 bar ... 250 bar	PBS-RB250SG1SSNAMA0Z	6038866
				0 bar ... 100 bar	PBS-RB100SG1SSNAMA0Z	6038865
				0 bar ... 10 bar	PBS-RB010SG1SSNAMA0Z	6038862
				0 bar ... 1 bar	PBS-RB1X0SG1SSNAMA0Z	6038847
		G ½ B flush-mounted	NBR	0 bar ... 100 bar	PBS-CB4X0SN1SS0AMA0Z	6049161
				0 bar ... 16 bar	PBS-RB016SF2FSNAMA0Z	6049845
				0 bar ... 10 bar	PBS-RB025SG2SS0BMA0Z	6049071
				0 bar ... 2.5 bar	PBS-RB2X5SF2FSNAMA0Z	6050186
		G ¼ female	Without seal	0 bar ... 400 bar	PBS-RB400SG2SS0AMA0Z	6039495
				0 bar ... 250 bar	PBS-RB250SG2SS0AMA0Z	6039615
				0 bar ... 100 bar	PBS-RB100SG2SS0AMA0Z	6039614
				0 bar ... 10 bar	PBS-RB010SG2SS0AMA0Z	6039110
		¼" NPT	Without seal	0 bar ... 1 bar	PBS-RB1X0SG2SS0AMA0Z	6041777
				0 psi ... 5,000 psi	PBS-RP5K0SN1SS0AMA0Z	6048120
				0 psi ... 3,000 psi	PBS-RP3K0SN1SS0AMA0Z	6041560
				0 psi ... 1,500 psi	PBS-RP1K5SN1SS0AMA0Z	6048961
				0 psi ... 1,000 psi	PBS-RP1K0SN1SS0AMA0Z	6044565
				0 psi ... 500 psi	PBS-RP500SN1SS0AMA0Z	6048001
				0 psi ... 160 psi	PBS-RP160SN1SS0AMA0Z	6041223
0 psi ... 100 psi	PBS-RP100SN1SS0AMA0Z	6041222				
1 x PNP + 4 ... 20 mA	Round connector M12 x 1, 4-pin, IP 67	G ¼ A according to DIN 3852-E	NBR	0 bar ... 400 bar	PBS-RB400SG1SSNBMA0Z	6041724
				0 bar ... 250 bar	PBS-RB250SG1SSNBMA0Z	6038892
				0 bar ... 100 bar	PBS-RB100SG1SSNBMA0Z	6038891
				0 bar ... 10 bar	PBS-RB010SG1SSNBMA0Z	6038888
				0 bar ... 1 bar	PBS-RB1X0SG1SSNBMA0Z	6038885
		G ½ B flush mounted	NBR	0 bar ... 100 bar	PBS-RB100SF2FSNBMA0Z	6049761
				0 bar ... 16 bar	PBS-RB016SF2FSNBMA0Z	6050168
				0 bar ... 10 bar	PBS-RB010SF2FSNBMA0Z	6049686
				0 bar ... 2.5 bar	PBS-RB2X5SF2FSNBMA0Z	6049189
		G ¼ female	Without seal	0 bar ... 400 bar	PBS-RB400SG2SS0BMA0Z	6041019
				0 bar ... 250 bar	PBS-RB250SG2SS0BMA0Z	6041053
				0 bar ... 100 bar	PBS-RB100SG2SS0BMA0Z	6041615
				0 bar ... 10 bar	PBS-RB010SG2SS0BMA0Z	6039121
		¼" NPT	Without seal	0 bar ... 1 bar	PBS-RB1X0SG2SS0BMA0Z	6041279
				0 psi ... 5,000 psi	PBS-RP5K0SN1SS0BMA0Z	6050310
				0 psi ... 3,000 psi	PBS-RP3K0SN1SS0BMA0Z	6049434
				0 psi ... 1,500 psi	PBS-RP1K5SN1SS0BMA0Z	6049723
				0 psi ... 1,000 psi	PBS-RP1K0SN1SS0BMA0Z	6041561
				0 psi ... 500 psi	PBS-RP500SN1SS0BMA0Z	6041562
				0 psi ... 160 psi	PBS-RP160SN1SS0BMA0Z	6050309
0 psi ... 100 psi	PBS-RP100SN1SS0BMA0Z	6043695				

D

Type code

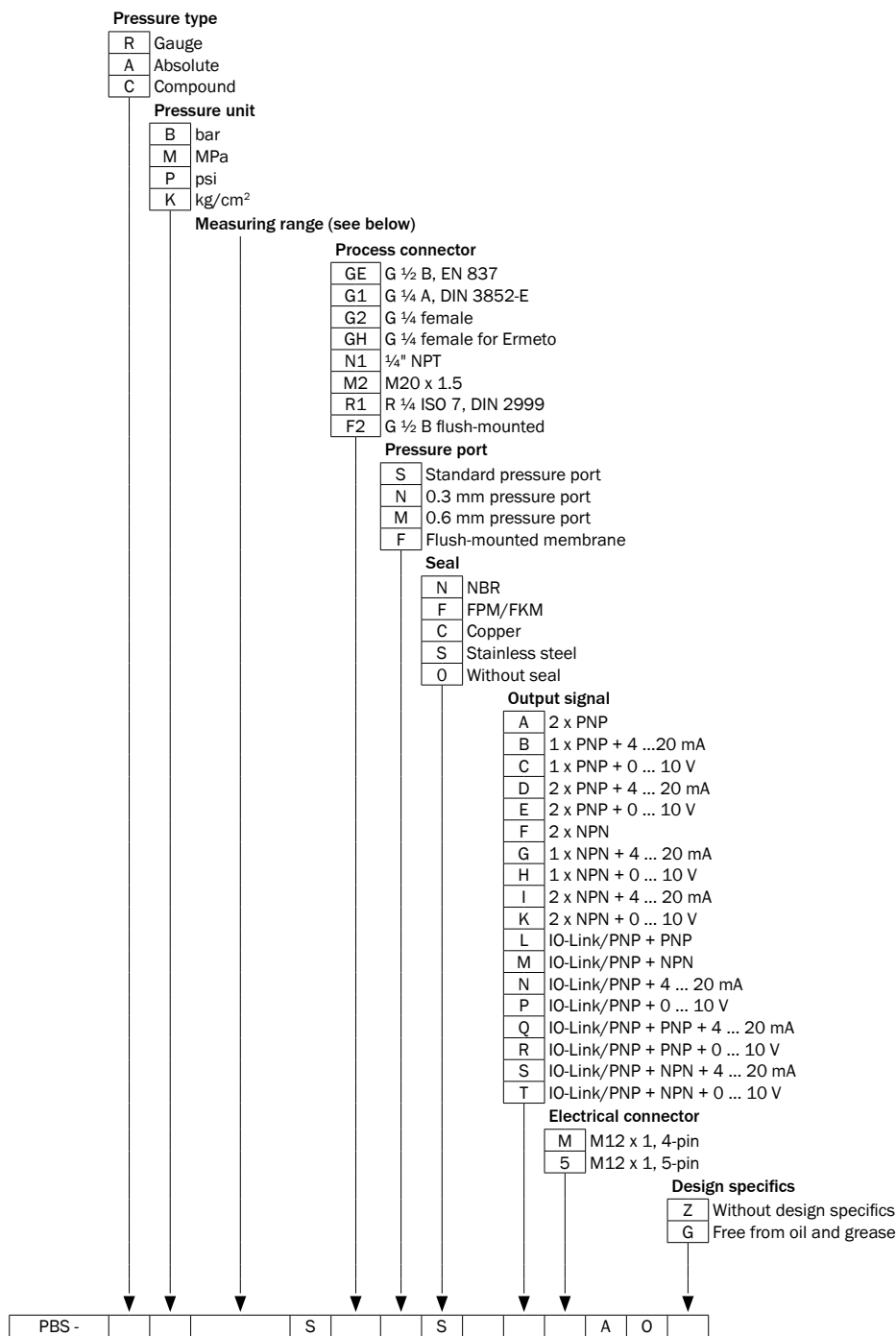

Not all variations of the type code can be combined!

Measuring ranges

	Gauge pressure	Overpressure safety
1X0	0 ... 1 bar	2 bar
1X6	0 ... 1.6 bar	3.2 bar
2X5	0 ... 2.5 bar	5 bar
4X0	0 ... 4 bar	8 bar
6X0	0 ... 6 bar	12 bar
010	0 ... 10 bar	20 bar
016	0 ... 16 bar	32 bar
025	0 ... 25 bar	50 bar
040	0 ... 40 bar	80 bar
060	0 ... 60 bar	120 bar
100	0 ... 100 bar	200 bar
160	0 ... 160 bar	320 bar
250	0 ... 250 bar	500 bar
400	0 ... 400 bar	800 bar
600	0 ... 600 bar	1,200 bar

	Absolute pressure	Overpressure safety
1X0	0 ... 1 bar abs	2 bar abs
1X6	0 ... 1.6 bar abs	3.2 bar abs
2X5	0 ... 2.5 bar abs	5 bar abs
4X0	0 ... 4 bar abs	8 bar abs
6X0	0 ... 6 bar abs	12 bar abs
010	0 ... 10 bar abs	20 bar abs
016	0 ... 16 bar abs	32 bar abs
025	0 ... 25 bar abs	50 bar abs

	Compound pressure	Overpressure safety
1X0	-1 ... 0 bar	2 bar
2X5	-1 ... +1.5 bar	3 bar
4X0	-1 ... +3 bar	6 bar
6X0	-1 ... +5 bar	10 bar
010	-1 ... +9 bar	18 bar
016	-1 ... +15 bar	30 bar
025	-1 ... +24 bar	48 bar

	Gauge pressure	Overpressure safety
015	0 ... 15 psi	30 psi
025	0 ... 25 psi	60 psi
030	0 ... 30 psi	60 psi
050	0 ... 50 psi	100 psi
100	0 ... 100 psi	200 psi
160	0 ... 160 psi	320 psi
200	0 ... 200 psi	400 psi
300	0 ... 300 psi	600 psi
500	0 ... 500 psi	1,000 psi
1K0	0 ... 1,000 psi	2,000 psi
1K5	0 ... 1,500 psi	3,000 psi
2K0	0 ... 2,000 psi	4,000 psi
3K0	0 ... 3,000 psi	6,000 psi
5K0	0 ... 5,000 psi	10,000 psi
8K0	0 ... 8,000 psi	16,000 psi

	Absolute pressure	Overpressure safety
015	0 ... 15 psi abs	30 psi abs
025	0 ... 25 psi abs	60 psi abs
030	0 ... 30 psi abs	60 psi abs
050	0 ... 50 psi abs	100 psi abs
100	0 ... 100 psi abs	200 psi abs
160	0 ... 160 psi abs	290 psi abs
200	0 ... 200 psi abs	400 psi abs
300	0 ... 300 psi abs	600 psi abs

	Compound pressure	Overpressure safety
015	-14.5 ... +0 psi	30 psi
030	-14.5 ... +15 psi	30 psi
040	-14.5 ... +25 psi	50 psi
045	-14.5 ... +30 psi	60 psi
065	-14.5 ... +50 psi	100 psi
115	-14.5 ... +100 psi	200 psi
175	-14.5 ... +160 psi	320 psi
215	-14.5 ... +200 psi	400 psi
315	-14.5 ... +300 psi	600 psi

D

Dimensional drawings

PBS

dimensions in mm (inch)

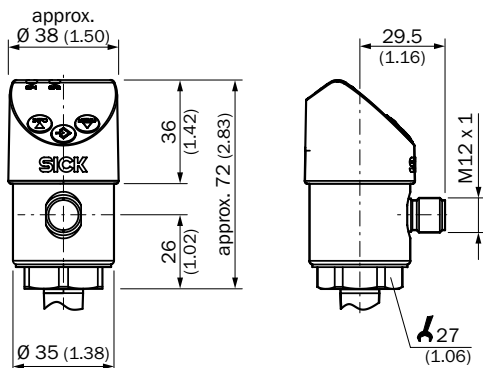

G 1/2 B according to EN 837

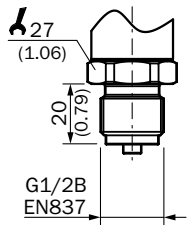

G 1/4 A DIN 3852-E

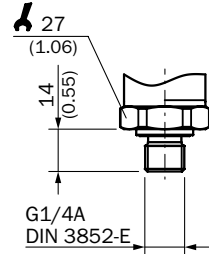

G 1/4 female EN 837

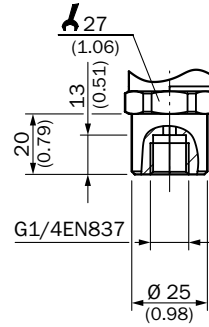

G 1/4 female, compatible with Ermeto

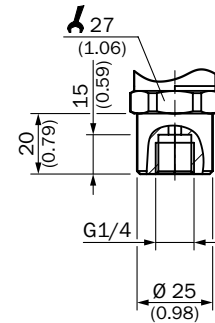

1/4" NPT

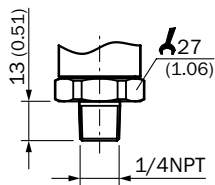

M20 x 1.5

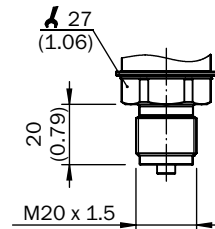

R 1/4 ISO 7

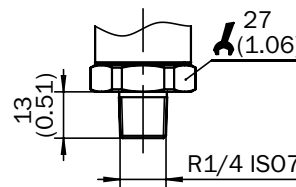

G 1/2 B flush-mounted

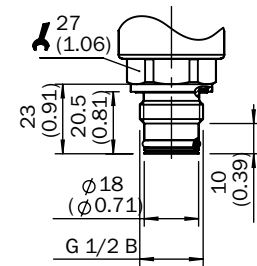

Recommended accessories

Mounting brackets/plates

	Brief description	Model name	Part no.
	Mounting bracket for simple and stable wall mounting of pressure sensors with 27 mm hexagon, material: Aluminium	BEF-FL-ALUPBS-HLDR	5322501

Device protection (mechanical)

	Brief description	Model name	Part no.
	Cooling element, extension of the process temperature up to 150 °C. Maximum ambient temperature 30 °C. Max. process pressure 200 bar. Not suitable for pressure measurement in steam. Outer thread G 1/2, inner thread G 1/2. Material: Stainless steel 1.4571	BEF-CE-G12G12-150C	5324393
	Cooling element, extension of the process temperature up to 200 °C. Maximum ambient temperature 30 °C. Max. process pressure 200 bar. Not suitable for pressure measurement in steam. Outer thread G 1/2, inner thread G 1/2. Material: Stainless steel 1.4571	BEF-CE-G12G12-200C	5324394

Others

	Brief description	Enclosure rating	Model name	Part no.
	IO-Link-Master	IP 65, IP 67	IOLSHPB-P3104R01	6039728



All-around pressure transmitter



Product description

The PBT is a universal electronic pressure transmitter used in general industrial applications for pressure measurement of liquid and gaseous fluids. The PBT is SICK's pressure transmitter for standard applications in machine tools, control systems, hydraulics, pneumatics, etc. The PBT

is available in a wide selection of configurations, enabling a perfect match to individual customer requirements. Its precise and robust measurement technology, compact dimensions and quick and simple installation distinguish the PBT as a real all-around solution.

At a glance

- Pressure measurement ranges from 0 bar ... 1 bar up to 0 bar ... 600 bar
- Gauge, absolute and compound measurement ranges
- A wide range of available process connections
- No moving parts: No mechanical wear, fatigue-proof, maintenance-free
- Circularly welded, hermetically sealed stainless steel membrane
- Output signal 4 mA ... 20 mA, 0 V ... 5 V or 0 V ... 10 V
- Electrical connection M12 x 1, L-connector acc. to DIN 175301-803 A or flying leads

Your benefits

- Compact size takes up less space
- Simple and cost-saving installation
- Available in a wide selection of configurations, enabling a perfect match to individual customer requirements
- Robust design enables higher reliability
- Excellent price/performance ratio



Additional information

- Detailed technical data.D-127
- Ordering information.D-128
- Type code.D-131
- Dimensional drawingsD-133
- Recommended accessories. . . .D-134

→ www.mysick.com/en/PBT

For more information, just enter the link or scan the QR code and get direct access to technical data, CAD design models, operating instructions, software, application examples and much more.



D

Detailed technical data

Features

Pressure units	bar, MPa, psi and kg/cm ²
Measuring ranges	
Gauge pressure	0 bar ... 1 bar up to 0 bar ... 600 bar
Absolute pressure	0 bar ... 1 bar up to 0 bar ... 25 bar
Compound pressure	-1 bar ... 0 bar up to -1 bar ... +24 bar
Process temperature	0 °C ... +80 °C, optional -30 °C ... +100 °C
Signal output and maximum ohmic load R_A	4 mA ... 20 mA, 2-wire (R _A ≤ (L ⁺ - 8 V) / 0.02 A [Ohm]) 0 V ... 10 V, 3-wire (R _A > 10 kOhm) 0 V ... 5 V, 3-wire (R _A > 5 kOhm)

Performance

Non-linearity	≤ ± 0.5 % of span (Best Fit Straight Line, BFSL) according to IEC 61298-2 ≤ ± 0.25 % of span (Best Fit Straight Line, BFSL) according to IEC 61298-2 (optional) Adjusted in vertical mounting position with pressure connection facing downwards
Accuracy	≤ ± 0.5 % of span (with non-linearity 0.25 %) ≤ ± 0.6 % of span (with non-linearity 0.25 % and with signal output 0 ... 5 V) ≤ ± 1.0 % of span (with non-linearity 0.5 %) Including non-linearity, hysteresis, zero point and full scale error (corresponds to error of measurement according to IEC 61298-2)
Adjustment accuracy of zero signal	≤ 0.15 % of span typ., ≤ 0.4 % of span max. (with non-linearity 0.25 %) ≤ 0.5 % of span typ., ≤ 0.8 % of span max. (with non-linearity 0.5 %)
Hysteresis	≤ 0.16 % of span
Non-repeatability	≤ 0.1 % of span
Response time	< 4 ms
Signal noise	≤ 0.3 % of span
Long-term drift/one-year stability	≤ 0.1 % of span according to IEC 61298-2
Temperature error	≤ 1.0 % of span typ., ≤ 2.5 % of span max.
Rated temperature range	0 °C ... +80 °C
Service life	Minimum 10 mill. load cycles

Mechanics/electronics

Process connections	See type code
Wetted parts	Pressure connection: Stainless steel 316L Pressure sensor: Stainless steel 316L (from 0 bar ... 10 bar rel., stainless steel 13-8 PH)
Internal transmission fluid	Silicone oil (only with pressure ranges < 0 bar ... 10 bar and ≤ 0 bar abs ... 25 bar abs)
Pressure peak dampening	Through optional integrated pressure port 0.6 mm or 0.3 mm for process connector G ¼ according to DIN 3852-E (0.3 mm from 10 bar)
Pressure port	3.5 mm (standard)
Housing material	Stainless steel 316L
Electrical connection/enclosure rating ¹⁾	Round connector M12 x 1, 4-pin, IP 67 L-connector (DIN EN 175301-803 A), IP 65 Flying leads 2 m / 5 m, IP 67
Supply voltage ²⁾	8 V DC ... 35 V DC with output signal 4 mA ... 20 mA and 0 V ... 5 V, 14 V DC ... 35 V DC with output signal 0 V ... 10 V
Power consumption	Signal current (max. 25 mA) for current output Max. 8 mA for voltage output signal

¹⁾ Enclosure rating IP per IEC 60529. The enclosure rating classes specified only apply while the pressure transmitter is connected with female connectors that provide the corresponding enclosure rating.

²⁾ Electrical circuit in accordance with section 9.3 of UL/EN/IEC 61010-1 or an LPS to UL/EN/ IEC 60950-1 or class 2 in accordance with UL 1310/UL 1585 (NEC or CEC). The power supply must be suitable for operation above 2,000 m should the pressure transmitter be used at this altitude.

Electrical safety	Overvoltage protection: 32 V DC, 36 V DC with 4 mA ... 20 mA Short-circuit protection: Q _A towards M Reverse polarity protection: L* towards M Protection class: III
Isolation voltage	500 V DC
CE-conformity	Pressure equipment directive: 97/23/EC, EMC directive: 2004/108/EC, EN 61 326-2-3
Weight sensor	Approx. 80 g
Reference conditions	Reference conditions: According to IEC 61298-1

¹⁾ Enclosure rating IP per IEC 60529. The enclosure rating classes specified only apply while the pressure transmitter is connected with female connectors that provide the corresponding enclosure rating.

²⁾ Electrical circuit in accordance with section 9.3 of UL/EN/IEC 61010-1 or an LPS to UL/EN/ IEC 60950-1 or class 2 in accordance with UL 1310/UL 1585 (NEC or CEC). The power supply must be suitable for operation above 2,000 m should the pressure transmitter be used at this altitude.

Ambient data

Ambient temperature	0 °C ... +80 °C -30 °C ... +100 °C optional
Storage temperature	-20 °C ... +80 °C -30 °C ... +100 °C optional
Relative humidity	45 % ... 75 %
Shock load	500 g according to IEC 60068-2-27 (mechanical shock)
Vibration load	10 g according to IEC 60068-2-6 (vibration under resonance) 20 g optional

Ordering information

The part numbers below show a selection of our common configurations and represent only a portion of the product portfolio. The type code on page D-131 indicates all possible configurations that can be ordered.

Absolute pressure

- **Pressure port:** Standard
- **Accuracy:** $\leq \pm 1 \%$
- **Electrical connection:** round connector M12 x 1, 4-pin, IP 67

D

Output signal	Process connection	Seal	Measuring range	Model name	Part no.
4 mA ... 20 mA	G ¼ A according to DIN 3852-E	NBR	0 bar ... 16 bar	PBT-AB016SG1SSNAMA0Z	6045296
			0 bar ... 10 bar	PBT-AB010SG1SSNAMA0Z	6038689
			0 bar ... 2.5 bar	PBT-AB2X5SG1SSNAMA0Z	6038685
			0 bar ... 1.6 bar	PBT-AB1X6SG1SSNAMA0Z	6039852
			0 bar ... 1 bar	PBT-AB1X0SG1SSNAMA0Z	6038683

Gauge pressure

- Accuracy: $\leq \pm 1\%$
- Pressure port: Standard

Output signal	Electrical connection	Process connection	Seal	Measuring range	Model name	Part no.
4 mA ... 20 mA, 2-wire	L-connector (DIN EN 175301-803 A), IP 65	¼" NPT	Without seal	0 bar ... 400 bar	PBT-RB400SN1SS0ALAOZ	6049488
				0 bar ... 250 bar	PBT-RB250SN1SS0ALAOZ	6049698
				0 bar ... 10 bar	PBT-RB010SN1SS0ALAOZ	6042137
				0 bar ... 1 bar	PBT-RB1X0SN1SS0ALAOZ	6049386
		G ¼ A according to DIN 3852-E	NBR	0 bar ... 400 bar	PBT-RB400SG1SSNALAOZ	6041553
				0 bar ... 250 bar	PBT-RB250SG1SSNALAOZ	6041438
				0 bar ... 100 bar	PBT-RB100SG1SSNALAOZ	6041999
				0 bar ... 10 bar	PBT-RB010SG1SSNALAOZ	6040974
	Round connector M12 x 1, 4-pin, IP 67	¼" NPT	Without seal	0 psi ... 5,000 psi	PBT-RP5K0SN1SS0AMAOZ	6045110
				0 psi ... 3,000 psi	PBT-RP3K0SN1SS0AMAOZ	6041557
				0 psi ... 1,000 psi	PBT-RP1K0SN1SS0AMAOZ	6041558
				0 psi ... 500 psi	PBT-RP500SN1SS0AMAOZ	6041559
				0 psi ... 160 psi	PBT-RP160SN1SS0AMAOZ	6045109
				0 psi ... 100 psi	PBT-RP100SN1SS0AMAOZ	6049897
		G ¼ female	Without seal	0 bar ... 400 bar	PBT-RB400SN1SS0AMAOZ	6042070
				0 bar ... 250 bar	PBT-RB250SN1SS0AMAOZ	6042527
				0 bar ... 100 bar	PBT-RB100SN1SS0AMAOZ	6042006
				0 bar ... 10 bar	PBT-RB010SN1SS0AMAOZ	6039256
				0 bar ... 1 bar	PBT-RB1X0SN1SS0AMAOZ	6043720
				0 bar ... 400 bar	PBT-RB400SG2SS0AMAOZ	6038657
	G ¼ A according to DIN 3852-E	NBR	0 bar ... 250 bar	PBT-RB250SG2SS0AMAOZ	6038653	
			0 bar ... 100 bar	PBT-RB100SG2SS0AMAOZ	6038649	
			0 bar ... 10 bar	PBT-RB010SG2SS0AMAOZ	6038637	
			0 bar ... 1 bar	PBT-RB1X0SG2SS0AMAOZ	6038717	
			0 bar ... 400 bar	PBT-RB400SG1SSNAMA0Z	6038656	
			0 bar ... 250 bar	PBT-RB250SG1SSNAMA0Z	6038652	
			0 bar ... 100 bar	PBT-RB100SG1SSNAMA0Z	6038648	
			0 bar ... 10 bar	PBT-RB010SG1SSNAMA0Z	6038615	
0 bar ... 1 bar	PBT-RB1X0SG1SSNAMA0Z	6038716				



Output signal	Electrical connection	Process connection	Seal	Measuring range	Model name	Part no.
0...10 V, 3-wire	L-connector (DIN EN 175301-803 A), IP 65	G ¼ A according to DIN 3852-E	NBR	0 bar ... 250 bar	PBT-RB250SG1SSNVLC0Z	6047659
				0 bar ... 100 bar	PBT-RB100SG1SSNVLC0Z	6047878
				0 bar ... 400 bar	PBT-RB400SG1SSNVLC0Z	6039721
				0 bar ... 10 bar	PBT-RB010SG1SSNVLC0Z	6042101
				0 bar ... 1 bar	PBT-RB1X0SG1SSNVLC0Z	6043989
	Round connector M12 x 1, 4-pin, IP 67	G ¼ female	Without seal	0 bar ... 400 bar	PBT-RB400SG2SS0VMC0Z	6038659
				0 bar ... 250 bar	PBT-RB250SG2SS0VMC0Z	6038655
				0 bar ... 100 bar	PBT-RB100SG2SS0VMC0Z	6038651
				0 bar ... 10 bar	PBT-RB010SG2SS0VMC0Z	6038639
				0 bar ... 1 bar	PBT-RB1X0SG2SS0VMC0Z	6038628
		G ¼ A according to DIN 3852-E	NBR	0 bar ... 400 bar	PBT-RB400SG1SSNVMC0Z	6038658
				0 bar ... 250 bar	PBT-RB250SG1SSNVMC0Z	6038654
				0 bar ... 100 bar	PBT-RB100SG1SSNVMC0Z	6038650
				0 bar ... 10 bar	PBT-RB010SG1SSNVMC0Z	6038638
			0 bar ... 1 bar	PBT-RB1X0SG1SSNVMC0Z	6038627	

Compound pressure

- **Pressure port:** Standard
- **Accuracy:** $\leq \pm 1\%$ of span
- **Electrical connection:** Round connector M12 x 1, 4-pin, IP 67
- **Process connection:** G ¼ A according to DIN 3852-E
- **Seal:** NBR

Output signal	Measuring range	Model name	Part no.
4 mA ... 20 mA, 2-wire	-1 bar ... +9 bar	PBT-CB010SG1SSNAMA0Z	6038693
	-1 bar ... +5 bar	PBT-CB6X0SG1SSNAMA0Z	6042847
	-1 bar ... +3 bar	PBT-CB4X0SG1SSNAMA0Z	6042117
	-1 bar ... 0 bar	PBT-CB1X0SG1SSNAMA0Z	6040917
0 V ... 10 V, 3-wire	-1 bar ... +9 bar	PBT-CB010SG1SSNVMC0Z	6038694
	-1 bar ... 0 bar	PBT-CB1X0SG1SSNVMC0Z	6043710
	-1 bar ... +3 bar	PBT-CB4X0SG1SSNVMC0Z	6048013
	-1 bar ... +1.5 bar	PBT-CB2X5SG1SSNVMC0Z	6049035

D

Measuring ranges

	Gauge pressure	Overpressure safety
1X1	0 ... 1 bar	2 bar
1X6	0 ... 1.6 bar	3.2 bar
2X5	0 ... 2.5 bar	5 bar
4X0	0 ... 4 bar	8 bar
6X0	0 ... 6 bar	12 bar
010	0 ... 10 bar	20 bar
016	0 ... 16 bar	32 bar
025	0 ... 25 bar	50 bar
040	0 ... 40 bar	80 bar
060	0 ... 60 bar	120 bar
100	0 ... 100 bar	200 bar
160	0 ... 160 bar	320 bar
250	0 ... 250 bar	500 bar
400	0 ... 400 bar	800 bar
600	0 ... 600 bar	1,200 bar

	Absolute pressure	Overpressure safety
1X0	0 ... 1 bar abs	2 bar abs
1X6	0 ... 1.6 bar abs	3.2 bar abs
2X5	0 ... 2.5 bar abs	5 bar abs
4X0	0 ... 4 bar abs	8 bar abs
6X0	0 ... 6 bar abs	12 bar abs
010	0 ... 10 bar abs	20 bar abs
016	0 ... 16 bar abs	32 bar abs
025	0 ... 25 bar abs	50 bar abs

	Compound pressure	Overpressure safety
1X0	-1 ... 0 bar	2 bar
1X6	-1 ... +0.6 bar	3.2 bar
2X5	-1 ... +1.5 bar	5 bar
4X0	-1 ... +3 bar	8 bar
6X0	-1 ... +5 bar	12 bar
010	-1 ... +9 bar	20 bar
016	-1 ... +15 bar	32 bar
025	-1 ... +24 bar	50 bar

	Gauge pressure	Overpressure safety
015	0 ... 15 psi	30 psi
025	0 ... 25 psi	60 psi
030	0 ... 30 psi	60 psi
050	0 ... 50 psi	100 psi
100	0 ... 100 psi	200 psi
160	0 ... 160 psi	290 psi
200	0 ... 200 psi	400 psi
300	0 ... 300 psi	600 psi
500	0 ... 500 psi	1,000 psi
1K0	0 ... 1,000 psi	1,740 psi
1K5	0 ... 1,500 psi	2,900 psi
2K0	0 ... 2,000 psi	4,000 psi
3K0	0 ... 3,000 psi	6,000 psi
5K0	0 ... 5,000 psi	10,000 psi
8K0	0 ... 8,000 psi	17,400 psi

	Absolute pressure	Overpressure safety
015	0 ... 15 psi abs	30 psi abs
025	0 ... 25 psi abs	60 psi abs
030	0 ... 30 psi abs	60 psi abs
050	0 ... 50 psi abs	100 psi abs
100	0 ... 100 psi abs	200 psi abs
150	0 ... 150 psi abs	290 psi abs
200	0 ... 200 psi abs	400 psi abs
300	0 ... 300 psi abs	600 psi abs

	Compound pressure	Overpressure safety
015	-14.5 ... +0 psi	30 psi
030	-14.5 ... +15 psi	60 psi
045	-14.5 ... +25 psi	100 psi
075	-14.5 ... +30 psi	200 psi
115	-14.5 ... +100 psi	290 psi
175	-14.5 ... +160 psi	400 psi
215	-14.5 ... +200 psi	400 psi
315	-14.5 ... +300 psi	600 psi

D

Dimensional drawings

dimensions in mm (inch)

Housing with circular connector M12 x 1, IP 67

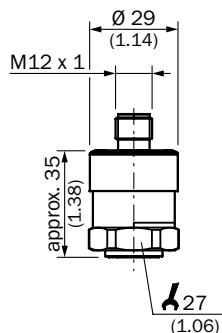

Housing with L-connector (DIN 175301-803 A), IP 65

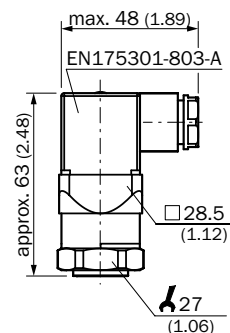

G 1/4 B EN 837

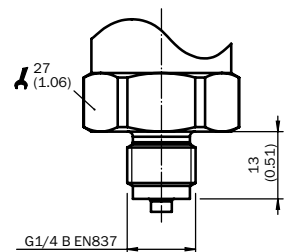

G 1/4 A DIN 3852-E

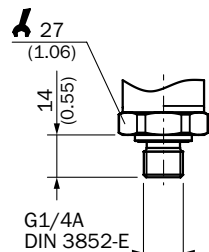

G 1/4 female EN 837

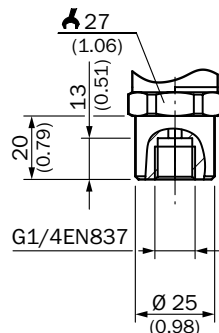

G 3/8 B EN 837

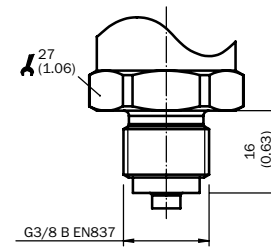

G 1/2 B according to EN 837

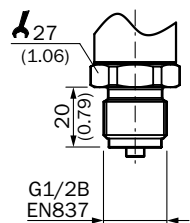

G 1/2 A according to DIN 3852-E

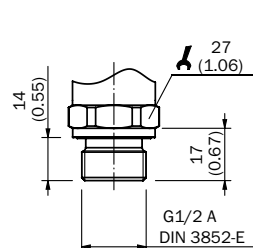

1/4" NPT

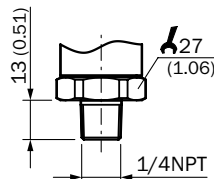

1/4" NPT female

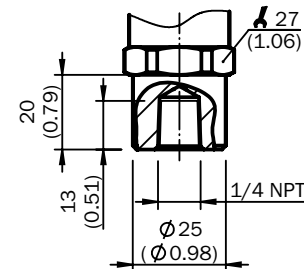

M20 x 1.5

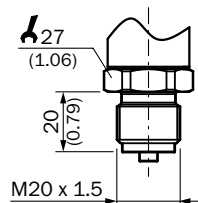

7/16" -20 UNF

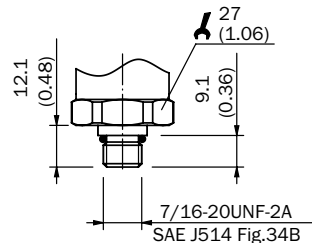

R 1/4 ISO 7

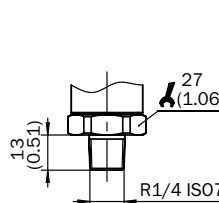



Recommended accessories

Mounting brackets/plates





	Brief description	Model name	Part no.
	Mounting bracket for simple and stable wall mounting of pressure sensors with 27 mm hexagon, material: Aluminium	BEF-FL-ALUPBS-HLDR	5322501

Device protection (mechanical)

	Brief description	Model name	Part no.
	Cooling element, extension of the process temperature up to 150 °C. Maximum ambient temperature 30 °C. Max. process pressure 200 bar. Not suitable for pressure measurement in steam. Outer thread G 1/2, inner thread G 1/2. Material: Stainless steel 1.4571	BEF-CE-G12G12-150C	5324393
	Cooling element, extension of the process temperature up to 200 °C. Maximum ambient temperature 30 °C. Max. process pressure 200 bar. Not suitable for pressure measurement in steam. Outer thread G 1/2, inner thread G 1/2. Material: Stainless steel 1.4571	BEF-CE-G12G12-200C	5324394

Plug connectors and cables

- Connector type: Cable socket
- Connection type: M12, 4-pin

	Enclosure rating	Sheath material	Cable outlet	Cable length	Model name	Part no.
	IP 67	PVC	Straight	2 m	DOL-1204-G02M	6009382
				5 m	DOL-1204-G05M	6009866
				10 m	DOL-1204-G10M	6010543
				15 m	DOL-1204-G15M	6010753
				20 m	DOL-1204-G20M	6034401
			Angled	2 m	DOL-1204-W02M	6009383
				5 m	DOL-1204-W05M	6009867
				10 m	DOL-1204-W10M	6010541
				15 m	DOL-1204-W15M	6036474
				20 m	DOL-1204-W20M	6033559
	IP 68	PUR halogen free	Straight	2 m	DOL-1204-G02MC	6025900
				5 m	DOL-1204-G05MC	6025901
				10 m	DOL-1204-G10MC	6025902
				15 m	DOL-1204-G15MC	6034749
				20 m	DOL-1204-G20MC	6034750
			Angled	2 m	DOL-1204-W02MC	6025903
				5 m	DOL-1204-W05MC	6025904
				10 m	DOL-1204-W10MC	6025905
				15 m	DOL-1204-W15MC	6034752
				20 m	DOL-1204-W20MC	6034753
				25 m	DOL-1204-W25MC	6034754

D



The flexible solution



Product description

The PFT electronic pressure transmitter is designed for precise pressure measurement for liquids and gases. Distinguished by its high-quality measurement technology, the device is well-suited to handle demanding measurement tasks in industrial

applications. Versions with extended temperature range, enhanced measurement accuracy or flush-mounted membrane open up a wide range of applications. Its vast configurability ensures the PFT can perfectly suit the most diverse customer requirements.

At a glance

- Measurement ranges from 0 mbar ... 100 mbar up to 0 bar ... 600 bar
- Gauge, absolute and compound measurement ranges
- Variant with flush-mounted membrane available
- Process temperature up to 150 °C (optional)
- Large variety of commonly used process connections
- High shock and vibration resistance
- Accuracy 0.5 % or 0.25 %
- Output signal 4 mA ... 20 mA, 0 V ... 5 V or 0 V ... 10 V
- Zero and span adjustable
- Electrical connection M12 x 1, L-connector according to DIN 175301-803 A or flying leads

Your benefits

- Reliable and highly accurate measurement technology
- Wide application range
- No mechanical wear, fatigue-proof, maintenance-free as no moving parts
- Simple and cost-saving installation
- Optimal solution for individual requirements due to very versatile configurability



Additional information

Detailed technical data.	D-137
Ordering information.	D-138
Type code.	D-140
Dimensional drawings	D-142
Recommended accessories.	D-143

→ www.mysick.com/en/PFT

For more information, just enter the link or scan the QR code and get direct access to technical data, CAD design models, operating instructions, software, application examples and much more.



Detailed technical data

Features

Pressure units	bar, MPa, psi and kg/cm ²
Measuring ranges	
Gauge pressure	0 bar ... 0.1 bar up to 0 bar ... 600 bar
Absolute pressure	0 bar ... 0.25 bar up to 0 bar ... 25 bar
Compound pressure	-1 bar ... 0 bar up to -1 bar ... +30 bar
Process temperature ¹⁾	-30 °C ... +100 °C -30 °C ... +70 °C With flush-mounted membrane and integrated cooling section : -20 °C ... +150 °C
Signal output and maximum ohmic load R_A	4 mA ... 20 mA, 2-wire (R _A ≤ (L ⁺ - 10 V) / 0.02 A [Ohm]) 0 V ... 5 V, 3-wire (R _A > 5 kOhm) 0 V ... 10 V, 3-wire (R _A > 10 kOhm)
Zero and span adjustment	± 5 % adjustability zero/span using potentiometers inside the instrument (not for flying leads with enclosure rating IP 68)

¹⁾ For flush-mounted membrane: The process temperature is limited to -30 °C ... +70 °C for measurement ranges 0 ... 400 bar and 0 ... 600 bar.

Performance

Non-linearity	≤ ± 0.2 % of span (Best Fit Straight Line, BFSL) according to IDC 61298-2
Accuracy	≤ ± 0.5 % of span ≤ ± 0.25 % of span (optionally available for pressure ranges ≥ 0.25 bar). Including non-linearity, hysteresis, zero point and full scale error (corresponds to error of measurement per IEC 61298-2) Calibrated vertically with pressure connector facing downwards
Non-repeatability	≤ ± 0.1 % of span
Response time (10 % ... 90 %)	≤ 1 ms (≤ 10 ms at medium temperatures below < -30 °C for pressure ranges up to 25 bar or with flush-mounted membrane)
Long-term drift/one-year stability	≤ ± 0.2 % of span (at reference conditions)
Temperature coefficient in rated temperature range	Mean TC of zero: ≤ 0.2 % of span / 10 K (< 0.4 % for pressure ranges ≤ 0.25 bar) Mean TC of span ≤ 0.2 % of span / 10 K
Rated temperature range	0 °C ... +80 °C

Mechanics/electronics

Process connections	See type code
Wetted parts	Standard membrane: Stainless steel 1.4571, stainless steel 1.4534 for measuring ranges > 25 bar Flush-mounted membrane: Stainless steel 1.4571 with NBR O-ring or FKM O-ring (FKM with integrated cooling element)
Internal transmission fluid	Synthetic oil (not available for version with standard membrane for pressure ranges > 25 bar)
Pressure peak dampening	Through optional integrated pressure port 0.6 mm or 0.3 mm for process connector G ¼ according to DIN 3852-E
Pressure port	3.5 mm Standard
Housing material	Stainless steel 1.4571
Electrical connection/ enclosure rating ¹⁾	Round connector M12 x 1, 4-pin, IP 67 L-connector (DIN EN 175301-803 A), IP 65 Flying leads, 1.5 m/ 3 m, IP 67 Flying leads, 1.5 m/ 3 m, IP 68 (zero and span not adjustable)
Supply voltage	10 V DC ... 30 V DC 14 V DC ... 30 V DC with output signal 0 V ... 10 V

¹⁾ Enclosure rating IP per IEC 60529. The enclosure rating classes specified only apply while the pressure transmitter is connected with female connectors that provide the corresponding enclosure rating.

Electrical safety	Overvoltage protection: 36 V DC Short-circuit protection: Q_A towards M Reverse polarity protection: L^+ towards M Protection class: III
Dielectric strength	500 V DC NEC Class 02 power supply (low voltage and low current max. 100 VA even under fault conditions)
CE-conformity	Pressure equipment directive: 97/23/EC, EMC directive: 2004/108/EEC, EN 61326-2-3
Weight sensor	Approx. 200 g

¹⁾ Enclosure rating IP per IEC 60529. The enclosure rating classes specified only apply while the pressure transmitter is connected with female connectors that provide the corresponding enclosure rating.

Ambient data

Ambient temperature	-20 °C ... +80 °C
Storage temperature	-40 °C ... +100 °C with flush-mounted membrane and cooling element -20 °C ... +100 °C
Shock load	1,000 g according to IEC 60068-2-27 (mechanical shock) 400 g according to IEC 60068-2-27 (mechanical shock) for version with integrated cooling element
Vibration load	20 g according to IEC 60068-2-6 (vibration under resonance) 10 g according to IEC 60068-2-6 (vibration under resonance) for version with integrated cooling element

Ordering information

The part numbers below show a selection of our common configurations and represent only a portion of the product portfolio. The type code on page D-140 indicates all possible configurations that can be ordered.

Absolute pressure

- **Output signal:** 4 mA ... 20 mA
- **Electrical connection:** Round connector M12 x 1, 4-pin, IP 67
- **Seal:** Without seal
- **Pressure port:** Standard
- **Accuracy:** $\leq \pm 0.5$ % of span

Process connection	Measuring range	Model name	Part no.
G ¼ female	0 bar ... 0.25 bar	PFT-SABX25SG2SSAAMSSZ	6038759
G ¼ A according to DIN 3852-E	0 bar ... 25 bar	PFT-SAB025SG1SSAAMSSZ	6038778
	0 bar ... 10 bar	PFT-SAB010SG1SSAAMSSZ	6038774
	0 bar ... 4 bar	PFT-SAB4X0SG1SSAAMSSZ	6038770
	0 bar ... 2.5 bar	PFT-SAB2X5SG1SSAAMSSZ	6038766
	0 bar ... 1 bar	PFT-SAB1X0SG1SSAAMSSZ	6038762
	800 mbar ... 1,200 mbar	PFT-SAA400SG1SSAAMSSZ	6042515

Gauge pressure

- **Output signal:** 4 mA ... 20 mA
- **Electrical connection:** Round connector M12 x 1, 4-pin, IP 67
- **Seal:** NBR
- **Accuracy:** $\leq \pm 0.5$ % of span

Process connection	Measuring range	Pressure port	Model name	Part no.
G ¼ A according to DIN 3852-E	0 bar ... 400 bar	Standard	PFT-SRB400SG1SSAALSSZ	6043561
	0 bar ... 250 bar		PFT-SRB250SG1SSAALSSZ	6043559
	0 bar ... 100 bar		PFT-SRB100SG1SSAALSSZ	6043557

Process connection	Measuring range	Pressure port	Model name	Part no.
G ¼ A according to DIN 3852-E	0 bar ... 10 bar	Standard	PFT-SRB010SG1SSAALSSZ	6039861
	0 bar ... 0.1 bar		PFT-SRBX10SG1SSAALSSZ	6039514
¼" NPT	0 psi ... 160 psi		PFT-SRP160SN1SSAAMSSZ	6041282
	0 psi ... 15 psi		PFT-SRP015SN1SSAAMSSZ	6045250
	0 psi ... 30 psi		PFT-SRP030SN1SSAAMSSZ	6047977
G ½ B flush-mounted with O-ring	0 bar ... 400 bar		Flush-mounted membrane	PFT-FRB400SF2OSSAMSSZ
	0 bar ... 250 bar	PFT-FRB250SF2OSSAMSSZ		6038816
	0 bar ... 100 bar	PFT-FRB100SF2OSSAMSSZ		6038815
	0 bar ... 10 bar	PFT-FRB010SF2OSSAMSSZ		6038812
	0 bar ... 2.5 bar	PFT-FRB2X5SF2OSSAMSSZ		6038810
	0 bar ... 0.25 bar	PFT-FRBX25SF1OSSAMSSZ		6038818
G ¼ A according to DIN 3852-E	0 bar ... 600 bar	Standard	PFT-SRB600AG1SSAAMSSZ	6041578
	0 bar ... 400 bar		PFT-SRB400SG1SSAAMSSZ	6038594
	0 bar ... 1 bar		PFT-SRB1X0SG1SSAAMSSZ	6038723
	0 bar ... 10 bar		PFT-SRB010SG1SSAAMSSZ	6038735
	0 bar ... 250 bar		PFT-SRB250SG1SSAAMSSZ	6038750
	0 bar ... 100 bar		PFT-SRB100SG1SSAAMSSZ	6038746
	0 bar ... 0.1 bar		PFT-SRBX10SG1SSAAMSSZ	6038719
	G 1 B flush-mounted with O-ring		0 bar ... 1.6 bar	Flush-mounted membrane
0 bar ... 1 bar		PFT-FRB1X0SF1OSSAMSSZ	6038820	
0 bar ... 0.6 bar		PFT-FRBX60SF1OSSAMSSZ	6038819	
0 bar ... 0.4 bar		PFT-FRBX40SF1OSSAMSSZ	6048572	
0 bar ... 0.25 bar		PFT-FRBX25SF1OSSAMSSZ	6038818	
0 bar ... 0.16 bar		PFT-FRBX16SF1OSSAMSSZ	6042220	
0 bar ... 0.1 bar		PFT-FRBX10SF1OSSAMSSZ	6038817	
G ¼ A according to DIN 3852-E		0 bar ... 400 bar	Standard	
	0 bar ... 250 bar	PFT-SRB250SG1SSAVMSSZ		6038752
	0 bar ... 100 bar	PFT-SRB100SG1SSAVMSSZ		6038748
	0 bar ... 10 bar	PFT-SRB010SG1SSAVMSSZ		6038679
	0 bar ... 1 bar	PFT-SRB1X0SG1SSAVMSSZ		6038724
	0 bar ... 0.1 bar	PFT-SRBX10SG1SSAVMSSZ		6038721

D

Compound pressure

- **Electrical connection:** Round connector M12 x 1, 4-pin, IP 67
- **Process connection:** G ¼ A according to DIN 3852-E
- **Seal:** Without seal
- **Pressure port:** Standard
- **Accuracy:** ≤ ± 0.5 %

Output signal	Measuring range	Model name	Part no.
4 mA ... 20 mA	-1 bar ... 9 bar	PFT-SCB010SG1SSAAMSSZ	6038786
	-1 bar ... +1.5 bar	PFT-SCB2X5SG1SSAAMSSZ	6039522
	-1 bar ... 0 bar	PFT-SCB1X0SG1SSAAMSSZ	6038782
0 ... 10 V, 3-wire	-1 bar ... +9 bar	PFT-SCB010SG1SSAVMSSZ	6038788
	-1 bar ... 0 bar	PFT-SCB1X0SG1SSAVMSSZ	6038784
	-1 bar ... +1.5 bar	PFT-SCB2X5SG1SSAVMSSZ	6049860

Measuring ranges

	Gauge pressure	Overpressure safety
X10	0 ... 0.1 bar	2 bar
X16	0 ... 0.16 bar	1.5 bar
X25	0 ... 0.25 bar	2 bar
X40	0 ... 0.4 bar	2 bar
X60	0 ... 0.6 bar	4 bar
1X0	0 ... 1 bar	5 bar
1X6	0 ... 1.6 bar	10 bar
2X5	0 ... 2.5 bar	10 bar
4X0	0 ... 4 bar	17 bar
6X0	0 ... 6 bar	35 bar
010	0 ... 10 bar	35 bar
016	0 ... 16 bar	80 bar
025	0 ... 25 bar	50 bar
040	0 ... 40 bar	80 bar
060	0 ... 60 bar	120 bar
100	0 ... 100 bar	200 bar
160	0 ... 160 bar	320 bar
250	0 ... 250 bar	500 bar
400	0 ... 400 bar	800 bar
600	0 ... 600 bar	1,200 bar

	Absolute pressure	Overpressure safety
X25	0 ... 0.25 bar abs	2 bar abs
X40	0 ... 0.4 bar abs	2 bar abs
X60	0 ... 0.6 bar abs	4 bar abs
1X0	0 ... 1 bar abs	5 bar abs
1X6	0 ... 1.6 bar abs	10 bar abs
2X5	0 ... 2.5 bar abs	10 bar abs
4X0	0 ... 4 bar abs	17 bar abs
6X0	0 ... 6 bar abs	35 bar abs
010	0 ... 10 bar abs	35 bar abs
016	0 ... 16 bar abs	80 bar abs
025	0 ... 25 bar abs	80 bar abs
400	800 ... 1,200 bar abs	5,000 mbar abs

	Compound pressure	Overpressure safety
100	-0.1 ... 0 bar	4 bar
160	-0.16 ... 0 bar	2 bar
250	-0.25 ... 0 bar	2 bar
400	-0.4 ... 0 bar	1.5 bar
600	-0.6 ... 0 bar	1 bar
1X0	-1 ... 0 bar	5 bar
1X6	-1 ... +0.6 bar	10 bar
2X5	-1 ... +1.5 bar	10 bar
4X0	-1 ... +3 bar	17 bar
6X0	-1 ... +5 bar	35 bar
010	-1 ... +9 bar	35 bar
016	-1 ... +15 bar	80 bar
025	-1 ... +24 bar	50 bar

	Gauge pressure	Overpressure safety
5X0	0 ... 5 psi	29 psi
010	0 ... 10 psi	29 psi
015	0 ... 15 psi	72.5 psi
025	0 ... 25 psi	145 psi
030	0 ... 30 psi	145 psi
050	0 ... 50 psi	240 psi
100	0 ... 100 psi	500 psi
160	0 ... 160 psi	500 psi
200	0 ... 200 psi	1,160 psi
300	0 ... 300 psi	1,160 psi
500	0 ... 500 psi	1,160 psi
1K0	0 ... 1,000 psi	1,740 psi
1K5	0 ... 1,500 psi	2,900 psi
2K0	0 ... 2,000 psi	4,600 psi
3K0	0 ... 3,000 psi	7,200 psi
5K0	0 ... 5,000 psi	11,600 psi
8K0	0 ... 8,000 psi	17,400 psi

	Absolute pressure	Overpressure safety
015	0 ... 15 psi abs	72.5 psi abs
025	0 ... 25 psi abs	145 psi abs
050	0 ... 50 psi abs	240 psi abs
100	0 ... 100 psi abs	500 psi abs
250	0 ... 250 psi abs	1,160 psi abs

	Compound pressure	Overpressure safety
015	-14.5 ... 0 psi	72.5 psi
045	-14.5 ... +30 psi	240 psi
075	-14.5 ... +60 psi	240 psi
115	-14.5 ... +100 psi	500 psi
175	-14.5 ... +160 psi	1,160 psi
215	-14.5 ... +200 psi	1,160 psi
315	-14.5 ... +300 psi	1,160 psi

D

Dimensional drawings

dimensions in mm (inch)

Housing with circular plug-in connector M12 x 1

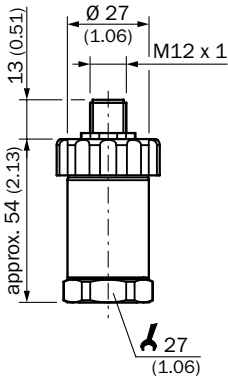

Housing with L-connector (DIN EN 175301-803 A)

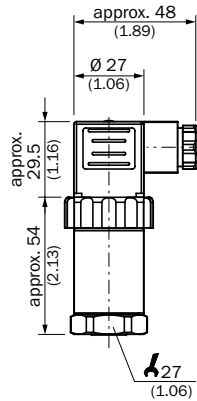

Housing with flying leads

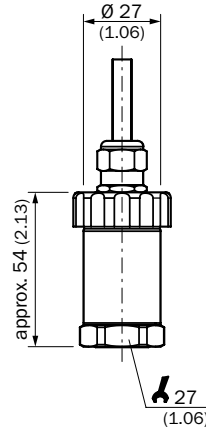

G 1/4 A DIN 3852-E

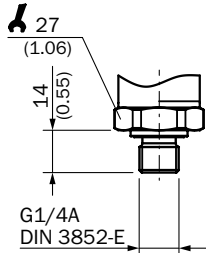

G 1/4 female

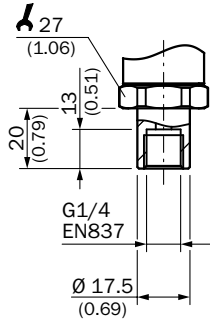

G 1/2 B according to EN 837

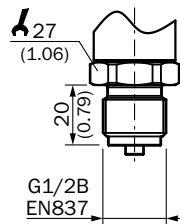

1/4" NPT

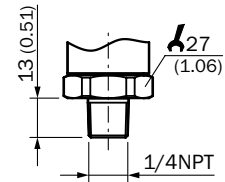

M20 x 1.5

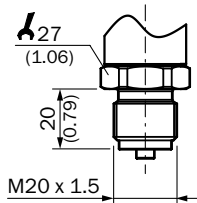

7/16" -20 UNF

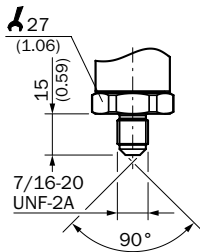

R 1/4 ISO 7

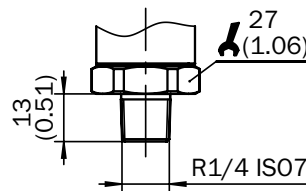

All dimensions in mm (inch)

G 1 B without cooling section

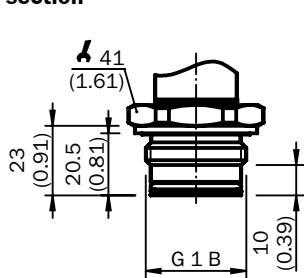

G 1 B with cooling section

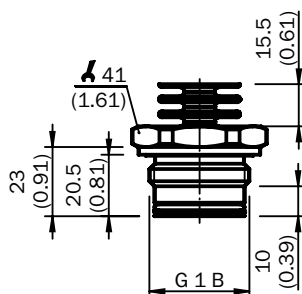

G 1/2 B without cooling section

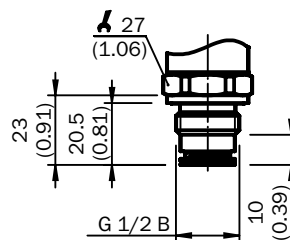

G 1/2 B with cooling section

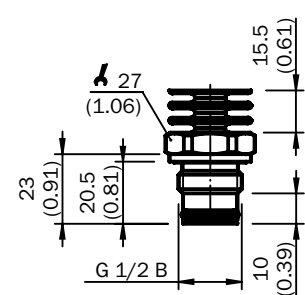



Recommended accessories

Mounting brackets/plates

	Brief description	Model name	Part no.
	Mounting bracket for simple and stable wall mounting of pressure sensors with 27 mm hexagon, material: Aluminium	BEF-FL-ALUPBS-HLDR	5322501

Flanges





	Brief description	Model name	Part no.
	Weld-in flange/weld-in socket for articles with flush-mounted membrane, process connection G 1 B, material: Stainless steel 1.4571	BEF-FL-316G10-B0PH	5322450
	Weld-in flange/weld-in socket for articles with flush-mounted membrane, process connection G 1/2 B, material: Stainless steel 1.4571	BEF-FL-316G12-B0PH	5322449

Device protection (mechanical)

	Brief description	Model name	Part no.
	Cooling element, extension of the process temperature up to 150 °C. Maximum ambient temperature 30 °C. Max. process pressure 200 bar. Not suitable for pressure measurement in steam. Outer thread G 1/2, inner thread G 1/2. Material: Stainless steel 1.4571	BEF-CE-G12G12-150C	5324393
	Cooling element, extension of the process temperature up to 200 °C. Maximum ambient temperature 30 °C. Max. process pressure 200 bar. Not suitable for pressure measurement in steam. Outer thread G 1/2, inner thread G 1/2. Material: Stainless steel 1.4571	BEF-CE-G12G12-200C	5324394

Plug connectors and cables

- **Connector type:** Cable socket
- **Connection type:** M12, 4-pin

	Enclosure rating	Sheath material	Cable outlet	Cable length	Model name	Part no.	
	IP 67	PVC	Straight	2 m	DOL-1204-G02M	6009382	
				5 m	DOL-1204-G05M	6009866	
				10 m	DOL-1204-G10M	6010543	
				15 m	DOL-1204-G15M	6010753	
				20 m	DOL-1204-G20M	6034401	
			Angled	2 m	DOL-1204-W02M	6009383	
				5 m	DOL-1204-W05M	6009867	
				10 m	DOL-1204-W10M	6010541	
				15 m	DOL-1204-W15M	6036474	
				20 m	DOL-1204-W20M	6033559	
	IP 68	PUR halogen free	Straight	2 m	DOL-1204-G02MC	6025900	
				5 m	DOL-1204-G05MC	6025901	
				10 m	DOL-1204-G10MC	6025902	
				15 m	DOL-1204-G15MC	6034749	
				20 m	DOL-1204-G20MC	6034750	
				Angled	25 m	DOL-1204-G25MC	6034751
					2 m	DOL-1204-W02MC	6025903
					5 m	DOL-1204-W05MC	6025904
					10 m	DOL-1204-W10MC	6025905
					15 m	DOL-1204-W15MC	6034752
	20 m	DOL-1204-W20MC	6034753				
	25 m	DOL-1204-W25MC	6034754				

A clean solution



Product description

With its flush-mounted stainless steel membranes and large range of hygienic process connectors, the PHT pressure transmitter is ideal for demanding hygienic applications in the food and beverage, pharmaceutical and cosmetics industries. With enhanced

process temperatures, resistance to corrosive fluids, cavity-free design with hygienically-graded process connections, the PHT is distinguished by its outstanding functionality and certifications issued by EHEDG and 3-A Sanitary Standards, Inc.

At a glance

- Robust and precise pressure measurement technology
- Flush-mounted, hermetically sealed stainless steel membrane with roughness Ra < 0.4 µm
- Wetted parts stainless steel 1.4435, housing stainless steel 1.4571
- CIP/SIP resistant
- Large range of hygienic process connectors
- Stainless steel housing with enclosure rating of up to IP 68
- Field housing available (IP 67)

Your benefits

- Perfectly suited for demanding hygienic applications in the food and beverage, pharmaceutical and cosmetics industries
- Safe hygienic operation through EHEDG and 3-A certifications
- High reliability due to robust design and use of high-grade materials
- Withstands CIP/SIP, ensuring high system availability and reliability
- Transmitter housing is easily cleaned
- Versatile configurability optimizes solutions



Additional information

- Detailed technical data.....D-145
- Ordering information.....D-146
- Type code.....D-148
- Dimensional drawings.....D-149

→ www.mysick.com/en/PHT

For more information, just enter the link or scan the QR code and get direct access to technical data, CAD design models, operating instructions, software, application examples and much more.



D

Detailed technical data

Features

Pressure units	bar, MPa, psi and kg/cm ²
Measuring ranges	
Gauge pressure	0 bar ... 0.25 bar up to 0 bar ... 25 bar
Absolute pressure	0 bar ... 0.25 bar up to 0 bar ... 16 bar
Compound pressure	-1 bar ... 0 bar up to -1 bar ... +15 bar
Process temperature	-20 °C ... +150 °C
Signal output and maximum ohmic load R_A	4 mA ... 20 mA, 2-wire (R _A ≤ (L ⁺ - 10 V) / 0.02 A [Ohm]) The variant with field housing and current output 4 mA ... 20 mA features test terminals that allow metering of the signal current without having to disconnect the device. 0 V ... 10 V, 3-wire (R _A > 10 kOhm) 0 V ... 5 V, 3-wire (R _A > 5 kOhm)
Zero and span adjustment	± 5 % using potentiometer inside the instrument

Performance

Non-linearity	≤ ± 0.2 %
Accuracy	≤ ± 0.5 % of span Optional ≤ ± 0.25 % of span (adjusted in vertical mounting position with lower pressure connection)
Non-repeatability	≤ ± 0.1 % of span
Response time (10 % ... 90 %)	≤ 10 ms
Long-term drift/one-year stability	≤ 0.2 % of span
Temperature coefficient in rated temperature range	Mean TC of zero: ≤ 0.2 % of span/ 10 K, with pressure ranges 0 bar ... 0.6 bar to 0 bar ... 25 bar ≤ 0.25 % of span/ 10 K, with pressure range 0 bar ... 0.4 bar ≤ 0.4 % of span/ 10 K with pressure range 0 bar ... 0.25 bar Mean TC of span ≤ 0.2 % of span / 10 K
Rated temperature range	0 °C ... +80 °C

Mechanics/electronics

Process connections	See type code
Wetted parts	Stainless steel 1.4435
Internal transmission fluid	Synthetic oil, FDA approved
Housing material	Stainless steel 1.4571
Electrical connection/enclosure rating ¹⁾	Round connector M12 x 1, 4-pin, IP 67 L-connector (DIN EN 175301-803 A), IP 65 Field housing IP 67 Flying leads, 1.5 m, IP 68 (zero and span not adjustable) Flying leads, 3 m, IP 68 (zero and span not adjustable)
Supply voltage	10 V DC ... 30 V DC 14 V DC ... 30 V DC with output signal 0 V ... 10 V 11 V DC ... 30 V DC with output signal 4 mA ... 20 mA and field housing
Electrical safety	Overvoltage protection: 36 V DC Short-circuit protection: Q _A towards M Reverse polarity protection: L ⁺ towards M Protection class: III

¹⁾ Enclosure rating IP per IEC 60529. The enclosure rating classes specified only apply while the pressure transmitter is connected with female connectors that provide the corresponding enclosure rating.

Dielectric strength	500 V DC NEC Class 02 power supply (low voltage and low current max. 100 VA even under fault conditions)
CE-conformity	EMC directive: 2004/108/EEC, EN 61326-2-3
Weight sensor	Approx. 500 g

¹⁾ Enclosure rating IP per IEC 60529. The enclosure rating classes specified only apply while the pressure transmitter is connected with female connectors that provide the corresponding enclosure rating.

Ambient data

Ambient temperature	-20 °C ... +80 °C
Storage temperature	-40 °C... +100 °C
Shock load	500 g according to IEC 60068-2-27 (mechanical shock)
Vibration load	15 g per IEC 60068-2-6 (vibration under resonance)

Ordering information

The part numbers below show a selection of our common configurations and represent only a portion of the product portfolio. The type code on page D-148 indicates possible configurations that can be ordered.

Gauge pressure

- **Output signal:** 4 mA ... 20 mA
- **Accuracy:** $\leq \pm 0.5$ % of span
- **Seal:** Without seal

Electrical connection	Process connection	Measuring range	Model name	Part no.
Round connector M12 x 1, 4-pin, IP 67	Varivent Connector Type F	0 bar ... 25 bar	PHT-RB025SVF0S0AMS0Z	6039346
		0 bar ... 10 bar	PHT-RB010SVF0S0AMS0Z	6039345
		0 bar ... 6 bar	PHT-RB6X0SVF0S0AMS0Z	6039344
		0 bar ... 2.5 bar	PHT-RB2X5SVF0S0AMS0Z	6039343
		0 bar ... 1 bar	PHT-RB1X0SVF0S0AMS0Z	6039342
		0 bar ... 0.25 bar	PHT-RBX25SVF0S0AMS0Z	6039340
	Tri-Clamp 1 ½"	0 bar ... 25 bar	PHT-RB025ST10S0AMS0Z	6039297
		0 bar ... 10 bar	PHT-RB010ST10S0AMS0Z	6039296
		0 bar ... 6 bar	PHT-RB6X0ST10S0AMS0Z	6039295
		0 bar ... 2.5 bar	PHT-RB2X5ST10S0AMS0Z	6039294
		0 bar ... 1 bar	PHT-RB1X0ST10S0AMS0Z	6039293
		0 bar ... 0.25 bar	PHT-RBX25ST10S0AMS0Z	6039291
	Conical coupling (DIN 11851) DN 40 with union nut	0 bar ... 25 bar	PHT-RB025S540S0AMS0Z	6039318
		0 bar ... 10 bar	PHT-RB010S540S0AMS0Z	6039317
		0 bar ... 6 bar	PHT-RB6X0S540S0AMS0Z	6039316
		0 bar ... 2.5 bar	PHT-RB2X5S540S0AMS0Z	6039315
		0 bar ... 1 bar	PHT-RB1X0S540S0AMS0Z	6039314
		0 bar ... 0.25 bar	PHT-RBX25S540S0AMS0Z	6039312

D

Electrical connection	Process connection	Measuring range	Model name	Part no.
Field housing IP 67	Varivent Connector Type F	0 bar ... 25 bar	PHT-RB025SVF0S0AFT0Z	6039458
		0 bar ... 10 bar	PHT-RB010SVF0S0AFT0Z	6039457
		0 bar ... 6 bar	PHT-RB6X0SVF0S0AFT0Z	6039456
		0 bar ... 2.5 bar	PHT-RB2X5SVF0S0AFT0Z	6039455
		0 bar ... 1 bar	PHT-RB1X0SVF0S0AFT0Z	6039454
		0 bar ... 0.25 bar	PHT-RBX25SVF0S0AFT0Z	6039452
	Tri-Clamp 1 ½"	0 bar ... 25 bar	PHT-RB025ST10S0AFT0Z	6039409
		0 bar ... 10 bar	PHT-RB010ST10S0AFT0Z	6039408
		0 bar ... 6 bar	PHT-RB6X0ST10S0AFT0Z	6039407
		0 bar ... 2.5 bar	PHT-RB2X5ST10S0AFT0Z	6039406
		0 bar ... 1 bar	PHT-RB1X0ST10S0AFT0Z	6039405
		0 bar ... 0.25 bar	PHT-RBX25ST10S0AFT0Z	6039403
	Conical coupling (DIN 11851) DN 40 with union nut	0 bar ... 25 bar	PHT-RB025S540S0AFT0Z	6039430
		0 bar ... 10 bar	PHT-RB010S540S0AFT0Z	6039429
		0 bar ... 6 bar	PHT-RB6X0S540S0AFT0Z	6039428
		0 bar ... 2.5 bar	PHT-RB2X5S540S0AFT0Z	6039427
		0 bar ... 1 bar	PHT-RB1X0S540S0AFT0Z	6039426
		0 bar ... 0.25 bar	PHT-RBX25S540S0AFT0Z	6039424

Measuring ranges

	Gauge pressure	Overpressure safety
X25	0 ... 0.25 bar	2 bar
X40	0 ... 0.4 bar	2 bar
X60	0 ... 0.6 bar	4 bar
1X0	0 ... 1 bar	5 bar
1X6	0 ... 1.6 bar	10 bar
2X5	0 ... 2.5 bar	10 bar
4X0	0 ... 4 bar	17 bar
6X0	0 ... 6 bar	35 bar
010	0 ... 10 bar	35 bar
016	0 ... 16 bar	80 bar
025	0 ... 25 bar	80 bar

	Absolute pressure	Overpressure safety
X25	0 ... 0.25 bar abs	2 bar abs
X40	0 ... 0.4 bar abs	2 bar abs
1X0	0 ... 1 bar abs	5 bar abs
1X6	0 ... 1.6 bar abs	10 bar abs
2X5	0 ... 2.5 bar abs	10 bar abs
4X0	0 ... 4 bar abs	17 bar abs
6X0	0 ... 6 bar abs	35 bar abs
010	0 ... 10 bar abs	35 bar abs
016	0 ... 16 bar abs	80 bar abs

	Compound pressure	Overpressure safety
1X0	-1 ... 0 bar	5 bar
1X6	-1 ... +0.6 bar	10 bar
4X0	-1 ... +3 bar	17 bar
6X0	-1 ... +5 bar	35 bar
010	-1 ... +9 bar	35 bar
016	-1 ... +15 bar	80 bar

	Gauge pressure	Overpressure safety
5X0	0 ... 5 psi	29 psi
010	0 ... 10 psi	29 psi
030	0 ... 30 psi	145 psi
060	0 ... 60 psi	246 psi
100	0 ... 100 psi	500 psi
160	0 ... 160 psi	500 psi
200	0 ... 200 psi	1,160 psi
300	0 ... 300 psi	1,160 psi

	Absolute pressure	Overpressure safety
015	0 ... 15 psi abs	72.5 psi abs
025	0 ... 25 psi abs	145 psi abs
050	0 ... 50 psi abs	240 psi abs
100	0 ... 100 psi abs	500 psi abs
250	0 ... 250 psi abs	1,160 psi abs

	Compound pressure	Overpressure safety
015	-14.5... 0 psi	72.5 psi

Dimensional drawings

dimensions in mm (inch)

Housing with circular connector M12 x 1, IP 67

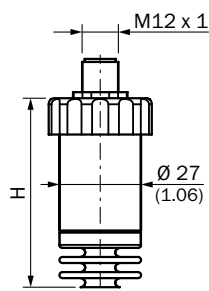

With accuracy **H**

0.5 %	64 (2.52)
0.25 %	84 (3.31)

Housing with L-connector (DIN 175301-803 A), IP 65

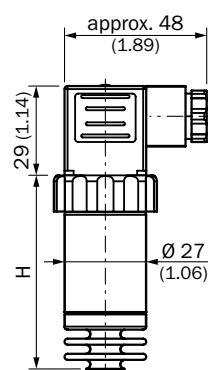

With accuracy **H**

0.5 %	64 (2.52)
0.25 %	84 (3.31)

Stainless steel field housing, ground terminals, brass nickel-coated, IP 67

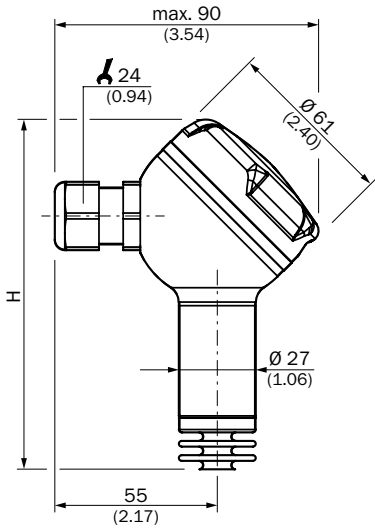

With accuracy	H
0.5 %	123 (4.84)
0.25 %	138.5 (5.45)

Conical coupling (DIN 11851) with union nut

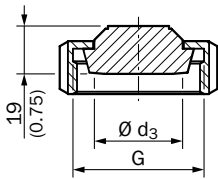

Design	G	Ø d ₃
DIN 11851 DN 25	Rd 52 x 1/6	44 (1.73)
DN 40	Rd 65 x 1/6	48 (1.89)
DN 50	Rd 78 x 1/6	61 (2.40)

DRD connector with clamping elements

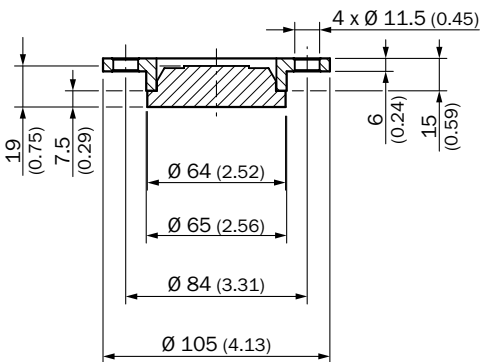

Clamp

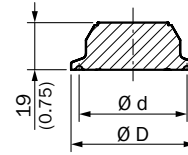

Design	Ø D	Ø d
Tri-Clamp	1 1/2"	50 (1.97) / 43.5 (1.71)
	2"	64 (2.52) / 56.6 (2.23)
DIN 32676	DN 32	50 (1.97) / 43.5 (1.71)
	DN 40	50 (1.97) / 43.5 (1.71)
	DN 50	64 (2.52) / 56.6 (2.23)
ISO 2852	DN 33.7	50 (1.97) / 43.5 (1.71)
	DN 38	50 (1.97) / 43.5 (1.71)
	DN 40	64 (2.52) / 56.6 (2.23)
	DN 51	64 (2.52) / 56.6 (2.23)

Coupling (DIN 11864-1) form A with union nut

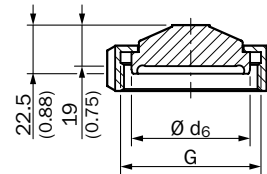

Design	G	Ø d ₆
DIN 11864-1 DN 40	Rd 65 x 1/6	54.9 (2.16)
DN 50	Rd 78 x 1/6	66.9 (2.63)

Varivent connector

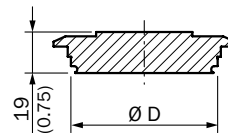

Design	Ø D
VARIVENT® Form F	50 (1.97)
Form N	68 (2.68)

D

SMS standard with union nut

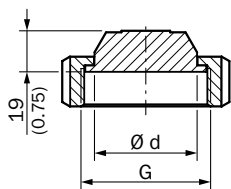

Design	G	Ø d
SMS	1 1/2" Rd 60 x 1/6	47.5 (1.87)
	2" Rd 70 x 1/6	60 (2.36)

NEUMO BioControl

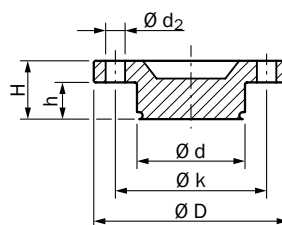

Design	Ø d	Ø d ₂	Ø D	Ø k	h	H
BioControl® Size 50	50 (1.97)	4 x 9 (0.16 x 0.35)	90 (3.54)	70 (2.76)	17 (0.67)	27 (1.06)
Size 65	68 (2.68)	4 x 11 (0.16 x 0.43)	120 (4.72)	95 (3.74)	17 (0.67)	27 (1.06)

NEUMO BioConnect flange form V

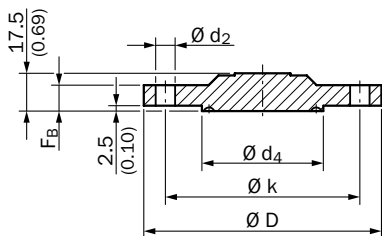

Design	Ø d ₂	Ø d ₄	Ø D	Ø k	Ø F _B
BioConnect® DN 40	4 x 9 (0.16 x 0.35)	44.2 (1.74)	100 (3.94)	80 (3.15)	10 (0.39)
DN 50	4 x 9 (0.16 x 0.35)	56.2 (2.21)	110 (4.33)	90 (3.54)	12 (0.47)

NEUMO BioConnect coupling with union nut

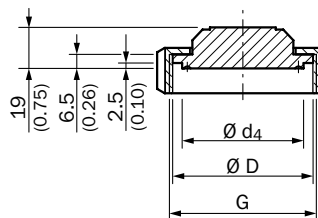

Design	G	Ø d ₄	Ø D
BioConnect® DN 40	M56 x 2	44.2 (1.74)	53 (2.09)
DN 50	M68 x 2	56.2 (2.21)	65 (2.56)

Flange (DIN 11864-2) form A

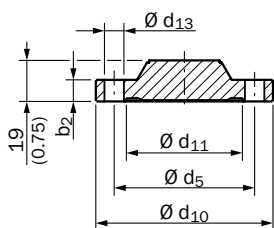

Design	Ø d ₅	Ø d ₁₀	Ø d ₁₁	Ø d ₁₃	Ø b ₂
DIN 11864-2 DN 40	65 (2.56)	82 (3.23)	53.7 (2.11)	4 x 9 (0.16 x 0.35)	10 (0.39)
DN 50	77 (3.03)	94 (3.70)	65.7 (2.59)	4 x 9 (0.16 x 0.35)	10 (0.39)

Clamp (DIN 11864-3) form A

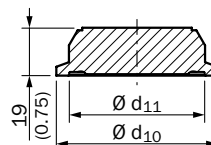

Design	Ø d ₁₀	Ø d ₁₁
DIN 11864-3 DN 40	64 (2.52)	53.7 (2.11)
DN 50	77.5 (3.05)	65.7 (2.59)



If one is not enough



Product description

The pressure transmitter PET is a solution for OEM customers for use in plant engineering and machine building. With a wide range of available measuring ranges, process connections, output signals and electrical connections, the PET is well-suited for diverse applications, such as in hydraulics, for pumps and compressors, etc. Its compact dimensions enable integration in narrow spaces.

During the development of the PET, durability and a high level of product quality were of paramount importance. As such, the PET has a circularly welded stainless steel membrane and as a result, is well-suited for a large variety of fluids. The manufacturing capabilities are set up for large quantities and provide an optimized cost-value ratio also for individual solutions.

At a glance

- Measuring ranges from 0 bar ... 6 bar up to 0 bar ... 600 bar
- Various output signals and electrical connections available
- Common process connections available
- High overpressure safety. Pressure peak protection available upon request for selected process connections.
- Circularly welded, hermetically sealed stainless steel membrane
- Stainless steel housing with enclosure rating up to IP 67 (with round connector M12 x 1)

Your benefits

- A wide range of variants enables a perfect match to individual requirements
- Space-saving due to its compact size
- Time-saving due to quick and simple installation
- Manufacturing capabilities that are aligned to OEM demands ensure an excellent price-performance ratio for application-specific solutions
- Wetted parts are made from stainless steel for universal use even with a large variety of corrosive fluids



Additional information

- Detailed technical dataD-153
- Ordering informationD-155
- Type codeD-156
- Dimensional drawingsD-157
- Recommended accessoriesD-160

→ www.mysick.com/en/PET

For more information, just enter the link or scan the QR code and get direct access to technical data, CAD design models, operating instructions, software, application examples and much more.



D

Detailed technical data

Features

Measuring ranges		
	Gauge pressure	min. 0 bar ... 6 bar up to max. 0 bar ... 600 bar min. 0 psi ... 160 psi up to max. 0 psi ... 8,000 psi
	Compound pressures	min. -1 bar ... 5 bar up to max. -1 bar ... 59 bar min. -30 inHg ... 100 psi up to max. -30 inHg ... 300 psi
Overload protection		2-fold (3-fold upon request)
Process temperature		-30 °C ... +100 °C
Output signals		
	Current output signal	4 mA ... 20 mA, 2-wire
	Voltage output signal	0 V ... 10 V, 3-wire 0 V ... 5 V, 3-wire 1 V ... 5 V, 3-wire 0.5 V ... 4.5 V, 3-wire
	Ratiometric output signal	0.5 V ... 4.5 V, 3-wire

Performance

Non-linearity	$\leq \pm 0.5$ % of span (best fit straight line, BFSL) $\leq \pm 0.6$ % of span (best fit straight line, BFSL) for measurement ranges 0 bar ... 6 bar, 0 bar ... 10 bar, -1 bar ... 5 bar, -1 bar ... +9 bar and 0 psi ... 100 psi
Accuracy	$\leq \pm 1.2$ % of span (at room temperature)
Response time	< 2 ms
Measurement deviation of zero signal	$\leq \pm 0.5$ % of span $\leq \pm 0.7$ % of span for measurement ranges 0 bar ... 6 bar, 0 bar ... 10 bar, -1 bar ... 5 bar, -1 bar ... +9 bar and 0 psi ... 100 psi
Temperature error	$\leq \pm 1.5$ % of span
Long-term drift/one-year stability	$\leq \pm 0.3$ % of span (per year)
Rated temperature range	0 °C ... +80 °C
Reference conditions	According to IEC 61298-1

Mechanics/electronics

Process connection	See type code
Seal	NBR ¹⁾ FPM/FKM ²⁾ Without seal
Wetted parts	Stainless steel 316L, stainless steel 13-8 PH
Pressure port	3.5 mm Standard
Pressure peak dampening ³⁾	Through optional integrated pressure port 0.6 mm or 0.3 mm
Housing material	Stainless steel 316L, PBT GF30
Enclosure rating ⁴⁾	IP 67, for round connector (according to IEC 60529) IP 65, for angle plug (acc. IEC 60529)
Electrical connection	Round connector M12 x 1, 4-pin For L-connector according to DIN EN 175301-803 A (no mating connector)

¹⁾ Only for process connection G ¼ A according to DIN 3852-E.

²⁾ Only for process connections G ¼ A according to DIN 3852-E, 7/16"-20 UNF and 9/16"-18 UNF.

³⁾ Available upon request for process connections G ¼ A according to DIN 3852-E, ¼" NPT, R ¼ according to ISO 7 and 7/16"-20 UNF.

⁴⁾ Enclosure rating IP per IEC 60529. The enclosure rating classes specified only apply while the pressure transmitter is connected with female connectors that provide the corresponding enclosure rating.

⁵⁾ Electrical circuit in accordance with section 9.3 of UL/EN/IEC 61010-1 or an LPS to UL/EN/ IEC 60950-1 or class 2 in accordance with UL1310/UL1585 (NEC or CEC). The power supply must be suitable for operation above 2,000 m should the pressure transmitter be used at this altitude.

Supply voltage ⁵⁾	4 mA ... 20 mA, 2-wire 0 V ... 10 V, 3-wire 0 V ... 5 V, 3-wire 1 V ... 5 V, 3-wire 0.5 V ... 4.5 V, 3-wire 0.5 V ... 4.5 V, ratiometric, 3-wire	8 V DC ... 30 V DC 14 V DC ... 30 V DC 8 V DC ... 30 V DC 8 V DC ... 30 V DC 8 V DC ... 30 V DC 5 V DC ± 10 %
Maximum ohmic load R _A		≤ (L ⁺ - 7 V) / 0.02 A [Ohm] with current output signal > Q _{A, max} / 1 mA [Ohm] with voltage output signal > 4.5 kΩ for ratiometric output signal
Maximum power consumption	Current output signal Voltage output signal Ratiometric output signal	25 mA (signal current, maximum 25 mA) 5 mA 5 mA
Initialization time		15 ms
Protection class		III
Isolation voltage		750 V DC
Overvoltage protection		36 V DC
Short-circuit protection		Output Q _A towards M
Reverse polarity protection		L ⁺ towards M
CE-conformity		2004/108/EC, EN 61326-1 emission (group 1, class B) and interference immunity (industrial application) and pressure equipment directive 97/23/EC
RoHS certificate		✓
Service life		Minimum 10 mill. load cycles

¹⁾ Only for process connection G ¼ A according to DIN 3852-E.

²⁾ Only for process connections G ¼ A according to DIN 3852-E, 7/16"-20 UNF and 9/16"-18 UNF.

³⁾ Available upon request for process connections G ¼ A according to DIN 3852-E, ¼" NPT, R ¼ according to ISO 7 and 7/16"-20 UNF.

⁴⁾ Enclosure rating IP per IEC 60529. The enclosure rating classes specified only apply while the pressure transmitter is connected with female connectors that provide the corresponding enclosure rating.

⁵⁾ Electrical circuit in accordance with section 9.3 of UL/EN/IEC 61010-1 or an LPS to UL/EN/ IEC 60950-1 or class 2 in accordance with UL1310/UL1585 (NEC or CEC). The power supply must be suitable for operation above 2,000 m should the pressure transmitter be used at this altitude.

Ambient data

Ambient temperature operation	-30 °C ... +100 °C
Storage temperature	-30 °C ... +100 °C
Shock load	40 g (6 ms) according to IEC 60068-2-27 (mechanical shock)
Vibration load	20 g (20 Hz ... 2,000 Hz, 120 min) according to IEC 60068-2-6 (vibration at resonance)



Ordering information

The part numbers below show a selection of our common configurations and represent only a portion of the product portfolio. The type code on page D-156 indicates all possible configurations that can be ordered.

Delivery: Packaging with 50 pieces.

Gauge pressure

- **Electrical connection:** Round connector M12 x 1, 4-pin
- **Pressure port:** Standard

Output signal	Process connection	Seal	Measuring range	Model name	Part no.
4 mA ... 20 mA, 2-wire	G ¼ A, G ¼ A according to DIN 3852-E	NBR	0 bar ... 600 bar	PET-1RB600G1NSAMA	6049224
			0 bar ... 400 bar	PET-1RB400G1NSAMA	6049223
			0 bar ... 250 bar	PET-1RB250G1NSAMA	6049222
			0 bar ... 100 bar	PET-1RB100G1NSAMA	6048928
			0 bar ... 10 bar	PET-1RB010G1NSAMA	6049221
	1¼" NPT	Without seal	0 bar ... 600 bar	PET-1RB600N10SAMA	6049236
			0 bar ... 400 bar	PET-1RB400N10SAMA	6049235
			0 bar ... 250 bar	PET-1RB250N10SAMA	6049234
			0 bar ... 100 bar	PET-1RB100N10SAMA	6049233
			0 bar ... 10 bar	PET-1RB010N10SAMA	6049232
0 V ... 10 V, 3-wire	G ¼ A according to DIN 3852-E	NBR	0 bar ... 600 bar	PET-1RB600G1NSVMC	6049230
			0 bar ... 400 bar	PET-1RB400G1NSVMC	6049229
			0 bar ... 250 bar	PET-1RB250G1NSVMC	6049228
			0 bar ... 100 bar	PET-1RB100G1NSVMC	6049227
			0 bar ... 10 bar	PET-1RB010G1NSVMC	6049226
	1¼" NPT	Without seal	0 bar ... 600 bar	PET-1RB600N10SVMC	6049242
			0 bar ... 400 bar	PET-1RB400N10SVMC	6049241
			0 bar ... 250 bar	PET-1RB250N10SVMC	6049240
			0 bar ... 100 bar	PET-1RB100N10SVMC	6049239
			0 bar ... 10 bar	PET-1RB010N10SVMC	6049238

Compound pressures

- **Electrical connection:** Round connector M12 x 1, 4-pin
- **Measuring range:** -1 bar 9 bar
- **Pressure port:** Standard

Output signal	Process connection	Seal	Model name	Part no.
4 mA ... 20 mA, 2-wire	G ¼ A, G ¼ A according to DIN 3852-E	NBR	PET-1CB010G1NSAMA	6049220
	1¼" NPT	Without seal	PET-1CB010N10SAMA	6049231
0 V ... 10 V, 3-wire	G ¼ A, G ¼ A according to DIN 3852-E	NBR	PET-1CB010G1NSVMC	6049225
	1¼" NPT	Without seal	PET-1CB010N10SVMC	6049237

Type code

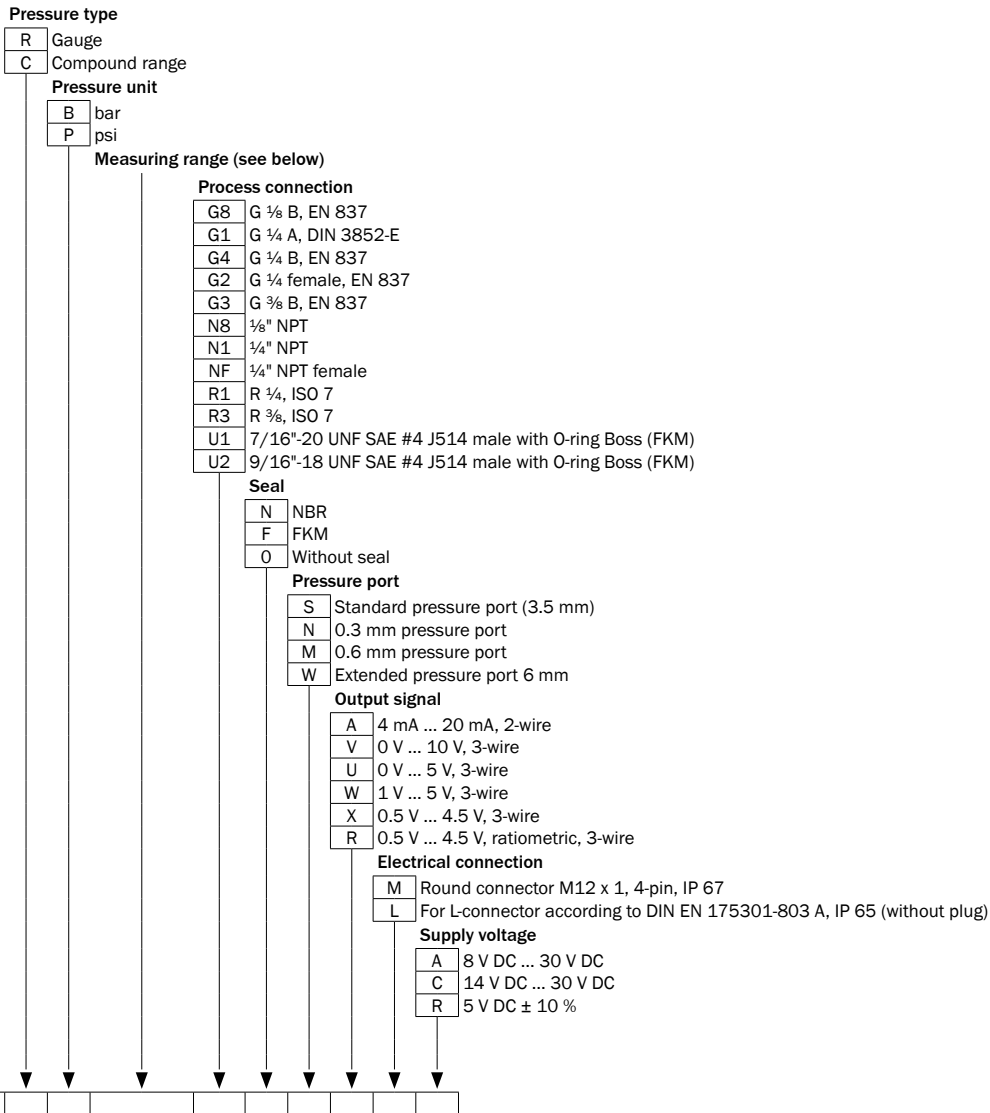

D

Not all variations of the type code can be combined! Not all available variations are shown.

Measuring range

	Gauge pressure
6X0	0 bar ... 6 bar
010	0 bar ... 10 bar
016	0 bar ... 16 bar
025	0 bar ... 25 bar
040	0 bar ... 40 bar
060	0 bar ... 60 bar
100	0 bar ... 100 bar
160	0 bar ... 160 bar
250	0 bar ... 250 bar
400	0 bar ... 400 bar
600	0 bar ... 600 bar

	Compound pressure
6X0	-1 bar ... +5 bar
010	-1 bar ... +9 bar
016	-1 bar ... +15 bar
025	-1 bar ... +24 bar
040	-1 bar ... +39 bar
060	-1 bar ... +59 bar

	Gauge pressure
100	0 psi ... 100 psi
160	0 psi ... 160 psi
200	0 psi ... 200 psi
250	0 psi ... 250 psi
300	0 psi ... 300 psi
400	0 psi ... 400 psi
500	0 psi ... 500 psi
600	0 psi ... 600 psi
750	0 psi ... 750 psi
800	0 psi ... 800 psi
1K0	0 psi ... 1,000 psi
1K5	0 psi ... 1,500 psi
2K0	0 psi ... 2,000 psi
3K0	0 psi ... 3,000 psi
4K0	0 psi ... 4,000 psi
5K0	0 psi ... 5,000 psi
6K0	0 psi ... 6,000 psi
7K5	0 psi ... 7,500 psi
8K0	0 psi ... 8,000 psi

	Compound pressure
115	-14.5 ... +100 psi
175	-14.5 ... +160 psi
215	-14.5 ... +200 psi
315	-14.5 ... +300 psi

Dimensional drawings

dimensions in mm (inch)

Process connection G 1/4 B according to EN 837 with round connector M12 x 1, 4-pin

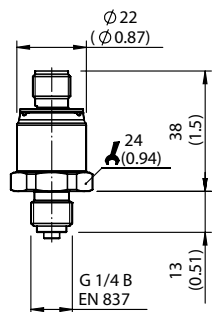

Process connection G 1/8 B according to EN 837 with connection for L-connector according to DIN EN 175301-803 A

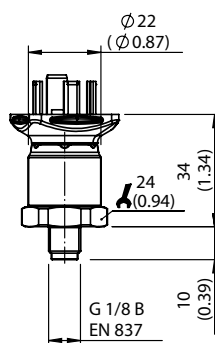

Process connection G 1/4 A according to DIN 3852-E with round connector M12 x 1, 4-pin

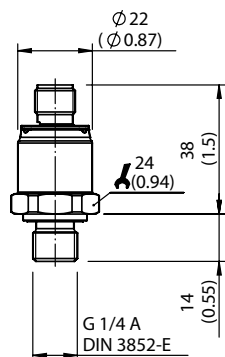

Process connection G 1/4 A according to DIN 3852-E with connection for L-connector according to DIN EN 175301-803 A

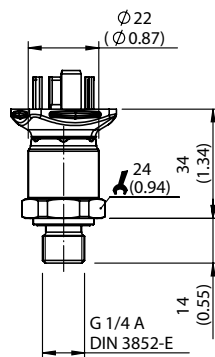

D

Process connection G 1/8 B according to EN 837 with round connector M12 x 1, 4-pin

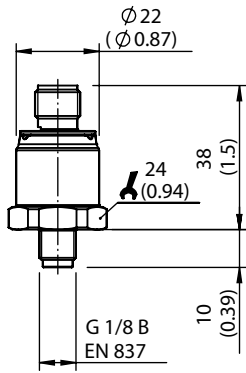

Process connection G 1/4 B according to EN 837 with connection for L-connector according to DIN EN 175301-803 A

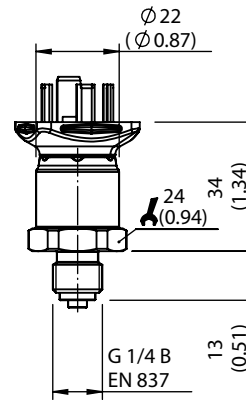

Process connection G 1/4 female according to EN 837 with round connector M12 x 1, 4-pin

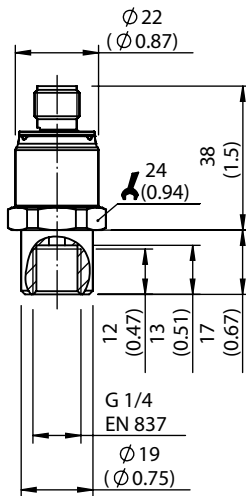

Process connection G 1/4 female according to EN 837 with connection for L-connector according to DIN EN 175301-803 A

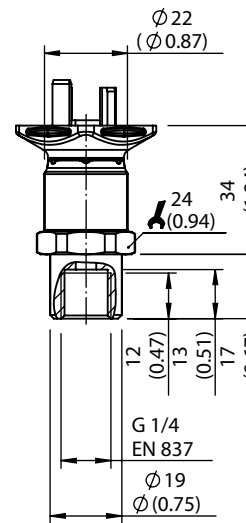

D

Process connection 1/4" NPT female with round connector M12 x 1, 4-pin

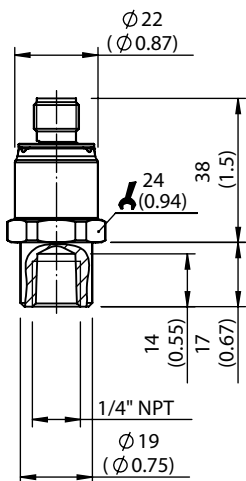

Process connection 1/4" NPT female with connection for L-connector according to DIN EN 175301-803 A

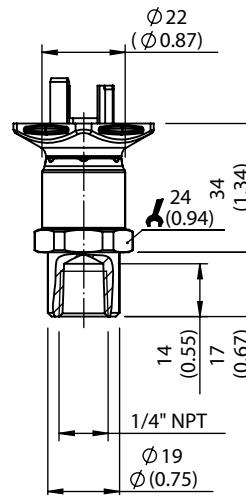

Process connection 1/4" NPT with round connector M12 x 1, 4-pin

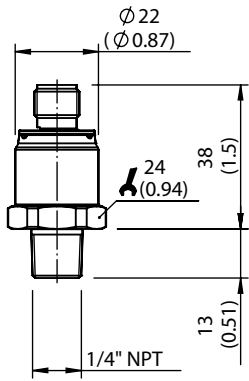

Process connection 1/4" NPT with connection for L-connector according to DIN EN 175301-803 A

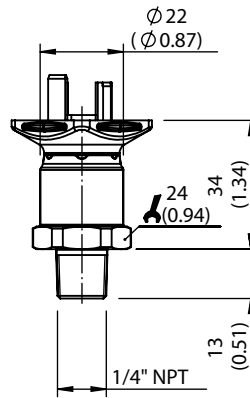

Process connection 9/16"-18 UNF SAE #4 J514 male with O-ring Boss (FKM) with round connector M12 x 1, 4-pin

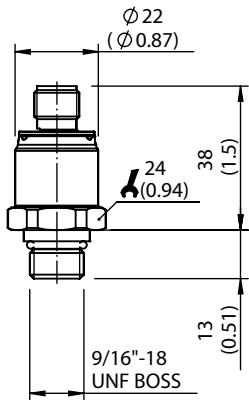



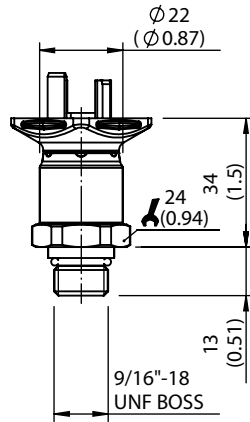

Process connection 9/16"-18 UNF SAE #4 J514 male with O-ring Boss (FKM) with connection for L-connector according to DIN EN 175301-803 A



Recommended accessories

Plug connectors and cables

- Connector type: Cable socket
- Connection type: M12, 4-pin

	Enclosure rating	Sheath material	Cable outlet	Cable length	Model name	Part no.
	IP 67	PVC	Straight	2 m	DOL-1204-G02M	6009382
				5 m	DOL-1204-G05M	6009866
				10 m	DOL-1204-G10M	6010543
				15 m	DOL-1204-G15M	6010753
				20 m	DOL-1204-G20M	6034401
			Angled	2 m	DOL-1204-W02M	6009383
				5 m	DOL-1204-W05M	6009867
				10 m	DOL-1204-W10M	6010541
				15 m	DOL-1204-W15M	6036474
				20 m	DOL-1204-W20M	6033559
	IP 68	PUR halogen free	Straight	2 m	DOL-1204-G02MC	6025900
				5 m	DOL-1204-G05MC	6025901
				10 m	DOL-1204-G10MC	6025902
				15 m	DOL-1204-G15MC	6034749
				20 m	DOL-1204-G20MC	6034750
			Angled	25 m	DOL-1204-G25MC	6034751
				2 m	DOL-1204-W02MC	6025903
				5 m	DOL-1204-W05MC	6025904
				10 m	DOL-1204-W10MC	6025905
				15 m	DOL-1204-W15MC	6034752
				20 m	DOL-1204-W20MC	6034753
				25 m	DOL-1204-W25MC	6034754







Universal temperature measurement for liquids and gases

With its product portfolio of screw-in and insertion thermometers as well as temperature switches, SICK offers high-quality solutions for contact temperature measurement in liquids and gases. The devices can optimally be adapted to meet individual requirements due to their various insertion lengths and the flexible mechanical configuration possibilities.







Your benefits

- Cost-efficiency and universal use due to its versatile and standardized configuration possibilities
- Reliable and long-term stable
- High measurement accuracy and linearity

E



Temperature sensors

General information		E-164
Product family overview		E-169
	TBS. Temperature monitoring made easy	E-170
	TBT. Well-proven temperature measurement	E-178
	TCT. Compact, rugged, precise	E-186
	TSP. Efficient and space-saving temperature measurement	E-194
	THTS. Simple, hygienic temperature measurement	E-200
	THTE. Hygienic and flexible: Temperature sensor with protection tube	E-208
	THTL. Perfect fit: Hygienic temperature measurement in pipes	E-214



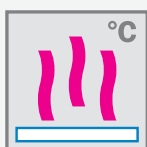

Universal temperature measurement

Whether monitoring operating conditions or controlling sensitive processes, the reliable and accurate measurement of the temperature is of vital importance in many industry segments.

With a variable product portfolio of insertion thermometers, SICK offers high-grade solutions for contact temperature measurement in liquids as well as in gases. The SICK temperature sensors use platinum elements for accurate temperature measurement across the entire temperature range. The Pt100 and Pt1000 elements comply with the accuracy classes A and B according to IEC 60751. They are located at the tip of the measuring probe.

The platinum elements are characterized by their long-term stability, high measurement accuracy and linearity. The correlation between the resistance of the Pt100/Pt1000 element and the temperature is given by the standard IEC 60751. A Pt100 element has a nominal resistance of 100 Ω at a temperature of 0 °C.

Besides the direct electrical connection to the platinum element, there are high-grade transmitters available with a standardized 4 mA ... 20 mA output signal that is proportional to the applied temperature (2-wire). The 4 mA ... 20 mA output signal allows interference-free signal transmission even across larger distances.

E

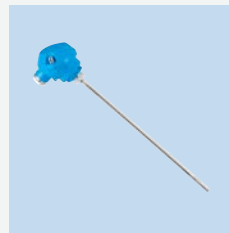

To meet the diverse installation conditions, the insertion thermometers are available with various insertion lengths as well as different threaded process connections, compression fittings and thermowells. Hence, the devices are suited for temperature measurement in pressurized vessels, too. When using a thermowell, the thermometer can be replaced without draining the equipment.

All wetted parts are made of high-grade stainless steel that has a high resistance to a wide range of corrosive media. The housings are made of stainless steel or die-cast aluminum and have an enclosure rating of up to IP 69. Thus, they are well-suited for harsh industrial environments. Due to their wide range of available configurations, the devices can be optimized for individual requirements.



E

Temperature under control – SICK thermometers in diverse applications

Temperature sensors in the machine tool industry



Temperature control of cooling lubricants with TSP

Temperature sensors are employed in many areas. One example is the machine tool industry. Reliability and long-term stability of the thermometers is mandatory for reliable machine operation. To guarantee high quality machining of the work piece, the cooling lubricant is temperature-controlled. The SICK screw-in thermometer TSP is well-suited to measure the temperature of the cooling lubricant.

Benefits:

- Reliable
- Small dimensions
- Simple installation
- Cost-saving

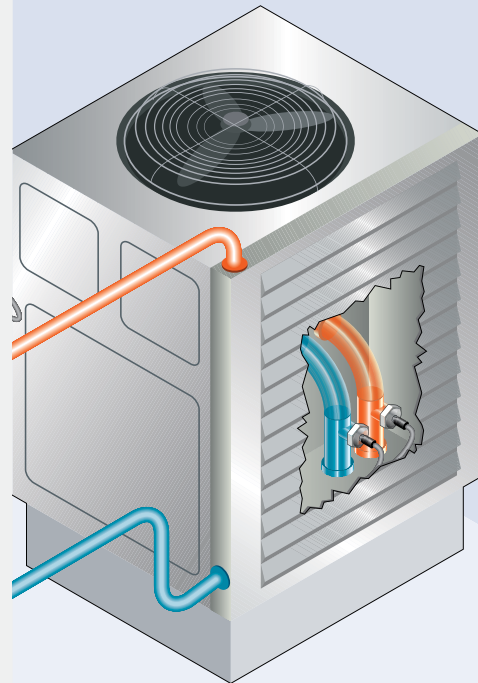

Temperature measurement in liquids

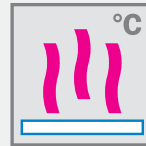
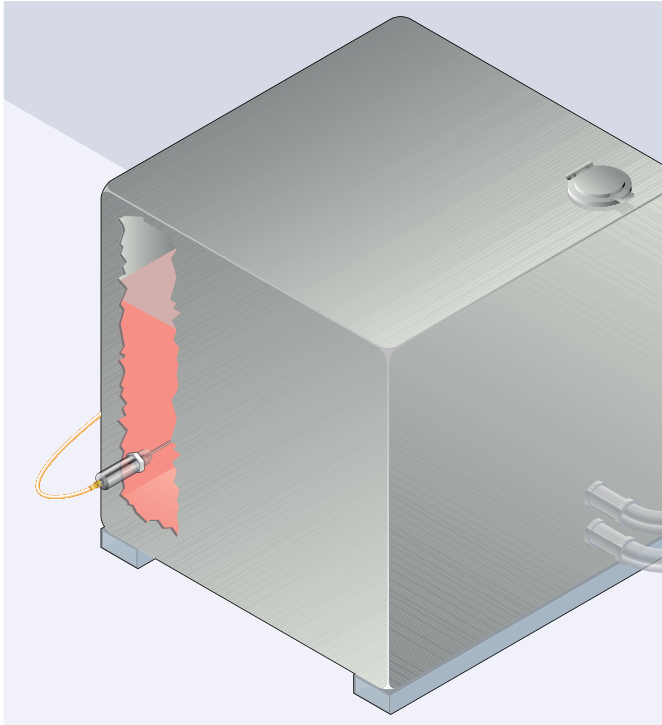



Temperature monitoring in storage tanks with TBT and TCT

Whether cooling water or hydraulic fluids – the SICK resistance thermometers are used to monitor or control temperatures in liquids. The SICK resistance thermometers of the TBT and TCT series are ideally suited for monitoring the temperature of liquids in storage tanks.

Benefits:

- Universal use
- Reliable and long-term stable
- High resistance due to stainless steel probes and thermowells
- Various fitting configurations

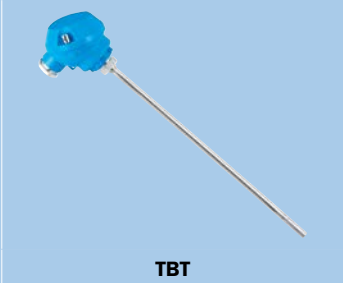

Product family overview

				
	TBS	TBT	TCT	
	Temperature monitoring made easy	Well-proven temperature measurement	Compact, rugged, precise	

Technical data overview				
Measuring range	-20 °C ... +80 °C	-50 °C ... +150 °C -50 °C ... +250 °C	-50 °C ... +150 °C -50 °C ... +250 °C	
Sensor element	Pt1000	Pt100	Pt100	
Accuracy of sensor element	Class A according IEC 60751	Class A according IEC 60751	Class A according IEC 60751	
Accuracy of optional transmitter	≤ ± 0.5 % of span	≤ ± 0.1 % of span	≤ ± 0.2 % of span	
Accuracy of switching outputs	≤ ± 0.8 % of span	-	-	
Output signal	Switching outputs PNP or NPN and optional analog output	Pt100, 4-wire, 4 mA ... 20 mA, 2-wire	Pt100, 4-wire, 4 mA ... 20 mA, 2-wire	
Electrical connection	Round connector M12 x 1	Cable gland M16 x 1.5	Round connector M12 x 1, 4-pin, L-connector (DIN EN 175301-803 A)	

At a glance				
	<ul style="list-style-type: none"> • Large display • Individually programmable transistor outputs PNP or NPN, optional analog output 4 mA ... 20 mA or 0 V ... 10 V • Round connector M12 x 1 • Measuring range -20 °C ... +80 °C • Pt1000 element, accuracy class A (IEC 60751) • Various insertion lengths and connection threads • Wetted parts made from corrosion-resistant stainless steel 1.4571 • Enclosure rating IP 65 and IP 67 	<ul style="list-style-type: none"> • Pt100 element, accuracy class A according IEC 60751 • Measuring ranges -50 °C ... +150 °C and -50 °C ... +250 °C • Wetted parts made from corrosion resistant stainless steel 1.4571 • Various mechanical adaptations and insertion lengths • Pt100 (4-wire) or 4 mA ... 20 mA (2-wire) • Cable gland M16 x 1.5 	<ul style="list-style-type: none"> • Pt100 element, accuracy class A according IEC 60751 • Measuring ranges -50 °C ... +150 °C and -50 °C ... +250 °C • Wetted parts made from corrosion resistant stainless steel 1.4571 • Various mechanical adaptations and insertion lengths, also available with thermowell • Pt100 (4-wire) or 4 mA ... 20 mA (2-wire) • Circular connector M12 x 1 (IP 67) or L-connector according to DIN EN 175301-803 A (IP 65) 	
Detailed information	→ E-170	→ E-178	→ E-186	

E

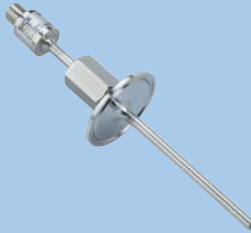
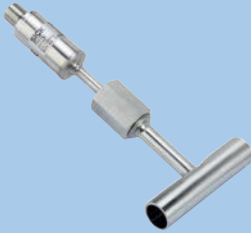
 <p>TSP</p>	 <p>THTS</p>	 <p>THTE</p>	 <p>THTL</p>
<p>Efficient and space-saving temperature measurement</p>	<p>Simple, hygienic temperature measurement</p>	<p>Hygienic and flexible: Temperature sensor with protection tube</p>	<p>Perfect fit: Hygienic temperature measurement in pipes</p>
<p>-30 °C ... +130 °C</p>	<p>-50 °C ... +150 °C -50 °C ... +250 °C</p>	<p>-50 °C ... +150 °C -50 °C ... +250 °C</p>	<p>-50 °C ... +150 °C -50 °C ... +250 °C</p>
<p>Pt100 or Pt1000</p>	<p>Pt100</p>	<p>Pt100</p>	<p>Pt100</p>
<p>Class B according to IEC 60751</p>	<p>Class A according IEC 60751</p>	<p>Class A according IEC 60751</p>	<p>Class A according IEC 60751</p>
<p>-</p>	<p>≤ ± 0.2 % of span</p>	<p>≤ ± 0.2 % of span</p>	<p>≤ ± 0.2 % of span</p>
<p>-</p>	<p>-</p>	<p>-</p>	<p>-</p>
<p>Pt100, 2-wire, Pt100, 3-wire, Pt1000, 2-wire, Pt1000, 3-wire</p>	<p>Pt100, 4-wire, 4 mA ... 20 mA, 2-wire</p>	<p>Pt100, 4-wire, 4 mA ... 20 mA, 2-wire</p>	<p>Pt100, 4-wire, 4 mA ... 20 mA, 2-wire</p>
<p>Round connector M12 x 1</p>	<p>Round connector M12 x 1</p>	<p>Round connector M12 x 1</p>	<p>Round connector M12 x 1</p>
<ul style="list-style-type: none"> Platinum element (Pt100 or Pt1000, 2-wire or 3-wire), accuracy class B according to IEC 60751 Measuring range -30 °C ... +130 °C Various connection threads and insertion lengths Wetted parts made from stainless steel 1.4305 Circular connector M12 x 1 (IP 67) 	<ul style="list-style-type: none"> Pt100 element, accuracy class A (IEC 60751) Measuring ranges -50 °C ... +150 °C and -50 °C ... +250 °C Wetted parts: Corrosion-resistant stainless steel 316L/1.4435, Ra ≤ 0.8 µm Various hygienic process connections and insertion lengths Pt100 (4-wire) or 4 mA ... 20 mA (2-wire) Round connector M12 x 1 	<ul style="list-style-type: none"> Pt100, accuracy class A (IEC 60751) Measuring ranges -50 °C ... +150 °C and -50 °C ... +250 °C Sensor probe spring-loaded in thermowell Wetted parts: Corrosion-resistant stainless steel 316L/1.4435, Ra ≤ 0.8 µm Hygienic process connections Pt100 (4-wire) or 4 mA ... 20 mA (2-wire) Round connector M12 x 1 	<ul style="list-style-type: none"> Pt100, accuracy class A (IEC 60751) Measuring ranges -50 °C ... +150 °C and -50 °C ... +250 °C In-line housing for orbital welding in pipe Sensor probe spring-loaded in thermowell Wetted parts: Corrosion-resistant Stainless steel 316L/1.4435, Ra ≤ 0.8 µm Pt100 (4-wire) or 4 mA ... 20 mA (2-wire) Round connector M12 x 1
<p>→ E-194</p>	<p>→ E-200</p>	<p>→ E-208</p>	<p>→ E-214</p>



Temperature monitoring made easy



Product description

The TBS temperature switch is easy to use and has a rugged design. It is designed for temperature measurement and monitoring of operating liquids, such as hydraulic oils, coolant lubricants and cleaning liquids in machine building and manufacturing. With up to two binary outputs and one analog output, it can be used in many applications. A large, well legible display and three pushbuttons facilitate setup. The intuitive menu navigation and display use familiar and standardized features

and programming. The switching state of the binary outputs is displayed by highly visible LEDs. During installation, the TBS is uniquely flexible due to its two rotation locations. It is possible to rotate the display and the process connection independently of the sensor body, ensuring both clean cable layout and that the display is facing the user. Temperature measurement is done using a Pt1000 element that is located in the tip of the stainless steel probe.

At a glance

- Large display
- Individually programmable transistor outputs PNP or NPN, optional analog output 4 mA ... 20 mA or 0 V ... 10 V
- Round connector M12 x 1
- Measuring ranges -20 °C ... $+80\text{ °C}$
- Pt1000 element, accuracy class A (IEC 60751)
- Various insertion lengths and connection threads
- Wetted parts made from corrosion-resistant stainless steel 1.4571
- Enclosure rating IP 65 and IP 67

Your benefits

- Quick and safe set-up through superior ease of use
- Compact dimensions and rotatable housing facilitate integration
- Very reliable: splash-proof housing, high-grade materials, rugged design, and field-proven technology
- Very good long-term stability, accuracy and linearity
- Quick response time
- Versatile configuration allows for optimal solutions for specific requirements



Additional information

Detailed technical data.	E-171
Ordering information.	E-173
Type code.	E-174
Dimensional drawings	E-175
Recommended accessories.	E-176

→ www.mysick.com/en/TBS

For more information, just enter the link or scan the QR code and get direct access to technical data, CAD design models, operating instructions, software, application examples and much more.



Detailed technical data

Features

Measuring range	-20 °C ... +80 °C
Sensor element	Pt1000, 2-wire, class A according IEC 60751
Output signals	2 x PNP 1 x PNP + 4 mA ... 20 mA 2 x PNP + 4 mA ... 20 mA 1 x PNP + 0 V ... 10 V 2 x PNP + 0 V ... 10 V 2 x NPN 1 x NPN + 4 mA ... 20 mA 1 x NPN + 0 V ... 10 V 2 x NPN + 4 mA ... 20 mA 2 x NPN + 0 V ... 10 V
Switching output	
Type	Transistor switching output PNP or NPN
Number	1 or 2
Function	Normally open/normally closed, windows- and hysteresis function freely adjustable
Switching voltage	Supply voltage L ⁺ - 1 V [V DC]
Maximum switching current	≤ 250 mA
Switching delay	0 s ... 50 s, programmable, individually adjustable via control buttons
Setting accuracy of switching outputs	+ 0.1 °C
Temperature offset	± 3 °C, adjustable
Scaling of measuring range	Zero: max. +25 % of span, Full scale: max. -25 % of span
Display	14-segment LED, blue, 4-digits, height 9 mm, display electronically turnable by 180°, update: 200 ms
Rotatable housing	Display against housing with electrical connection: 330° Housing against process connection: 320°

Performance

Accuracy of sensor element ¹⁾	≤ ± (0.15 °C + 0.002 t)
Accuracy of switching output	≤ ± 0.8 % of span
Display accuracy	≤ ± 0.8 % of span ± 1 digit
Accuracy of analog output	≤ ± 0.5 % of span
Response time t₅₀ ²⁾	≤ 5 s
Response time t₉₀ ²⁾	≤ 10 s

¹⁾ |t| is the absolute value of the temperature in °C.

²⁾ Depending on sensor configuration, according to IEC 60751.

Mechanics/electronics

Process connection	See type code								
Insertion length/diameter of probe	25 mm / 6 mm 50 mm / 6 mm 100 mm / 6 mm 150 mm / 6 mm 250 mm / 6 mm 350 mm / 6 mm								
Seal	NBR FPM/FKM Without seal								
Wetted parts	Stainless steel 1.4571 (AISI 316Ti)								
Maximum process pressure ¹⁾	≤ 150 bar								
Housing material	Lower body: Stainless steel 1.4301 (AISI 304) Plastic head: PC + ABS Input keypad: TPE-E Display window: PC								
Enclosure rating ²⁾	IP 65 and IP 67 (according to IEC 60529)								
Electrical connection	Round connector M12 x 1, 4-pin Round connector M12 x 1, 5-pin (only for variants with two switching outputs and one analog output)								
Maximum ohmic load R_A	≤ 100 kΩ (switching outputs) < 0.5 kΩ (output signal 4 mA ... 20 mA) > 10 kΩ (output signal 0 V ... 10 V)								
Supply voltage	15 V DC ... 35 V DC								
Maximum current consumption	45 mA (for configurations without analog signal output) 70 mA (for configurations with analog signal output)								
Total current consumption	Max. 320 mA / 570 mA (incl. switching current)								
Electrical safety	<table border="0"> <tr> <td>Protection class</td> <td>III</td> </tr> <tr> <td>Isolation voltage</td> <td>500 V DC</td> </tr> <tr> <td>Overvoltage protection</td> <td>40 V DC</td> </tr> <tr> <td>Short-circuit protection</td> <td>Outputs Q_A, Q₁, Q₂ towards M L⁺ towards M</td> </tr> </table>	Protection class	III	Isolation voltage	500 V DC	Overvoltage protection	40 V DC	Short-circuit protection	Outputs Q _A , Q ₁ , Q ₂ towards M L ⁺ towards M
Protection class	III								
Isolation voltage	500 V DC								
Overvoltage protection	40 V DC								
Short-circuit protection	Outputs Q _A , Q ₁ , Q ₂ towards M L ⁺ towards M								
CE-conformity	2004/108/EC, EN 61326-1 emission (group 1, class B) and interference immunity (industrial application)								
RoHS certificate	✓								

¹⁾ At room temperature and when connected by thread.

²⁾ The enclosure rating classes specified only apply while the thermometer is connected with female connectors that provide the corresponding enclosure rating.

Ambient data

Ambient temperature	-20 °C ... +80 °C
Storage and transport temperature	-20 °C ... +80 °C
Relative humidity	45 % ... 75 %



Ordering information

The part numbers below show a selection of our common configurations and represent only a portion of the product portfolio. The type code on page E-174 indicates all possible configurations that can be ordered.

- **Electrical connection:** Round connector M12 x 1, 4-pin
- **Seal:** NBR

Output signal	Process connection	Insertion length/diameter of probe	Model name	Part no.
2 x PNP	Thread G ¼ A according DIN 3852-E	50 mm / 6 mm	TBS-1ASG10506NM	6048661
		100 mm / 6 mm	TBS-1ASG11006NM	6048662
		150 mm / 6 mm	TBS-1ASG11506NM	6048663
		250 mm / 6 mm	TBS-1ASG12506NM	6048664
	Thread G ½ A according DIN 3852-E	50 mm / 6 mm	TBS-1ASGT0506NM	6048665
		100 mm / 6 mm	TBS-1ASGT1006NM	6048666
		150 mm / 6 mm	TBS-1ASGT1506NM	6048667
		250 mm / 6 mm	TBS-1ASGT2506NM	6048668
1 x PNP + 4 mA ... 20 mA	Thread G ¼ A according DIN 3852-E	50 mm / 6 mm	TBS-1BSG10506NM	6048669
		100 mm / 6 mm	TBS-1BSG11006NM	6048670
		150 mm / 6 mm	TBS-1BSG11506NM	6048671
		250 mm / 6 mm	TBS-1BSG12506NM	6048672
	Thread G ½ A according DIN 3852-E	50 mm / 6 mm	TBS-1BSGT0506NM	6048673
		100 mm / 6 mm	TBS-1BSGT1006NM	6048674
		150 mm / 6 mm	TBS-1BSGT1506NM	6048675
		250 mm / 6 mm	TBS-1BSGT2506NM	6048676

- **Electrical connection:** Round connector M12 x 1, 5-pin
- **Seal:** NBR

Output signal	Process connection	Insertion length/diameter of probe	Model name	Part no.
2 x PNP + 4 mA ... 20 mA	Thread G ¼ A according DIN 3852-E	50 mm / 6 mm	TBS-1DSG10506NE	6048677
		100 mm / 6 mm	TBS-1DSG11006NE	6048678
		150 mm / 6 mm	TBS-1DSG11506NE	6048679
		250 mm / 6 mm	TBS-1DSG12506NE	6048680
	Thread G ½ A according DIN 3852-E	50 mm / 6 mm	TBS-1DSGT0506NE	6048681
		100 mm / 6 mm	TBS-1DSGT1006NE	6048682
		150 mm / 6 mm	TBS-1DSGT1506NE	6048683
		250 mm / 6 mm	TBS-1DSGT2506NE	6048684

Dimensional drawings

dimensions in mm (inch)

TBS with connection G 1/4 A according DIN 3852-E

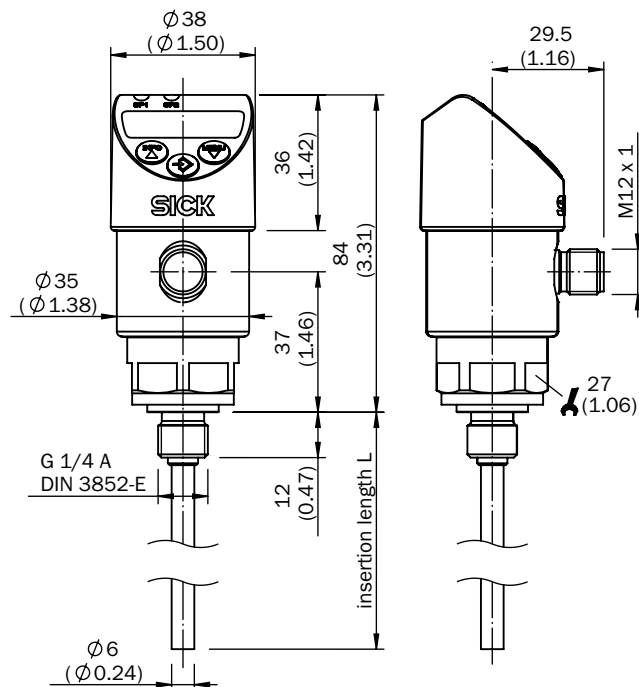

TBS with connection G 1/2 A according DIN 3852-E

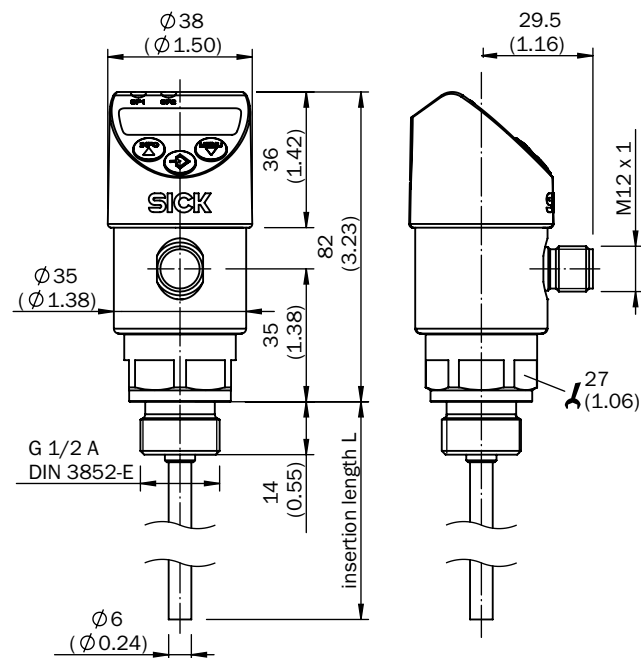

TBS with connection 1/4" NPT

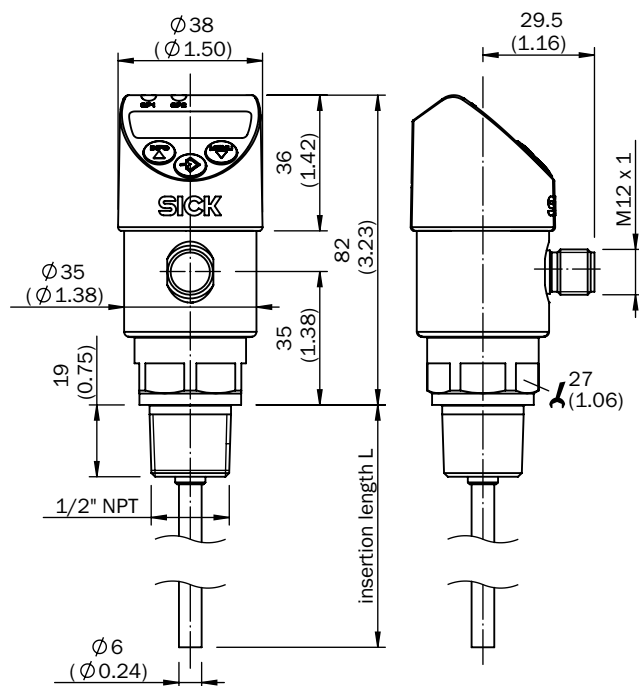



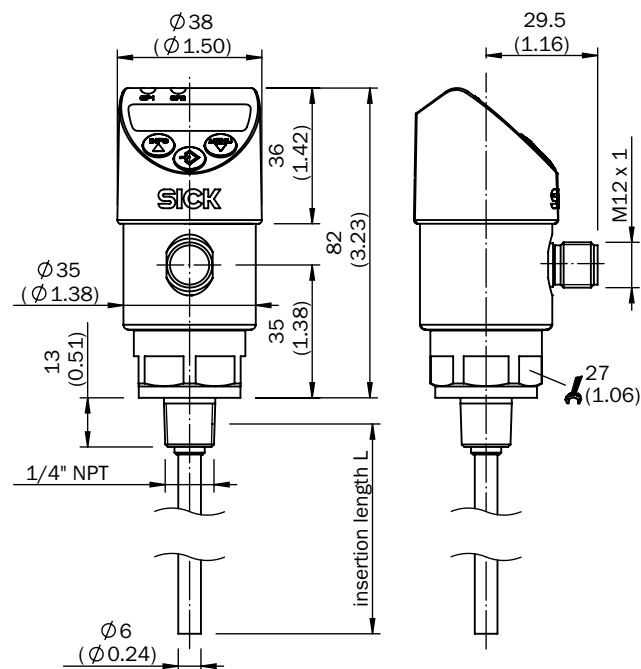

TBS with connection 1/2" NPT



Recommended accessories

Plug connectors and cables

- **Connector type:** Female connector
- **Connector:** Straight

	Electrical connection	Enclosure rating	Sheath material	Cable length	Model name	Part no.
	M12, 4-pin	IP 67	PVC	2 m	DOL-1204-G02M	6009382
				5 m	DOL-1204-G05M	6009866
		IP 68	PUR halogen free	2 m	DOL-1204-G02MC	6025900
				5 m	DOL-1204-G05MC	6025901
	M12, 5-pin	IP 67	PVC	2 m	DOL-1205-G02M	6008899
				5 m	DOL-1205-G05M	6009868
		IP 68	PUR halogen free	2 m	DOL-1205-G02MC	6025906
				5 m	DOL-1205-G05MC	6025907



Well-proven temperature measurement



Product description

The TBT is a universal purpose Pt100 resistance thermometer with a splash-proof die-cast aluminum housing for the temperature measurement in liquids and gases. It can be adapted to specific applications through its various available process connections and insertion lengths. The TBT is available with various

connection threads, with or without compression fittings. Wetted parts are made from high-grade stainless steel 1.4571. Besides its Pt100 output signal, the TBT is available with an integrated transmitter with output signal 4 mA ... 2 mA.

At a glance

- Pt100 element, accuracy class A according IEC 60751
- Measuring ranges $-50\text{ °C} \dots +150\text{ °C}$ and $-50\text{ °C} \dots +250\text{ °C}$
- Wetted parts made from corrosion resistant stainless steel 1.4571
- Various mechanical adaptations and insertion lengths
- Pt100 (4-wire) or 4 mA ... 20 mA (2-wire)
- Cable gland M16 x 1.5

Your benefits

- Reliable operation through rugged design and high-quality materials
- Good long-term stability, accuracy and linearity
- Quick and safe installation
- Convenient system integration even in narrow installation spaces
- Optimal solutions for individual requirements



Additional information

Detailed technical data	E-179
Ordering information	E-180
Type code	E-182
Dimensional drawings	E-182
Recommended accessories	E-184

→ www.mysick.com/en/TBT

For more information, just enter the link or scan the QR code and get direct access to technical data, CAD design models, operating instructions, software, application examples and much more.



Detailed technical data

Features

Measuring ranges	-50 °C ... +150 °C -50 °C ... +250 °C
Sensor element	Pt100
Signal outputs and maximum ohmic load R_A	Pt100, 4-wire 4 mA ... 20 mA, 2-wire ($R_A \leq (L^+ - 10 \text{ V}) / 0.028 \text{ A [Ohm]}$)

Performance

Accuracy of sensor element	Class A according IEC 60751
Accuracy of optional transmitter	$\leq \pm 0.1 \%$ of span
Linearity of optional transmitter	$\leq \pm 0.1 \%$ of span
Response time ¹⁾	Response time t_{50} : $\leq 5.8 \text{ s}$ Response time t_{90} : $\leq 15.5 \text{ s}$

¹⁾ Depending on sensor configuration, according to IEC 60751.

Mechanics/electronics

Process connection	See type code
Insertion lengths/diameter of probe ¹⁾	25 mm / 3 mm 50 mm / 3 mm 100 mm / 6 mm 150 mm / 6 mm 250 mm / 6 mm 350 mm / 6 mm
Wetted parts	Stainless steel 1.4571
Pressure resistance ²⁾	Max. 40 bar with supplied compression fitting with PTFE ferrule Max. 100 bar with supplied compression fitting with stainless steel ferrule Max. 120 bar with threaded process connection
Housing material	Aluminum
Electrical connection and enclosure rating ³⁾	Cable gland M16 x 1.5, IP 65 Cable gland M16 x 1.5, IP 67
Measuring current	0.3 mA ... 1 mA, for variant with output signal Pt100
Supply voltage	10 V DC ... 35 V DC for variant with transmitter 4 mA ... 20 mA
Maximum current consumption	Ca. 28 mA for variant with transmitter 4 mA ... 20 mA
Electrical safety	Protection class: III Dielectric strength: 500 V AC Reverse polarity protection of variant with transmitter 4 mA ... 20 mA: L ⁺ towards M
CE-conformity	2004/108/EC, EN 61326-2-3
RoHS certificate	✓
Weight	Ca. 155 g (depending on configuration)
Initialization time	< 1 ms

¹⁾ For measuring range -50 °C ... +250 °C insertion lengths from 50mm required.

²⁾ Pressure resistance at room temperature.

³⁾ Enclosure rating IP per IEC 60529. The enclosure rating classes specified only apply while the pressure transmitter is connected with female connectors that provide the corresponding enclosure rating.

Ambient data

Ambient temperature	-40 °C ... +85 °C for variant with transmitter 4 mA ... 20 mA -40 °C ... +125 °C for variant with output signal Pt100
Storage and transport temperature	-40 °C ... +60 °C
Shock resistance according to IEC 60751	500 g
Vibration resistance according to IEC 60751	3 g

Ordering information

The part numbers below show a selection of our common configurations and represent only a portion of the product portfolio. The type code on page E-182 indicates all possible configurations that can be ordered.

- **Measuring range:** -50 °C ... +150 °C
- **Electrical connection/enclosure rating:** Cable gland M16 x 1.5, IP 65

Output signal	Process connection	Insertion length/diameter of probe	Model name	Part no.
4 mA ... 20 mA, 2-wire	Thread G ¼ B	25 mm / 3 mm	TBT-1AAG10253GZ	6043044
		50 mm / 3 mm	TBT-1AAG10503GZ	6043045
		100 mm / 6 mm	TBT-1AAG11006GZ	6043046
		150 mm / 6 mm	TBT-1AAG11506GZ	6043047
		250 mm / 6 mm	TBT-1AAG12506GZ	6043048
		350 mm / 6 mm	TBT-1AAG13506GZ	6043049
	Thread G ½ B	25 mm / 3 mm	TBT-1AAGE0253GZ	6043050
		50 mm / 3 mm	TBT-1AAGE0503GZ	6043051
		100 mm / 6 mm	TBT-1AAGE1006GZ	6043052
		150 mm / 6 mm	TBT-1AAGE1506GZ	6043053
		250 mm / 6 mm	TBT-1AAGE2506GZ	6043054
		350 mm / 6 mm	TBT-1AAGE3506GZ	6043055
	Compression fitting G ¼ B, CrNi stainless steel ferrule	25 mm / 3 mm	TBT-1AAS10253GZ	6043059
		50 mm / 3 mm	TBT-1AAS10503GZ	6043060
		100 mm / 6 mm	TBT-1AAS11006GZ	6043061
		150 mm / 6 mm	TBT-1AAS11506GZ	6043062
		250 mm / 6 mm	TBT-1AAS12506GZ	6043063
		350 mm / 6 mm	TBT-1AAS13506GZ	6043064
	Compression fitting G ½ B, CrNi stainless steel ferrule	25 mm / 3 mm	TBT-1AASE0253GZ	6043065
		50 mm / 3 mm	TBT-1AASE0503GZ	6043066
		100 mm / 6 mm	TBT-1AASE1006GZ	6043067
		150 mm / 6 mm	TBT-1AASE1506GZ	6043068
		250 mm / 6 mm	TBT-1AASE2506GZ	6043069
		350 mm / 6 mm	TBT-1AASE3506GZ	6043070
Without process connection	25 mm / 3 mm	TBT-1AAZZ0253GZ	6043038	
	50 mm / 3 mm	TBT-1AAZZ0503GZ	6043039	
	100 mm / 6 mm	TBT-1AAZZ1006GZ	6043040	
	150 mm / 6 mm	TBT-1AAZZ1506GZ	6043041	
	250 mm / 6 mm	TBT-1AAZZ2506GZ	6043042	
	350 mm / 6 mm	TBT-1AAZZ3506GZ	6043043	

E

Output signal	Process connection	Insertion length/diameter of probe	Model name	Part no.
Pt100, 4-wire	Thread G ¼ B	25 mm / 3 mm	TBT-1PAG10253GZ	6043014
		50 mm / 3 mm	TBT-1PAG10503GZ	6043015
		100 mm / 6 mm	TBT-1PAG11006GZ	6043016
		150 mm / 6 mm	TBT-1PAG11506GZ	6043017
		250 mm / 6 mm	TBT-1PAG12506GZ	6043018
		350 mm / 6 mm	TBT-1PAG13506GZ	6043019
	Thread G ½ B	25 mm / 3 mm	TBT-1PAGE0253GZ	6043020
		50 mm / 3 mm	TBT-1PAGE0503GZ	6043021
		100 mm / 6 mm	TBT-1PAGE1006GZ	6043022
		150 mm / 6 mm	TBT-1PAGE1506GZ	6043023
		250 mm / 6 mm	TBT-1PAGE2506GZ	6043024
		350 mm / 6 mm	TBT-1PAGE3506GZ	6043025
	Compression fitting G ¼ B, CrNi stainless steel ferrule	25 mm / 3 mm	TBT-1PAS10253GZ	6043026
		50 mm / 3 mm	TBT-1PAS10503GZ	6043027
		100 mm / 6 mm	TBT-1PAS11006GZ	6043028
		150 mm / 6 mm	TBT-1PAS11506GZ	6043029
		250 mm / 6 mm	TBT-1PAS12506GZ	6043030
		350 mm / 6 mm	TBT-1PAS13506GZ	6043031
	Compression fitting G ½ B, CrNi stainless steel ferrule	25 mm / 3 mm	TBT-1PASE0253GZ	6043032
		50 mm / 3 mm	TBT-1PASE0503GZ	6043033
		100 mm / 6 mm	TBT-1PASE1006GZ	6043034
		150 mm / 6 mm	TBT-1PASE1506GZ	6043035
		250 mm / 6 mm	TBT-1PASE2506GZ	6043036
		350 mm / 6 mm	TBT-1PASE3506GZ	6043037
	Without process connection	25 mm / 3 mm	TBT-1PAZZ0253GZ	6043007
		50 mm / 3 mm	TBT-1PAZZ0503GZ	6043008
		100 mm / 6 mm	TBT-1PAZZ1006GZ	6043009
		150 mm / 6 mm	TBT-1PAZZ1506GZ	6043010
		250 mm / 6 mm	TBT-1PAZZ2506GZ	6043011
		350 mm / 6 mm	TBT-1PAZZ3506GZ	6043013

Type code

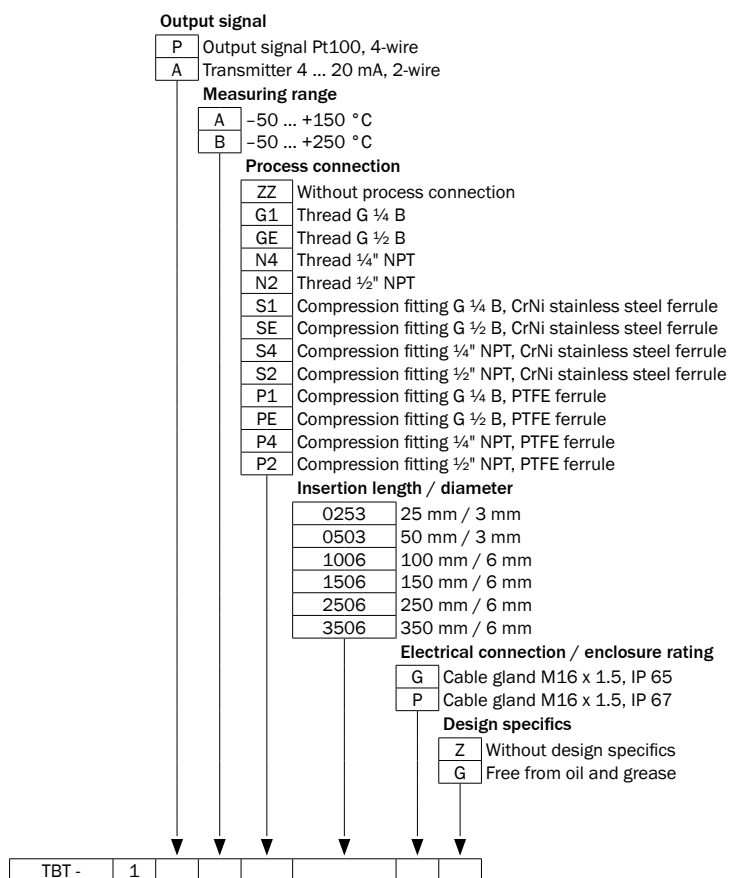

Not all variations of the type code can be combined!

Dimensional drawings

dimensions in mm (inch)

Housing, without process connection

With cable gland IP 65

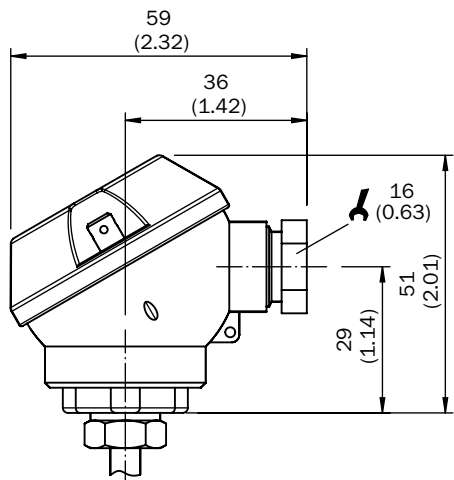

With cable gland IP 67

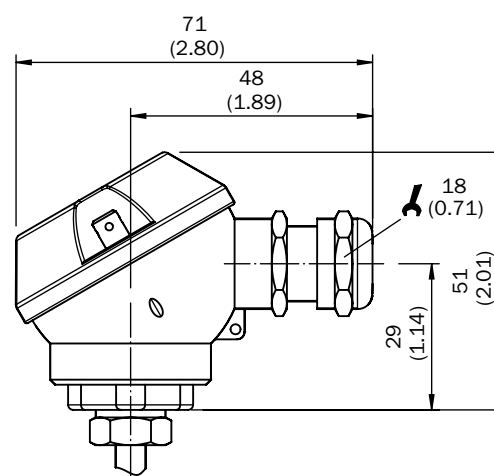

E

Process connections, cylindrical threads

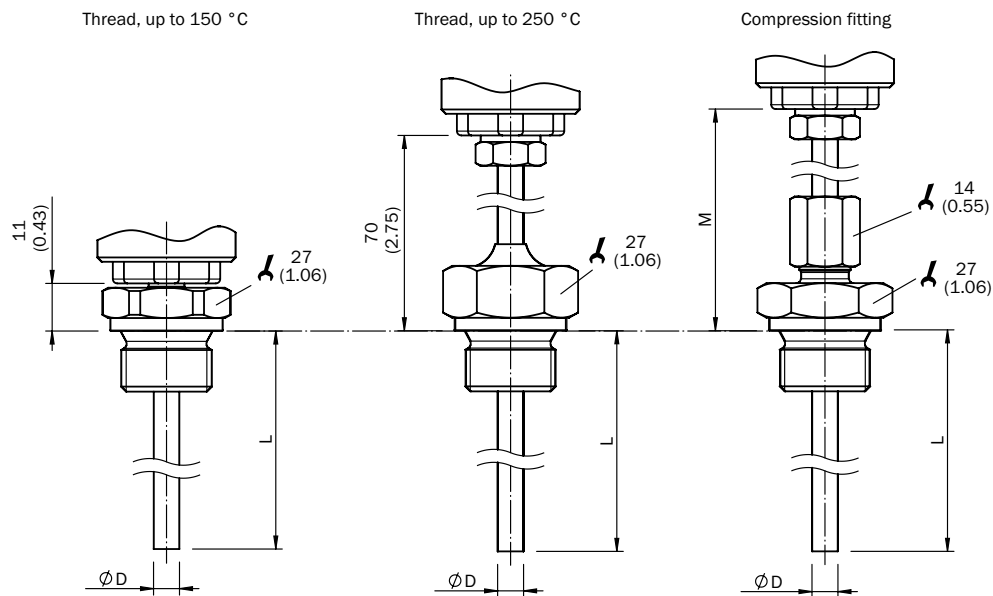



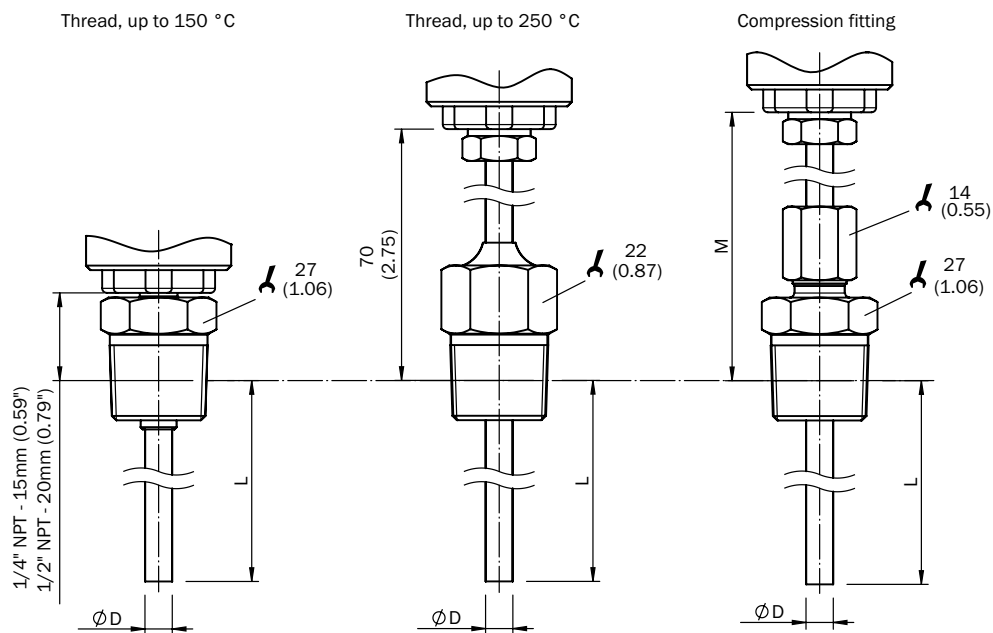

Process connections, conical threads



Recommended accessories

Plug connectors and cables

- **Connector type:** Female connector
- **Electrical connection:** Round connector M12 x 1, 4-pin

	Enclosure rating	Sheath material	connector	Cable length	Model name	Part no.
	IP 67	PVC	Straight	2 m	DOL-1204-G02M	6009382
				5 m	DOL-1204-G05M	6009866
				10 m	DOL-1204-G10M	6010543
				15 m	DOL-1204-G15M	6010753
	IP 67	PVC	Angled	2 m	DOL-1204-W02M	6009383
				5 m	DOL-1204-W05M	6009867
				10 m	DOL-1204-W10M	6010541
	IP 68	PUR halogen free	Straight	2 m	DOL-1204-G02MC	6025900
				5 m	DOL-1204-G05MC	6025901
				10 m	DOL-1204-G10MC	6025902
	IP 68	PUR halogen free	Angled	2 m	DOL-1204-W02MC	6025903
				5 m	DOL-1204-W05MC	6025904
				10 m	DOL-1204-W10MC	6025905



Compact, rugged, precise



Product description

The TCT is a Pt100 universal purpose resistance thermometer in a compact stainless steel housing for the temperature measurement in liquids and gases. It can be adapted to specific applications through its various available process connections and insertion lengths. It is available with various connection threads, with or without

compression fittings. In addition, there are configurations available with thermowells. Wetted parts are made from high-grade stainless steel 1.4571. Besides its Pt100 output signal, the TCT is available with an integrated transmitter with output signal 4 mA ... 20 mA.

At a glance

- Pt100 element, accuracy class A according IEC 60751
- Measuring ranges $-50\text{ °C} \dots +150\text{ °C}$ and $-50\text{ °C} \dots +250\text{ °C}$
- Wetted parts made from corrosion resistant stainless steel 1.4571
- Various mechanical adaptations and insertion lengths, also available with thermowell
- Pt100 (4-wire) or 4 mA ... 20 mA (2-wire)
- Circular connector M12 x 1 (IP 67) or L-connector according to DIN EN 175301-803 A (IP 65)

Your benefits

- Reliable operation through rugged design and high-quality materials
- Good long-term stability, accuracy and linearity
- Quick and safe installation
- Convenient system integration through compact dimensions and industry-standard output signals
- Optimal solutions for individual requirements



Additional information

Detailed technical data.	E-187
Ordering information.	E-188
Type code.	E-190
Dimensional drawings	E-191
Recommended accessories.	E-193

→ www.mysick.com/en/TCT

For more information, just enter the link or scan the QR code and get direct access to technical data, CAD design models, operating instructions, software, application examples and much more.



Detailed technical data

Features

Measuring ranges	-50 °C ... +150 °C -50 °C ... +250 °C
Sensor element	Pt100
Signal outputs and maximum ohmic load R_A	Pt100, 4-wire 4 mA ... 20 mA, 2-wire ($R_A \leq (L^+ - 9 V) / 0.023 A [Ohm]$)

Performance

Accuracy of sensor element	Class A according IEC 60751
Accuracy of optional transmitter	$\leq \pm 0.2 \%$ of span
Linearity of optional transmitter	$\leq \pm 0.1 \%$ of span
Response time ¹⁾	Response time t_{50} : ≤ 2.8 s Response time t_{90} : ≤ 9.1 s

¹⁾ Depending on sensor configuration according to IEC 60751.

Mechanics/electronics

Process connection	See type code
Insertion lengths / diameter of probe ¹⁾	25 mm / 3 mm 50 mm / 3 mm 100 mm / 6 mm 150 mm / 6 mm 250 mm / 6 mm 350 mm / 6 mm
Wetted parts	Stainless steel 1.4571
Pressure resistance ²⁾	Max. 40 bar with supplied compression fitting with PTFE ferrule Max. 100 bar with supplied compression fitting with stainless steel ferrule Max. 120 bar with threaded process connection, max. 220 bar with variants with thermowell Max. 220 bar with variants with thermowell
Housing material	Stainless steel 1.4571
Electrical connection and enclosure rating ³⁾	Round connector M12 x 1, 4-pin, IP 67 L-connector (DIN EN 175301-803 A), 4 pin, IP 65
Measuring current	0.3 mA ... 1 mA, (for variant with output signal Pt100)
Supply voltage	10 V DC ... 36 V DC for variant with transmitter 4 mA ... 20 mA
Maximum current consumption	Ca. 30 mA for variant with transmitter 4 mA ... 20 mA
Electrical safety	Protection class: III Dielectric strength: 500 V AC Reverse polarity protection of variant with transmitter 4 mA ... 20 mA: L ⁺ towards M
CE-conformity	2004/108/EC, EN 61326-2-3
RoHS certificate	✓
Weight	Ca. 145 g (depending on configuration)
Initialization time	< 10 ms

¹⁾ For measuring range -50 °C ... +250 °C insertion lengths from 50 mm required.

²⁾ Pressure resistance at room temperature.

³⁾ Enclosure rating IP per IEC 60529. The enclosure rating classes specified only apply while the pressure transmitter is connected with female connectors that provide the corresponding enclosure rating.

Ambient data

Ambient temperature	-40 °C ... +85 °C for variant with transmitter 4 mA ... 20 mA -40 °C ... +85 °C for variant with output signal Pt100 and L-connector (DIN EN 175301-803 A) -40 °C ... +125 °C for variant with output signal Pt100 and round connector M12 x 1
Storage and transport temperature	-40 °C ... +85 °C
Shock resistance according to IEC 60751	500 g
Vibration resistance according to IEC 60751	3 g

Ordering information

The part numbers below show a selection of our common configurations and represent only a portion of the product portfolio. The type code on page E-190 indicates all possible configurations that can be ordered.

- **Measuring range:** -50 °C ... +150 °C
- **Electrical connection/enclosure rating:** Round connector M12 x 1, 4-pin, IP 67

Output signal	Process connection	Insertion length/diameter of probe	Model name	Part no.
4 mA ... 20 mA, 2-wire	Thread G ¼ B	25 mm / 3 mm	TCT-1AAG10253MZ	6043210
		50 mm / 3 mm	TCT-1AAG10503MZ	6043211
		100 mm / 6 mm	TCT-1AAG11006MZ	6043212
		150 mm / 6 mm	TCT-1AAG11506MZ	6043213
		250 mm / 6 mm	TCT-1AAG12506MZ	6043214
		350 mm / 6 mm	TCT-1AAG13506MZ	6043215
	Thread G ½ B	25 mm / 3 mm	TCT-1AAGE0253MZ	6043216
		50 mm / 3 mm	TCT-1AAGE0503MZ	6043217
		100 mm / 6 mm	TCT-1AAGE1006MZ	6043218
		150 mm / 6 mm	TCT-1AAGE1506MZ	6043219
		250 mm / 6 mm	TCT-1AAGE2506MZ	6043220
		350 mm / 6 mm	TCT-1AAGE3506MZ	6043221
	Compression fitting G ¼ B, stainless steel ferrule	25 mm / 3 mm	TCT-1AAS10253MZ	6043222
		50 mm / 3 mm	TCT-1AAS10503MZ	6043223
		100 mm / 6 mm	TCT-1AAS11006MZ	6043224
		150 mm / 6 mm	TCT-1AAS11506MZ	6043225
		250 mm / 6 mm	TCT-1AAS12506MZ	6043226
		350 mm / 6 mm	TCT-1AAS13506MZ	6043227
	Compression fitting G ½ B, stainless steel ferrule	25 mm / 3 mm	TCT-1AASE0253MZ	6043228
		50 mm / 3 mm	TCT-1AASE0503MZ	6043229
		100 mm / 6 mm	TCT-1AASE1006MZ	6043230
		150 mm / 6 mm	TCT-1AASE1506MZ	6043231
		250 mm / 6 mm	TCT-1AASE2506MZ	6043232
		350 mm / 6 mm	TCT-1AASE3506MZ	6043233
	Without process connection	25 mm / 3 mm	TCT-1AAZZ0253MZ	6043201
		50 mm / 3 mm	TCT-1AAZZ0503MZ	6043202
		100 mm / 6 mm	TCT-1AAZZ1006MZ	6043203
		150 mm / 6 mm	TCT-1AAZZ1506MZ	6043204
		250 mm / 6 mm	TCT-1AAZZ2506MZ	6043205
		350 mm / 6 mm	TCT-1AAZZ3506MZ	6043206

Output signal	Process connection	Insertion length/diameter of probe	Model name	Part no.
4 mA ... 20 mA, 2-wire	Thermowell G ¼ B	100 mm / 6 mm	TCT-1AAT11006MZ	6043234
		150 mm / 6 mm	TCT-1AAT11506MZ	6043235
		250 mm / 6 mm	TCT-1AAT12506MZ	6043236
		350 mm / 6 mm	TCT-1AAT13506MZ	6043237
	Thermowell G ½ B	100 mm / 6 mm	TCT-1AATE1006MZ	6043238
		150 mm / 6 mm	TCT-1AATE1506MZ	6043239
		250 mm / 6 mm	TCT-1AATE2506MZ	6043240
		350 mm / 6 mm	TCT-1AATE3506MZ	6043241
Pt100, 4-wire	Thread G ¼ B	25 mm / 3 mm	TCT-1PAG10253MZ	6043164
		50 mm / 3 mm	TCT-1PAG10503MZ	6043165
		100 mm / 6 mm	TCT-1PAG11006MZ	6043166
		150 mm / 6 mm	TCT-1PAG11506MZ	6043167
		250 mm / 6 mm	TCT-1PAG12506MZ	6043168
		350 mm / 6 mm	TCT-1PAG13506MZ	6043169
	Thread G ½ B	25 mm / 3 mm	TCT-1PAGE0253MZ	6043170
		50 mm / 3 mm	TCT-1PAGE0503MZ	6043172
		100 mm / 6 mm	TCT-1PAGE1006MZ	6043173
		150 mm / 6 mm	TCT-1PAGE1506MZ	6043174
		250 mm / 6 mm	TCT-1PAGE2506MZ	6043175
		350 mm / 6 mm	TCT-1PAGE3506MZ	6043176
	Compression fitting G ¼ B, stainless steel ferrule	25 mm / 3 mm	TCT-1PAS10253MZ	6043177
		50 mm / 3 mm	TCT-1PAS10503MZ	6043178
		100 mm / 6 mm	TCT-1PAS11006MZ	6043179
		150 mm / 6 mm	TCT-1PAS11506MZ	6043180
		250 mm / 6 mm	TCT-1PAS12506MZ	6043181
		350 mm / 6 mm	TCT-1PAS13506MZ	6043183
	Compression fitting G ½ B, stainless steel ferrule	25 mm / 3 mm	TCT-1PASE0253MZ	6043185
		50 mm / 3 mm	TCT-1PASE0503MZ	6043186
		100 mm / 6 mm	TCT-1PASE1006MZ	6043187
		150 mm / 6 mm	TCT-1PASE1506MZ	6043188
		250 mm / 6 mm	TCT-1PASE2506MZ	6043189
		350 mm / 6 mm	TCT-1PASE3506MZ	6043190
	Without process connection	25 mm / 3 mm	TCT-1PAZZ0253MZ	6043158
		50 mm / 3 mm	TCT-1PAZZ0503MZ	6043159
		100 mm / 6 mm	TCT-1PAZZ1006MZ	6043160
		150 mm / 6 mm	TCT-1PAZZ1506MZ	6043161
		250 mm / 6 mm	TCT-1PAZZ2506MZ	6043162
		350 mm / 6 mm	TCT-1PAZZ3506MZ	6043163
	Thermowell G ¼ B	100 mm / 6 mm	TCT-1PAT11006MZ	6043193
		150 mm / 6 mm	TCT-1PAT11506MZ	6043194
		250 mm / 6 mm	TCT-1PAT12506MZ	6043195
		350 mm / 6 mm	TCT-1PAT13506MZ	6043196
	Thermowell G ½ B	100 mm / 6 mm	TCT-1PATE1006MZ	6043197
		150 mm / 6 mm	TCT-1PATE1506MZ	6043198
		250 mm / 6 mm	TCT-1PATE2506MZ	6043199
		350 mm / 6 mm	TCT-1PATE3506MZ	6043200

Type code

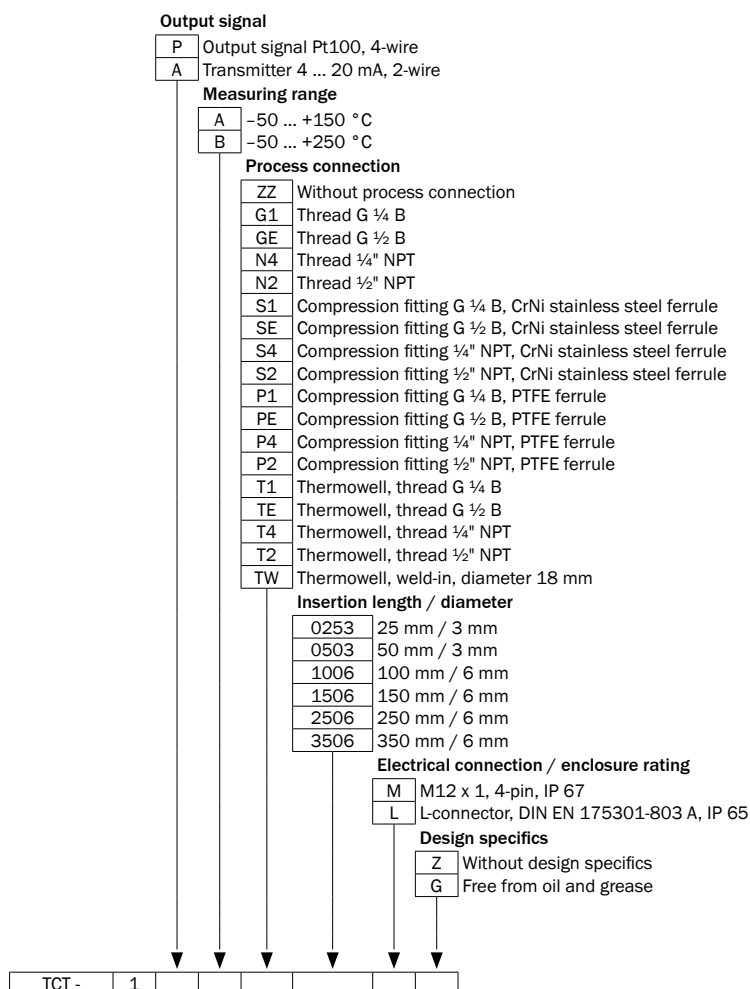

Not all variations of the type code can be combined!



Dimensional drawings

dimensions in mm (inch)

Housing, without process connection

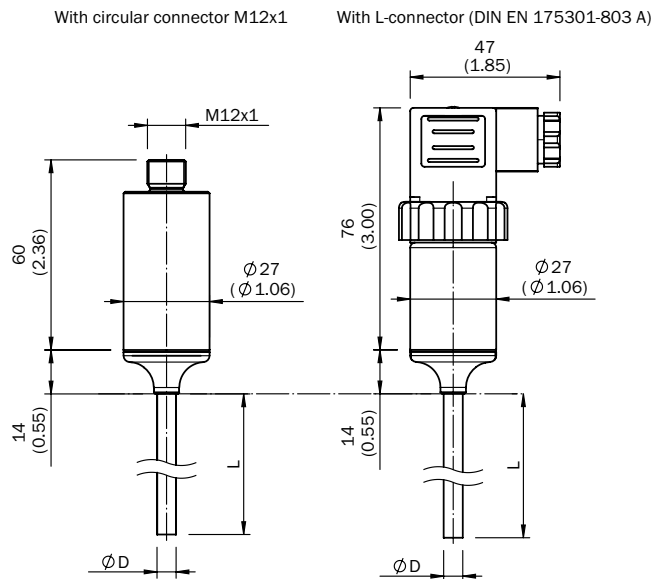

Process connections, cylindrical threads

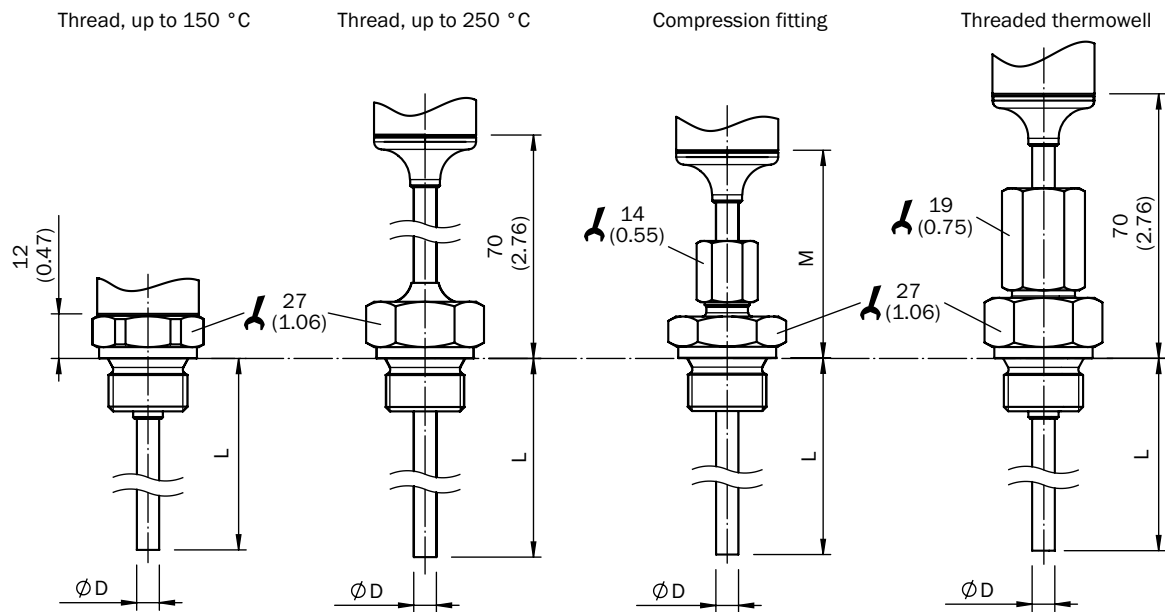

Process connections, conical threads

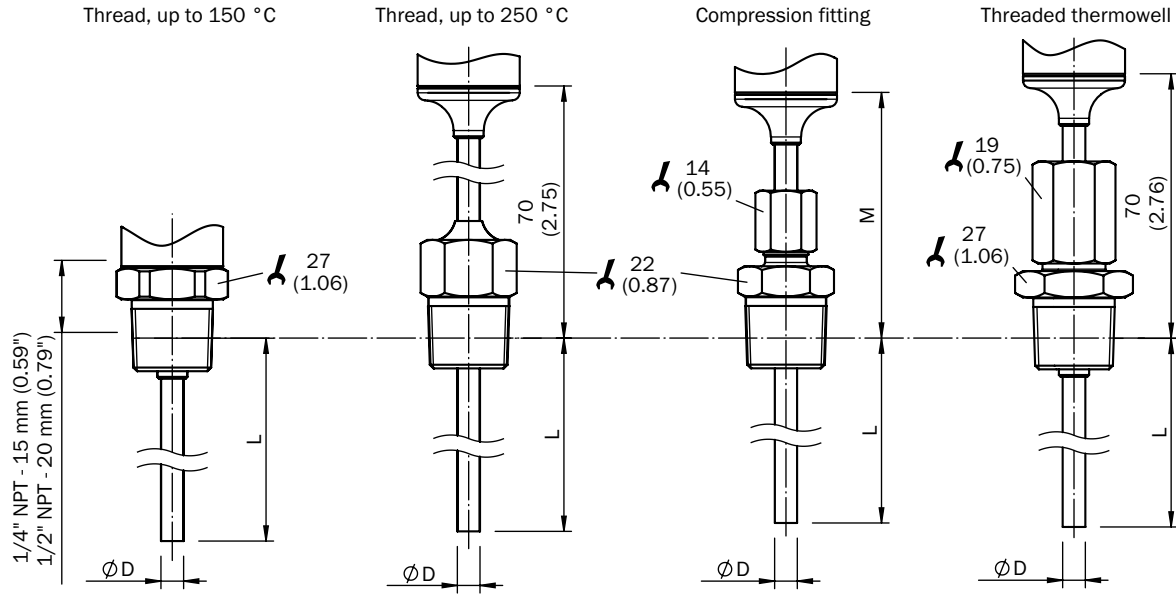



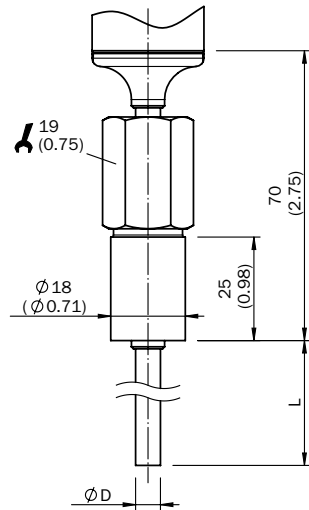

Process connection, weld-in thermowell



Recommended accessories

Plug connectors and cables

- **Connector type:** Female connector
- **Electrical connection:** Round connector M12 x 1, 4-pin

	Enclosure rating	Sheath material	Connector	Cable length	Model name	Part no.
	IP 67	PVC	Straight	2 m	DOL-1204-G02M	6009382
				5 m	DOL-1204-G05M	6009866
				10 m	DOL-1204-G10M	6010543
				15 m	DOL-1204-G15M	6010753
			Angled	2 m	DOL-1204-W02M	6009383
				5 m	DOL-1204-W05M	6009867
				10 m	DOL-1204-W10M	6010541
			IP 68	PUR halogen free	Straight	2 m
	5 m	DOL-1204-G05MC				6025901
	10 m	DOL-1204-G10MC				6025902
	Angled	2 m			DOL-1204-W02MC	6025903
		5 m			DOL-1204-W05MC	6025904
		10 m			DOL-1204-W10MC	6025905

Efficient and space-saving temperature measurement



Additional information

Detailed technical data	E-195
Ordering information	E-196
Type code	E-197
Dimensional drawings	E-197
Recommended accessories	E-198

Product description

The TSP is a universal purpose platinum insertion thermometer for the temperature measurement in liquids and gases. It can be adapted to specific applications through its available connection threads and insertion lengths. Wetted parts are made from stainless steel 1.4305. The platinum

resistor (Pt100 or Pt1000, accuracy class B according to IEC 60751) is located inside the tip of the probe. It is electrically connected by an M12 x 1 circular connector. Therefore, the device is compact and well-suited for narrow installation spaces.

At a glance

- Platinum element (Pt100 or Pt1000, 2-wire or 3-wire), accuracy class B according to IEC 60751
- Measuring range -30 °C ... +130 °C
- Various connection threads and insertion lengths
- Wetted parts made from stainless steel 1.4305
- Circular connector M12 x 1 (IP 67)

Your benefits

- Reliable operation through rugged design and high-quality materials
- Good long-term stability
- Easy installation
- Convenient system integration through very compact dimensions

→ www.mysick.com/en/TSP

For more information, just enter the link or scan the QR code and get direct access to technical data, CAD design models, operating instructions, software, application examples and much more.



Detailed technical data

Features

Measuring range	-30 °C ... +130 °C
Sensor element	Pt100 or Pt1000
Output signals	Pt100, 2-wire Pt1000, 2-wire Pt100, 3-wire Pt1000, 3-wire

Performance

Accuracy of sensor element	Class B according to IEC 60751
Response time ¹⁾	Response time t_{50} : ≤ 2.5 s Response time t_{90} : ≤ 6 s

¹⁾ Depending on sensor configuration according to IEC 60751.

Mechanics/electronics

Process connection	See type code
Insertion lengths/diameter of probe	30 mm / 5 mm 40 mm / 5 mm 50 mm / 6 mm 60 mm / 6 mm
Wetted parts	Stainless steel 1.4305
Pressure resistance	Max. 120 bar
Housing material	Stainless steel 1.4305
Electrical connection and enclosure rating ¹⁾	Round connector M12 x 1, 4-pin, IP 67
Measuring current	0.1 mA ... 0.3 mA, Pt1000 0.3 mA ... 1 mA, Pt100
Electrical safety	Protection class: III Dielectric strength: 500 V AC
RoHS certificate	✓
Weight	Ca. 30 g (depending on configuration)

¹⁾ Enclosure rating IP per IEC 60529. The enclosure rating classes specified only apply while the pressure transmitter is connected with female connectors that provide the corresponding enclosure rating.

Ambient data

Ambient temperature ¹⁾	-40 °C ... +100 °C
Storage and transport temperature	-40 °C ... +85 °C
Shock resistance according to IEC 60751	500 g
Vibration resistance according to IEC 60751	3 g

¹⁾ Due to the short overall length, the temperature at the connection plug may rise to inadmissibly high values. It is essential to avoid this with a corresponding design of the test point. The connection cable has to be selected accordingly.



Ordering information

The part numbers below show a selection of our common configurations and represent only a portion of the product portfolio. The type code on page E-197 indicates all possible configurations that can be ordered.

- **Electrical connection:** Round connector M12 x 1, 4-pin, IP 67

Output signal	Process connection	Insertion length/diameter of probe	Model name	Part no.
Pt100, 2-wire	Thread G ¼ B	30 mm / 5 mm	TSP-1PAG10305MZ	6042938
		40 mm / 5 mm	TSP-1PAG10405MZ	6042939
		50 mm / 6 mm	TSP-1PAG10506MZ	6042940
		60 mm / 6 mm	TSP-1PAG10606MZ	6042941
	Thread G ⅜ B	30 mm / 5 mm	TSP-1PAG30305MZ	6042942
		40 mm / 5 mm	TSP-1PAG30405MZ	6042943
		50 mm / 6 mm	TSP-1PAG30506MZ	6042944
		60 mm / 6 mm	TSP-1PAG30606MZ	6042945
	Thread M14 x 1.5	30 mm / 5 mm	TSP-1PAM10305MZ	6042946
		40 mm / 5 mm	TSP-1PAM10405MZ	6042947
		50 mm / 6 mm	TSP-1PAM10506MZ	6042948
		60 mm / 6 mm	TSP-1PAM10606MZ	6042949
	Thread ¼" NPT	30 mm / 5 mm	TSP-1PAN40305MZ	6042950
		40 mm / 5 mm	TSP-1PAN40405MZ	6042951
		50 mm / 6 mm	TSP-1PAN40506MZ	6042952
		60 mm / 6 mm	TSP-1PAN40606MZ	6042953
Pt1000, 2-wire	Thread G ¼ B	30 mm / 5 mm	TSP-1MAG10305MZ	6042954
		40 mm / 5 mm	TSP-1MAG10405MZ	6042955
		50 mm / 6 mm	TSP-1MAG10506MZ	6042956
		60 mm / 6 mm	TSP-1MAG10606MZ	6042957
	Thread G ⅜ B	30 mm / 5 mm	TSP-1MAG30305MZ	6042958
		40 mm / 5 mm	TSP-1MAG30405MZ	6042959
		50 mm / 6 mm	TSP-1MAG30506MZ	6042960
		60 mm / 6 mm	TSP-1MAG30606MZ	6042961
	Thread M14 x 1.5	30 mm / 5 mm	TSP-1MAM10305MZ	6042962
		40 mm / 5 mm	TSP-1MAM10405MZ	6042963
		50 mm / 6 mm	TSP-1MAM10506MZ	6042964
		60 mm / 6 mm	TSP-1MAM10606MZ	6042965
	Thread ¼" NPT	30 mm / 5 mm	TSP-1MAN40305MZ	6042966
		40 mm / 5 mm	TSP-1MAN40405MZ	6042967
		50 mm / 6 mm	TSP-1MAN40506MZ	6042968
		60 mm / 6 mm	TSP-1MAN40606MZ	6042969

E

Type code

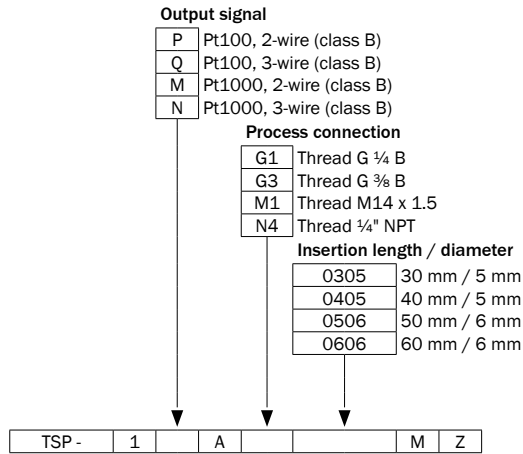



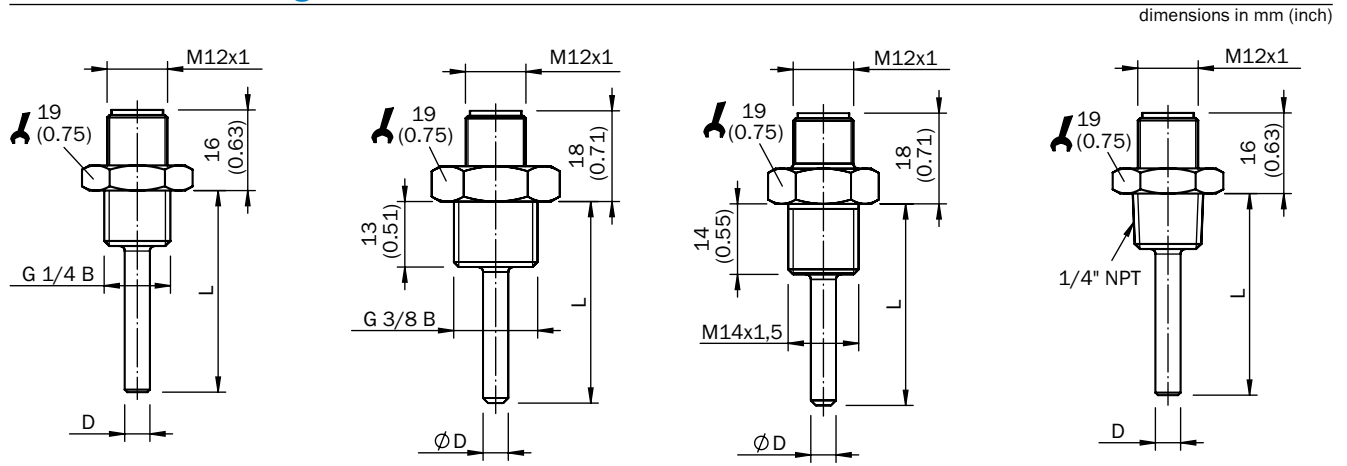

Dimensional drawings



Recommended accessories

Plug connectors and cables

- **Connector type:** Female connector
- **Electrical connection:** Round connector M12 x 1, 4-pin

	Enclosure rating	Sheath material	Connector	Cable length	Model name	Part no.
	IP 67	PVC	Straight	2 m	DOL-1204-G02M	6009382
				5 m	DOL-1204-G05M	6009866
				10 m	DOL-1204-G10M	6010543
				15 m	DOL-1204-G15M	6010753
	IP 67	PVC	Angled	2 m	DOL-1204-W02M	6009383
				5 m	DOL-1204-W05M	6009867
				10 m	DOL-1204-W10M	6010541
	IP 68	PUR halogen free	Straight	2 m	DOL-1204-G02MC	6025900
				5 m	DOL-1204-G05MC	6025901
				10 m	DOL-1204-G10MC	6025902
	IP 68	PUR halogen free	Angled	2 m	DOL-1204-W02MC	6025903
				5 m	DOL-1204-W05MC	6025904
				10 m	DOL-1204-W10MC	6025905



Simple, hygienic temperature measurement



Product description

The THTS temperature sensor is a compact, hygienic-grade, cost-effective Pt100 resistance thermometer. It is designed for applications in the food and beverage industry as well as in the cosmetics and pharmaceutical segment.

Due to the use of high-grade stainless steel and a crevice-free design of the wetted parts, stringent hygienic requirements are met.

The range of common hygienic process connections that are welded gap-free to the connection housing and multiple insertion lengths allow universal use.

The THTS is well-suited for CIP and SIP processes. This enables safe hygienic operation in conjunction with optimized system availability. Besides its direct electrical connection to the Pt100 element, the THTS is available with an integrated transmitter with 4 mA ... 20 mA output signal.

At a glance

- Pt100 element, accuracy class A (IEC 60751)
- Measuring ranges $-50\text{ °C} \dots +150\text{ °C}$ and $-50\text{ °C} \dots +250\text{ °C}$
- Wetted parts: Corrosion-resistant stainless steel 316L/1.4435, $Ra \leq 0.8\text{ }\mu\text{m}$
- Various hygienic process connections and insertion lengths
- Pt100 (4-wire) or 4 mA ... 20 mA (2-wire)
- Round connector M12 x 1

Your benefits

- Convenient system integration – installation in narrow installation space possible through compact dimensions
- Safe, hygienic operation due to wetted parts made from high-grade stainless steel, hygienic-grade surface finish and a gap- and crevice-free design
- Rugged: Connection housing is easy to clean and splash-proof
- Quick and safe installation
- Very good long-term stability, accuracy and linearity
- Quick response time
- Optimal solutions for individual requirements due to versatile configurability



Additional information

Detailed technical data.	E-201
Ordering information.	E-202
Type code.	E-203
Dimensional drawings	E-204
Recommended accessories.	E-184

→ www.mysick.com/en/THTS

For more information, just enter the link or scan the QR code and get direct access to technical data, CAD design models, operating instructions, software, application examples and much more.



Detailed technical data

Features

Measuring ranges	-50 °C ... +150 °C -50 °C ... +250 °C
Sensor element	Pt100
Signal outputs and maximum ohmic load R_A	Pt100, 4-wire 4 mA ... 20 mA, 2-wire ($R_A \leq (L^+ - 10 \text{ V}) / 0.023 \text{ A [Ohm]}$)

Performance

Accuracy of sensor element	Class A according IEC 60751
Accuracy of optional transmitter	$\leq \pm 0.2 \%$ of span
Linearity of optional transmitter	$\leq \pm 0.1 \%$ of span
Response time ¹⁾	
Response time t_{50}	$\leq 3.3 \text{ s}$
Response time t_{90}	$\leq 9.7 \text{ s}$

¹⁾ Depending on sensor configuration, according to IEC 60751.

Mechanics/electronics

Process connection	See type code
Insertion lengths/diameter of probe	25 mm / 6 mm 50 mm / 6 mm 75 mm / 6 mm 100 mm / 6 mm 150 mm / 6 mm 200 mm / 6 mm
Wetted parts	Stainless steel 1.4435 (316L), $R_a \leq 0.8 \mu\text{m}$
Pressure resistance ¹⁾	16 bar with clamp connections according to DIN 32676, ISO 2852 and tri-clamp 40 bar with conical coupling (DIN 11851) DN 20, DN 25, DN 32 and DN 40 with union nut 25 bar with conical coupling (DIN 11851) DN 50 with union nut 25 bar with Varivent connector form B, DN 10, DN 15 25 bar with Varivent connector form F 16 bar with Varivent connector form N
Housing material	Stainless steel 1.4571 (316Ti)
Enclosure rating ²⁾	IP 68 and IP 69K
Electrical connection	Round connector M12 x 1, 4-pin
Measuring current	0.3 mA ... 1 mA, for variant with output signal Pt100
Supply voltage	10 V DC ... 35 V DC for variant with transmitter 4 mA ... 20 mA
Maximum current consumption	Ca. 30 mA for variant with transmitter 4 mA ... 20 mA
Electrical safety	Protection class: III Dielectric strength: 500 V AC Reverse polarity protection of variant with transmitter 4 mA ... 20 mA: L ⁺ towards M
CE-conformity	2004/108/EC, EN 61326-2-3
RoHS certificate	✓
Initialization time	< 10 ms

¹⁾ Pressure resistance at room temperature.

²⁾ Enclosure rating IP 68 per IEC 60529 and IP 69K per DIN 40 050-1. The enclosure rating classes specified only apply while the pressure transmitter is connected with female connectors that provide the corresponding enclosure rating.

Ambient data

Ambient temperature	-40 °C ... +85 °C
Storage and transport temperature	-40 °C ... +85 °C
Shock resistance	According to IEC 60751
Vibration resistance according to IEC 60751	3 g
Relative humidity	≤ 95 %

Ordering information

The part numbers below show a selection of our common configurations and represent only a portion of the product portfolio. The type code on page E-203 indicates all possible configurations that can be ordered.

- **Measuring range:** -50 °C ... +150 °C
- **Electrical connection/enclosure rating:** Round connector M12 x 1, 4-pin, IP 68 and IP 69K

Output signal	Process connection	Insertion length/diameter of probe	Model name	Part no.	
4 mA ... 20 mA, 2-wire	Conical coupling (DIN 11851) DN 40 with union nut	25 mm / 6 mm	THTS-1AA540256MZ	6047609	
		50 mm / 6 mm	THTS-1AA540506MZ	6047610	
		75 mm / 6 mm	THTS-1AA540756MZ	6047611	
		100 mm / 6 mm	THTS-1AA541006MZ	6047612	
		150 mm / 6 mm	THTS-1AA541506MZ	6047613	
		200 mm / 6 mm	THTS-1AA542006MZ	6047614	
	Tri-Clamp 1", 1 ½"	25 mm / 6 mm	THTS-1AAT10256MZ	6047603	
		50 mm / 6 mm	THTS-1AAT10506MZ	6047604	
		75 mm / 6 mm	THTS-1AAT10756MZ	6047605	
		100 mm / 6 mm	THTS-1AAT11006MZ	6047606	
		150 mm / 6 mm	THTS-1AAT11506MZ	6047607	
		200 mm / 6 mm	THTS-1AAT12006MZ	6047608	
	Pt100, 4-wire	Conical coupling (DIN 11851) DN 40 with union nut	25 mm / 6 mm	THTS-1PA540256MZ	6047594
			50 mm / 6 mm	THTS-1PA540506MZ	6047596
75 mm / 6 mm			THTS-1PA540756MZ	6047597	
100 mm / 6 mm			THTS-1PA541006MZ	6047599	
150 mm / 6 mm			THTS-1PA541506MZ	6047600	
200 mm / 6 mm			THTS-1PA542006MZ	6047602	
Tri-Clamp 1", 1 ½"		25 mm / 6 mm	THTS-1PAT10256MZ	6047587	
		50 mm / 6 mm	THTS-1PAT10506MZ	6047588	
		75 mm / 6 mm	THTS-1PAT10756MZ	6047562	
		100 mm / 6 mm	THTS-1PAT11006MZ	6047589	
		150 mm / 6 mm	THTS-1PAT11506MZ	6047591	
		200 mm / 6 mm	THTS-1PAT12006MZ	6047592	

Type code

Output signal

P	Output signal Pt100, 4-wire
A	Transmitter 4 ... 20 mA, 2-wire

Temperature range

A	-50 ... +150 °C
B	-50 ... +250 °C

Process connection

D2	Clamp, DIN 32676, DN 10, DN 15, DN 20
D4	Clamp, DIN 32676, DN 25, DN 32, DN 40
D5	Clamp, DIN 32676, DN 50
C2	Clamp, ISO 2852, DN 12, DN 12.7, DN 17.2, DN 21.3
C3	Clamp, ISO 2852, DN 25, DN 33.7, DN 38
C5	Clamp, ISO 2852, DN 40, DN 51
T5	Tri-clamp ½", ¾"
T1	Tri-clamp 1", 1 ½"
T2	Tri-clamp 2"
VB	Varivent connector type B, DN 10, DN 15
VF	Varivent connector type F, DN 25
VN	Varivent connector type N, DN 40
51	Conical coupling, DIN 11851, DN 20, with union nut
52	Conical coupling, DIN 11851, DN 25, with union nut
53	Conical coupling, DIN 11851, DN 32, with union nut
54	Conical coupling, DIN 11851, DN 40, with union nut
55	Conical coupling, DIN 11851, DN 50 with union nut

Insertion length / diameter

0256	25 mm / 6 mm
0506	50 mm / 6 mm
0705	75 mm / 6 mm
1006	100 mm / 6 mm
1506	150 mm / 6 mm
2006	200 mm / 6 mm

THTS -	1					M	Z
--------	---	--	--	--	--	---	---



Dimensional drawings

dimensions in mm (inch)

Clamp connection

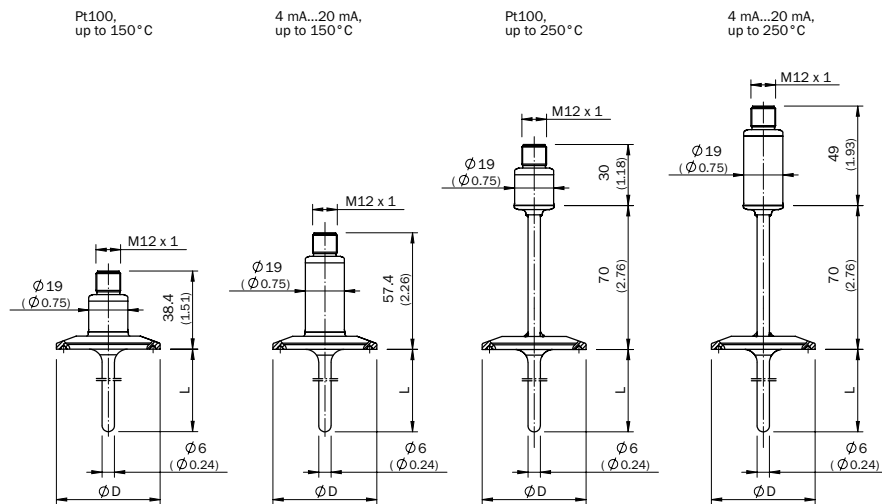

Design		Ø D
DIN 32676	DN 10 ... DN 20	34.0 (1.34)
	DN 25 ... DN 40	50.5 (1.99)
	DN 50	64.0 (2.52)
ISO 2852	DN 12 ... DN 21.3	34.0 (1.34)
	DN 25 ... DN 38	50.5 (1.99)
	DN 40, DN 51	64.0 (2.52)
Tri-Clamp	1", 1 1/2"	50.5 (1.99)
	2"	64.0 (2.52)

Tri-clamp connection 1/2", 3/4"

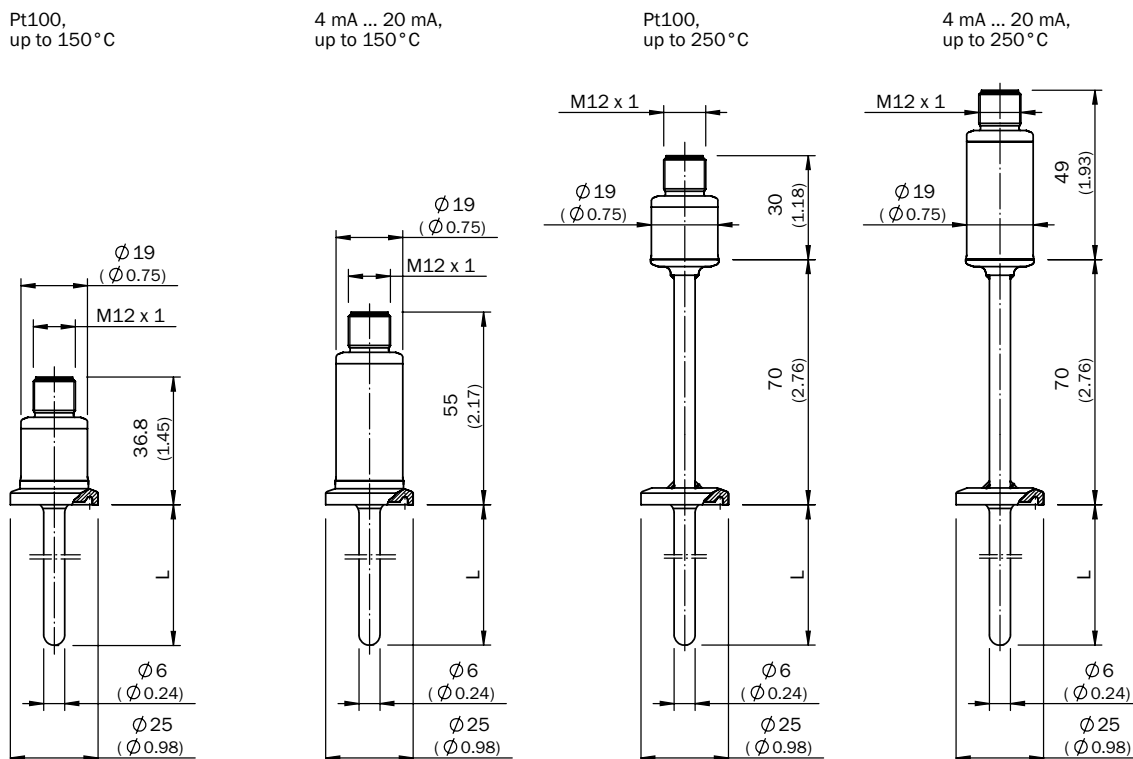

E

Varivent connector

Pt100,
up to 150°C

4 mA ... 20 mA,
up to 150°C

Pt100,
up to 250°C

4 mA ... 20 mA,
up to 250°C

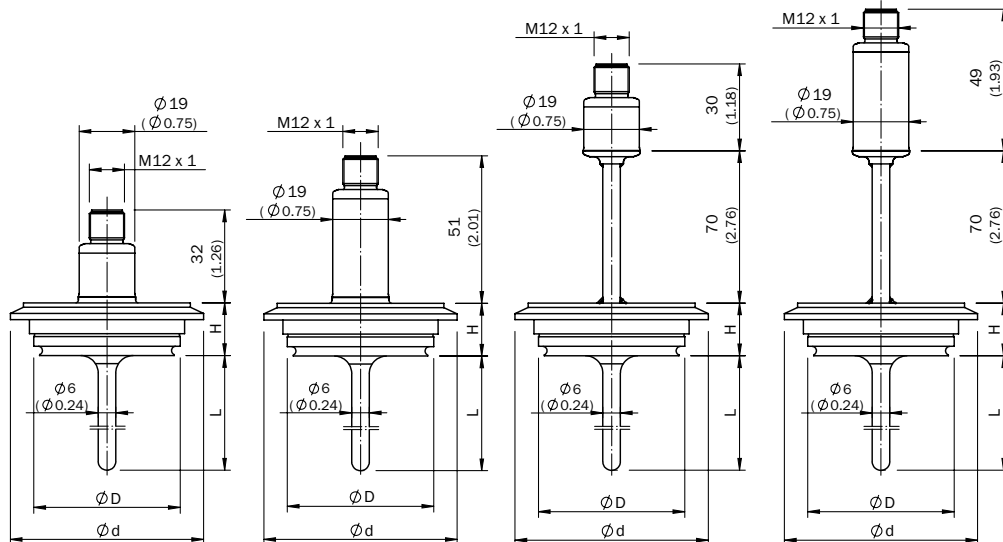

Design		Ø D	Ø d	H
VARIVENT	Form B	31.0 (1.22)	52.7 (2.07)	20.0 (0.79)
	Form F	50.0 (1.97)	66.0 (2.60)	18.0 (0.71)
	Form N	64.0 (2.52)	84.0 (3.31)	18.0 (0.71)

Conical coupling (DIN 11851) with union nut

Pt100,
up to 150°C

4 mA...20 mA,
up to 150°C

Pt100,
up to 250°C

4 mA...20 mA,
up to 250°C

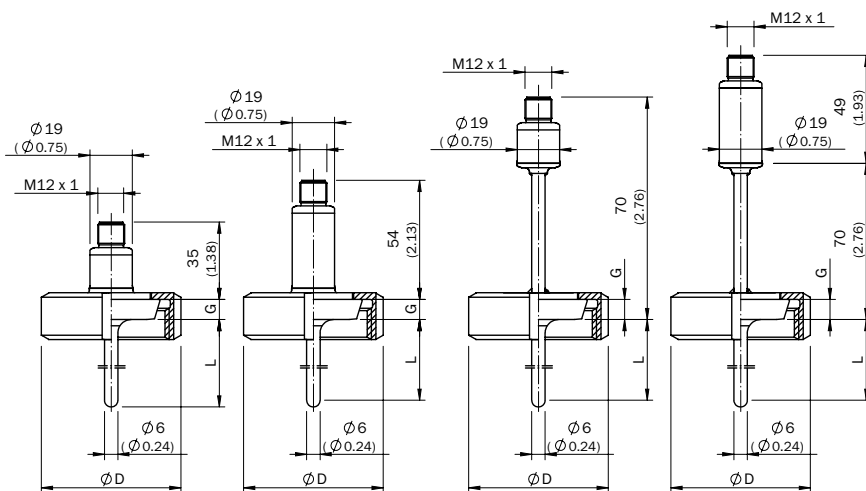





Design		Ø D	G
DIN 11851	DN 20	54.0 (2.13)	8 (0.31)
	DN 25	63.0 (2.48)	10 (0.39)
	DN 32	70.0 (2.76)	10 (0.39)
	DN 40	78.0 (3.07)	10 (0.39)
	DN 50	92.0 (3.62)	11 (0.43)



Recommended accessories

Plug connectors and cables

- **Connector type:** Female connector
- **Electrical connection:** Round connector M12 x 1, 4-pin

	Enclosure rating	Sheath material	Connector	Cable length	Model name	Part no.
	IP 67	PVC	Straight	2 m	DOL-1204-G02M	6009382
				5 m	DOL-1204-G05M	6009866
				10 m	DOL-1204-G10M	6010543
				15 m	DOL-1204-G15M	6010753
	IP 67	PVC	Angled	2 m	DOL-1204-W02M	6009383
				5 m	DOL-1204-W05M	6009867
				10 m	DOL-1204-W10M	6010541
	IP 68	PUR halogen free	Straight	2 m	DOL-1204-G02MC	6025900
				5 m	DOL-1204-G05MC	6025901
				10 m	DOL-1204-G10MC	6025902
	IP 68	PUR halogen free	Angled	2 m	DOL-1204-W02MC	6025903
				5 m	DOL-1204-W05MC	6025904
				10 m	DOL-1204-W10MC	6025905





Hygienic and flexible: Temperature sensor with protection tube







Additional information

Detailed technical data E-209

Ordering information E-210

Type code E-211

Dimensional drawings E-212

Recommended accessories E-213

Product description

The THTE temperature sensor is a hygienic-grade Pt100 resistance thermometer for applications in the food and beverage, pharmaceutical, cosmetics, and biotechnology industries. With the help of a thermowell that protrudes into the process, the sensor can be exchanged "dry". That means that the vessel remains closed and potential hygienic risks are minimized. The thermowell is available in multiple insertion lengths and is installed at the vessel by common hygienic-grade

process connections. High-grade stainless steel and a gap- and crevice-free design enable safe and clean processing. The THTE is well-suited for CIP and SIP processes. This enables safe hygienic operation in conjunction with optimized equipment availability. Besides its direct electrical connection to the Pt100 element, the THTE is available with an integrated transmitter with 4 mA ... 20 mA output signal.

At a glance

- Pt100, accuracy class A (IEC 60751)
- Measuring ranges -50 °C ... +150 °C and -50 °C ... +250 °C
- Sensor probe spring-loaded in thermowell
- Wetted parts: Corrosion-resistant stainless steel 316L/1.4435, Ra ≤ 0.8 µm
- Hygienic process connections
- Pt100 (4-wire) or 4 mA ... 20 mA (2-wire)
- Round connector M12 x 1

Your benefits

- The sensor can be exchanged without opening the process, providing high equipment availability and minimizing hygienic risks
- Safe hygienic operation: Wetted parts are made from high-grade stainless steel, hygienic-grade surface finish, and a gap- and crevice-free design
- Rugged: Connection housing is easy to clean and splash waterproof
- Quick and safe installation
- Very good long-term stability, accuracy and linearity
- Quick response time
- Optimal solutions for individual requirements due to versatile configurability

→ www.mysick.com/en/THTE

For more information, just enter the link or scan the QR code and get direct access to technical data, CAD design models, operating instructions, software, application examples and much more.



E

Detailed technical data

Features

Measuring ranges	-50 °C ... +150 °C -50 °C ... +250 °C
Sensor element	Pt100
Signal outputs and maximum ohmic load R_A	Pt100, 4-wire 4 mA ... 20 mA, 2-wire ($R_A \leq (L^+ - 10 \text{ V}) / 0.023 \text{ A [Ohm]}$)

Performance

Accuracy of sensor element	Class A according IEC 60751
Accuracy of optional transmitter	$\leq \pm 0.2 \%$ of span
Linearity of optional transmitter	$\leq \pm 0.1 \%$ of span
Response time ¹⁾	
Response time t_{50}	$\leq 4.7 \text{ s}$
Response time t_{90}	$\leq 12.2 \text{ s}$

¹⁾ Depending on sensor configuration, according to IEC 60751.

Mechanics/electronics

Process connection	See type code
Insertion lengths/diameter of probe	25 mm / 6 mm 50 mm / 6 mm 75 mm / 6 mm 100 mm / 6 mm 150 mm / 6 mm 200 mm / 6 mm
Wetted parts	Stainless steel 1.4435 (316L), $R_a \leq 0.8 \mu\text{m}$
Pressure resistance ¹⁾	16 bar with clamp connections according to DIN 32676, ISO 2852 and tri-clamp 40 bar with conical coupling (DIN 11851) DN 20, DN 25, DN 32 and DN 40 with union nut 25 bar with conical coupling (DIN 11851) DN 50 with union nut 25 bar with Varivent connector form B, DN 10, DN 15 25 bar with Varivent connector form F 16 bar with Varivent connector form N
Housing material	Stainless steel 1.4571 (316Ti)
Enclosure rating of connection housing ²⁾	IP 68 and IP 69K
Electrical connection	Round connector M12 x 1, 4-pin
Measuring current	0.3 mA ... 1 mA, for variant with output signal Pt100
Supply voltage	10 V DC ... 35 V DC for variant with transmitter 4 mA ... 20 mA
Maximum current consumption	Ca. 30 mA for variant with transmitter 4 mA ... 20 mA
Electrical safety	Protection class: III Dielectric strength: 500 V AC Reverse polarity protection of variant with transmitter 4 mA ... 20 mA: L ⁺ towards M
CE-conformity	2004/108/EC, EN 61326-2-3
RoHS certificate	✓
Initialization time	< 10 ms

¹⁾ Pressure resistance at room temperature.

²⁾ Enclosure rating IP 68 per IEC 60529 and IP 69K per DIN 40 050-1. The enclosure rating classes specified only apply while the pressure transmitter is connected with female connectors that provide the corresponding enclosure rating.

Ambient data

Ambient temperature	-40 °C ... +85 °C
Storage and transport temperature	-40 °C ... +85 °C
Shock resistance	According to IEC 60751
Vibration resistance according to IEC 60751	3 g
Relative humidity	≤ 95 %

Ordering information

The part numbers below show a selection of our common configurations and represent only a portion of the product portfolio. The type code on page E-211 indicates all possible configurations that can be ordered.

- **Measuring range:** -50 °C ... +150 °C
- **Electrical connection/enclosure rating of connection housing:** Round connector M12 x 1, 4-pin / IP 68 and IP 69K

Output signal	Process connection	Insertion length/diameter of probe	Model name	Part no.		
4 mA ... 20 mA, 2-wire	Tri-clamp 1", 1 ½"	25 mm / 6 mm	THTE-1AAT10256MZ	6047629		
		50 mm / 6 mm	THTE-1AAT10506MZ	6047630		
		75 mm / 6 mm	THTE-1AAT10756MZ	6047631		
		100 mm / 6 mm	THTE-1AAT11006MZ	6047632		
		150 mm / 6 mm	THTE-1AAT11506MZ	6047633		
		200 mm / 6 mm	THTE-1AAT12006MZ	6047634		
	Conical coupling (DIN 11851) DN 40 with union nut	25 mm / 6 mm	THTE-1AA540256MZ	6047635		
		50 mm / 6 mm	THTE-1AA540506MZ	6047636		
		75 mm / 6 mm	THTE-1AA540756MZ	6047637		
		100 mm / 6 mm	THTE-1AA541006MZ	6047639		
		150 mm / 6 mm	THTE-1AA541506MZ	6047640		
		200 mm / 6 mm	THTE-1AA542006MZ	6047641		
		Pt100, 4-wire	Tri-clamp 1", 1 ½"	25 mm / 6 mm	THTE-1PAT10256MZ	6047615
				50 mm / 6 mm	THTE-1PAT10506MZ	6047616
75 mm / 6 mm	THTE-1PAT10756MZ			6047618		
100 mm / 6 mm	THTE-1PAT11006MZ			6047563		
150 mm / 6 mm	THTE-1PAT11506MZ			6047620		
200 mm / 6 mm	THTE-1PAT12006MZ			6047621		
Conical coupling (DIN 11851) DN 40 with union nut	25 mm / 6 mm		THTE-1PA540256MZ	6047622		
	50 mm / 6 mm		THTE-1PA540506MZ	6047623		
	75 mm / 6 mm		THTE-1PA540756MZ	6047625		
	100 mm / 6 mm		THTE-1PA541006MZ	6047626		
	150 mm / 6 mm		THTE-1PA541506MZ	6047627		
	200 mm / 6 mm		THTE-1PA542006MZ	6047628		



Dimensional drawings

dimensions in mm (inch)

Clamp connection

Complete assembly

Protection tube with process connection

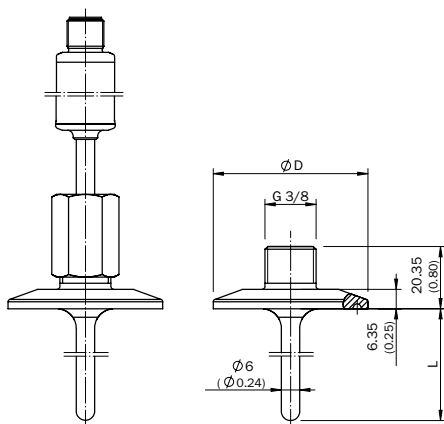

Design		Ø D
DIN 32676	DN 10 ... DN 20	34.0 (1.34)
	DN 25 ... DN 40	50.5 (1.99)
	DN 50	64.0 (2.52)
ISO 2852	DN 12 ... DN 21.3	34.0 (1.34)
	DN 25 ... DN 38	50.5 (1.99)
	DN 40, DN 51	64.0 (2.52)
Tri-Clamp	1", 1 1/2"	50.5 (1.99)
	2"	64.0 (2.52)

Tri-clamp connection 1/2", 3/4"

Complete assembly

Protection tube with process connection

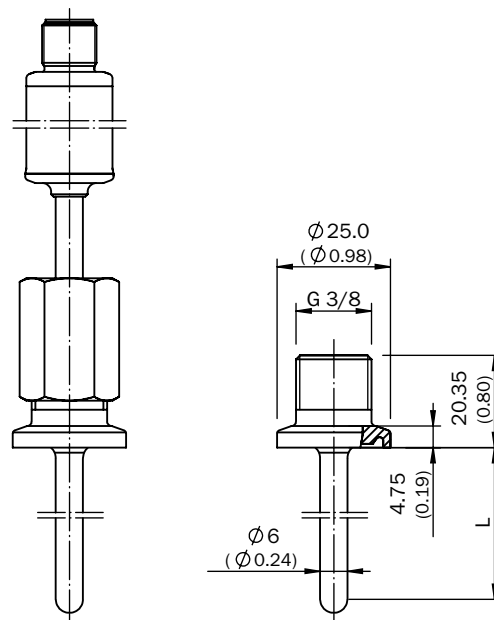

Varivent connector

Complete assembly

Protection tube with process connection

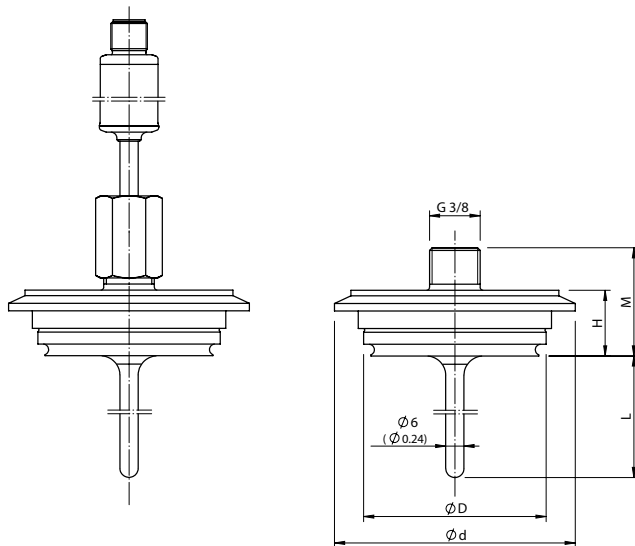

Design		Ø D	Ø d	M	H
VARIVENT	Form B	31.0 (1.22)	52.7 (2.07)	34.0 (1.34)	20.0 (0.79)
	Form F	50.0 (1.97)	66.0 (2.60)	32.0 (1.26)	18.0 (0.71)
	Form N	64.0 (2.52)	84.0 (3.31)	32.0 (1.26)	18.0 (0.71)

Conical coupling (DIN 11851) with union nut

Complete assembly

Protection tube with process connection

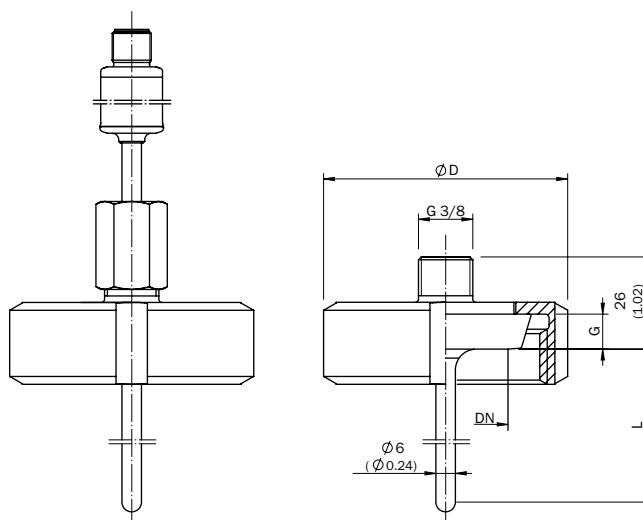

Design		Ø D	G
DIN 11851	DN 20	54.0 (2.13)	8.0 (0.31)
	DN 25	63.0 (2.48)	10.0 (0.39)
	DN 32	70.0 (2.76)	10.0 (0.39)
	DN 40	78.0 (3.07)	10.0 (0.39)
	DN 50	92.0 (3.62)	11.0 (0.43)

E

Measuring probe without protection tube

Pt100

4 mA ... 20 mA

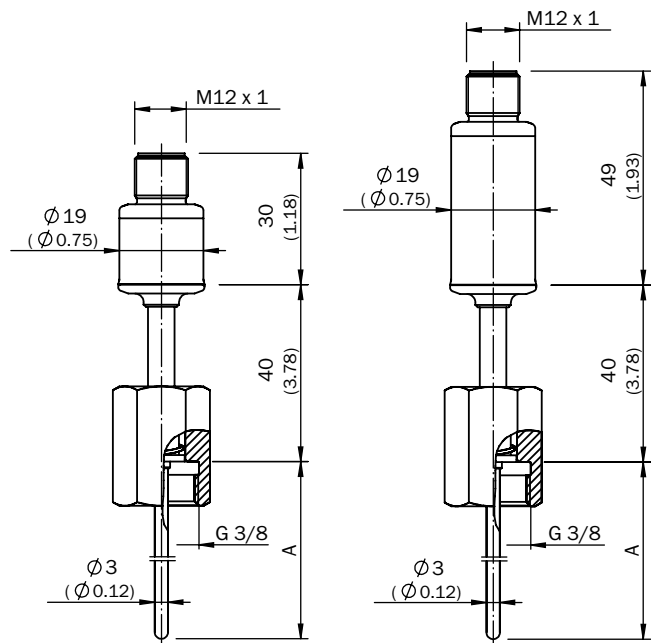

Recommended accessories

Plug connectors and cables

- **Connector type:** Female connector
- **Electrical connection:** Round connector M12 x 1, 4-pin

	Enclosure rating	Sheath material	Connector	Cable length	Model name	Part no.
	IP 67	PVC	Straight	2 m	DOL-1204-G02M	6009382
				5 m	DOL-1204-G05M	6009866
				10 m	DOL-1204-G10M	6010543
				15 m	DOL-1204-G15M	6010753
	IP 67	PVC	Angled	2 m	DOL-1204-W02M	6009383
				5 m	DOL-1204-W05M	6009867
				10 m	DOL-1204-W10M	6010541
	IP 68	PUR halogen free	Straight	2 m	DOL-1204-G02MC	6025900
				5 m	DOL-1204-G05MC	6025901
				10 m	DOL-1204-G10MC	6025902
			Angled	2 m	DOL-1204-W02MC	6025903
				5 m	DOL-1204-W05MC	6025904
				10 m	DOL-1204-W10MC	6025905





Perfect fit: Hygienic temperature measurement in pipes







Additional information

Detailed technical data E-215

Ordering information E-216

Type code E-216

Dimensional drawings E-217

Recommended accessories E-219

Product description

Designed as an in-line thermometer, the THTL temperature sensor is the preferred solution for hygienic temperature measurement in pipes. Typical applications are in the food and beverage, pharmaceutical, cosmetics and biotechnology industries. The THTL has an in-line housing that is fitted into the pipe. The Pt100 sensor is located inside a thermowell that is placed in the medium flow. It can easily and quickly be replaced for maintenance or calibration. This ensures safe hygienic operation.

The design of the wetted parts made from corrosion-resistant stainless steel complies with hygienic standards and enables quick response times. The THTL is well-suited for CIP and SIP processes. This enables safe hygienic operation in conjunction with optimized equipment availability. Besides its direct electrical connection to the Pt100 element, the THTL is available with an integrated transmitter with 4 mA ... 20 mA output signal.

At a glance

- Pt100, accuracy class A (IEC 60751)
- Measuring ranges -50 °C ... +150 °C and -50 °C ... +250 °C
- In-line housing for orbital welding in pipe
- Sensor probe spring-loaded in thermowell
- Wetted parts: Corrosion-resistant stainless steel 316L/1.4435, Ra ≤ 0.8 µm
- Pt100 (4-wire) or 4 mA ... 20 mA (2-wire)
- Round connector M12 x 1

Your benefits

- Engineered for installation in a pipe, the integrated design provides the optimal solution to this type of measurement
- The sensor can be exchanged without opening the process, providing high equipment availability and minimizing hygienic risks
- Safe hygienic operation: Wetted parts are made from high-grade stainless steel, hygienic-grade surface finish, and a design with minimum of dead space
- Rugged: Connection housing is easy to clean and splash waterproof
- Very good long-term stability, accuracy and linearity
- Quick response time
- Optimal solutions for individual requirements due to versatile configurability

→ www.mysick.com/en/THTL

For more information, just enter the link or scan the QR code and get direct access to technical data, CAD design models, operating instructions, software, application examples and much more.



E

Detailed technical data

Features

Measuring ranges	-50 °C ... +150 °C -50 °C ... +250 °C
Sensor element	Pt100
Signal outputs and maximum ohmic load R_A	Pt100, 4-wire 4 mA ... 20 mA, 2-wire ($R_A \leq (L^+ - 10 \text{ V}) / 0.023 \text{ A [Ohm]}$)

Performance

Accuracy of sensor element	Class A according IEC 60751
Accuracy of optional transmitter	$\leq \pm 0.2 \%$ of span
Linearity of optional transmitter	$\leq \pm 0.1 \%$ of span
Response time ¹⁾	
Response time t_{50}	$\leq 3.2 \text{ s}$
Response time t_{90}	$\leq 7.3 \text{ s}$

¹⁾ Depending on sensor configuration, according to IEC 60751.

Mechanics/electronics

Process connection	See type code
Nominal widths	DN 17.2 DN 21.3 DN 26.9 DN 42.4
Wetted parts	Stainless steel 1.4435 (316L), $R_a \leq 0.8 \mu\text{m}$
Pressure resistance ¹⁾	25 bar
Housing material	Stainless steel 1.4571 (316Ti)
Enclosure rating of connection housing ²⁾	IP 68 and IP 69K
Electrical connection	Round connector M12 x 1, 4-pin
Measuring current	0.3 mA ... 1 mA, for variant with output signal Pt100
Supply voltage	10 V DC ... 35 V DC for variant with transmitter 4 mA ... 20 mA
Maximum current consumption	Ca. 30 mA for variant with transmitter 4 mA ... 20 mA
Electrical safety	Protection class: III Dielectric strength: 500 V AC Reverse polarity protection of variant with transmitter 4 mA ... 20 mA: L ⁺ towards M
CE-conformity	2004/108/EC, EN 61326-2-3
RoHS certificate	✓
Initialization time	< 10 ms

¹⁾ Pressure resistance at room temperature.

²⁾ Enclosure rating IP 68 per IEC 60529 and IP 69K per DIN 40 050-1. The enclosure rating classes specified only apply while the pressure transmitter is connected with female connectors that provide the corresponding enclosure rating.

Ambient data

Ambient temperature	-40 °C ... +85 °C
Storage and transport temperature	-40 °C ... +85 °C
Shock resistance	According to IEC 60751
Vibration resistance according to IEC 60751	3 g
Relative humidity	$\leq 95 \%$

Dimensional drawings

dimensions in mm (inch)

Measuring probe without protection tube

Pt100

4 mA ... 20 mA

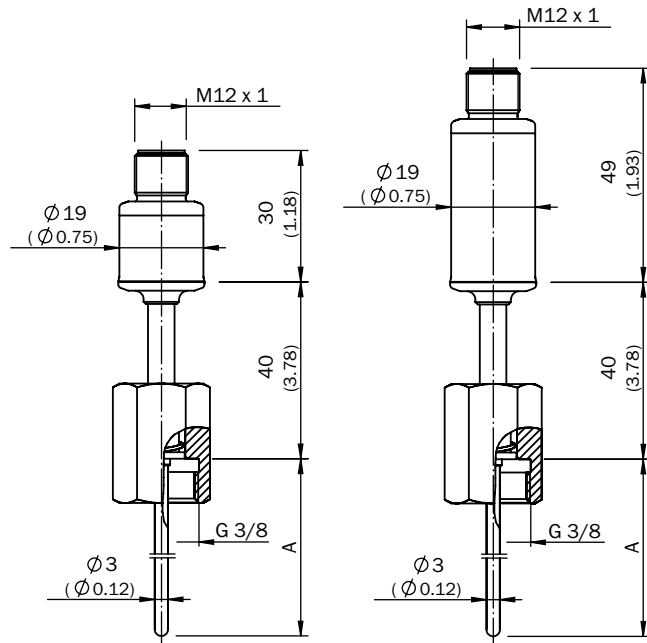

Process connection: Straight pipe

Complete assembly

Protection tube with process connection

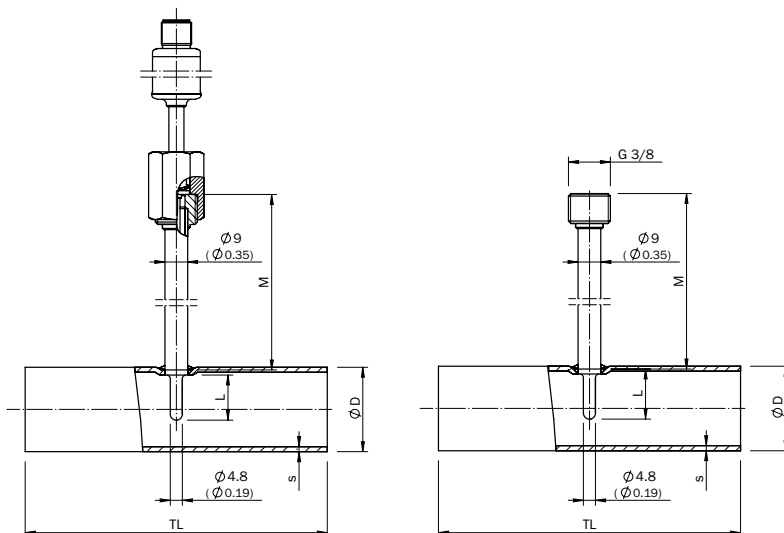

Design		Ø D	s	TL	L	M
Straight pipe	NW 17.2	17.2 (0.68)	1.6 (0.06)	68.0 (2.68)	9.0 (0.35)	48.0 (1.89)
	NW 21.3	21.3 (0.84)	1.6 (0.06)	72.0 (2.83)	11.0 (0.43)	46.0 (1.81)
	NW 26.9	26.9 (1.06)	1.6 (0.06)	110.0 (4.33)	11.0 (0.43)	46.0 (1.81)
	NW 42.4	42.4 (1.67)	2.0 (0.08)	130.0 (5.12)	18.0 (0.71)	39.0 (1.54)

Process connection: Angled pipe

Complete assembly

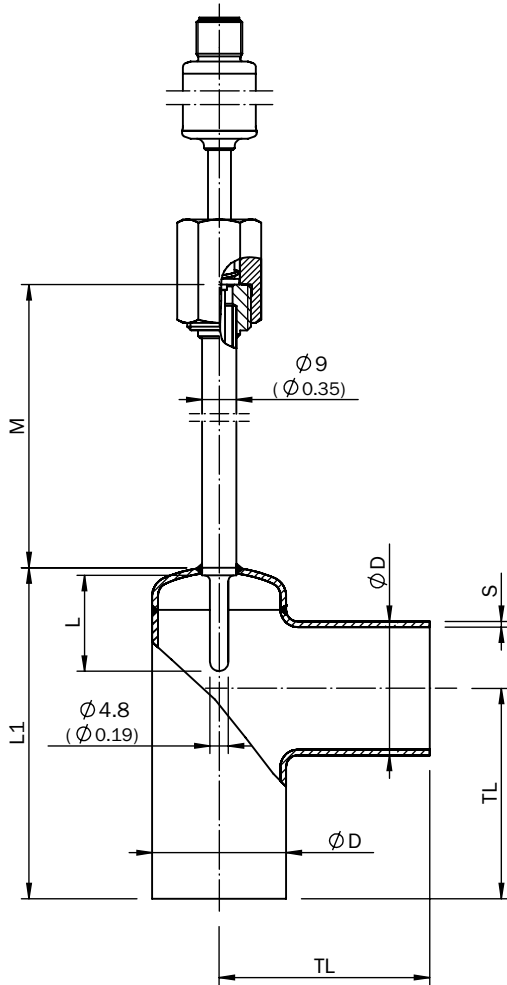

Protection tube with process connection

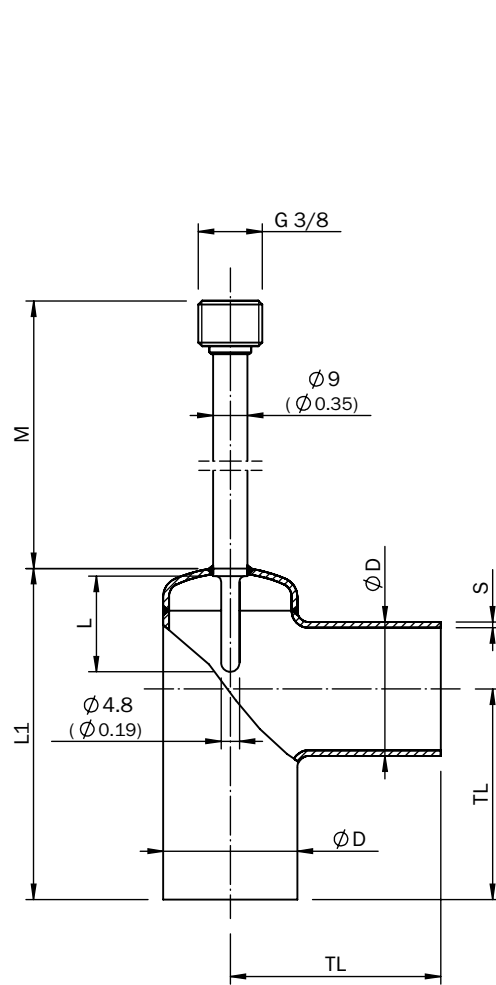





Design		Ø D	s	TL	L1	L	M
Angled pipe	NW 17.2	17.2 (0.68)	1.6 (0.63)	34.0 (13.39)	55.0 (21.65)	16.0 (6.30)	41.0 (16.14)
	NW 21.3	21.3 (0.84)	1.6 (0.63)	36.0 (14.17)	58.0 (22.83)	18.0 (7.09)	39.0 (15.35)
	NW 26.9	26.9 (1.06)	1.6 (0.63)	55.0 (21.65)	81.0 (31.89)	30.0 (11.81)	27.0 (10.63)
	NW 42.4	42.4 (1.17)	2.0 (0.79)	65.0 (25.59)	102.0 (40.16)	30.0 (11.81)	27.0 (10.63)



Recommended accessories

Plug connectors and cables

- **Connector type:** Female connector
- **Electrical connection:** Round connector M12 x 1, 4-pin

	Enclosure rating	Sheath material	Connector	Cable length	Model name	Part no.
	IP 67	PVC	Straight	2 m	DOL-1204-G02M	6009382
				5 m	DOL-1204-G05M	6009866
				10 m	DOL-1204-G10M	6010543
				15 m	DOL-1204-G15M	6010753
			Angled	2 m	DOL-1204-W02M	6009383
				5 m	DOL-1204-W05M	6009867
				10 m	DOL-1204-W10M	6010541
			IP 68	PUR halogen free	Straight	2 m
	5 m	DOL-1204-G05MC				6025901
	10 m	DOL-1204-G10MC				6025902
	Angled	2 m			DOL-1204-W02MC	6025903
		5 m			DOL-1204-W05MC	6025904
		10 m			DOL-1204-W10MC	6025905



Information compact: Important information about SICK sensor solutions

From A (Absolute pressure measurement) to W (WGH): The following pages contain explanations of key specialist terminology in a compact, easy-to-read format. Definitions of all key terms related to innovations and sensor solutions by SICK can be found here.

Tables for temperature, level and pressure measurement round out the chapter and make the appendix a valuable reference.



Appendix

Glossary	F-222
Technologies and topics	F-228
Example of use.	F-228
Explosion protection according to ATEX	F-230
Materials	F-232
Pressure and temperature units	F-233
Dielectric constants	F-234

Glossary

0 - 9

3-A

3-A (3-A Sanitary Standards, Inc.) based in McLean, Virginia, USA, is an association for the drafting of directives for the hygienic processing and packaging of dairy products and other foodstuffs. 3-A issues certificates for machine components that comply with their standards. The EHEDG has a comparable function for the European market.

A

Absolute pressure measurement

The absolute pressure measurement delivers the pressure based on a concrete reference, the vacuum. In this way, the influence of weather-related environmental pressure fluctuations or geographical altitude changes on pressure measurement is eliminated.

Accuracy classes of temperature measurement / tolerance

The maximum permissible temperature deviation in °C of a platinum resistance thermometer sensor from the values defined in IEC 60751 is referred to as a tolerance. The tolerances are divided into accuracy classes. The data applies to thermometers with any nominal resistance R_0 .

Class	Scope		
	Wire-wound resistors	Film resistors	Tolerance (°C)
AA	-50 to 250 °C	0 to 150 °C	$\pm (0.1 + 0.0017 \times T)$
A	-100 to 450 °C	-30 to 300 °C	$\pm (0.15 + 0.002 \times T)$
B	-196 to 600 °C	-50 to 500 °C	$\pm (0.3 + 0.005 \times T)$
C	-196 to 600 °C	-50 to 600 °C	$\pm (0.6 + 0.01 \times T)$

|T|: Absolute value of temperature in °C, regardless of algebraic sign

For SICK temperature sensors, Pt100 or Pt1000 film resistors of accuracy classes A and B are used.

ATEX

ATEX (Atmosphère explosible) describes the directives of the European Union pertaining to explosion protection, including, among others, Directive 94/9/EC.

C

Cable

Cables have various properties depending on the sheath materials used:

FEP cable

- Fluorinated ethylene propylene
- Highly resistant

PUR cable

- Oil-resistant
- Not resistant to hydrolysis

PVC cable

- Not suitable for long-term use in surroundings containing oil
- Not resistant to ozone and UV light

Movement of cables at temperatures below -5 °C must be prevented to prevent breaking.

Compound pressure measuring range

When a typical gauge pressure measurement measures the excess pressure of a container and the pressure transmitter delivers its null signal when measuring environmental pressure, the measuring range of a pressure transmitter has a typical plus-minus measuring range from -1 bar to the respective maximum value (e.g. -1 bar to +3 bar). The compound measuring ranges are, therefore, gauge pressure measuring ranges with offset zero point.

Creep flow suppression (minimum flow)

Flow sensors use creep flow suppression to zero flow generated by convection despite a closed valve. The threshold for creep flow suppression can be adjusted based on the applications requirements. If flow falls below the threshold set, the signal outputs and display are set to zero.

D

DTM

A DTM (Device Type Manager) encompasses all functions, the structure, the parameters and the graphic user interface for a particular field device or device family. It is installed as a program on a PC, but can only be started from a framework application.

E

EHEDG

EHEDG (European Hygienic Engineering & Design Group) compiles directives for the hygienic processing and packaging of foodstuffs and develops tests for the checking of hygienic standards. 3-A Sanitary Standards undertakes a comparable function for directives for the American market.

Electronic pressure switch

A device is described as a pressure switch if it possesses switching outputs which are activated when defined pressure values (switching points) are activated. An electronic pressure switch has transistor outputs (PNP / NPN). It is normally operated via PC controller or programmable logic controller (PLC).

Enclosure ratings

The enclosure rating indicates the degree of protection of a machine or sensor against contact and penetration by impurities and water. The enclosure ratings begin with the letters IP, followed by the first digit, which indicates the degree of protection provided against ingress of solid objects. The second digit shows the enclosure's protection against the ingress of water. The higher the number, the greater the protection indicated by that digit. Enclosure ratings of IP 65 and higher have established themselves as the standard for industrial applications.

F

FDA

The FDA (Federal Food and Drug Administration) based in Silver Spring, Maryland, USA, is the American supervisory body for drugs and foodstuffs. Among other responsibilities, it decrees the regulations on the use of substances in hygienic environments.

Filling liquids for pressure sensors

To decouple the process medium from the measuring membrane, stainless steel membranes are used, which come into direct contact with the medium. In the case of piezoresistive measurement cells, it is therefore necessary to protect the sensitive measuring membrane from the medium. The pressure transfer from the upstream stainless steel membrane to the measuring membrane of the measurement cell occurs hydraulically using the so-called filling liquid. This is also referred to as the pressure transmission liquid. Using filling liquids, pressure transmitters and switches are also made with (stainless steel) flush-mounted membranes. The stainless steel membranes are then usually designed cavity free to address applications destined for dirty media or applications in sterile process engineering. For hygienic applications in the food industry, strict standards are imposed on filling liquids. For such applications, SICK generally uses filling liquids, which meet the standards of the US Food and Drug Association (FDA).

FKM / FPM

FKM (according to ISO) or the equivalent FPM (according to DIN) describes fluororubber variations, which are distinguished by their durability and temperature stability. They are often used as sealing material, the most well-known of which is "Viton".

Flow profiles

Laminar flow is the movement of liquids and gases, when there is no turbulence (swirling / cross flows). The fluid flows in layers that do not mix. In this case, the flow is usually steady (flow speed is constant).

Turbulent flow is the movement of liquids and gases, when there is turbulence on all size scales. This flow pattern is characterized by mostly three-dimensional, seemingly random, unsteady movements of the fluid particles.

Flush-mounted membrane

Hygienic applications require cavity-free construction, so that no residual media can adhere during operation and the pressure transmitter can be cleaned easily. This requires flush-mounted membranes. SICK's pressure transmitters and switches with a flush-mounted membrane are fitted with hermetically-sealed stainless steel membranes, which are also welded. Therefore, the membrane does not need to be sealed against the housing. See also Filling liquids.

G

Gauge pressure

Gauge pressure measurement is when the pressure of a container is measured relatively to the environment. Thus, the gauge pressure measurement indicates the excess pressure that exists in the container. The gauge pressure measurement represents the most common type of pressure measurement in engineering.

H

HACCP

HACCP (Hazard Analysis and Critical Control Point) is an FMEA-methodology-related concept for the management and documentation of the processes of hygienic processing and the relevant distribution of foodstuffs. Various laws and regulations stipulate the compulsory use of the HACCP concept, including the German regulation on the hygiene of foodstuffs and the European Regulation 852/2004.

I

Inlet / outlet path

This describes the straight lengths of tube upstream and downstream of the flow meter so that good flow and measurement conditions can be established.

IO-Link

 **IO-Link** IO-Link is a manufacturer-comprehensive, cost-effective, point-to-point connection for communication-capable sensors and actuators below the fieldbus level. This communication

technology and its features allow machines and systems to be operated much more effectively:

- Reduction in machine downtimes and changeover times
- Easy parameter setting and parameter storage
- Improved process quality through continuous monitoring of process parameters
- Reduced maintenance costs through proactive, problem-oriented diagnostics
- Investment security through open standard transfer of parameters (e.g. switching points, reset points, etc.) from PLC or IPC direct to the sensor. Thus format or product changes can be handled within a few milliseconds even with inaccessible sensors.
- Reduced downtimes through detailed diagnostics ("see what the sensor sees").

L

Level probes

Level probes are immersible pressure transmitters used to measure levels in liquid media. Liquid columns generate the so-called hydrostatic pressure in a given water depth, which is measured precisely using level probes. As a rule of thumb: 10 m water depth corresponds to the pressure of ca. 1 bar. The density and therefore, the type of liquid directly influences the hydrostatic pressure and must, therefore, be known for conversion of the measured pressure to the correct filling level. Since the density of the liquid is also dependent upon temperature, SICK offers optional temperature measurement with its LFH level probe.

M

Measurement accuracy / non-linearity

Measurement accuracy relates to the maximum deviation of the actual output signal over the ideal characteristic curve. This includes deviations from the line (non-linearity), zero point and final value error and hysteresis. Measurement accuracy is given in % of the span.

Medium / empty pipe detection

This function is used to detect partially filled or empty measuring tubes. An additional switching output indicates that the flow signals differ or a measurement is no longer possible. Apart from an unfavorable installation location, triggers can be degassing media or varying process pressures.

N

NBR

NBR (Nitrile Butadiene Rubber) is a material made of synthetic rubber. It offers good temperature flexibility and is resistant to swelling in oils, grease and fuels. That is why NBR

is often used as a sealing substance.

O

Optical level measurement

A variety of measurement principles can be used for optical level control. The most common are limit switches that make use of the different refractive indices of air and liquid and thus generate a switching signal via the changed reflection of the light beam at the transition to the medium to be measured. For continuous measurement, laser sensors can be used. In this case, the transit time of a laser pulse from its emission to the return of its reflection is determined and from that, the distance of the surface of the medium from the sensor is calculated.

P

PBT

PBT (Polybutylene terephthalate) is a plastic, which is often used as a housing material, owing to its properties in fluid-sensor technology. PBT exhibits a comparably high chemical resistance against aliphatic compounds and arenes, as well as high temperature stability.

Pressure

Pressure is the ratio of perpendicular force on a surface relative to the size of this area. The SI derived unit of pressure is pascal = 1 Pa = 1 N/m². Derived from this is the unit bar = 0.1 MPa in engineering.

Pressure port / pressure peak damping element

The process medium is introduced lengthwise through a bore hole through the process connection to the membrane of the measurement cell. This bore hole is also described as a pressure port. In the case of hydraulic applications, pressure peaks can arise as a result of switching valve. In order to dampen these pressure peaks, SICK offers pressure sensors and switches with reduced internal diameters of the pressure port. Thus, the pressure peak damping element becomes part of the device and, in principal, cannot be lost, which, with screw-on damping elements, can lead to annoying unforeseen incidents.

Pressure loss

Pressure loss is caused by the friction of liquids and gases in pipelines. This also applies to inline flow meters whose internal structure could reduce pressure.

Pressure measurement principles

SICK uses piezoresistive or thin metal film sensors for its pressure transmitter sensors, switches and level probes, depending on the measuring range.

Pressure measuring ranges / excessive pressure / burst pressure

The pressure-measuring ranges relate to the specific pressure area in which the electrical output signal responds to the pressure. When the upper or lower end of measuring range is exceeded or falls short respectively, the output signal generally deviates from the specified characteristic curve. As soon as the pressure returns to within the pressure-measuring ranges, the device once again supplies the specified output signal. Should the sensor become pressurized above the so-called excessive pressure, however, irreparable damage occurs. Should the so-called bursting pressure be exceeded still further, the membrane is damaged.

Process connection

The mechanical connection between the container and the sensor is referred to as the process connection. Here, there are numerous regionally-different threads or flanges to choose from. In Europe, type G pipe threads with various diameters are mainly used. A widely-used thread in pressure measurement is the so-called manometer connection according to EN 837. The connection is based on a G-thread and on its front head a spigot holds the seal in position. In the USA, type NPT (National Pipe Thread) are primarily used. The process connections are available with either internal or external threads.

For applications in food and beverage technology, hygienic flange and clamp connections are used, which are distinguished by a largely cavity-free geometry, e.g. the common tri-clamp connection or the conical coupling according to DIN 11851.

Protection class

Electrical equipment is classified in relation to existing safety measures for prevention of electric shocks. Protection classes are defined in DIN EN 61140. There are four protection classes ranging from "Basic insulation" (Class 0) to "Safety extra-low voltage, double insulation, safety transformer" (Class III).



Protection class 1



Protection class 2



Protection class 3

PTFE

PTFE (polytetrafluoroethylene), colloquially mainly known as Teflon, is a fluorocarbon polymer with particularly high chemical resistance, especially against bases, alcohols, ketones, benzines and oils. At the same time, the substance has a high temperature stability. PTFE is used as a sealing material and as protection against chemically-aggressive media, among other uses.

Pulse output

The pulse output of a flow meter is used to count the flow rate. A rate is assigned to the pulse via the pulse value. A higher-order system counts the pulse and can then interpret a flow rate using the pulse value.

Pulse value

The corresponding flow rate is assigned to each pulse, e.g. 1 liter per pulse.

R

Rated temperature range

The rated temperature range indicates the temperature range in which the performance data specified in the data sheet are valid.

Resistance thermometer

In industrial instrumentation, resistance thermometers are common for temperature measurement. The devices are used to determine the media temperature by measuring the temperature-dependent electrical resistance of a platinum resistor. Standardized platinum resistors are normally used, whose resistance at a temperature of 0 °C is 100 Ω or 1000 Ω (Pt100 or Pt1000). The properties of the platinum resistance thermometers are defined in IEC 60751. The dependence of the platinum resistor on temperature is defined by:

$$R(T) = R_0 (1 + A T + B T^2 + C (T - 100 \text{ °C}) T^3)$$

in the temperature range -200 °C to 0 °C

$$R(T) = R_0 (1 + A T + B T^2)$$

in the temperature range 0 °C to 850 °C

Where

$$A = 3.9083 \times 10^{-3} \text{ °C}^{-1}$$

$$B = -5.775 \times 10^{-7} \text{ °C}^{-2}$$

$$C = -4.183 \times 10^{-12} \text{ °C}^{-3}$$

R_0 is the resistance in Ω at 0 °C

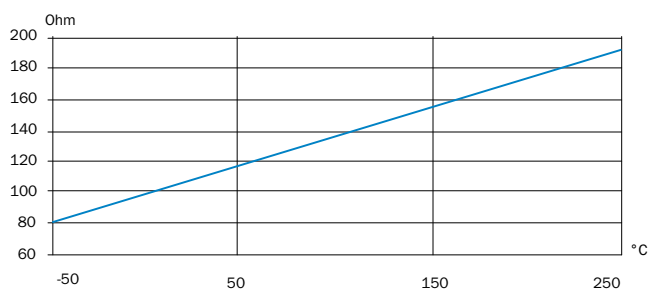

Fig. Characteristic curve of a Pt100 resistance thermometer

According to IEC 60751, resistance thermometers are to be designed with 3-wire and 4-wire circuit. Thus, the effect of the finite resistance of the connection cable on the resistance measurement of the platinum thermometer sensor is compensated or excluded.

Temperature transmitters are also often used with analog output signal 4 mA to 20 mA or 0 V to 10 V. There is usually a 2-wire or 3-wire connection between the transmitter and the controller.

T	+1	+2	+3	+4	+5	+6	+7	+8	+9	
-50	80.31	80.70	81.10	81.50	81.89	82.29	82.69	83.08	83.48	83.87
-40	84.27	84.67	85.06	85.46	85.85	86.25	86.64	87.04	87.43	87.83
-30	88.22	88.62	89.01	89.40	89.80	90.19	90.59	90.98	91.37	91.77
-20	92.16	92.55	92.95	93.34	93.73	94.12	94.52	94.91	95.30	95.69
-10	96.09	96.48	96.87	97.26	97.65	98.04	98.44	98.83	99.22	99.61
0	100.00	100.39	100.78	101.17	101.56	101.95	102.34	102.73	103.12	103.51
10	103.90	104.29	104.68	105.07	105.46	105.85	106.24	106.63	107.02	107.40
20	107.79	108.18	108.57	108.96	109.35	109.73	110.12	110.51	110.90	111.29
30	111.67	112.06	112.45	112.83	113.22	113.61	114.00	114.38	114.77	115.15
40	115.54	115.93	116.31	116.70	117.08	117.47	117.86	118.24	118.63	119.01
50	119.40	119.78	120.17	120.55	120.94	121.32	121.71	122.09	122.47	122.86
60	123.24	123.63	124.01	124.39	124.78	125.16	125.54	125.93	126.31	126.69
70	127.08	127.46	127.84	128.22	128.61	128.99	129.37	129.75	130.13	130.52
80	130.90	131.28	131.66	132.04	132.42	132.80	133.18	133.57	133.95	134.33
90	134.71	135.09	135.47	135.85	136.23	136.61	136.99	137.37	137.75	138.13
100	138.51	138.88	139.26	139.64	140.02	140.40	140.78	141.16	141.54	141.91
110	142.29	142.67	143.05	143.43	143.80	144.18	144.56	144.94	145.31	145.69
120	146.07	146.44	146.82	147.20	147.57	147.95	148.33	148.70	149.08	149.46
130	149.83	150.21	150.58	150.96	151.33	151.71	152.08	152.46	152.83	153.21
140	153.58	153.96	154.33	154.71	155.08	155.46	155.83	156.20	156.58	156.95
150	157.33	157.70	158.07	158.45	158.82	159.19	159.56	159.94	160.31	160.68
160	161.05	161.43	161.80	162.17	162.54	162.91	163.29	163.66	164.03	164.40
170	164.77	165.14	165.51	165.89	166.26	166.63	167.00	167.37	167.74	168.11
180	168.48	168.85	169.22	169.59	169.96	170.33	170.70	171.07	171.43	171.80
190	172.17	172.54	172.91	173.28	173.65	174.02	174.38	174.75	175.12	175.49
200	175.86	176.22	176.59	176.96	177.33	177.69	178.06	178.43	178.79	179.16
210	179.53	179.89	180.26	180.63	180.99	181.36	181.72	182.09	182.46	182.82
220	183.19	183.55	183.92	184.28	184.65	185.01	185.38	185.74	186.11	186.47
230	186.84	187.20	187.56	187.93	188.29	188.66	189.02	189.38	189.75	190.11
240	190.47	190.84	191.20	191.56	191.92	192.29	192.65	193.01	193.37	193.74
250	194.10	194.46	194.82	195.18	195.55	195.91	196.27	196.63	196.99	197.35

Table: Resistance values for Pt100 thermometers according to IEC 60751.
At a temperature of $T = 23\text{ }^{\circ}\text{C}$, for example, the resistance of a Pt100 is $108.96\ \Omega$.

S

Seal

Most of today's process connections are sealed using a sealing device, e.g. an Elastomer-O-Ring. Depending on the type of the process connection, either Elastomer sealing devices or metal seals are used. When deciding on a sealing device, it is important to pay heed to the type of process connection being used and which environmental conditions, e.g. temperature or chemical corrosiveness of the process medium, the sealing device has to withstand. Process connections with a conical thread (e.g. NPT) do not require a sealing device. These process connections are self-sealing within the thread itself and are sealed using Teflon tape or a sealing compound.

Span

The span refers to the difference between the output signals at the lower and upper range limits. Thus, a 4 to 20 mA current output has a span of 16 mA.

Stainless steel

Alloyed and non-alloyed steels with a particular purity are described as stainless steel; colloquially, above all non-rusting steels are meant. There are differing identification standards for stainless steel alloys, of which EN 10027-2 (e.g. "1.4404") and the American Iron and Steel Institute (e.g. 316L) are the most well known. SICK applies, for example, the following stainless steels as chemical substances:

- 1.4404 (316L): X2CrNiMo17-12-2
- 1.4435 (316L): X2CrNiMo18-14-3
- 1.4571 (316Ti): X6CrNiMoTi17-12-2

T

TDR

TDR (Time Domain Reflectometry) is a transit time technique in which a microwave impulse is coupled with a probe. When the pulse hits the medium surface, part of the energy is reflected and, on the basis of the transit time of this signal, the distance of the reflection position is given. By analyzing the transit time, the process works uninfluenced by the properties of the medium and thus there is no need for adjustment. SICK's TDR level sensor LFT offers a universally applicable solution, which works in liquids with a dielectric constant of the medium of at least 1.8 and therefore in all conventional oil and water-based liquids.

Transmitter

A measuring instrument that converts the amplitude to be measured on the sensor into an output signal typical of the industry (e.g. 4 mA to 20 mA or 0 V to 10 V) is referred to as a transmitter.

U

UL

The UL (Underwriters Laboratories Inc.), headquartered in Northbrook, Illinois, USA, is an American company, which undertakes product safety testing and issues appropriate certificates. Founded as a public service company for fire insurance companies, today UL also focuses on fire protection. The certificates issued by UL include UL Listing and UL Recognized Component as well as a number of other certificates for particular product groups.

Ultrasonic

Ultrasonic refers to frequencies between 20 Kilohertz and 1 Gigahertz. Ultrasonic devices in fluid sensors are used in the measurement of distances (e.g. in level measurement of containers) and of quantities (e.g. flow measurement in conduits). Vibration is typically generated piezoelectrically. The transit time between emission of the ultrasonic signal and reception of the reflection is measured.

V

Vibration measurement

Vibration measurement (also known as the tuning-fork principle) is an adjustment-free process for point level measurement in fluids and solids. The reliable measuring method is based on the piezoelectric generation of a vibration, which is transmitted to a fork inside the tank. As soon as the tuning fork is covered by liquid or solid matter, there is a change in the vibration. This frequency or amplitude change is detected piezoelectrically. In contrast to the point level measurement by means of float gauges or capacitive switches, this technology is easier to install, hardly dependent on medium properties and very reliable against contamination.

W

WHG

 The German Law on the Regulation of Water (Water Act – WHG) regulates the protection and use of water. Here, the use of overflow protection in containers with substances hazardous to water is stipulated. For use as overflow protection, the Deutsche Institut für Bautechnik (DiBt) in Berlin issues the appropriate authorization. SICK's sensors of the LfV200 and LfV300 product families have, for example, received this certification.

Fluid sensors at SICK – all from one source

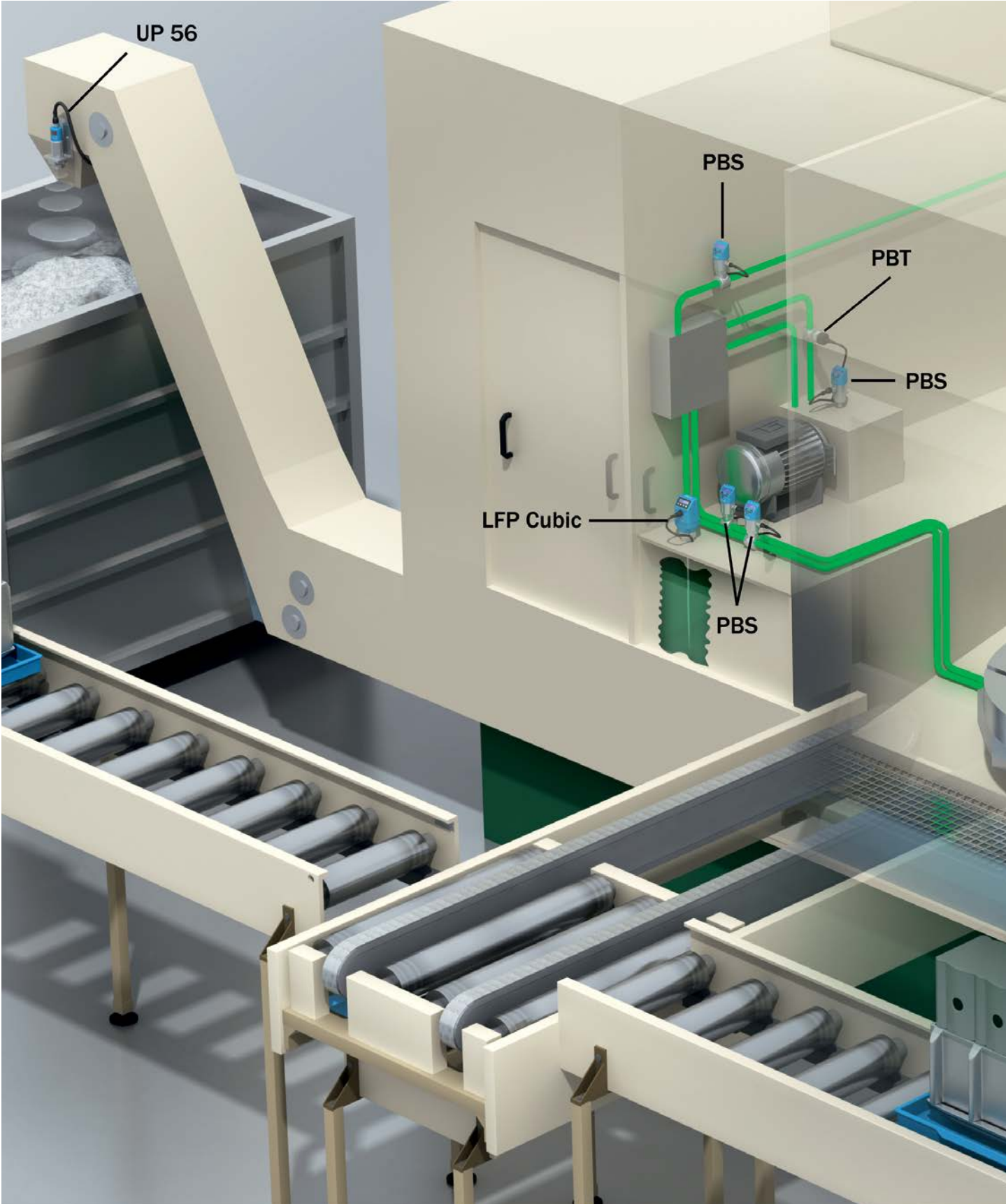

F

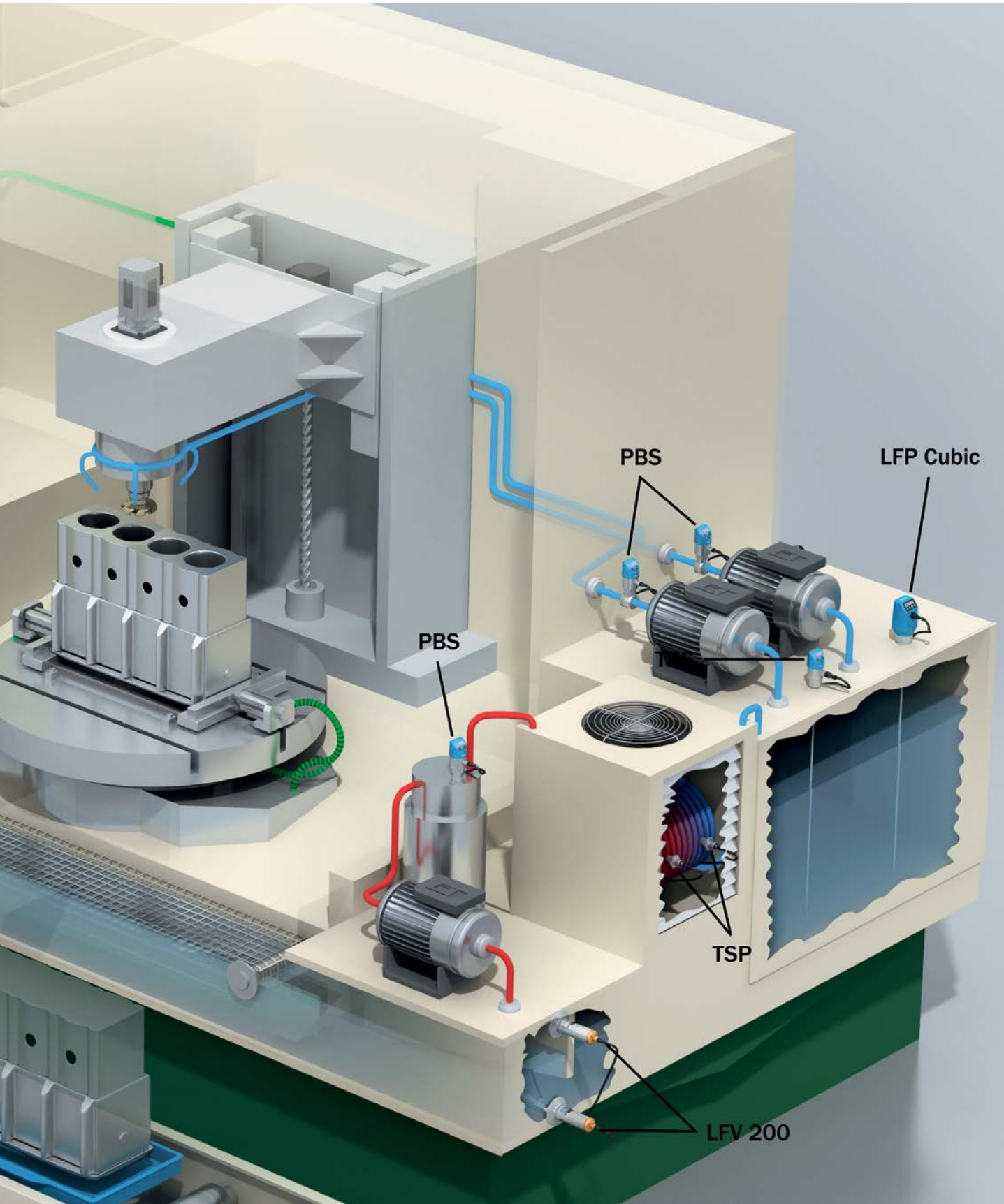

Explosion protection according to ATEX

ATEX Directive 94/9

The directive 94/9/EC has created in the European Union the framework for approximation of the laws of the Member States concerning equipment and protective systems for correct use in potentially explosive atmospheres. Generally called ATEX (for "Atmosphère explosible"), this directive was implemented in Germany with the 11th Ordinance of the Equipment and Product Safety Act ("Explosion Protection Regulation"/11th GPSGV). Thus, there exist detailed rules for the marketing of new equipment and protective systems for use in explosive atmospheres. In accordance with the regulations of the directive, products are classified into equipment groups and categories.

Equipment groups

Equipment group I

Encompasses equipment for use in underground mining including surface equipment.

Equipment group II

Encompasses equipment for use in surface operations and is subdivided into categories 1 - 3.

Categories and criteria

Category 1 – Very high safety measures

Equipment for use in areas (zones) in which explosive atmospheres are present continuously, long-term or frequently. Even for rarely occurring problems, explosion protection must be guaranteed. This category corresponds to Zones 0 for gases, vapors and mists, as well as 20 for dust environments, where explosive atmosphere occurs continuously, long-term or frequently in form of a cloud of combustible dust in the air.

The conditions of Zones 0 or 20 might also occur inside containers, pipelines and equipment.

Category 2 – High safety measures

Equipment for use in areas (zones) in which explosive atmospheres only occasionally occur. Explosion protection must also be guaranteed for frequently occurring equipment problems. This category corresponds to Zones 1 for gases, vapors and mists, as well as 21 for dust environments, where explosive atmosphere occurs occasionally in form of a cloud of combustible dust in the air under normal operation. This zone can, for example, include areas in the immediate vicinity of e.g. powder filling and emptying points and areas where dust deposits occur and in normal operation give rise occasionally to an explosive concentration of combustible dust when mixed with air.

Category 3 – Normal safety measures

Equipment for use in areas (zones) in which explosive atmospheres are not expected to occur. However, in the event that an explosive atmosphere does occur, it occurs only very rarely and only temporarily. Under normal operation, category 3 equipment must guarantee the required safety measures. The category corresponds to Zone 2 for gases, vapors and mists, as well as 22 for dust.

Equipment group II						
Equipment for use in other hazardous areas						
	Category 1		Category 2		Category 3	
Danger	Constant, frequent or over a long period		Occasional		Seldom and over a short period	
Requirements	Very high safety		High safety		Normal safety	
Zone	Zone 0	Zone 20	Zone 1	Zone 21	Zone 2	Zone 22
Substance group	G	D	G	D	G	D

G = gas, D = dust

Certificate

After a test body for a device has ensured compliance with the basic safety requirements, it generates a test report. This test report is the basis for a certificate authority (notified body) to issue an EC type-examination certificate.

The CE and ATEX symbols may only be attached to the product when yet another certificate of a notified body per Directive 97/9 concerning the quality assurance of the production of the products has also been granted for the corresponding product group and when the manufacturer has issued a conformity declaration concerning the conformity of the products with the construction type treated in the EC type-examination certificate.

Principles of explosion protection

To establish uniform standards in the determination of protective measures, flammable liquids and gases are divided into explosion groups and temperature classes based on their explosion-relevant properties.

Explosive groups

Gases and vapors are classified into three explosive groups (IIA, IIB and IIC) based on their specific flammability. The danger increases from explosion group IIA to IIC (the higher IIC explosion group always includes the lower IIB and IIA groups).

Temperature classes

To facilitate the planning of an installation, six temperature classes (T1 to T6) have been established for the approved surface temperatures. Depending on their respective ignition temperatures, certain flammable gases and vapors can be classified under these temperature classes. For the temperature classes, the following maximum allowable surface temperatures are valid for equipment (the higher temperature classes encompass the lower classes, e.g. T6 includes the lower temperature classes T5 to T1):

Class		Max. surface temperature	
T1	450 °C	T4	135 °C
T2	300 °C	T5	100 °C
T3	200 °C	T6	85 °C

Types of flammable protection

Technical means must be used to ensure that no ignition source can take effect according to the classification of a given explosive mixture (gap width, temperature class). There are several technical possibilities to achieve explosion protection of an electrical device. The types of flammable protection are listed in the table. On the explosive identification label of a device, the type of flammable protection accorded to the device is indicated by the initial letters of the type of flammable protection.

Flammable protection	Description
Flameproof Encapsulation d (drive enclosure)	The components that could trigger ignition are installed in a housing that withstands the explosion pressure. The openings of the housing are designed such that an outward transmission of the explosion is prevented.
Enhanced safety e (enhanced safety)	The development of sparks, electric arcs, or impermissible temperatures that could function as a source of ignition, is prevented by additional measures and an increased degree of safety.
Pressurized apparatus p (pressurization, purging)	The device housing is filled with a protective gas. An excess pressure is maintained so that an explosive gas mixture cannot reach the possible ignition sources arranged in the interior of the enclosure. If necessary, gas flows continuously through the enclosure.
Intrinsic safety i (intrinsic safety)	The supply of the electric equipment is led through a safety barrier that limits current and voltage to such an extent that the minimum ignition energy and ignition temperature of an explosive mixture is not reached.
Oil immersion o (oil immersion)	The parts of the electric equipment from which an ignition can arise are immersed in a protective liquid (mostly oil).
Sand encasing q (quartz filled)	The equipment is filled with fine-grained sand. A possible electric arc is cooled so much that the ignition of an explosive mixture is impossible. The surface temperature must not exceed the limit value.
Molded encapsulation m (molded)	The parts of the electric equipment that can create ignition sources are embedded in casting compound so that an electric arc cannot pass through to an explosive mixture outside the casing.
Ignition protection methods n (non-incendive, non-sparking)	In normal operation and with defined errors, there is no risk of ignition from the electric equipment.

All data without guarantee

Materials

Stainless steels

Number	DIN	VA	ASTM	BS	NF	SIS	EN
1.4122	X 35 CrMo 17-1	2	-	-	-	-	X39CrMo17
1.4300	X 12 CrNi 18 8	2	302	302 S 25	-	-	-
1.4301	X 5 CrNi 18 10	2	304	304 S 31	Z 7 CN 18-09	2332/33	X5CrNi18-10
1.4305	X 10 CrNiS 18 9	2	303	303 S 22	Z 8 CNF 18-09	2346	X8CrNiS18-9
1.4310	X 12 CrNi 17 7	2	301	301 S 22	Z 12 CN 18-08	2331	X10CrNi18-8
1.4401	X 5 CrNiMo 17 12 2	-	316	316 S 31	Z 7 CND 17-11-02	2347	X5CrNiMo17-12-2
1.4404	X 2 CrNiMo 17 12 2	4	316L	316 S 11	Z 3 CND 17-11-02	2348	X2CrNiMo17-12-2
1.4408	G-X 6 CrNiMo 18 10	-	-	-	-	-	GX5CrNiMo 19-11-2
1.4410	G-X 10 CrNiMo 18 9	-	-	-	-	-	-
1.4435	X 2 CrNiMo 18 14 3	-	316L	316 S 11	Z 3 CND 17-12-03	2353	X2CrNiMo18-14-3
1.4436	X 5 CrNiMo 17 13 3	4	316	316 S 33	Z 6 CND 18-12-03	2343	X3CrNiMo17-13-3
1.4462	X 2 CrNiMoN 22 5 3	-	S 31803	318 S 13	Z 3 CND 22-05 Az	2377	X2CrNiMoN22-5-3
1.4541	X 6 CrNiTi 18 10	2	321	321 S 31	Z 6 CNT 18-12	2337	X6CrNiTi18-10
1.4571	X 6 CrNiMoTi 17 12 2	4	316 Ti	320 S 18	Z 6 CNDT 17-12	2360	X6CrNiMoTi17-12-2

Elastomers

DIN/ISO	ATSM	Designation
EPDM	EPDM	Ethylene propylene diene monomer
FPM	FKM	Fluorinated rubber
NBR	NBR	Nitrile butadiene rubber

Plastics

Abbreviation	Designation
ABS	Acrylonitrile butadiene styrene
PA	Polyamide
PBT	Polybutylene terephthalate
PC	Polycarbonate
PEEK	Polyether ether ketone
PFA	Perfluoroalkoxy polymer
POM	Polyoxymethylene
PP	Polypropylene
PS	Polystyrene
PSU	Polysulfone
PTFE	Polytetrafluoroethylene (Teflon)
PVC	Polyvinyl chloride
PVDF	Polyvinylidene fluoride

Pressure units

	bar	MPa	kg/cm ²	psi	mmHg (0 °C)	torr	inchHg (60 °F)	mmH ₂ O (16 °C)	inchH ₂ O (60 °F)
1 bar	1	0.1	1.0197	14.504	750.062	750.062	29.611	10207.1	401.86
1 MPa	10	1	10.20	145.04	7500.62	7500.62	296.11	102071	4018.56
1 kg/cm ²	0.9807	0.0980	1	14.22	735.56	735.56	29.038	10010	394.085
1 psi	0.0689	0.0069	0.0703	1	51.7148	51.7148	2.0416	703.75	27.7069
1 mmHg (0 °C)	0.0013	0.00013	0.00136	0.0193	1	1	0.0395	13.608	0.5358
1 torr	0.0013	0.00013	0.00136	0.0193	1	1	0.0395	13.608	0.5358
1 inchHg (60 °F)	0.0338	0.00338	0.03444	0.48982	25.331	25.331	1	344.71	13.571
1 mmH ₂ O (16 °C)	0.0001	9.7971E-06	9.9903E-05	0.00142	0.07348	0.07348	0.00290	1	0.0394
1 inchH ₂ O (60 °F)	0.0025	0.000249	0.00254	0.0361	1.866	1.866	0.0737	25.400	1

bar	(bar)	= 100.000 Pa = 0.1 MPa
atm	(physical or standard atmosphere)	≈ 101.325 Pa
PSI	(pounds per square inch)	≈ 6895 Pa
mmHg	(millimeters of mercury)	≈ 133 Pa
torr	(= mmHg)	≈ 133 Pa
inchHg	(inches of mercury)	≈ 3.390 Pa
mmH ₂ O	(millimeters of water)	≈ 9.81 Pa
inchH ₂ O	(inches of water)	≈ 249 Pa

All data without guarantee

Temperature units

The two most common units of temperature measurement are Celsius (°C) and Fahrenheit (°F). While Celsius is used worldwide, Fahrenheit is particularly common in the USA.

Conversion from °C to °F: $T(^{\circ}\text{C}) = \frac{5}{9} \times (T(^{\circ}\text{F}) - 32 \text{ }^{\circ}\text{F})$

Conversion from °F to °C: $T(^{\circ}\text{F}) = \frac{9}{5} \times T(^{\circ}\text{C}) + 32$

Both units of measurement have the same value at:

$$-40 \text{ }^{\circ}\text{C} = -40 \text{ }^{\circ}\text{F}$$

Kelvin [K] is used to express temperature differences. The temperature differences in the use of Celsius and Kelvin match.

Dielectric constants

Substance	DC value	Substance	DC value	Substance	DC value
Acetal (25 °C)	3.8	Benzyl alcohol	13.5	Ether	4.0
Acetaldehyde	15.0	Benzyl amine	4.6	Ethyl acetate	6.0
Acetamide (77 °C)	59.2	Benzyl chloride	7.0	Ethylamine	6.9
Acetic acid	6.2	Bitumen	2.8	Ethyl benzoate	6.0
Acetoacetic acid ethyl ester	15.0	Black liquor	32.0	Ethyl benzene	2.4
Acetone	21.5	Bore oil emulsion	25.0	Ethylene chlorhydrin	25.0
Acetophenone	18.0	Bornyl acetate	4.6	Ethylene chloride	10.6
Acetylacetone	23.0	Bromine	3.1	Ethylenediamine	15.0
Acetyl bromide	16.2	Butanoic acid	3.0	Etylene oxide (-1 °C)	13.9
Acetyl chloride	15.9	Camphene	2.3	Ethyl mercaptan	6.9
Acetylene dibromide	7.2	Caproic acid (71 °C)	2.6	Fatty acid (35 °C)	1.7
Acetylene tetrabromide	5.6	Caprylic acid	2.5	Fenchone	12.8
Aconite acid ester	6.3	Carbon tetrachloride	2.3	Ferrous sulphate (80 °C)	32.4
Adipic acid	1.8	Carbonic acid diethyl ester	2.8	Fish oil	2.6
Alum (60 °C)	4.2	Carbonyl cyanide	10.7	Fluorbenzene	6.4
Allyl alcohol	20.6	Cellit	1.6	Formamide	109.0
Allyl chloride	8.2	Cetyl alcohol (60 °C)	3.6	Formic acid	57.9
Allyl iodide	6.1	Chlorine, liquid	2.1	Furan	3.0
Aluminum bromide (100 °C)	3.4	Chloral	6.7	Furfural	41.7
Aluminum hydroxide	2.5	Chlorobenzene	5.7	Germanium tetrachloride	2.4
Aluminum splinters	7.3	Chloroacetic acid	33.4	Glucose (50 °C)	30.0
Aluminum sulfate	2.6	Chlorohydrin	31.0	Glycerin	13.2
Ammonia	15.0	Chlorinated lime	2.3	Glycerol water	37.0
Ammonia solution (25 %)	31.6	Chloroform (trichlormethane)	4.8	Glycol	37.0
Amyl alcohol	14.8	Cresol	11.0	Glycantin	25.0
Amyl amine	4.5	Cresol resin	18.3	Granuform	4.0
Aniline	7.0	Cuminaldehyde	10.7	Guaiacol	11.0
Anisealdehyde	22.3	Cyanogen	2.5	Heating oil	2.1
Anisole	4.5	Decalin	2.1	Heavy fuel oil	2.2
Anthracite	3.2	Degalan	3.1	Helium	1.1
Antimony hydride	1.8	Desmodur	10.0	Heptane	1.9
Argon	1.5	Diacetone alcohol	18.2	Heptanal	9.1
Arsine	2.1	Diaryl ether	3.0	Heptanoic acid (71 °C)	2.6
Arsone	2.3	Dibenzofuran (100 °C)	3.0	Heptene	2.1
Ascorbic acid (vitamin C)	2.1	Dibenzyl (60 °C)	2.5	Hexane	1.9
Azelaic acid diethyl ester	5.0	Diesel fuel	2.1	Hexanol	12.5
Azoxybenzene (36 °C)	5.2	Diethylamine	3.8	Hexene	2.1
Beer brew	25.0	Dimethylether (methyl ether)	5.0	Hot glue (150 °C)	2.3
Benzal chloride	6.9	Diofan	32.0	Hydrazine	58.0
Benzaldehyde	17.6	Dioxane	2.0	Hydrochloric acid	5.0
Benzil (80 °C)	10.0	Diphenyl (75 °C)	2.5	Hydrocyanic acid	158.0
Benzine	2.0	Emulphor	4.0	Hydrogen	1.2
Benzene	2.3	Epichlorhydrin	23.0	Hydrogen fluoride (0 °C)	83.6
Benzene, heavy	3.2	Ethanol (ethyl alkohol)	16.2	Hydrogen iodide	2.9

Substance	DC value
Hydrogen peroxide, pure (0 °C)	84.2
Hydrogen sulfide	6.0
Imidazole, pure (100 °C)	23.0
Iodine	11.1
Iodobenzene	4.6
Iodomethane	7.1
Isoamyl acetate	4.8
Isoamyl alcohol	15.6
Isoamyl bromide	6.0
Isoamyl chloride	6.1
Isoamyl ether	2.8
Isoamyl iodide	5.6
Isobutanoic acid	2.6
Isobutyl alcohol	18.1
Isobutyl amine	4.4
Isobutyl benzene	2.3
Isobutyl bromide	7.2
Isobutyl chloride	6.5
Isobutyl cyanide	18.0
Isobutyl iodide	6.5
Isobutyl nitrate	11.7
Isobutyl silane	2.5
Isocyanate	6.1
Isoprene	2.1
Isopropanol	18.0
Isoquinoline	10.7
Isosafrole	3.3
Lanolin	4.2
Latex	24.0
Laughing gas	1.5
Lauric acid ethyl ester	3.4
Linoleic acid	2.7
Malic acid diethylester	10.0
Mandelic acid nitril	18.0
Menthol (42 °C)	4.0
Mercury diethyl	2.1
Mesityl oxide	15.0
Methanol (methyl alcohol)	33.0
Methyl acetate	8.0
Methylene bromide	7.0
Methylene chloride	9.0
Methylene chloride	9.1
Metylene iodide	5.3
Methyl nitrate	23.5

Substance	DC value
Methyl cellulose	3.0
Mono chlormethane	9.8
Morpholine	7.3
Naphthenic acid	2.6
Nitric acid (98%)	19.0
Nitrobenzene	35.0
Nitroethane	29.0
Nitroglycol	28.3
Nitro varnish	5.2
Nitromethane	39.0
Nitrosyl bromide (13 °C)	15.2
Nitrosyl chloride	19.0
Octane	2.0
Octene	2.1
Octyl bromide	5.0
Oil	2.0
Oleic acid	2.5
Oxalo ethyl acetate	6.0
Oxygen	1.5
Palmitic acid	2.3
Paraffin	1.6
Paraldehyde	15.1
Pelargon	2.8
Penta borane	21.0
Penta ethyl chloride	3.8
Penta chlortoluene	4.8
Pentane	1.8
Pentene	2.0
Perchlorate	3.6
Perchlorobutadiene	2.6
Phenetole	4.2
Phenol	8.0
Phenol resin	7.4
Phosphorus, liquid	3.9
Pinane	2.1
Piperidine	5.8
Polyamide pellets	1.7
Polyethylene	1.2
Polypropylene	1.6
Polyrol	2.8
Polyvinyl acetals	2.8
Potassium lye	3.3
Potato starch	1.7
Propanoic acid	3.2

Substance	DC value
Propanol (propyl alcohol)	2.2
Propionaldehyde (15 °C)	14.4
Propylamine	3.0
Propylene, liquid	1.9
Propylene chloride	9.0
Propylether	3.3
Pyridine	13.2
Pyrroles	8.0
Quinoline	8.8
Saccharose solution	20.0
Salt water	32.0
Silicic acid	2.0
Silicone oil	2.7
Sodium carbonate	3.0
Sodium methylate	1.5
Sodium perborate	2.2
Sodium peroxide	2.7
Sodium silicate	16.0
Sodium sulfate	2.7
Solvent	18.0
Stearic acid	2.3
Sulfuric acid	21.9
Sulfuric acid (15%)	31.0
Sulfuric acid (97%)	8.6
Sulfur trioxide	3.1
Sulphur dioxide	14.0
Tartaric acid	35.9
Terephthalic acid	1.5
Terpinene	2.7
Terpinolene	2.3
Tetrachlorethylene	2.5
Titanium tetrachloride	2.8
Trichloroethylene	3.2
Triptan	1.9
Turpentine substitute	2.0
Urea	2.9
Valeric acid	2.7
Water	80.3
Water (360 °C)	10.0
Water, demineralized	29.3
Water, demineralized	78.3
Wine	25.0
Xylene	2.3
Xylitol	40.0



SICK at a glance

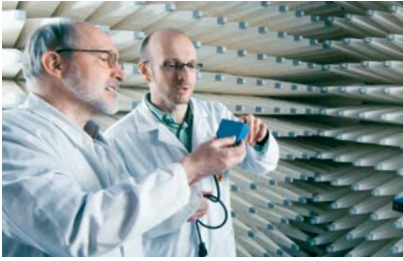

Leading technologies

With a staff of more than 5,800 and nearly 50 subsidiaries and representations worldwide, SICK is one of the leading and most successful manufacturers of sensor technology. The power of innovation and solution competency have made SICK the global market leader. No matter what the project and industry may be, talking with an expert from SICK will provide you with an ideal basis for your plans – there is no need to settle for anything less than the best.



Unique product range

- Non-contact detecting, counting, classifying, positioning and measuring of any type of object or media
- Accident and operator protection with sensors, safety software and services
- Automatic identification with bar code and RFID readers
- Laser measurement technology for detecting the volume, position and contour of people and objects
- Complete system solutions for analysis and flow measurement of gases and liquids



Comprehensive services

- SICK LifeTime Services – for safety and productivity
- Application centers in Europe, Asia and North America for the development of system solutions under real-world conditions
- E-Business Partner Portal www.mysick.com – price and availability of products, requests for quotation and online orders

Worldwide presence with subsidiaries in the following countries:

Australia
Belgium/Luxembourg
Brasil
Ceská Republika
Canada
China
Danmark
Deutschland
España
France
Great Britain
India
Israel
Italia
Japan

México
Nederland
Norge
Österreich
Polska
România
Russia
Schweiz
Singapore
Slovenija
South Africa
South Korea
Suomi
Sverige
Taiwan
Türkiye
United Arab Emirates
USA

Please find detailed addresses and additional representatives and agencies in all major industrial nations at www.sick.com