

Machine Automation Controller

CJ-series

Temperature Control Units

Operation Manual for NJ-series CPU Unit

CJ1W-TC003

CJ1W-TC004

CJ1W-TC103

CJ1W-TC104

Temperature Control Units



W491-E1-03

© **OMRON, 2011**

All rights reserved. No part of this publication may be reproduced, stored in a retrieval system, or transmitted, in any form, or by any means, mechanical, electronic, photocopying, recording, or otherwise, without the prior written permission of OMRON.

No patent liability is assumed with respect to the use of the information contained herein. Moreover, because OMRON is constantly striving to improve its high-quality products, the information contained in this manual is subject to change without notice. Every precaution has been taken in the preparation of this manual. Nevertheless, OMRON assumes no responsibility for errors or omissions. Neither is any liability assumed for damages resulting from the use of the information contained in this publication.

Introduction

Thank you for purchasing an CJ-series Temperature Control Units.

This manual contains information that is necessary to use with the NJ-series CPU Unit. Please read this manual and make sure you understand the functionality and performance of the NJ-series CPU Unit before you attempt to use it in a control system.

Keep this manual in a safe place where it will be available for reference during operation.

Intended Audience

This manual is intended for the following personnel, who must also have knowledge of electrical systems (an electrical engineer or the equivalent).

- Personnel in charge of introducing FA systems.
- Personnel in charge of designing FA systems.
- Personnel in charge of installing and maintaining FA systems.
- Personnel in charge of managing FA systems and facilities.

For programming, this manual is intended for personnel who understand the programming language specifications in international standard IEC 61131-3 or Japanese standard JIS B3503.

Applicable Products

This manual covers the following products.

- CJ-series Temperature Control Units
 - CJ1W-TC003
 - CJ1W-TC004
 - CJ1W-TC103
 - CJ1W-TC104

Relevant Manuals

There are three manuals that provide basic information on the NJ-series CPU Units: the *NJ-series CPU Unit Hardware User's Manual*, the *NJ-series CPU Unit Software User's Manual*, and the *NJ-series Instructions Reference Manual*.

Most operations are performed from the Sysmac Studio Automation Software. Refer to the *Sysmac Studio Version 1 Operation Manual* (Cat. No. W504) for information on the Sysmac Studio.

Other manuals are necessary for specific system configurations and applications.

Read all of the manuals that are relevant to your system configuration and application to make the most of the NJ-series CPU Unit.

	NJ-series User's Manuals								CJ-series Special Unit Operation Manuals for NJ-series CPU Unit
	Basic information			NJ-series CPU Unit Motion Control User's Manual	NJ-series CPU Unit Built-in EtherCAT Port User's Manual	NJ-series Motion Control Instructions Reference Manual	NJ-series CPU Unit Built-in EtherNet/IP Port User's Manual	NJ-series Troubleshooting Manual	
	NJ-series CPU Unit Hardware User's Manual	NJ-series CPU Unit Software User's Manual	NJ-series Instructions Reference Manual						
Introduction to NJ-series Controllers	●								
Setting devices and hardware									
Using motion control				●					
Using EtherCAT	●				●				
Using EtherNet/IP							●		
Using CJ-series Units									●
Software settings									
Using motion control		●		●					
Using EtherCAT					●				
Using EtherNet/IP							●		
Programming		●	●						
Using motion control				●		●			
Using EtherCAT					●				
Using CJ-series Units									●
Programming error processing								●	
Testing operation and debugging									
Using motion control		●		●					
Using EtherCAT					●				
Using EtherNet/IP							●		
Troubleshooting and managing errors in an NJ-series Controller	△	△		△			△		△
	Use the relevant manuals for references according to any error that occurs.								
Maintenance									
Using EtherCAT	●				●				
Using EtherNet/IP							●		
Using CJ-series Units									●

Manual Configuration

NJ-series CPU Unit Hardware User's Manual (Cat. No. W500)

Section	Description
Section 1 Introduction	This section provides an introduction to the NJ-series Controllers and their features, and gives the NJ-series Controller specifications.
Section 2 System Configuration	This section describes the system configuration used for NJ-series Controllers.
Section 3 Configuration Units	This section describes the parts and functions of the configuration devices in the NJ-series Controller configuration, including the CPU Unit and Configuration Units.
Section 4 Installation and Wiring	This section describes where and how to install the CPU Unit and Configuration Units and how to wire them.
Section 5 Troubleshooting	This section describes the event codes, error confirmation methods, and corrections for errors that can occur.
Section 6 Inspection and Maintenance	This section describes the contents of periodic inspections, the service life of the Battery and Power Supply Units, and replacement methods for the Battery and Power Supply Units.
Appendices	The appendices provide the specifications of the Basic I/O Units, Unit dimensions, load short-circuit protection detection, line disconnection detection, and measures for EMC Directives.

NJ-series CPU Unit Software User's Manual (Cat. No. W501)

Section	Description
Section 1 Introduction	This section provides an introduction to the NJ-series Controllers and their features, and gives the NJ-series Controller specifications.
Section 2 CPU Unit Operation	This section provides information that is necessary to use the CPU Unit, including how the CPU Unit works and the operations that it performs depending on the status of the CPU Unit.
Section 3 I/O Ports, Slave Configuration, and Unit Configuration	This section describes how to use I/O ports, how to create the slave configuration and unit configuration and how to assign functions.
Section 4 Controller Setup	This section describes the initial settings of the function modules.
Section 5 Designing Tasks	This section describes the task system and types of tasks.
Section 6 Programming	This section describes programming, including the programming languages and the variables and instructions that are used in programming.
Section 7 Checking Operation and Actual Operation	This section describes the items and procedures for checking the operation of an NJ-series Controller, including offline debugging procedures.
Section 8 CPU Unit Functions	This section describes the functionality provided by the CPU Unit.
Section 9 Communications Setup	This section describes how to go online with the CPU Unit and how to connect to other devices.
Section 10 Example of Actual Application Procedures	This section describes the procedures that are used to actually operate an NJ-series Controller.
Section 11 Troubleshooting	This section describes the event codes, error confirmation methods, and corrections for errors that can occur.
Appendices	The appendices provide the CPU Unit specifications, task execution times, specifications of individual system-defined variables, data attribute lists, CJ-series Unit memory information, CJ-series Unit memory allocation methods, and version information.

Sysmac Studio Version 1 Operation Manual (Cat. No. W504)

Section	Description
Section 1 Introduction	This section provides an overview and lists the specifications of the Sysmac Studio and describes its features and components.
Section 2 Installation and Uninstallation	This section describes how to install and uninstall the Sysmac Studio.
Section 3 System Design	This section describes the basic concepts for designing an NJ-series System with the Sysmac Studio and the basic operating procedures.
Section 4 Programming	This section describes how to create programs with the Sysmac Studio.
Section 5 Online Connections to a Controller	This section describes how to go online with a Controller.
Section 6 Debugging	This section describes how to debug the programs online on the Controller or debug it offline with the Simulator.
Section 7 Other Functions	This section describes other functions that are supported by the Sysmac Studio, including security functions and troubleshooting functions.
Section 8 Reusing Programming	This section describes how to reuse the programs that you create with the Sysmac Studio.
Section 9 Support Software Provided with the Sysmac Studio	This section describes the Support Software that is provided with the Sysmac Studio.
Section 10 Troubleshooting	This section describes the error messages that are displayed when you check a program on the Sysmac Studio and how to correct those errors.
Appendices	The appendices describe the following: Driver Installation for Direct USB Cable Connection Specifying One of Multiple Ethernet Interface Cards Online Help Simulation Instructions

CJ-series Temperature Control Units Operation Manual for NJ-series CPU Unit (Cat. No. W491) (This manual)

Section	Description
Section 1 Features and System Configuration	This section describes the features and the system configuration of the Temperature Control Unit.
Section 2 Specifications and Functions	This section describes the specifications, the functionality, and the operating procedure for the Temperature Control Unit, and where and how to wire the Unit.
Section 3 Settings Required for Temperature Control	This section explains the various settings required for temperature control of the Temperature Control Unit.
Section 4 Optional Settings	This section explains the optional settings for the Temperature Control Unit.
Section 5 Error and Alarm Processing	This section describes the troubleshooting procedure for the Temperature Control Unit.
Appendices	---

CJ Series Temperature Control Units OPERATION MANUAL (Cat. No. W396)

Section	Description
Section 1 Features and System Configuration	This section describes the features of the Temperature Control Unit and its basic system configuration.
Section 2 Specifications and Functions	This section describes the functions and specifications of the Temperature Control Unit, including technical specifications, Unit parts, wiring, and data allocations.
Section 3 Settings Required for Temperature Control	This section explains the various settings required for temperature control.
Section 4 Optional Settings	This section explains how to use the input compensation value.
Section 5 Error and Alarm Processing	This section provides information on troubleshooting and error processing.
Appendices	---

Manual Structure

Page Structure

The following page structure is used in this manual.

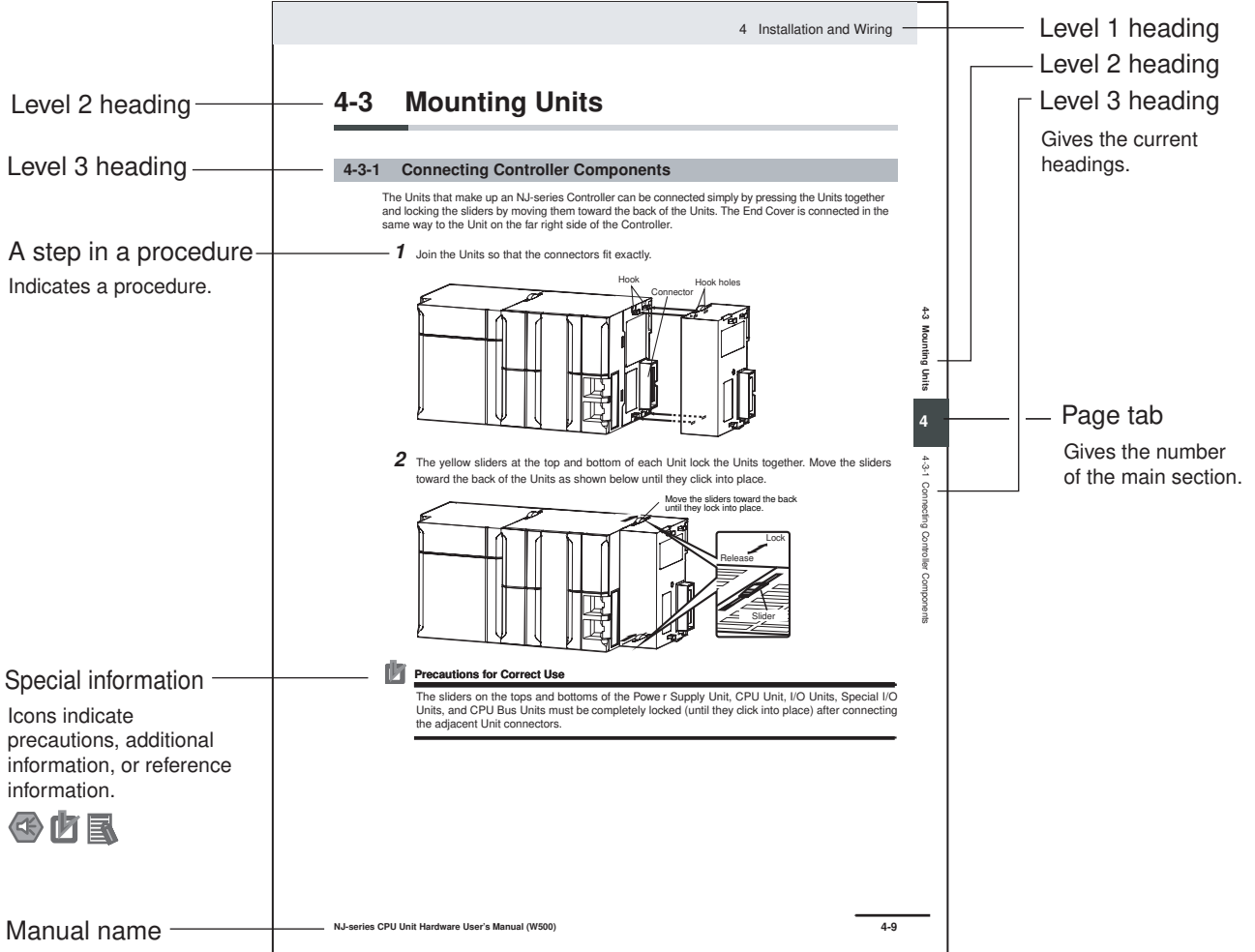

This illustration is provided only as a sample. It may not literally appear in this manual.

Special Information

Special information in this manual is classified as follows:



Precautions for Safe Use

Precautions on what to do and what not to do to ensure safe usage of the product.



Precautions for Correct Use

Precautions on what to do and what not to do to ensure proper operation and performance.



Additional Information

Additional information to read as required.

This information is provided to increase understanding or make operation easier.

Note References are provided to more detailed or related information.

Precaution on Terminology

In this manual, “download” refers to transferring data from the Sysmac Studio to the physical Controller and “upload” refers to transferring data from the physical Controller to the Sysmac Studio.

For the Sysmac Studio, synchronization is used to both upload and download data. Here, “synchronize” means to automatically compare the data for the Sysmac Studio on the computer with the data in the physical Controller and transfer the data in the direction that is specified by the user.

Sections in this Manual

1	Features and System Configuration	1
2	Specifications and Functions	2
3	Settings Required for Temperature Control	3
4	Optional Settings	4
5	Error and Alarm Processing	5
A	Appendices	A
I	Index	I

CONTENTS

Introduction	1
Relevant Manuals	2
Manual Configuration	3
Manual Structure	6
Sections in this Manual	9
CONTENTS.....	10
Read and Understand this Manual	13
Safety Precautions	16
Precautions for Safe Use.....	21
Precautions for Correct Use.....	27
Regulations and Standards.....	31
Unit Versions	33
Related Manuals	35
Revision History	36

Section 1 Features and System Configuration

1-1 Introduction and Features	1-2
1-1-1 Introduction	1-2
1-1-2 Features	1-3
1-2 System Configuration	1-7
1-2-1 Basic System Configuration	1-7
1-2-2 Mounting the Unit.....	1-8

Section 2 Specifications and Functions

2-1 Specifications	2-2
2-1-1 Specifications	2-2
2-1-2 Input Function Block Diagram	2-5
2-1-3 Input Specifications	2-5
2-2 Application Procedure	2-7
2-3 Part Names and Functions	2-11
2-3-1 Part Names	2-11
2-3-2 Indicators.....	2-11
2-3-3 Unit Number Switches.....	2-12
2-3-4 DIP Switch Setting Functions.....	2-13
2-3-5 Input Type Switch	2-15

2-4	Wiring	2-16
2-4-1	Terminal Wiring Examples	2-16
2-4-2	Output Circuits	2-17
2-4-3	I/O Wiring Examples	2-18
2-5	Data Exchange with the CPU Unit	2-21
2-5-1	Overview	2-21
2-5-2	Accessing from the User Program	2-22
2-5-3	Saving Set Value in the Non-volatile Memory	2-23
2-5-4	Operation Data	2-24
2-5-5	Initialization Data	2-30
2-5-6	Operating Parameters.....	2-32
2-6	Range of Set Values and Monitor Values	2-35
2-6-1	Set Values.....	2-35
2-6-2	Monitor Values	2-37

Section 3 Settings Required for Temperature Control

3-1	Setting the Input Type	3-2
3-2	Selecting the Temperature Units	3-4
3-3	Setting the Pin 3 of the DIP Switch	3-5
3-4	Selecting the Control Operation (Forward/Reverse)	3-6
3-5	Selecting PID Control or ON/OFF Control	3-7
3-6	Setting the Control Period	3-8
3-7	Setting the Set Points	3-9
3-8	Using ON/OFF Control	3-10
3-9	Setting the PID Constants	3-11
3-10	Using the Alarm Output Function	3-15
3-11	Using the Heater Burnout Alarm	3-19
3-12	Starting and Stopping Temperature Control	3-21

Section 4 Optional Settings

4-1	Shifting the Input Value (Input Compensation)	4-2
4-2	Recovering from Sensor Not Connected Errors	4-3

Section 5 Error and Alarm Processing

5-1	Error and Alarm Processing	5-2
5-2	Troubleshooting	5-10
5-3	Event Logs	5-16
5-3-1	Overview of the Event Logs	5-16
5-3-2	Error Table	5-17
5-3-3	Error Descriptions	5-18

Appendices

A-1	Dimensions	A-2
A-2	Functional Differences due to CPU Units (NJ/CJ-series) to be Connected	A-3
A-3	Correspondence Table of Device Variables for CJ-series Unit and Memory Used for CJ-series Unit Addresses	A-4
A-4	Sample Programming.....	A-10

Index

Read and Understand this Manual

Please read and understand this manual before using the products. Please consult your OMRON representative if you have any questions or comments.

Warranty and Limitations of Liability

WARRANTY

OMRON's exclusive warranty is that the products are free from defects in materials and workmanship for a period of one year (or other period if specified) from date of sale by OMRON.

OMRON MAKES NO WARRANTY OR REPRESENTATION, EXPRESS OR IMPLIED, REGARDING NON-INFRINGEMENT, MERCHANTABILITY, OR FITNESS FOR PARTICULAR PURPOSE OF THE PRODUCTS. ANY BUYER OR USER ACKNOWLEDGES THAT THE BUYER OR USER ALONE HAS DETERMINED THAT THE PRODUCTS WILL SUITABLY MEET THE REQUIREMENTS OF THEIR INTENDED USE. OMRON DISCLAIMS ALL OTHER WARRANTIES, EXPRESS OR IMPLIED.

LIMITATIONS OF LIABILITY

OMRON SHALL NOT BE RESPONSIBLE FOR SPECIAL, INDIRECT, OR CONSEQUENTIAL DAMAGES, LOSS OF PROFITS OR COMMERCIAL LOSS IN ANY WAY CONNECTED WITH THE PRODUCTS, WHETHER SUCH CLAIM IS BASED ON CONTRACT, WARRANTY, NEGLIGENCE, OR STRICT LIABILITY.

In no event shall the responsibility of OMRON for any act exceed the individual price of the product on which liability is asserted.

IN NO EVENT SHALL OMRON BE RESPONSIBLE FOR WARRANTY, REPAIR, OR OTHER CLAIMS REGARDING THE PRODUCTS UNLESS OMRON'S ANALYSIS CONFIRMS THAT THE PRODUCTS WERE PROPERLY HANDLED, STORED, INSTALLED, AND MAINTAINED AND NOT SUBJECT TO CONTAMINATION, ABUSE, MISUSE, OR INAPPROPRIATE MODIFICATION OR REPAIR.

Application Considerations

SUITABILITY FOR USE

OMRON shall not be responsible for conformity with any standards, codes, or regulations that apply to the combination of products in the customer's application or use of the products.

At the customer's request, OMRON will provide applicable third party certification documents identifying ratings and limitations of use that apply to the products. This information by itself is not sufficient for a complete determination of the suitability of the products in combination with the end product, machine, system, or other application or use.

The following are some examples of applications for which particular attention must be given. This is not intended to be an exhaustive list of all possible uses of the products, nor is it intended to imply that the uses listed may be suitable for the products:

- Outdoor use, uses involving potential chemical contamination or electrical interference, or conditions or uses not described in this manual.
- Nuclear energy control systems, combustion systems, railroad systems, aviation systems, medical equipment, amusement machines, vehicles, safety equipment, and installations subject to separate industry or government regulations.
- Systems, machines, and equipment that could present a risk to life or property.

Please know and observe all prohibitions of use applicable to the products.

NEVER USE THE PRODUCTS FOR AN APPLICATION INVOLVING SERIOUS RISK TO LIFE OR PROPERTY WITHOUT ENSURING THAT THE SYSTEM AS A WHOLE HAS BEEN DESIGNED TO ADDRESS THE RISKS, AND THAT THE OMRON PRODUCTS ARE PROPERLY RATED AND INSTALLED FOR THE INTENDED USE WITHIN THE OVERALL EQUIPMENT OR SYSTEM.

PROGRAMMABLE PRODUCTS

OMRON shall not be responsible for the user's programming of a programmable product, or any consequence thereof.

Disclaimers

CHANGE IN SPECIFICATIONS

Product specifications and accessories may be changed at any time based on improvements and other reasons.

It is our practice to change model numbers when published ratings or features are changed, or when significant construction changes are made. However, some specifications of the products may be changed without any notice. When in doubt, special model numbers may be assigned to fix or establish key specifications for your application on your request. Please consult with your OMRON representative at any time to confirm actual specifications of purchased products.

DIMENSIONS AND WEIGHTS

Dimensions and weights are nominal and are not to be used for manufacturing purposes, even when tolerances are shown.

PERFORMANCE DATA

Performance data given in this manual is provided as a guide for the user in determining suitability and does not constitute a warranty. It may represent the result of OMRON's test conditions, and the users must correlate it to actual application requirements. Actual performance is subject to the OMRON Warranty and Limitations of Liability.

ERRORS AND OMISSIONS

The information in this manual has been carefully checked and is believed to be accurate; however, no responsibility is assumed for clerical, typographical, or proofreading errors, or omissions.

Safety Precautions

Definition of Precautionary Information

The following notation is used in this manual to provide precautions required to ensure safe usage of a CJ-series Temperature Control Unit. The safety precautions that are provided are extremely important to safety. Always read and heed the information provided in all safety precautions. The following notation is used.



WARNING

Indicates a potentially hazardous situation which, if not avoided, could result in death or serious injury. Additionally, there may be severe property damage.



Caution

Indicates a potentially hazardous situation which, if not avoided, may result in minor or moderate injury, or property damage.



Precautions for Safe Use

Indicates precautions on what to do and what not to do to ensure safe usage of the product.



Precautions for Correct Use

Indicates precautions on what to do and what not to do to ensure proper operation and performance.

Symbols



The circle and slash symbol indicates operations that you must not do. The specific operation is shown in the circle and explained in text. This example indicates prohibiting disassembly.

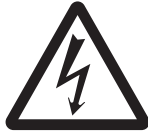

The triangle symbol indicates precautions (including warnings). The specific operation is shown in the triangle and explained in text. This example indicates a precaution for electric shock.



The triangle symbol indicates precautions (including warnings). The specific operation is shown in the triangle and explained in text. This example indicates a general precaution.



The filled circle symbol indicates operations that you must do. The specific operation is shown in the circle and explained in text. This example shows a general precaution for something that you must do.

WARNING

During Power Supply

Do not touch any of the terminals or terminal blocks while the power is being supplied. Doing so may result in electric shock.



Do not attempt to take any Unit apart. In particular, high-voltage parts are present in the Power Supply Unit while power is supplied or immediately after power is turned OFF. Touching any of these parts may result in electric shock. There are sharp parts inside the Unit that may cause injury.



Fail-safe Measures

Provide safety measures in external circuits to ensure safety in the system if an abnormality occurs due to malfunction of the CPU Unit, other Units, or slaves or due to other external factors affecting operation. Not doing so may result in serious accidents due to incorrect operation.



Emergency stop circuits, interlock circuits, limit circuits, and similar safety measures must be provided in external control circuits.



The Controller outputs may remain ON or OFF due to deposition or burning of the output relays or destruction of the output transistors. As a countermeasure for such problems, external safety measures must be provided to ensure safe operation of the system.



The CPU Unit will turn OFF all outputs from Basic Output Units in the following cases. The remote I/O slaves will operate according to the settings in the slaves.

- If an error occurs in the power supply
- If the power supply connection becomes faulty
- If a CPU watchdog timer error or CPU reset occurs
- If a major fault level Controller error occurs
- While the CPU Unit is on standby until RUN mode is entered after the power is turned ON



External safety measures must be provided to ensure safe operation of the system in such cases.

If external power supplies for slaves or other devices are overloaded or short-circuited, the voltage will drop, outputs will turn OFF, and the system may be unable to read inputs. Provide external safety measures in controls with monitoring of external power supply voltage as required so that the system operates safely in such a case.



WARNING

Fail-safe Measures

Unintended outputs may occur when an error occurs in variable memory or in memory used for CJ-series Units. As a countermeasure for such problems, external safety measures must be provided to ensure safe operation of the system.



Provide measures in the communications system and user program to ensure safety in the overall system even if errors or malfunctions occur in data link communications or remote I/O communications.



If there is interference in remote I/O communications or if a major fault level error occurs, output status will depend on the products that are used. Confirm the operation that will occur when there is interference in communications or a major fault level error, and implement safety measures. Correctly set all of the EtherCAT slaves.



The NJ-series Controller continues normal operation for a certain period of time when a momentary power interruption occurs. This means that the NJ-series Controller may receive incorrect signals from external devices that are also affected by the power interruption. Accordingly, take suitable actions, such as external fail-safe measures and interlock conditions, to monitor the power supply voltage of the external device as required.



You must take fail-safe measures to ensure safety in the event of incorrect, missing, or abnormal signals caused by broken signal lines, momentary power interruptions, or other causes. Not doing so may result in serious accidents due to incorrect operation.



Voltage and Current Inputs

Make sure that the voltages and currents that are input to the Units and slaves are within the specified ranges. Inputting voltages or currents that are outside of the specified ranges may cause accidents or fire.



Downloading

Always confirm safety at the destination before you transfer a user program, configuration data, setup data, device variables, or values in memory used for CJ-series Units from the Sysmac Studio. The devices or machines may perform unexpected operation regardless of the operating mode of the CPU Unit.



 **Caution**

Application

Do not touch any Unit when power is being supplied or immediately after the power supply is turned OFF. Doing so may result in burn injury.



Wiring

Be sure that all terminal screws and cable connector screws are tightened to the torque specified in the relevant manuals. The loose screws may result in fire or malfunction.



Online Editing

Execute online editing only after confirming that no adverse effects will be caused by deviations in the timing of I/O. If you perform online editing, the task execution time may exceed the task period, I/O may not be refreshed with external devices, input signals may not be read, and output timing may change.



When Using the Temperature Control Unit

To provide for safe operation even in the event of Temperature Control Unit malfunctions, provide safety measures to prevent abnormal temperature rise in a separate system outside the PLC system. If proper safety measures are not taken, serious accidents could result from Unit failure resulting in loss of control.



Do not turn OFF the power supply while set value data is being written to the non-volatile memory in the Temperature Control Unit. Confirm that the Save Completed Flag turns ON after the data write operation has been completed before turning OFF the power supply. If power is turned OFF during a write operation, the data saved in the non-volatile memory may be destroyed.



Precautions for Safe Use

Disassembly and Dropping

- Do not attempt to disassemble, repair, or modify any Units. Doing so may result in malfunction or fire.
- Do not drop any Unit or subject it to abnormal vibration or shock. Doing so may result in Unit malfunction or burning.

Mounting

- The sliders on the tops and bottoms of the Power Supply Unit, CPU Unit, I/O Units, and other Units must be completely locked (until they click into place) after connecting the adjacent Unit connectors.

Installation

- Always connect to a ground of 100 Ω or less when installing the Units. A ground of 100 Ω or less must be installed when shorting the GR and LG terminals on the Power Supply Unit.

Wiring

- Follow the instructions in this manual to correctly perform wiring.
Double-check all wiring and switch settings before turning ON the power supply.
- Use crimp terminals for wiring.
Do not connect bare stranded wires directly to terminals.
- Do not pull on the cables or bend the cables beyond their natural limit.
Do not place heavy objects on top of the cables or other wiring lines. Doing so may break the cables.
- Mount terminal blocks and connectors only after checking the mounting location carefully.
- Be sure that the terminal blocks, expansion cables, and other items with locking devices are properly locked into place.
- Always remove any dustproof labels that are on the top of the Units when they are shipped before you turn ON the power supply. If the labels are not removed, heat will accumulate and malfunctions may occur.
- Before you connect a computer to the CPU Unit, disconnect the power supply plug of the computer from the AC outlet. Also, if the computer has an FG terminal, make the connections so that the FG terminal has the same electrical potential as the GR terminal on the Power Supply Unit. A difference in electric potential between the computer and Controller may cause failure or malfunction.
- If the external power supply to an Output Unit or slave has polarity, connect it with the correct polarity. If the polarity is reversed, current may flow in the reverse direction and damage the connected devices regardless of the operation of the Controller.

Power Supply Design

- Do not exceed the rated supply capacity of the Power Supply Units in the NJ-series Controller. The rated supply capacities are given in the *NJ-series CPU Unit Hardware User's Manual* (Cat. No. W500).
If the capacity is exceeded, operation may stop, malfunctions may occur, or data may not be backed up normally for power interruptions.
Use NJ-series Power Supply Units for both the NJ-series CPU Rack and Expansion Racks.
Operation is not possible if a CJ-series Power Supply Unit is used with an NJ-series CPU Unit or an NJ-series Power Supply Unit is used with a CJ-series CPU Unit.

- Do not apply voltages or connect loads to the Output Units or slaves in excess of the maximum ratings.
- Surge current occurs when the power supply is turned ON. When selecting fuses or breakers for external circuits, consider the above precaution and allow sufficient margin in shut-off performance. Refer to the relevant manuals for surge current specifications. Refer to the *NJ-series CPU Unit Hardware User's Manual* (Cat. No. W500) for surge current specifications.
- If the full dielectric strength voltage is applied or turned OFF using the switch on the tester, the generated impulse voltage may damage the Power Supply Unit. Use the adjustment on the tester to gradually increase and decrease the voltage.
- Apply the voltage between the Power Supply Unit's L1 or L2 terminal and the GR terminal when testing insulation and dielectric strength.
- Do not supply AC power from an inverter or other device with a square-wave output. Internal temperature rise may result in smoking or burning. Always input a sinusoidal wave with the frequency that is given in the *NJ-series CPU Unit Hardware User's Manual* (Cat. No. W500).
- Install external breakers and take other safety measures against short-circuiting in external wiring.

Turning ON the Power Supply

- It takes up to approximately 10 to 20 s to enter RUN mode after the power is turned ON. During that time, outputs will be OFF or will be the values specified in the Unit or slave settings, and external communications cannot be performed. Use the RUN output on the Power Supply Unit, for example, to implement fail-safe circuits so that external devices do not operate incorrectly.
- Configure the external circuits so that the power supply to the control system turns ON only after the power supply to the Controller has turned ON. If the power supply to the Controller is turned ON after the control power supply, temporary errors may result in incorrect control system signals because the output terminals on Output Units may momentarily turn ON when power supply is turned ON to the Controller.
- If you transfer data from a backup file on an SD Memory Card to the Controller when the power supply is turned ON, properly select the data groups to transfer. If the data for an unintended data group is transferred to the Controller, it may cause the equipment to operate unpredictably.

Actual Operation

- Check the user program, data, and parameter settings for proper execution before you use them for actual operation.

Turning OFF the Power Supply

- Never turn OFF the power supply to the Controller when the BUSY indicator is flashing. While the BUSY indicator is lit, the user program and settings in the CPU Unit are being backed up in the built-in non-volatile memory. This data will not be backed up correctly if the power supply is turned OFF. Also, a major fault level Controller error will occur the next time you start operation, and operation will stop.
- Do not turn OFF the power supply or remove the SD Memory Card while SD Memory Card access is in progress (i.e., while the SD BUSY indicator flashes). Data may become corrupted, and the Controller will not operate correctly if it uses corrupted data. To remove the SD Memory Card from the CPU Unit while the power supply is ON, press the SD Memory Card power supply switch and wait for the SD BUSY indicator to turn OFF before you remove the SD Memory Card.
- Do not disconnect the cable or turn OFF the power supply to the Controller when downloading data or the user program from Support Software.
- Always turn OFF the power supply to the Controller before you attempt any of the following.
 - Mounting or removing I/O Units or the CPU Unit
 - Assembling the Units
 - Setting DIP switches or rotary switches

- Connecting cables or wiring the system
- Connecting or disconnecting the connectors

The Power Supply Unit may continue to supply power to the rest of the Controller for a few seconds after the power supply turns OFF. The PWR indicator is lit during this time. Confirm that the PWR indicator is not lit before you perform any of the above.

Operation

- Confirm that no adverse effect will occur in the system before you attempt any of the following.
 - Changing the operating mode of the CPU Unit (including changing the setting of the Operating Mode at Startup)
 - Changing the user program or settings
 - Changing set values or present values
 - Forced refreshing
- Always sufficiently check the safety at the connected devices before you change the settings of an EtherCAT slave or Special Unit.
- If two different function modules are used together, such as when you use CJ-series Basic Output Units and EtherCAT slave outputs, take suitable measures in the user program and external controls to ensure that safety is maintained in the controlled system if one of the function modules stops. The relevant outputs will stop if a partial fault level error occurs in one of the function modules.
- Always confirm safety at the connected equipment before you reset Controller errors with an event level of partial fault or higher for the EtherCAT Master Function Module.
When the error is reset, all slaves that were in any state other than Operational state due to a Controller error with an event level of partial fault or higher (in which outputs are disabled) will go to Operational state and the outputs will be enabled.
Before you reset all errors, confirm that no Controller errors with an event level of partial fault have occurred for the EtherCAT Master Function Module.
- Always confirm safety at the connected equipment before you reset Controller errors for a CJ-series Special Unit. When a Controller error is reset, the Unit where the Controller error with an event level of observation or higher will be restarted.
Before you reset all errors, confirm that no Controller errors with an event level of observation or higher have occurred for the CJ-series Special Unit. Observation level events do not appear on the Controller Error Tab Page, so it is possible that you may restart the CJ-series Special Unit without intending to do so.
You can check the status of the `_CJB_UnitErrSta[0,0]` to `_CJB_UnitErrSta[3,9]` error status variables on a Watch Tab Page to see if an observation level Controller error has occurred.

Battery Backup

- The user program and initial values for the variables are stored in non-volatile memory in the CPU Unit. The present values of variables with the Retain attribute and the values of the Holding, DM, and EM Areas in the memory used for CJ-series Units are backed up by a Battery. If the Battery is not connected or the Battery is exhausted, the CPU Unit detects a Battery-backup Memory Check Error. If that error is detected, variables with a Retain attribute are set to their initial values and the Holding, DM, and EM Areas in memory used for CJ-series Units are cleared to all zeros. Perform thorough verifications and provide sufficient measures to ensure that the devices perform safe operation for the initial values of the variables with Retain attributes and the resulting operation.

Debugging

- Forced refreshing ignores the results of user program execution and refreshes I/O with the specified values. If forced refreshing is used for inputs for which I/O refreshing is not supported, the inputs will first take the specified values, but they will then be overwritten by the user program. This operation differs from the force-set/reset functionality of the CJ-series PLCs.

- You cannot upload or download information for forced refreshing with the Sysmac Studio. After downloading data that contains forced refreshing, change to RUN mode and then use the Sysmac Studio to perform the operation for forced refreshing. Depending on the difference in the forced status, the control system may operate unexpectedly.
- Do not specify the same address for the AT specification for more than one variable. Doing so would allow the same entity to be accessed with different variable names, which would make the user program more difficult to understand and possibly cause programming mistakes.

General Communications

- When you use data link communications, check the error information that is given in *ErrSta* (Controller Error Status) to make sure that no error has occurred in the source device. Write the user program to use the received data only if there is no error. If there is an error in the source device, the data for the data link may contain incorrect values.
- Unexpected operation may result if inappropriate data link tables are set. Even if appropriate data link tables have been set, confirm that the controlled system will not be adversely affected before you transfer the data link tables. The data links start automatically after the data link tables are transferred.
- All CPU Bus Units are restarted when routing tables are transferred from Support Software to the CPU Unit. Confirm that the system will not be adversely affected by restarting before you transfer the routing tables.
- Tag data links will stop between related nodes while tag data link parameters are transferred during Controller operation. Confirm that the system will not be adversely affected before you transfer the tag data link parameters.

EtherNet/IP Communications

- All related EtherNet/IP nodes are reset when you transfer settings for the built-in EtherNet/IP port (including IP addresses and tag data links settings). Confirm that the system will not be adversely affected by resetting nodes before you transfer the settings.
- If EtherNet/IP tag data links (cyclic communications) are used with a repeating hub, the communications load on the network will increase. This will increase collisions and may prevent stable communications. Do not use repeating hubs on networks where tag data links are used. Use an Ethernet switch instead.

EtherCAT Communications

- Make sure that the communications distance, number of nodes connected, and method of connection for EtherCAT are within specifications. Do not connect EtherCAT communications to EtherNet/IP, a standard in-house LAN, or other networks. An overload may cause the network to fail or malfunction.
- Malfunctions or unexpected operation may occur for some combinations of EtherCAT revisions of the master and slaves. If you disable the revision check in the network settings, use the Sysmac Studio to check the slave revision settings in the master and the actual slave revisions, and then make sure that functionality is compatible in the slave manuals or other references. You can check the actual slave revisions from the Sysmac Studio or on slave nameplates.
- After you transfer the user program, the CPU Unit is restarted and communications with the EtherCAT slaves are cut off. During that period, the slave outputs behave according to the slave settings. The time that communications are cut off depends on the EtherCAT network configuration. If the EtherCAT network configuration contains only OMRON EtherCAT slaves, communications are cut off for a maximum of 45 seconds. Before you transfer the user program, confirm that the system will not be adversely affected.

- If the Fail-soft Operation parameter is set to stop operation, process data communications will stop for all slaves when an EtherCAT communications error is detected in a slave. For this reason, if Servo Drives are connected, the Servos for all axes will be turned OFF. Make sure that the Fail-soft Operation parameter setting results in safe operation when a device error occurs.
- EtherCAT communications are not always established immediately after the power supply is turned ON. Use the system-defined variables in the user program to confirm that communications are established before attempting control operations.
- If frames sent to EtherCAT slaves are lost due to noise or other causes, slave I/O data is not communicated, and the intended operation is sometimes not achieved. If noise countermeasures are required, use the `_EC_InDataInvalid` (Input Data Disable) system-defined variable as an interlock condition in the user program.
Refer to the *NJ-series CPU Unit Built-in EtherCAT Port User's Manual* (Cat. No. W505) for details.
The slave outputs behave according to the slave settings. Refer to the manuals for the slaves for details.
- When an EtherCAT slave is disconnected, communications will stop and control of the outputs will be lost not only for the disconnected slave, but for all slaves connected after it. Confirm that the system will not be adversely affected before you disconnect a slave.
- If you disconnect the cable from an EtherCAT slave to disconnect it from the network, any current communications frames may be lost. If frames are lost, slave I/O data is not communicated, and the intended operation is sometimes not achieved. Perform the following processing for a slave that needs to be replaced.
 - Program the `_EC_InDataInvalid` (Input Data Disable) system-defined variable as an interlock condition.
 - Set the Impermissible Number of Continuous Timeouts setting in the EtherCAT master to at least 2.
 Refer to the *NJ-series CPU Unit Built-in EtherCAT Port User's Manual* (Cat. No. W505) for details.

Motion Control

- Confirm the axis number carefully before you perform an MC Test Run.
- The motor is stopped if communications are interrupted between the Sysmac Studio and the CPU Unit during an MC Test Run. Connect the communications cable between the computer and CPU Unit securely and confirm that the system will not be adversely affected before you perform an MC Test Run.
- Always execute the Save Cam Table instruction if you change any of the cam data from the user program in the CPU Unit or from the Sysmac Studio. If the cam data is not saved, the previous condition will be restored when the power is turned ON again, possibly causing unexpected machine operation.
- The positive drive prohibit input (POT), negative drive prohibit input (NOT), and home proximity input (DEC) of the Servo Drive are used by the MC Function Module as the positive limit input, negative limit input, and home proximity input. Make sure that the signal widths for all of these input signals are longer than the control period of the MC Function Module. If the input signal widths are shorter than the control period, the MC Function Module may not be able to detect the input signals, resulting in incorrect operation.

Battery Replacement

- The Battery may leak, rupture, heat, or ignite. Never short-circuit, charge, disassemble, heat, or incinerate the Battery or subject it to strong shock.
- Dispose of any Battery that has been dropped on the floor or otherwise subjected to excessive shock. Batteries that have been subjected to shock may leak if they are used.
- UL standards require that only an experienced engineer replace the Battery. Make sure that an experienced engineer is in charge of Battery replacement.

- Apply power for at least five minutes before changing the Battery. Install a new Battery within five minutes (at 25°C) of turning OFF the power supply. If power is not supplied for at least 5 minutes, the saved data may be lost.

Unit Replacement

- We recommend replacing the Battery with the power turned OFF to prevent the CPU Unit's sensitive internal components from being damaged by static electricity and to prevent malfunctions. The Battery can be replaced without turning OFF the power supply. To do so, always touch a grounded piece of metal to discharge static electricity from your body before you start the procedure. After you replace the Battery, connect the Sysmac Studio and clear the Low Battery Voltage error.
- Make sure that the required data, including the user program, configurations, settings, variables, and memory used for CJ-series Units, is transferred to a CPU Unit that was replaced and to externally connected devices before restarting operation. Be sure to include the routing tables, network parameters, and other CPU Bus Unit data, which are stored in the CPU Unit.

Disposal

- Dispose of the product and Batteries according to local ordinances as they apply.



廢電池請回收

- The following information must be displayed for all products that contain primary lithium batteries with a perchlorate content of 6 ppb or higher when shipped to or transported through the State of California, USA.
Perchlorate Material - special handling may apply.
See www.dtsc.ca.gov/hazardouswaste/perchlorate.
- The CPU Unit contains a primary lithium battery with a perchlorate content of 6 ppb or higher. Place the above information on the individual boxes and shipping boxes when shipping finished products that contain a CPU Unit to the State of California, USA.

When Using the Temperature Control Unit

- To prevent blocking heat distribution, do not block the exterior of the Temperature Control Unit with other object or block the ventilation holes on the Unit.
- Set the parameters of the Temperature Control Unit so that they are appropriate for the system being controlled. Inappropriate settings can lead to unexpected operation, which in turn can damage the product or cause accidents.
- Turn ON the power supply to the load (e.g., heater) at the same time or before turn ON the power supply to the Temperature Control Unit. Optimum control may not be achieved if power is turned ON in the wrong order.
- Do not use the Unit in locations where it will be subject to direct radiant heat from a heater.

Precautions for Correct Use

Storage, Mounting, and Wiring

- Do not operate or store the Controller in the following locations. Operation may stop or malfunctions may occur.
 - Locations subject to direct sunlight
 - Locations subject to temperatures or humidity outside the range specified in the specifications
 - Locations subject to condensation as the result of severe changes in temperature
 - Locations subject to corrosive or flammable gases
 - Locations subject to dust (especially iron dust) or salts
 - Locations subject to exposure to water, oil, or chemicals
 - Locations subject to shock or vibration
- Take appropriate and sufficient countermeasures when installing the Controller in the following locations.
 - Locations subject to strong, high-frequency noise
 - Locations subject to static electricity or other forms of noise
 - Locations subject to strong electromagnetic fields
 - Locations subject to possible exposure to radioactivity
 - Locations close to power lines
- Before touching a Unit, be sure to first touch a grounded metallic object in order to discharge any static build-up.
- Install the Controller away from sources of heat and ensure proper ventilation. Not doing so may result in malfunction, in operation stopping, or in burning.
- An I/O bus check error will occur and the Controller will stop if an I/O Connecting Cable's connector is disconnected from the Rack. Be sure that the connectors are secure.
- Do not allow foreign matter to enter the openings in the Unit. Doing so may result in Unit burning, electric shock, or failure.
- Do not allow wire clippings, shavings, or other foreign material to enter any Unit. Otherwise, Unit burning, failure, or malfunction may occur. Cover the Units or take other suitable countermeasures, especially during wiring work.
- For EtherCAT and EtherNet/IP, use the connection methods and cables that are specified in the *NJ-series CPU Unit Built-in EtherCAT Port User's Manual* (Cat. No. W505) and the *NJ-series CPU Unit Built-in EtherNet/IP Port User's Manual* (Cat. No. W506). Otherwise, communications may be faulty.
- Use the rated power supply voltage for the Power Supply Units. Take appropriate measures to ensure that the specified power with the rated voltage and frequency is supplied in places where the power supply is unstable.
- Make sure that the current capacity of the wire is sufficient. Otherwise, excessive heat may be generated. When cross-wiring terminals, the total current for all the terminals will flow in the wire. When wiring cross-overs, make sure that the current capacity of each of the wires is not exceeded.
- Do not touch the terminals on the Power Supply Unit immediately after turning OFF the power supply. Residual voltage may cause electrical shock.
- If you use reed switches for the input contacts for AC Input Units, use switches with a current capacity of 1 A or greater.
If the capacity of the reed switches is too low, surge current may fuse the contacts.

Error Processing

- In applications that use the results of instructions that read the error status, consider the affect on the system when errors are detected and program error processing accordingly. For example, even the detection of a minor error, such as Battery replacement during operation, can affect the system depending on how the user program is written.
- If you change the event level of a Controller error, the output status when the error occurs may also change. Confirm safety before you change an event level.

Restoring and Automatically Transferring Data

- When you edit the restore command file or the automatic transfer command file, do not change anything in the file except for the “yes” and “no” specifications for the selectable data groups. If you change anything else in the file, the Controller may perform unexpected operation when you restore or automatically transfer the data.

Unit Replacement

- If you replace a CPU Bus Unit or Special I/O Unit, refer to operation manual for the Unit for information on the data required for individual Units and redo the necessary settings.
- The absolute encoder home offset is backed up with a Battery in the CPU Unit.
When you change the combination of the CPU Unit and Servomotor, e.g., when you add or replace a Servomotor, define home again.
To restore the information without changing the CPU Unit-Servomotor combination, remove the absolute encoder home offset from the data to restore.

Task Settings

- If a Task Period Exceeded error occurs, shorten the programs to fit in the task period or increase the setting of the task period.

Motion Control

- Use the system-defined variable in the user program to confirm that EtherCAT communications are established before you attempt to execute motion control instructions. Motion control instructions are not executed normally if EtherCAT communications are not established.
- Use the system-defined variables to monitor for errors in communications with the slaves that are controlled by the motion control function module. Motion control instructions are not executed normally if an error occur in slave communications.
- Before you start an MC Test Run, make sure that the operation parameters are set correctly.
- Do not download motion control settings during an MC Test Run.

EtherCAT Communications

- Do not disconnect the EtherCAT slave cables during operation. The outputs will become unstable.
- Set the Servo Drives to stop operation if an error occurs in EtherCAT communications between the Controller and a Servo Drive.
- Make sure that all of the slaves to be restored are participating in the network before you reset a Network Configuration Verification Error, Process Data Communications Error, or Link OFF Error in the EtherCAT Master Function Module. If any slave is not participating when any of these errors is reset, the EtherCAT Master Function Module may access slave with a different node address than the specified node address or the error may not be reset correctly.

Battery Replacement

- Be sure to install a replacement Battery within two years of the production date shown on the Battery label.
- Turn ON the power after replacing the Battery for a CPU Unit that has been unused for a long time. Leaving the CPU Unit unused again without turning ON the power even once after the Battery is replaced may result in a shorter Battery life.
- When you replace the Battery, use the CJ1W-BAT01 Battery Set.

SD Memory Cards

- Insert the SD Memory Card all the way.
- Do not turn OFF the power supply to the Controller during SD Memory Card access. The files may be corrupted.

If there is a corrupted file in the SD Memory Card, the file is automatically deleted by the restoration function when the power supply is turned ON.

Regulations and Standards

Conformance to EC Directives

Applicable Directives

- EMC Directives
- Low Voltage Directive

Concepts

● EMC Directive

OMRON devices that comply with EC Directives also conform to the related EMC standards so that they can be more easily built into other devices or the overall machine. The actual products have been checked for conformity to EMC standards.*

Whether the products conform to the standards in the system used by the customer, however, must be checked by the customer. EMC-related performance of the OMRON devices that comply with EC Directives will vary depending on the configuration, wiring, and other conditions of the equipment or control panel on which the OMRON devices are installed. The customer must, therefore, perform the final check to confirm that devices and the overall machine conform to EMC standards.

* Applicable EMC (Electromagnetic Compatibility) standards are as follows:

EMS (Electromagnetic Susceptibility): EN 61131-2 and EN 61000-6-2

EMI (Electromagnetic Interference): EN 61131-2 and EN 61000-6-4 (Radiated emission: 10-m regulations)

● Low Voltage Directive

Always ensure that devices operating at voltages of 50 to 1,000 VAC and 75 to 1,500 VDC meet the required safety standards. The applicable directive is EN 61131-2.

● Conformance to EC Directives

The NJ-series Controllers comply with EC Directives. To ensure that the machine or device in which the NJ-series Controller is used complies with EC Directives, the Controller must be installed as follows:

- The NJ-series Controller must be installed within a control panel.
- You must use reinforced insulation or double insulation for the DC power supplies connected to DC Power Supply Units and I/O Units.
- NJ-series Controllers that comply with EC Directives also conform to the Common Emission Standard (EN 61000-6-4). Radiated emission characteristics (10-m regulations) may vary depending on the configuration of the control panel used, other devices connected to the control panel, wiring, and other conditions.

You must therefore confirm that the overall machine or equipment complies with EC Directives.

Conformance to Shipbuilding Standards

The NJ-series Controllers comply with the following shipbuilding standards. Applicability to the shipbuilding standards is based on certain usage conditions. It may not be possible to use the product in some locations. Contact your OMRON representative before attempting to use a Controller on a ship.

Usage Conditions for NK and LR Shipbuilding Standards

- The NJ-series Controller must be installed within a control panel.
- Gaps in the door to the control panel must be completely filled or covered with gaskets or other material.
- The following noise filter must be connected to the power supply line.

Noise Filter

Manufacturer	Model
Cosel Co., Ltd.	TAH-06-683

Trademarks

- Sysmac and SYSMAC are trademarks or registered trademarks of OMRON Corporation in Japan and other countries for OMRON factory automation products.
- Windows, Windows 98, Windows XP, Windows Vista, and Windows 7 are registered trademarks of Microsoft Corporation in the USA and other countries.
- EtherCAT® is registered trademark and patented technology, licensed by Beckhoff Automation GmbH, Germany.
- The SD logo is a trademark of SD-3C, LLC. 

Other company names and product names in this document are the trademarks or registered trademarks of their respective companies.

Unit Versions

Unit Versions

A “unit version” has been introduced to manage CPU Units in the NJ Series according to differences in functionality accompanying Unit upgrades.

Notation of Unit Versions on Products

The unit version is given on the ID information label of the products for which unit versions are managed, as shown below.

Example for NJ-series NJ501-□□□□ CPU Unit:

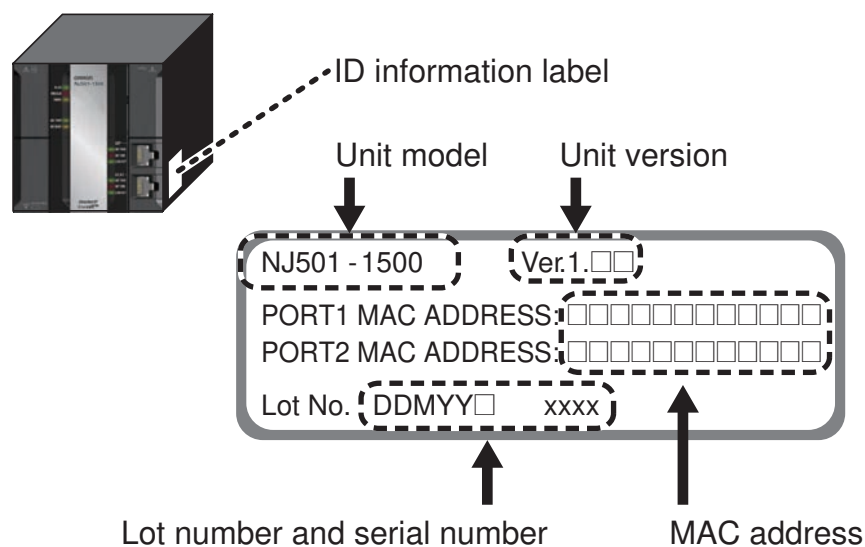

The following information is provided on the ID information label.

Item	Description
Unit model	Gives the model of the Unit.
Unit version	Gives the unit version of the Unit.
Lot number and serial number	Gives the lot number and serial number of the Unit. DDMY□ □: Lot number, □: For use by OMRON, xxxx: Serial number “M” gives the month (1 to 9: January to September, X: October, Y: November, Z: December)
MAC address	Gives the MAC address of the built-in port on the Unit.

Confirming Unit Versions with Sysmac Studio

You can use the Unit Production Information on the Sysmac Studio to check the unit version of the CPU Unit, CJ-series Special I/O Units, CJ-series CPU Bus Units, and EtherCAT slaves. The unit versions of CJ-series Basic I/O Units cannot be checked from the Sysmac Studio.

● CPU Unit and CJ-series Units

- 1 Double-click **CPU/Expansion Racks** under **Configurations and Setup** in the Multiview Explorer. Or, right-click **CPU/Expansion Racks** under **Configurations and Setup** and select **Edit** from the menu.

The Unit Editor is displayed for the Controller Configurations and Setup layer.

- Right-click any open space in the Unit Editor and select **Production Information**.
The Production Information Dialog Box is displayed.

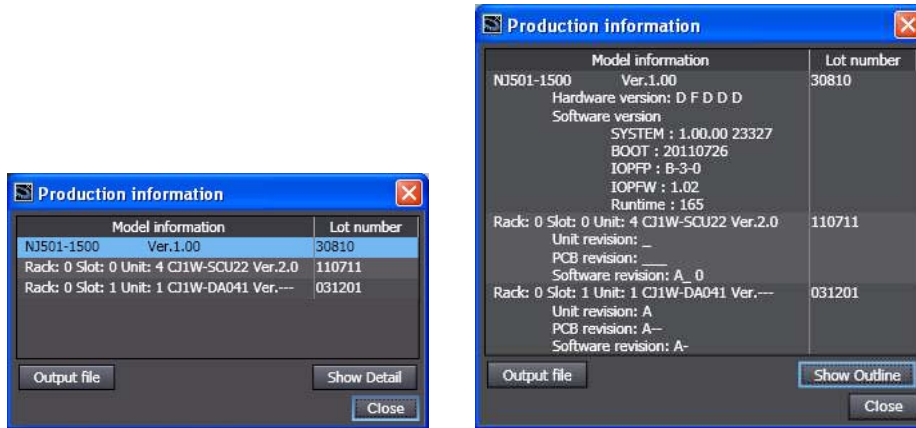

Simple Display

Detailed Display

In this example, "Ver.1.00" is displayed next to the unit model.

The following items are displayed.

CPU Unit	CJ-series Units
Unit model	Unit model
Unit version	Unit version
Lot number	Lot number
	Rack number, slot number, and unit number

● **EtherCAT Slaves**

- Double-click **EtherCAT** under **Configurations and Setup** in the Multiview Explorer. Or, right-click **EtherCAT** under **Configurations and Setup** and select **Edit** from the menu.
The EtherCAT Configuration Tab Page is displayed for the Controller Configurations and Setup layer.
- Right-click the master in the EtherCAT Configurations Editing Pane and select **Display Production Information**.

The Production Information Dialog Box is displayed.

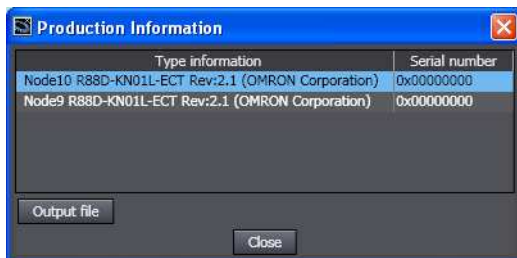

The following items are displayed.

- Node address
- Type information*
- Serial number

* If the model number cannot be determined (such as when there is no ESI file), the vendor ID, product code, and revision number are displayed.

Related Manuals

The following manuals are related to the NJ-series Controllers. Use these manuals for reference.

Manual name	Cat. No.	Model numbers	Application	Description
NJ-series CPU Unit Hardware User's Manual	W500	NJ501-□□□□ NJ301-□□□□	Learning the basic specifications of the NJ-series CPU Units, including introductory information, designing, installation, and maintenance. Mainly hardware information is provided.	An introduction to the entire NJ-series system is provided along with the following information on the CPU Unit. <ul style="list-style-type: none"> • Features and system configuration • Introduction • Part names and functions • General specifications • Installation and wiring • Maintenance and inspection Use this manual together with the <i>NJ-series CPU Unit Software User's Manual</i> (Cat. No. W501).
NJ-series CPU Unit Software User's Manual	W501	NJ501-□□□□ NJ301-□□□□	Learning how to program and set up an NJ-series CPU Unit. Mainly software information is provided.	The following information is provided on a Controller built with an NJ501 CPU Unit. <ul style="list-style-type: none"> • CPU Unit operation • CPU Unit features • Initial settings • Programming based on IEC 61131-3 language specifications Use this manual together with the <i>NJ-series CPU Unit Hardware User's Manual</i> (Cat. No. W500).
Sysmac Studio Version 1 Operation Manual	W504	SYSMAC-SE2□□□	Learning about the operating procedures and functions of the Sysmac Studio.	Describes the operating procedures of the Sysmac Studio.
CJ-series Temperature Control Units Operation Manual for NJ-series CPU Unit (This manual)	W491	CJ1W-TC003/-TC004/-TC103/-TC104	Learning the functions and application methods of the CJ-series Temperature Control Units used in an NJ-series configuration.	Describes the application methods of the CJ-series Temperature Control Units used in an NJ-series configuration.
SYSMAC CJ Series Temperature Control Units Operation Manual	W396	CJ1W-TC□□□	Learning the functions and application methods of the CJ-series Temperature Control Units.	Describes the application methods of the CJ-series Temperature Control Units.

Revision History

A manual revision code appears as a suffix to the catalog number on the front and back covers of the manual.

Cat. No. W491-E1-03

↑
Revision code

Revision code	Date	Revised content
01	July 2011	Original production
02	March 2012	Corrected errors.
03	August 2012	Made changes accompanying release of unit version 1.03 of the CPU Unit.

1

Features and System Configuration

This section describes the features of the Temperature Control Unit and its basic system configuration.

1-1	Introduction and Features	1-2
1-1-1	Introduction	1-2
1-1-2	Features	1-3
1-2	System Configuration	1-7
1-2-1	Basic System Configuration	1-7
1-2-2	Mounting the Unit	1-8

1-1 Introduction and Features

1-1-1 Introduction

This Unit receives inputs directly from thermocouple or platinum resistance thermometers, performs PID control with two degrees of freedom, and outputs results through open collector outputs.

This Unit has two types of inputs: thermocouples (R, S, K, J, T, B, and L) and platinum resistance thermometers (JPt100 and Pt100), and two types of outputs: NPN and PNP.

The Unit also performs Autotuning (AT) of PID constants.

Available Units

I/O type		Output type	
		NPN outputs	PNP outputs
Two control loops (with heater burnout detection function)	Thermocouple	CJ1W-TC003	CJ1W-TC004
	Platinum resistance thermometer	CJ1W-TC103	CJ1W-TC104

Temperature Ranges

Item	Thermocouple										Platinum resistance thermometer		
	K(CA)	K(CA)	J(IC)	J(IC)	T(CC)	L	L	R	S	B	Pt100	JPt100	---
Usable temperature range (°C)	1300 -200	500.0 0.0	850 -100	400.0 0.0	400.0 -200.0	850 -100	400.0 0.0	1700 0	1700 0	1800 100	650.0 -200.0	650.0 -200.0	Settings 2 to 9 are not allowed.
Input Type Switch	0	1	2	3	4	5	6	7	8	9	0	1	2 to 9
Minimum Units	1°C	0.1°C	1°C	0.1°C	0.1°C	1°C	0.1°C	1°C	1°C	1°C	0.1°C	0.1°C	---

K (CA): Chromel-alumel
 J (IC): Iron-constantan
 T (CC): Copper-constantan
 L: Iron-constantan

R: Platinum 13% Rhodium-Platinum
 S: Platinum 10% Rhodium-Platinum
 B: Platinum 30% Rhodium-Platinum 6% Rhodium

Exchange Data with the CPU Unit

Data can be exchanged between the CPU Unit and Temperature Control Unit through the I/O port generated for the Temperature Control Unit.

To connect this Unit to the NJ series, set pin 3 "Data storage/display format" of the DIP switch to ON. (The factory setting is OFF)

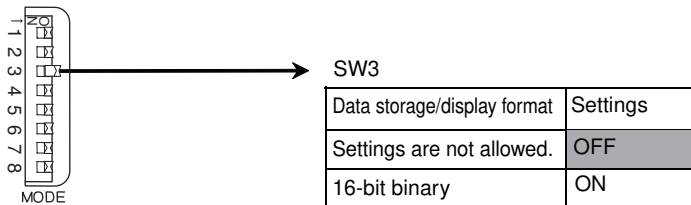

This change becomes effective when the Controller is reset, or when the Unit is restarted.

1-1-2 Features

● Use ON/OFF Control or PID Control with 2 Control Loops

The Temperature Control Unit can perform basic ON/OFF control as well as PID control of two control loops. The PID control function has two degrees of freedom and an autotuning function that can be used to autotune the PID value.

● Connect Temperature Sensors Directly

Temperature sensors can be connected directly to the Temperature Control Unit (two inputs). There are two models that support thermocouples (R, S, K, J, T, B, and L thermocouples) and two models that support platinum resistance thermometers.

● 500-ms Sampling Cycle

PID control is performed with a sampling cycle of 500 ms.

● RUN/STOP Control from CPU Unit

Commands can be sent from the CPU Unit to switch the Temperature Control Unit's PID control between RUN and STOP.

● Independent Operation in PROGRAM Mode

A switch on the front of the Unit (pin 1 of the DIP switch) selects whether the Temperature Control Unit will continue operation or stop when the CPU Unit is in PROGRAM mode.

● Terminal Block Connections

Both inputs and outputs are connected through a terminal block.

● Select ON/OFF Control or PID Control

A switch on the front of the Unit (pin 6 of the DIP switch) selects whether the Temperature Control Unit operates with ON/OFF control or PID control with 2 degrees of freedom.

Note The setting on pin 6 sets the control method for all of the Unit's control loops. The factory setting is PID control.



Additional Information

- ON/OFF Control

With ON/OFF control, the control output will be ON when the PV is below the SV. The control output will be OFF when the PV is at or above the SV. (This control method is used when the Unit is set for reverse operation.)

- PID Control with Two Degrees of Freedom

In earlier versions of PID control, the same controller section controlled both the response to the SV and the response to disturbances. The weakness in this design was that both responses could not be satisfied at the same time.

- 1** If the disturbance response was emphasized (i.e., P and I were reduced and D was increased), the SV response would oscillate and overshoot.
- 2** If the SV response was emphasized (i.e., P and I were increased and D was reduced), the disturbance response would be delayed.

To overcome these problems, PID control with two degrees of freedom was used for this Temperature Control Unit to take advantage of the strengths of PID control and improve both disturbance and target response as shown in 3 below.

Earlier PID Control Method

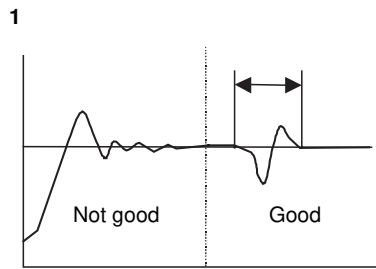

The disturbance response is good, but the SV response is delayed.

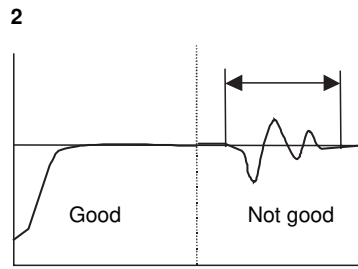

The SV response is good, but the disturbance response is not.

PID Control with Two Degrees of Freedom

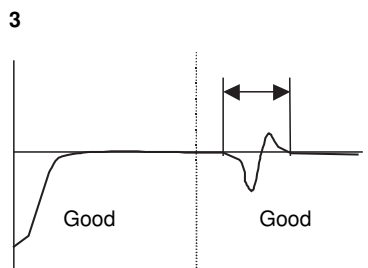

Both the SV response and disturbance response are good.

Autotuning (AT) Function

The Temperature Control Unit is equipped with an autotuning (AT) function that uses the "limit-cycle method" to calculate the optimum PID constant for the controlled system. (The SV cannot be written for a loop if the loop is being autotuned.)

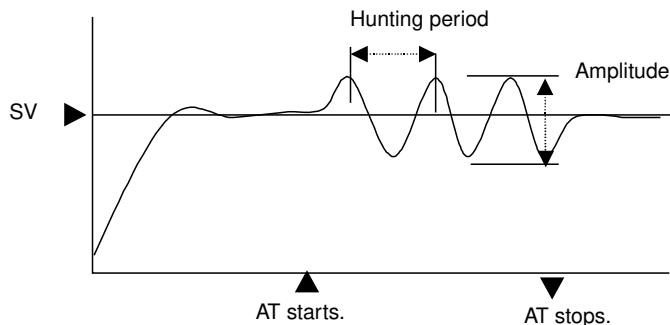

Note The "limit-cycle method" uses ON/OFF operation to cause hunting around the SV, measures the amplitude and hunting period, and calculates the optimum PID constants.

● Control Operation (Forward and Reverse)

The Temperature Control Unit's control can be set to reverse operation or forward operation with pins 4 and 5 of the Unit's DIP switch. The factory setting is for reverse operation (heating).

One forward/reverse setting controls the operation of loop 1, and the other forward/reverse setting controls the operation of loop 2.

Note With forward operation (cooling), the manipulated variable is increased as the PV increases. With reverse operation (heating), the manipulated variable is increased as the PV decreases.

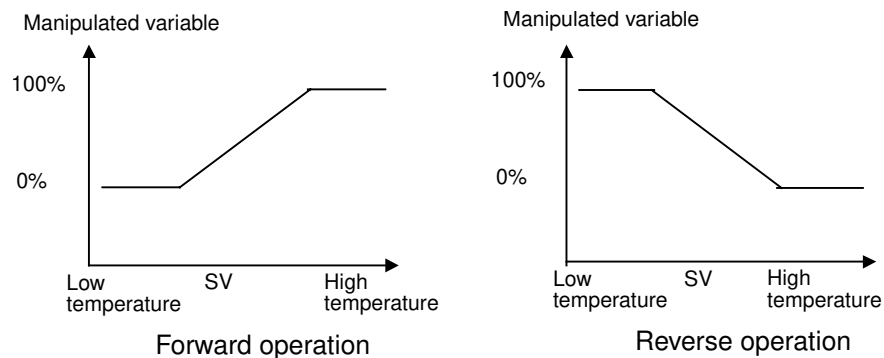

For example, when heating control is being performed and the process value (PV) is lower than the set point (SP), the manipulated variable is increased as the difference between the PV and SP increases. Consequently, heating control uses "reverse operation" and cooling control uses "forward operation."

● Input Compensation Function

This function adjusts the PV by adding an input compensation value to the temperature measured by the sensor.

If you have an application where you want to control and display the temperature at a point that is offset from the sensor's measurement point, use this function to control the temperature at a value near the desired point.

● Heater Burnout Detection (Single-phase Operation Only)

A Current Transformer (CT) can be connected to each loop to detect a heater burnout.

● Two Internal Alarms for Each Loop

There are two internal alarms per loop. Alarms can be output to the device variables for CJ-series Unit in the CPU Unit's memory areas and any one of the following 9 alarm modes can be used:

Upper and lower-limit alarm, upper-limit alarm, lower-limit alarm, upper and lower-limit alarm with standby sequence, upper-limit alarm with standby sequence, lower-limit alarm with standby sequence, absolute-value upper-limit alarm, and absolute-value lower-limit alarm

● Store Set Values in Non-volatile Memory

Various Temperature Control Unit set values, such as the alarm SVs and PID constants, can be stored in the Unit's non-volatile memory using device variables for CJ-series Unit.

Also, it is possible to set the Temperature Control Unit so that the set values stored in non-volatile memory are automatically written to the device variables for CJ-series Units when the power is turned ON or the Unit is restarted (pin 8 of the DIP switch on the front panel of the Temperature Control Unit).

Once the set values have been stored in the Temperature Control Unit and the Unit is set for automatic transfer, the Unit will always start with those settings whether the power has been turned OFF or not. (The set values can be changed after startup if necessary.)

To simplify Temperature Control Unit operation, pin 8 of the DIP switch can be turned ON to enable operation by merely turning ON the power supply and setting Operation Data (the SP). All other settings can be used at their factory settings. (Refer to *2-6 Range of Set Values and Monitor Values* for the default settings.)

1-2 System Configuration

⚠ Caution

To provide for safe operation even in the event of Temperature Control Unit malfunctions, provide safety measures to prevent abnormal temperature rise in a separate system outside the PLC system.

If proper safety measures are not taken, serious accidents could result from Unit failure resulting in loss of control.



1-2-1 Basic System Configuration

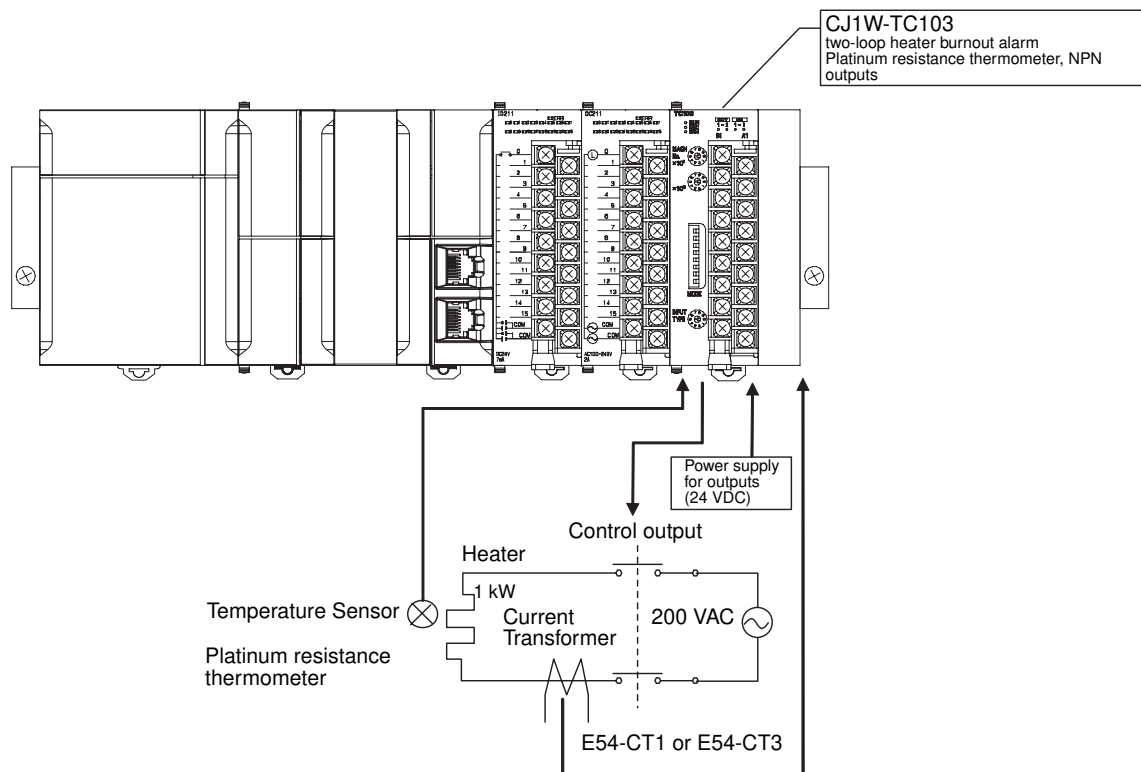

- Note 1** The above diagram shows an example of the platinum resistance thermometer with two-loop heater burnout alarm, and NPN outputs (CJ1W-TC103) mounted.
- 2** An OMRON E54-CT1 or E54-CT3 Current Transformer must be used as the Current Transformer (CT). Do not use any other Current Transformer.
- 3** Turn ON the Stop Bit for the loop to stop temperature control. If PID control is being used and the heater is turned OFF using an operation switch input to the heater, PID control performance will be adversely affected.

1-2-2 Mounting the Unit

This Unit is a Special I/O Unit of the NJ series.

You can mount the Unit to a CPU Rack or expansion Rack of the NJ series.

The number of Units that can be mounted in a CPU Rack or Expansion Rack depends on the capacity of the Rack's Power Supply Unit and the current consumption of the other Units in the Rack.

The following table shows the maximum number of CJ1W-TC□□□ Temperature Control Units that can be mounted in a Rack if the Temperature Control Units are the only Units being used in the Rack.

Power Supply Unit	CJ1W-TC□□□
CJ1W-PA205R	10 Units

Installation Procedure

Use the following procedure to install the Temperature Control Unit. The PLC must be removed from the DIN Track in order to connect a Temperature Control Unit.

- 1 Align the Units and connect them together so that the connectors join smoothly and completely.

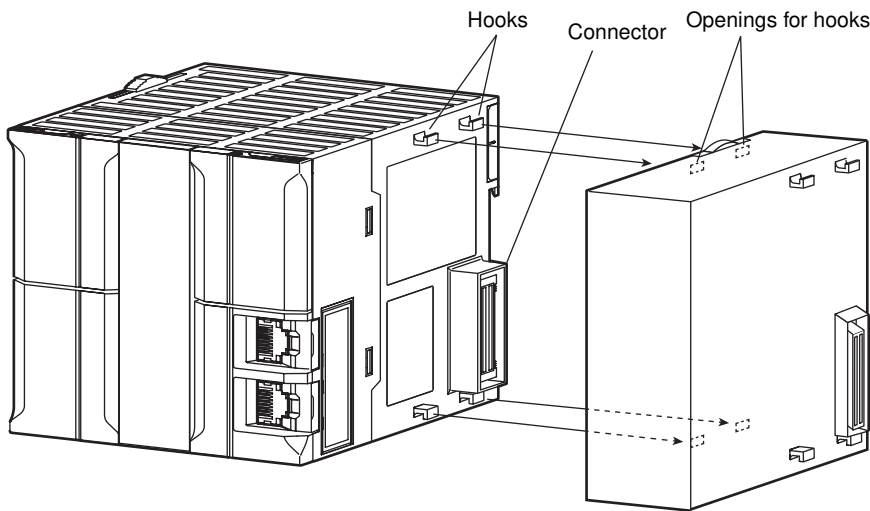

- 2 Slide the yellow latches on the top and bottom of the Unit until you hear the latches click and lock the Units together.

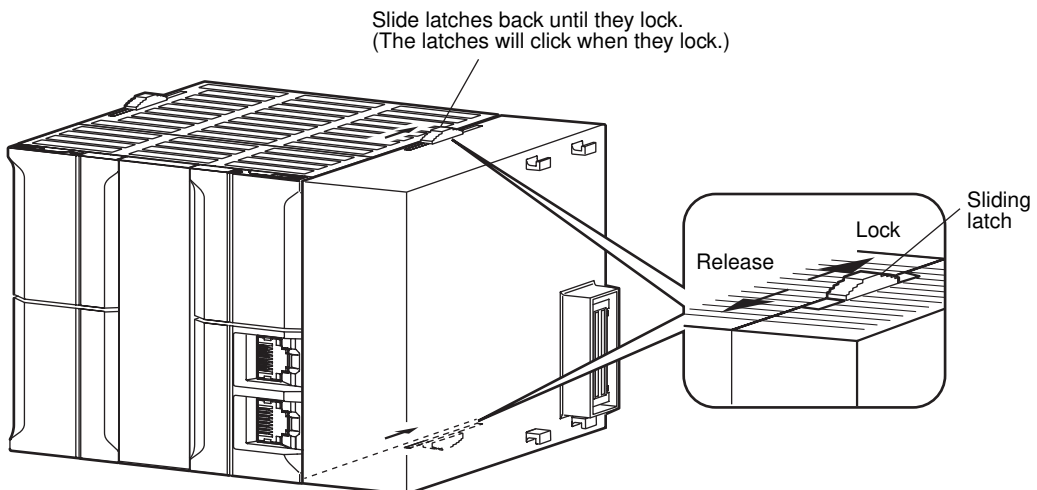

- 3 Install an End Cover on the rightmost Unit.

**Precautions for Safe Use**

The Unit's functions may not be completely operational if the sliders are not locked securely.

**Precautions for Correct Use**

An End Cover is provided with the CPU Unit. Always install this End Cover on the rightmost Unit in the PLC. The NJ-series PLC will not operate properly if the End Cover is not installed.

Handling Precautions

- Always turn OFF the controller's power supply before connecting or disconnecting wiring to the Unit.
- To avoid problems with noise, route the I/O wiring in a separate duct or conduit that does not carry any high-voltage lines or power lines.
- Prevent wire clippings, cutting chips or other materials from getting inside the Unit. They could cause scorching, failure, and malfunction. Pay particular attention to this during installation and take measures such as covering with a cover.
- If the Unit was shipped from the factory with the dust protection label on top of the unit, be sure to remove that label before switching ON the power. The label prevents heat dissipation and could cause a malfunction.

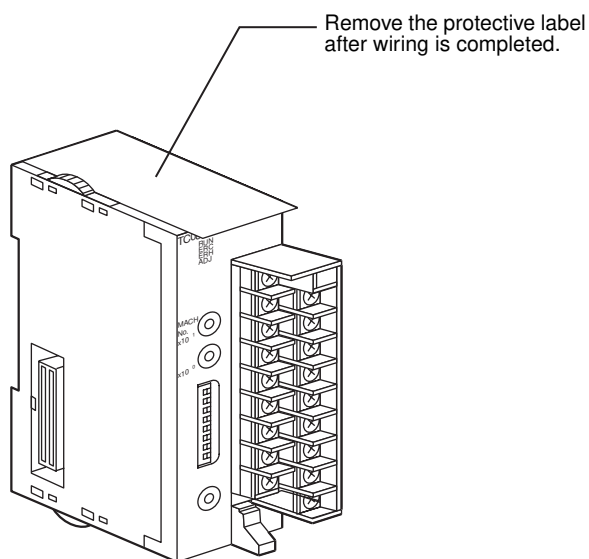

Precautions on Removable Terminal Blocks

The terminal block can be removed by pressing down on the lever at the bottom of the terminal block. Always confirm that this lever is up in the locked position before starting operation.



Precautions for Correct Use

A cold junction sensor is attached to the terminal block for Temperature Control Units with thermocouples. The accuracy ratings are given for the Temperature Control Unit used in a set with the cold junction sensor. Always use the Unit and terminal block in a set. There are labels with serial numbers attached to the terminal blocks and Units to help keep track of the sets.

When returning a thermocouple-type Temperature Control Unit for repair, always return the Unit and the terminal block (with the cold junction sensor) as a set.

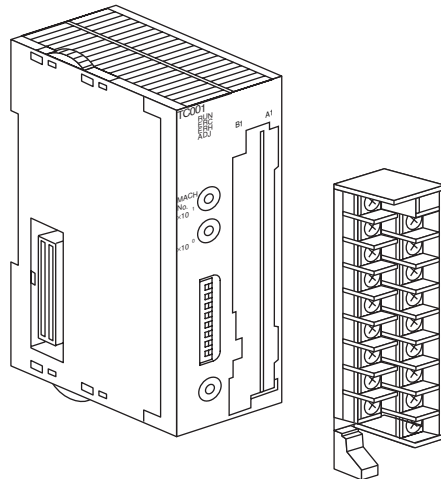

2

Specifications and Functions

This section describes the functions and specifications of the Temperature Control Unit, including technical specifications, Unit parts, wiring, and data allocations.

2-1	Specifications	2-2
2-1-1	Specifications	2-2
2-1-2	Input Function Block Diagram	2-5
2-1-3	Input Specifications	2-5
2-2	Application Procedure	2-7
2-3	Part Names and Functions	2-11
2-3-1	Part Names	2-11
2-3-2	Indicators	2-11
2-3-3	Unit Number Switches	2-12
2-3-4	DIP Switch Setting Functions	2-13
2-3-5	Input Type Switch	2-15
2-4	Wiring	2-16
2-4-1	Terminal Wiring Examples	2-16
2-4-2	Output Circuits	2-17
2-4-3	I/O Wiring Examples	2-18
2-5	Data Exchange with the CPU Unit	2-21
2-5-1	Overview	2-21
2-5-2	Accessing from the User Program	2-22
2-5-3	Saving Set Value in the Non-volatile Memory	2-23
2-5-4	Operation Data	2-24
2-5-5	Initialization Data	2-30
2-5-6	Operating Parameters	2-32
2-6	Range of Set Values and Monitor Values	2-35
2-6-1	Set Values	2-35
2-6-2	Monitor Values	2-37

2-1 Specifications

2-1-1 Specifications

General Specifications

Item	Specification
Unit classification	NJ-series Special I/O Unit
Compatible Racks	NJ-series CPU Rack or NJ-series Expansion Rack
Max. number of Units	10 Units/Rack max. (CPU Rack or Expansion Rack)
Methods of exchanging data with CPU	Data exchange by using I/O ports Refer to <i>2-5 Data Exchange with the CPU Unit</i>
Insulation resistance	20 MΩ min. (at 500 VDC) between the following points: <ul style="list-style-type: none"> • Output terminals/NC terminals and external AC terminals (Power Supply Unit) • Input terminals and external AC terminals (Power Supply Unit) • Input terminals and output terminals • External DC terminals (inputs, outputs, and NC) and the FG plate • Between input terminals (sensor and CT inputs) • Between the I/O terminals and NC terminals
Dielectric strength	2,000 VAC 50/60 Hz for 1 min., detected current: 1 mA <ul style="list-style-type: none"> • Between the output terminals/NC terminals and external AC terminals (Power Supply Unit) 1,000 VAC 50/60 Hz for 1 min., detected current: 1 mA <ul style="list-style-type: none"> • Input terminals and external AC terminals (Power Supply Unit) • Input terminals and output terminals • External DC terminals (inputs, outputs, and NC) and the FG plate 500 VAC 50/60 Hz for 1 min., detected current: 1 mA <ul style="list-style-type: none"> • Between input terminals (sensor and CT inputs) • Between the I/O terminals and NC terminals
Internal current consumption	250 mA max., 5 VDC
Other	Other general specifications conform to the NJ-series general specifications.
Dimensions	31 × 90 × 65 mm (W × H × D)
Weight	150 g max.

Characteristics

Item	Specification
Model number	CJ1W-TC003/TC004 CJ1W-TC103/TC104
Temperature sensor	Thermocouple: Types R, S, K, J, T, L, and B Platinum resistance thermometer: Types Pt100 and JPt100
Number of loops	There are two types of Unit available: Two-loop Unit with heater burnout detection. *1
Control output and heater burnout alarm output	NPN or PNP outputs, both with short-circuit protection*1 Externally supplied power supply voltage: 24 VDC +10%/-15% Maximum switching capacity: 100 mA (per output) Leakage current: 0.3 mA max. Residual voltage: 3 V max.
Temperature control method	ON/OFF control or PID control with two degrees of freedom (Set with pin 6 on the Unit's DIP switch.)
Control operation	Forward or reverse operation (Set with pins 4 and 5 on the Unit's DIP switch.)

Item	Specification	
RUN/STOP control	Supported (Controlled from the CPU Unit through the device variable for CJ-series Unit.)	
Operation with CPU Unit in PROGRAM mode	The Temperature Control Unit can be set to continue operating or stop operating when the CPU Unit is in PROGRAM mode. (Set with pin 1 on the Unit's DIP switch.)	
Auto/Manual switch for operational output	None	
Autotuning (AT) of PID constant	Supported (Controlled from the CPU Unit through the device variable for CJ-series Unit.)	
Indication accuracy	Centigrade: $\pm 0.3\%$ PV or $\pm 1^\circ\text{C}$ (whichever is larger) ± 1 digit max. Fahrenheit: $\pm 0.3\%$ PV or $\pm 2^\circ\text{F}$ (whichever is larger) ± 1 digit max. • The accuracy will be $\pm 2^\circ\text{C} \pm 1$ digit max. when using an L-type thermocouple or using a K or T-type thermocouple below -100°C . • The accuracy will be $\pm 3^\circ\text{C} \pm 1$ digit max. when using an R or S-type thermocouple below 200°C . • The B-type thermocouples may not be accurate below $400^\circ\text{C} \times 2$	Centigrade: $\pm 0.3\%$ PV or $\pm 0.8^\circ\text{C}$ (whichever is larger) ± 1 digit max. Fahrenheit: $\pm 0.3\%$ PV or $\pm 1.6^\circ\text{F}$ (whichever is larger) ± 1 digit max.
Warmup time	30 min	
Sensitivity (when using ON/OFF control)	0.0 to 999.9 $^\circ\text{C}$ or $^\circ\text{F}$ (0.1 $^\circ\text{C}$ or $^\circ\text{F}$ units)	
Proportional band	0.1 to 999.9 $^\circ\text{C}$ or $^\circ\text{F}$ (0.1 $^\circ\text{C}$ or $^\circ\text{F}$ units)	
Integral (reset) time	0 to 9,999 s (one-second units)	
Derivative (rate) time	0 to 9,999 s (one-second units)	
Control period	1 to 99 s (one-second units)	
Sampling period	500 ms (2 loops)	
Output refresh period	500 ms (2 loops)	
Display refresh period	500 ms (2 loops)	
Input compensation value	-99.9 to 999.9 $^\circ\text{C}$ or $^\circ\text{F}$ (0.1 $^\circ\text{C}$ or $^\circ\text{F}$ units)	
Alarm output setting range	-999 to $9,999$ $^\circ\text{C}$ or $^\circ\text{F}$ (1 $^\circ\text{C}$ or $^\circ\text{F}$ units) The setting range will be -99.9 to 999.9 $^\circ\text{C}$ or $^\circ\text{F}$ (0.1 $^\circ\text{C}$ or $^\circ\text{F}$ units) when using a platinum resistance thermometer or using a K or J-type thermocouple in decimal-point mode.	
External terminal connections	Removable terminal block with 18 points (M3 screws)	

*1 The last three digits of the model number indicate the Unit's features:

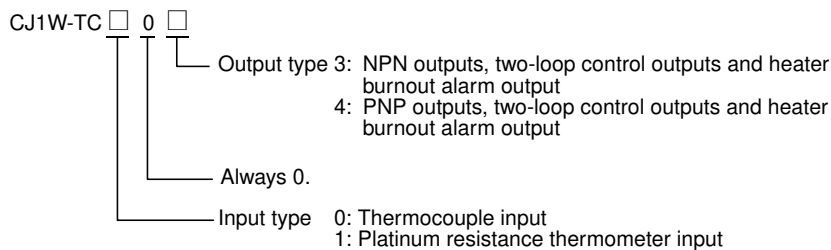

*2 Indication accuracy of thermocouples

- Accuracy ratings are given for the Temperature Control Unit used in a set with a cold junction sensor (on the terminal block). Always use the Unit and terminal block in a set. There are labels with serial numbers attached to the terminal blocks and Units to help keep track of the sets.
- When returning a thermocouple-type Temperature Control Unit for repair, always return the Unit and the terminal block (with the cold junction sensor) as a set.

Heater Burnout (HB) Alarm

Item	Specification
Maximum heater current	Single-phase AC, 50 A
Indication accuracy of input current	±5% of full scale ± 1 digit max.
Heater burnout alarm setting range	0.1 to 49.9 A (0.1 A units) The heater burnout detection function will not operate if the set value is set to 0.0 A or 50.0 A. (When the SV is 0.0 A, the heater burnout alarm will be OFF. When the SV is 50.0 A, the heater burnout alarm will be ON.)
Min. detectable ON time*	200 ms

* If the control output is ON for less than 200 ms, the heater burnout detection function will not operate and heater current measurement will not be performed.

Current Transformer (CT) Ratings

Item	E54-CT1	E54-CT3
Max. continuous heater current	50 A	120 A*
Dielectric strength	1,000 VAC (1 min)	
Vibration resistance	50 Hz, 98 m/s ²	
Weight	Approx. 11.5 g	Approx. 50 g
Accessories	None	Contacts (2) Plugs (2)

* The maximum continuous heater current that can be detected at a CJ1W-TC□□□ Temperature Control Unit is 50 A.

Note Do not use any Current Transformer (CT) other than the OMRON E54-CT1 or E54-CT3 Current Transformer.

2-1-2 Input Function Block Diagram

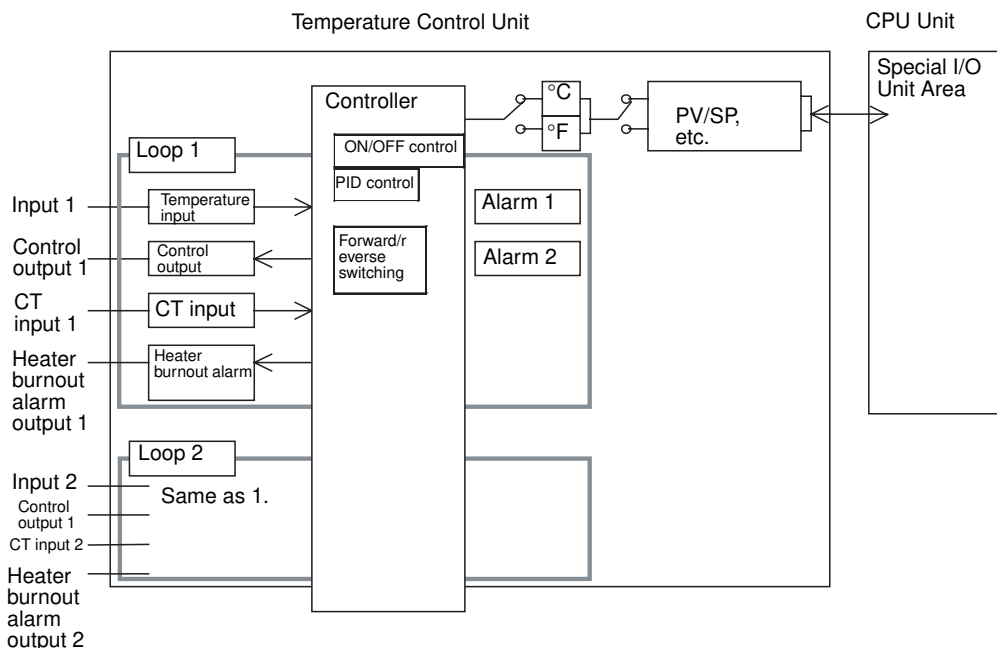

2-1-3 Input Specifications

Pin 2 of the DIP switch selects whether the temperature is indicated in °C or °F. The indicated range will be within $\pm 20^{\circ}\text{C}$ or $\pm 20^{\circ}\text{F}$ of the setting ranges shown in the following table. If the allowed indication range is exceeded, a sensor error will occur. The corresponding sensor error bit will be turned ON and the PV (process value) will contain the data "-13108". When a sensor error occurs, that control loop's control output will be turned OFF. The alarm function will operate because the PV indicates an abnormally high temperature.

Thermocouple Input Setting Ranges

Sensor	Set value	Input type	Temperature range
Thermocouple	0	K	-200 to 1300°C/-300 to 2300°F
	1		0.0 to 500.0°C/0.0 to 900.0°F
	2	J	-100 to 850°C/-100 to 1500°F
	3		0.0 to 400.0°C/0.0 to 750.0°F
	4	T	-200.0 to 400.0°C/-300.0 to 700.0°F
	5	L	-100 to 850°C/-100 to 1500°F
	6		0.0 to 400.0°C/0.0 to 750.0°F
	7	R	0 to 1700°C/0 to 3000°F
	8	S	0 to 1700°C/0 to 3000°F
9	B*	100 to 1800°C/300 to 3200°F	

* The lower-limit indication for B-type thermocouples is 0°C or 0°F.

Note When the Input Type Switch has been changed, the SV and input compensation values will change as follows:

- If the SV exceeds the setting range, it will be fixed at the lower limit or upper limit of the setting range.
- The position of the decimal point will change if necessary.

For example, when the temperature range is changed by changing the Input Type Switch from 0 (K-type thermocouple with a temperature range of -200 to $1,300^{\circ}\text{C}$) to 1 (K-type thermocouple with a temperature range of 0.0 to 500.0°C), an SV of 200°C will be changed to 20.0°C .

Platinum Resistance Thermometer Input Setting Ranges

Sensor	Set value	Input type	Temperature range
Platinum Resistance Thermometer	0	Pt100	-200.0 to 650.0°C / -300.0 to 1200.0°F
	1	JPt100	-200.0 to 650.0°C / -300.0 to 1200.0°F
	2 to 9		Do not set 2 through 9.

2-2 Application Procedure

The procedure for installing and setting up the Temperature Control Unit is illustrated below. Use Sysmac Studio to create and set programs.

For operations of Sysmac Studio, refer to the *Sysmac Studio Version 1 Operation Manual* (Cat. No. W504).

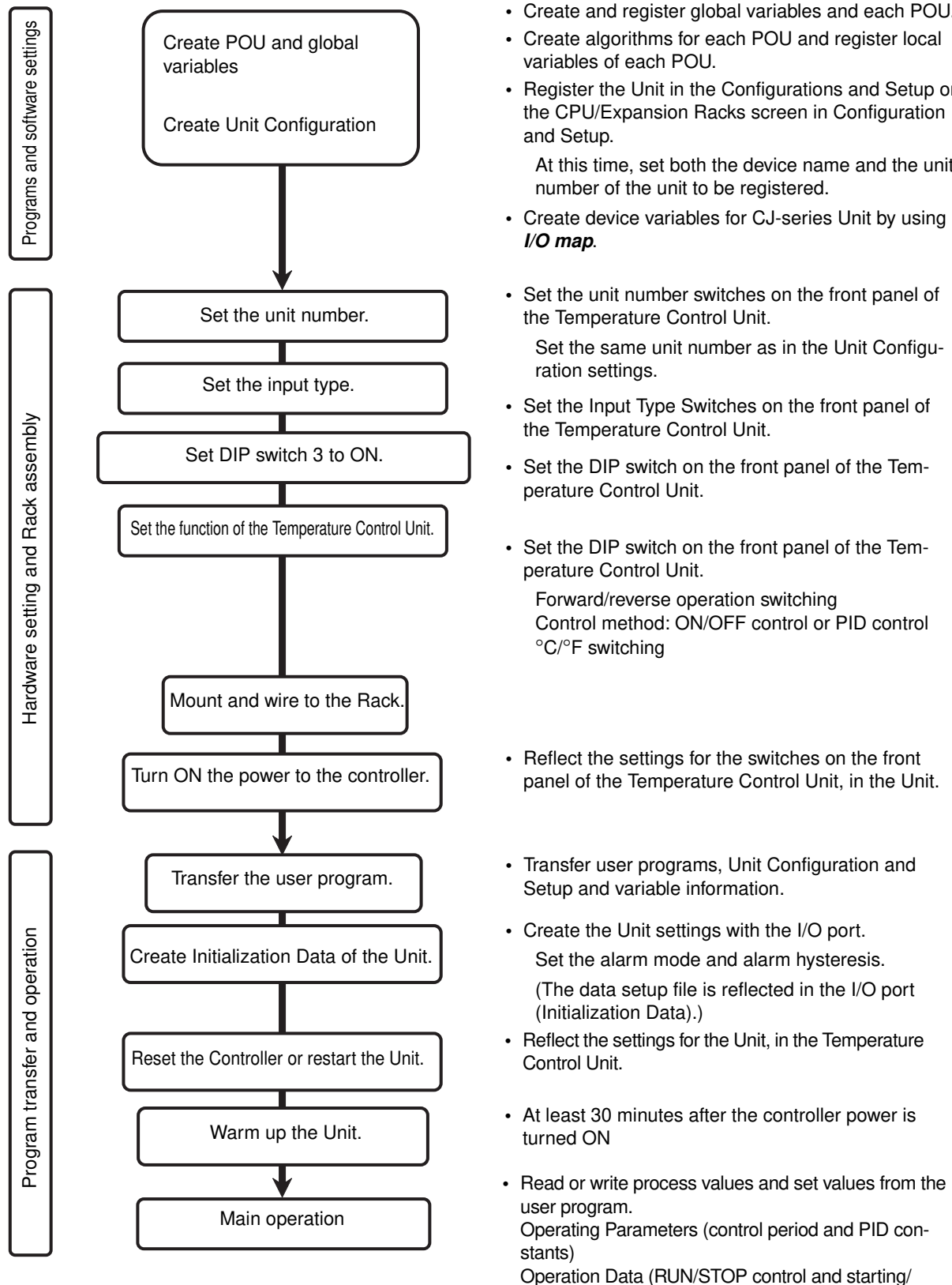



Precautions for Safe Use

- When you change the unit settings and reset the Controller or restart the Unit, be sure to first properly check the safety of the devices at the connection destination.
- Warm up the Unit for at least 30 minutes to ensure accurate operation. The indicated temperature error will be larger if the Unit is not warmed up.

Example Operating Procedure

The following settings are used in this example for a Two-loop Temperature Control Unit.

Input type: Thermocouple

Input: K thermocouple (0.0 to 500.0 °C)

In this example, the device name "J01" is used when this Unit is registered in Unit Configuration.

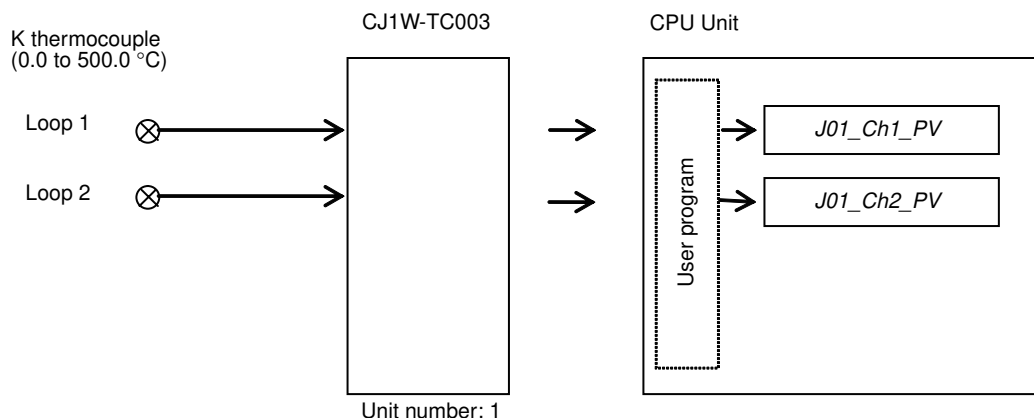

● Create Unit Configuration

Use Sysmac Studio to create Unit Configuration. Place the Temperature Control Unit in slot 0 on the CPU Rack.

When this Unit is registered in the Unit Configuration, the device name is entered as "J01". For details on creation of Unit Configuration, refer to the *Sysmac Studio Version 1 Operation Manual* (Cat. No. W504).

● Creating User Programs

The process value (PV) of each loop (*J01_Ch#_PV*) are stored in the data storage destination of the user-defined variable (*Temperature#*).

Each input value is read when the Sensor Error Flag of each loop is OFF.

● Variable

Variable names	Variable type	Description	Type
J01_Ch1_PV	Device variable for CJ-series Unit *1	Loop 1 Process Value	INT
J01_Ch2_PV		Loop 2 Process Value	INT
J01_Ch1_SensErr		Loop 1 Sensor Error Flag	BOOL
J01_Ch2_SensErr		Loop 2 Sensor Error Flag	BOOL
Temperature1	User-defined variable *2	Loop 1 PV Data Storage Destination	INT
Temperature2		Loop 2 PV Data Storage Destination	INT

- *1 Device variables for CJ-series Unit are created using the *I/O map* from the Sysmac Studio.
- *2 Before you create the user program, use Sysmac Studio to create user-defined variables.

● Example of program

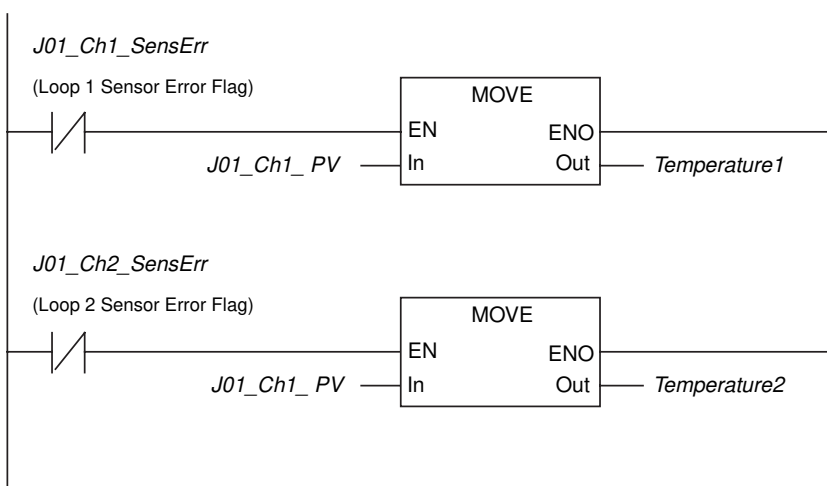

● Settings

- 1 Set the Unit number referring to 2-3-3 Unit Number Switches. If the unit number is set to 1.

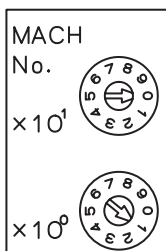

- 2 Set the input type referring to 2-3-5 Input Type Switch. Set the switch on the front panel of the Unit to 1 for a K thermocouple (0.0 to 500.0 °C).

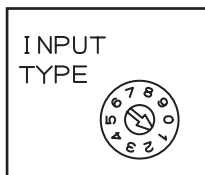

- 3** Set the Unit's functions referring to *2-3-4 DIP Switch Setting Functions*. Be sure that pin 2 is OFF to select centigrade and that pin 3 (Data storage/display format) is ON to select BCD.



- 4** Mount and wire the Unit, referring to *1-2-2 Mounting the Unit*.
- 5** Turn ON the power supply to the controller.



Precautions for Safe Use

Always turn OFF the power supply to the Controller before attempting any of the following.

- Mounting or dismounting I/O Units or CPU Unit.
- Assembling the Units.
- Setting DIP switches or rotary switches.
- Connecting cables or wiring the system.

After the power is turned OFF, the Power Supply Unit may continue to supply power to the Controller for a few seconds. During that time the PWR indicator remains lit. When performing any of the above operations, check that the PWR indicator does not lit.



Additional Information

An I/O Setting Check Error occurs when there is a Unit Configuration in the CPU Unit which does not match the actual Unit Configuration. In this case, reset the Controller in step 2 of the following *Transfer a User Program to a CPU Unit* process to cancel the error.

● Transfer a User Program to a CPU Unit

- 1** Connect Sysmac Studio to the Controller and transfer the created user program.
- 2** Reset the Controller. (Or restart this Unit.)
- 3** Run with the created user program.

2-3 Part Names and Functions

2-3-1 Part Names

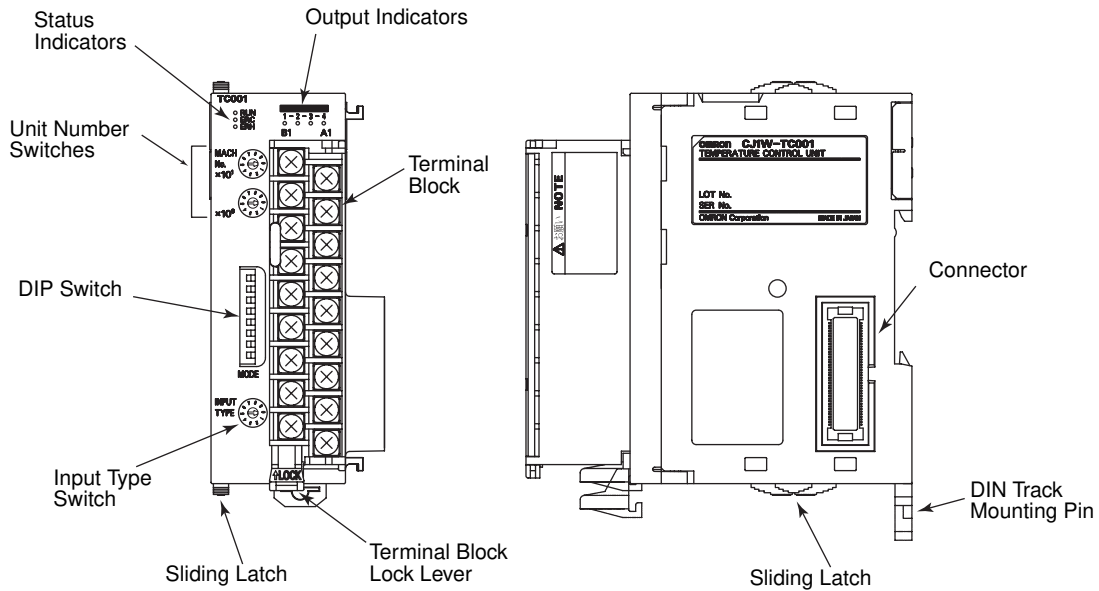

2-3-2 Indicators

Status Indicators

The Status Indicators indicate the operating status of the Temperature Control Unit, as explained in the following table.

Indicator	Name	Color	Status	Meaning
RUN	RUN Indicator	Green	Lit	Normal operating status
			Not lit	Temperature control is stopped.
ERC	Temperature Control Unit Error	Red	Lit	An error occurred in the Temperature Control Unit itself, such as a Sensor Error or Initialization Error.
			Not lit	Normal operating status
ERH	CPU Unit Error	Red	Lit	An error occurred in the CPU Unit.
			Not lit	Normal operating status

Output Indicators

The Output Indicators light to indicate when the corresponding Temperature Control Unit output is ON.

2-3-3 Unit Number Switches

Use the unit number switches to set the specific unit number for each Special I/O Unit mounted in a CPU Rack or Expansion Rack. The unit number must be the one registered in Unit Configurations.

Set the unit number between 0 and 94. One Temperature Control Unit occupies two unit numbers, and consecutive unit numbers cannot be set for Temperature Control Units.

Turn OFF the Controller before setting the unit number. (For details on the correlation of the unit number and allocated memory, refer to *A-3 Correspondence Table of Device Variables for CJ-series Unit and Memory Used for CJ-series Unit Addresses*.)

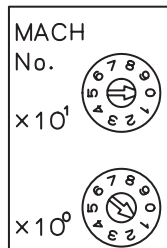

Precautions for Correct Use

If two or more Special I/O Units are assigned the same unit number, a major fault level Controller error "Duplicate Unit Number" will be generated and the PLC will not operate.

After correcting the unit number setting, cycle the power to the controller.

2-3-4 DIP Switch Setting Functions



ON is to the right.

Turn OFF the Controller before setting the unit number.

Unit settings are reflected when the Unit restarts or the Controller is reset, including when the power is turned ON.

Pin	Function	ON	OFF	Factory setting
1	Operation when CPU Unit is in PROGRAM mode	Continue	Stop	OFF
2	Temperature units (°C/°F)	°F	°C	
3	Data storage/display format	Set to ON for use.		
4	Control operation (for loop 1)	Forward (cooling)	Reverse (heating)	
5	Control operation (for loop 2)	Forward (cooling)	Reverse (heating)	
6	Control method	ON/OFF control	PID control	
7	Initialize set values in Non-volatile Memory	Initialize	Do not initialize	
8	Transfer set values in Non-volatile Memory	Transfer	Do not transfer	ON

Operation in PROGRAM mode (Pin 1)

The following table shows how the Temperature Control Unit will operate when the CPU Unit's operating mode is changed.

Temperature Control Unit settings		Operation of Temperature Control Unit when CPU Unit's operating mode is changed	
Pin 1	Stop Bit	From RUN to PROGRAM	From PROGRAM to RUN
OFF (Stop)	Run	Stop operation	Continue operation
	Stop	Stop operation	Stop operation
ON (Continue)	Run	Continue operation	Continue operation
	Stop	Stop operation	Stop operation

Temperature Units (Pin 2)

Select either °C display (centigrade) or °F display (fahrenheit). When °F is selected, the temperature is converted using the following equation:

$$°F = (°C \times 1.8) + 32$$

Data Storage/Display Format (Pin 3)

Set this switch to ON for use.

Control Operation for Loop 1 (Pin 4)

Pin 4 selects forward (cooling) operation (ON) or reverse (heating) operation (OFF) for control loop 1.

Control Operation for Loop 2 (Pin 5)

Pin 5 selects forward (cooling) operation (ON) or reverse (heating) operation (OFF) for control loop 2.

Control Method (Pin 6)

Pin 6 selects either ON/OFF control (ON) or PID control (OFF).

- If ON/OFF control is being used, the width of the hysteresis loop (hysteresis) can be set to adjust the control sensitivity.
- If PID control (PID control with two degrees of freedom) is being used, the PID constants can be set automatically with the autotuning function.

Initialize Non-volatile Memory Set Values (Pin 7)

If pin 7 is ON, the setting data in non-volatile memory will be initialized to their default settings when the Temperature Control Unit restarts or the Controller is reset, including when the power is turned ON. (Initialize non-volatile memory only when a Hardware Check Error has occurred. Refer to *ERC Indicator Lit and RUN Indicator Not Lit* in 5-1 Error and Alarm Processing for details.)

Transfer Set Values in Non-volatile Memory (Pin 8)

If pin 8 is ON, the setting data in the Temperature Control Unit's non-volatile memory will be transferred to the corresponding device variable for CJ-series Unit of the CPU Unit when the Temperature Control Unit restarts or the Controller is reset, including when the power is turned ON. Turn ON pin 8 if you want the Temperature Control Unit to operate with setting data stored in non-volatile memory.

The set values in the Temperature Control Unit's RAM can be saved to non-volatile memory by turning ON the corresponding Save Settings Bits (**_Ch1_SaveCmd* and **_Ch2_SaveCmd*) of the device variables for CJ-series Unit. Refer to 2-5-3 Saving Set Value in the Non-volatile Memory for details on the settings.

2-3-5 Input Type Switch

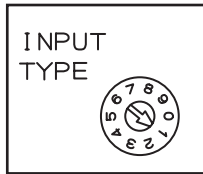

● Thermocouple Temperature Control Units

Input type setting	Type	Temperature ranges	
		Centigrade	Fahrenheit
0	K	-200 to 1,300°C	-300 to 2,300°F
1	K	0.0 to 500.0°C	0.0 to 900.0°F
2	J	-100 to 850°C	-100 to 1,500°F
3	J	0.0 to 400.0°C	0.0 to 750.0°F
4	T	-200.0 to 400.0°C	-300.0 to 700.0°F
5	L	-100 to 850°C	-100 to 1,500°F
6	L	0.0 to 400.0 °C	0.0 to 750.0°F
7	R	0 to 1,700°C	0 to 3,000°F
8	S	0 to 1,700°C	0 to 3,000°F
9	B	100 to 1,800°C	300 to 3,200°F

● Platinum Resistance Thermometer Temperature Control Units

Input type setting	Type	Temperature ranges	
		Centigrade	Fahrenheit
0	Pt100	-200.0 to 650.0°C	-300.0 to 1,200.0°F
1	JPt100	-200.0 to 650.0°C	-300.0 to 1,200.0°F
2 to 9	Do not set 2 through 9.		

2-4 Wiring

2-4-1 Terminal Wiring Examples

● Thermocouple Temperature Control Units

CJ1W-TC003 (2 loops, NPN outputs, HB alarm)			CJ1W-TC004 (2 loops, PNP outputs, HB alarm)		
Input 2 -	B1	A1 Input 1 -	Input 2 -	B1	A1 Input 1 -
Input 2 +	B2	A2 Input 1 +	Input 2 +	B2	A2 Input 1 +
Cold-junction comp.	B3	A3 N.C.	Cold-junction comp.	B3	A3 N.C.
Cold-junction comp.	B4	A4 N.C.	Cold-junction comp.	B4	A4 N.C.
CT input 2	B5	A5 CT input 1	CT input 2	B5	A5 CT input 1
CT input 2	B6	A6 CT input 1	CT input 2	B6	A6 CT input 1
Output 2	B7	A7 Output 1	Output 2	B7	A7 Output 1
HB output 2	B8	A8 HB output 1	HB output 2	B8	A8 HB output 1
0 V COM (-)	B9	A9 24 V	0 V	B9	A9 24 V COM (+)

● Platinum Resistance Thermometer Temperature Control Units

CJ1W-TC103 (2 loops, NPN outputs, HB alarm)			CJ1W-TC104 (2 loops, PNP outputs, HB alarm)		
Input 2 B'	B1	A1 Input 1 B'	Input 2 B'	B1	A1 Input 1 B'
Input 2 B	B2	A2 Input 1 B	Input 2 B	B2	A2 Input 1 B
Input 2 A	B3	A3 Input 1 A	Input 2 A	B3	A3 Input 1 A
N.C.	B4	A4 N.C.	N.C.	B4	A4 N.C.
CT input 2	B5	A5 CT input 1	CT input 2	B5	A5 CT input 1
CT input 2	B6	A6 CT input 1	CT input 2	B6	A6 CT input 1
Output 2	B7	A7 Output 1	Output 2	B7	A7 Output 1
HB output 2	B8	A8 HB output 1	HB output 2	B8	A8 HB output 1
0 V COM (-)	B9	A9 24 V	0 V	B9	A9 24 V COM (+)

When not using temperature input terminals:

- For a resistance thermometer, connect a resistance of approximately 100 to 200 Ω between terminals A and B, and establish a short between terminals B and B'.
- Short the input terminals for thermocouples.
- Do not connect anything to terminals that are not being used.



Precautions for Correct Use

Do not connect any wiring to the N.C. terminals.

2-4-2 Output Circuits

The following diagrams show the internal output circuits.

Output Circuits

- NPN Outputs (CJ1W-□03)

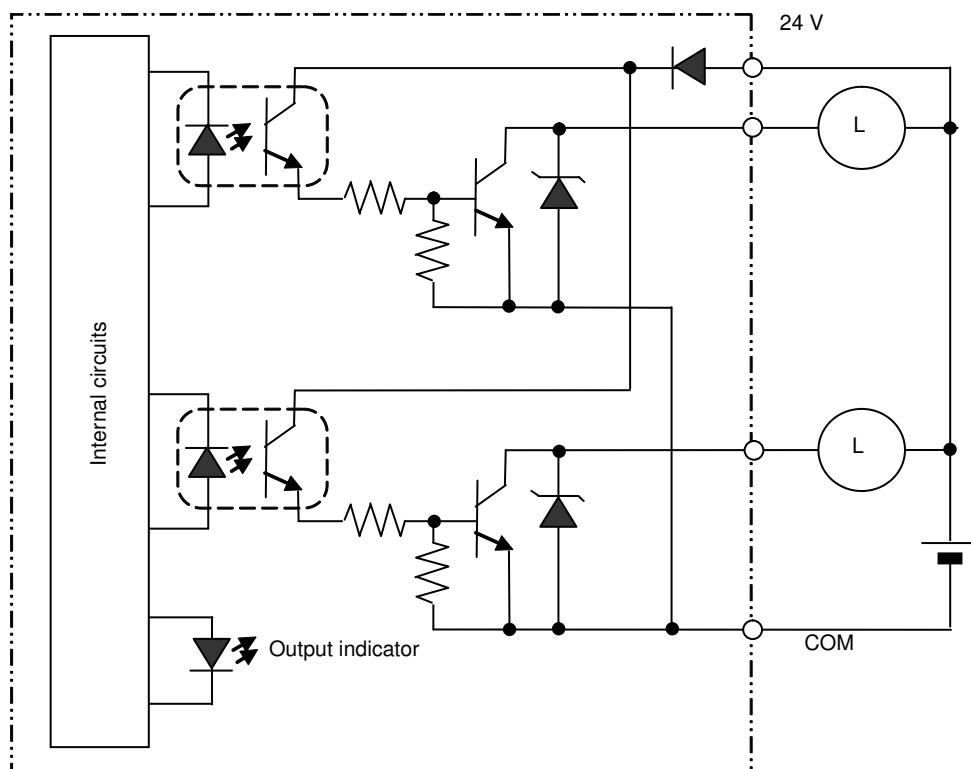

● PNP Outputs (CJ1W-□04)

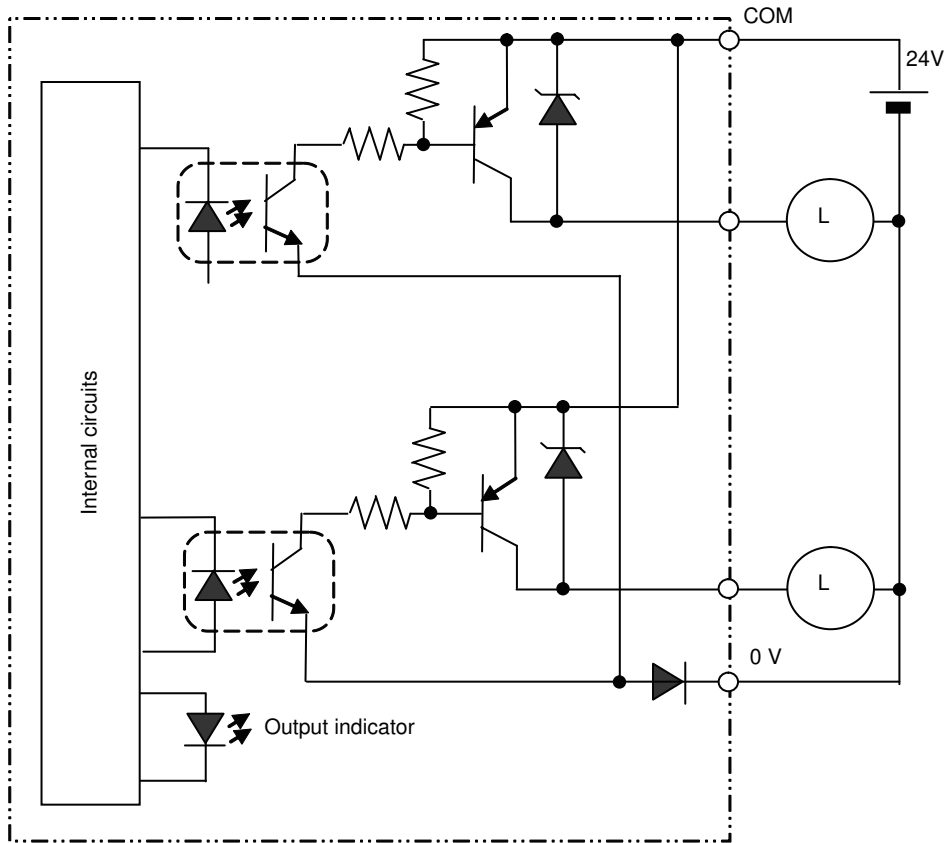

2-4-3 I/O Wiring Examples

● Thermocouple Temperature Control Units

CJ1W-TC003
(2 loops, HB alarm, NPN outputs)

CJ1W-TC004
(2 loops, HB alarm, PNP outputs)

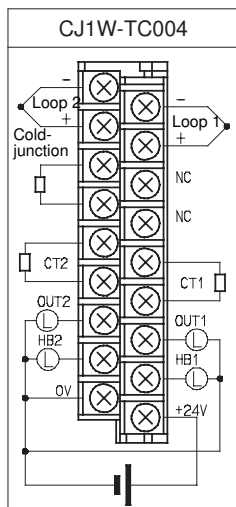
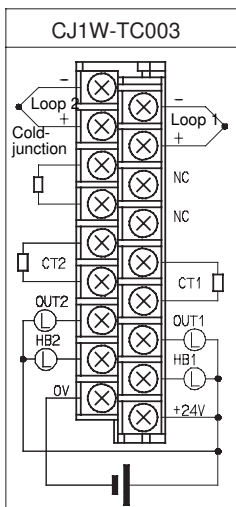

- Do not touch or remove the cold junction sensor.
- Use the type of sensor selected on the Input Type Switch.
- The Temperature Control Unit and Terminal Block are a matched set, so use the Temperature Control Unit and Terminal Block with matching serial numbers.

- Do not connect anything to the N.C. terminals. (The N.C. terminals cannot even be used as junction terminals.)
- Do not connect any Current Transformer to the CT input terminals other than an OMRON E54-CT1 or E54-CT3.

● Platinum Resistance Thermometer Temperature Control Units

CJ1W-TC103

(2 loops, HB alarm, NPN outputs)

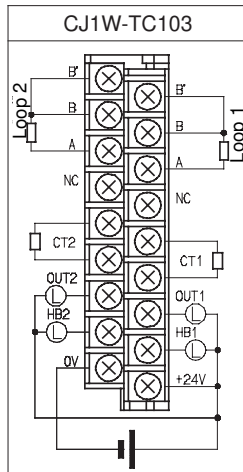

CJ1W-TC104

(2 loops, HB alarm, PNP outputs)

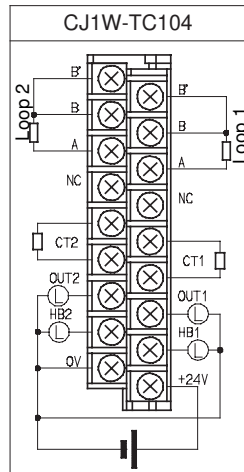

- Use the type of sensor selected on the Input Type Switch.
- Do not connect anything to the N.C. terminals. (The N.C. terminals cannot even be used as junction terminals.)
- Do not connect any Current Transformer to the CT input terminals other than an OMRON E54-CT1 or E54-CT3.
- Always attach crimp terminals to the wiring that connects to the terminal block and tighten the terminal screws securely. The terminal screws are M3 screws and need to be tightened to a torque of 0.5 N·m.
- Use wire that is AWG 22 to AWG 18 (0.32 to 0.82mm²).

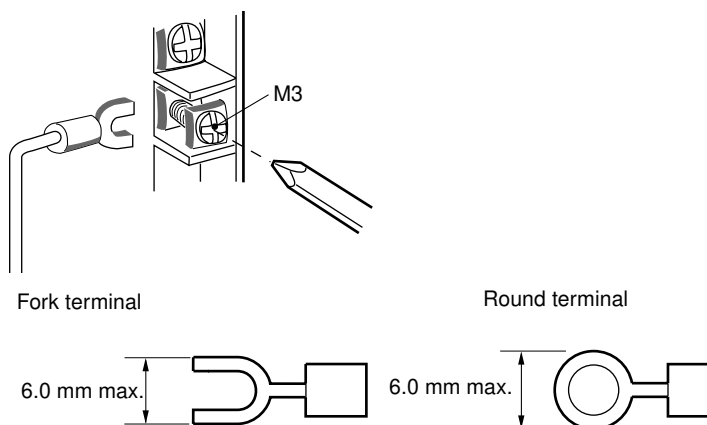

Observe the following precautions when wiring to minimize noise and optimize the Temperature Control Unit's operation.

- Use twisted-pair shielded wire for the output wiring.
- Keep the I/O lines away from power lines including AC power supply lines and high-power lines. Do not run the I/O lines in the same duct or conduit as power lines.

- Noise from the power supply line may be superimposed on I/O signals if equipment that generates high frequency noise is used nearby or the Temperature Control Unit's power line is shared with electrical welding equipment or discharging equipment. In this case, install a noise filter at the power supply inputs.

2-5 Data Exchange with the CPU Unit

2-5-1 Overview

The Temperature Control Unit exchanges data with the CPU Unit through the I/O port generated for the Temperature Control Unit.

- Operation Data
- Initialization Data
- Operating Parameters

The table and diagram show the data exchange method for each data type.

Data exchange type

Unit data type	Data contents	AT specification destination	How to access from user program	Timing of data exchange
Operation Data	Process value, set point, start AT bit, stop AT bit, etc.	I/O port (Operation Data)	Device variable for CJ-series Unit	I/O refresh period
Initialization Data	Alarm mode, alarm hysteresis, etc.	I/O port (Initialization Data) (*)		When the Controller is reset or the Unit restarts
Operating Parameter	Alarm SVs, control period, proportional band, integral time, etc.	I/O port (Operating Parameters) (*)		I/O refresh period
Unit Restart Flag, etc.	Unit Restart Flag, etc.	None	System-defined variable	

* The Initialization Data and Operating Parameters are retained in the CPU Unit by the battery even during power interruptions.

NJ-series CPU Unit

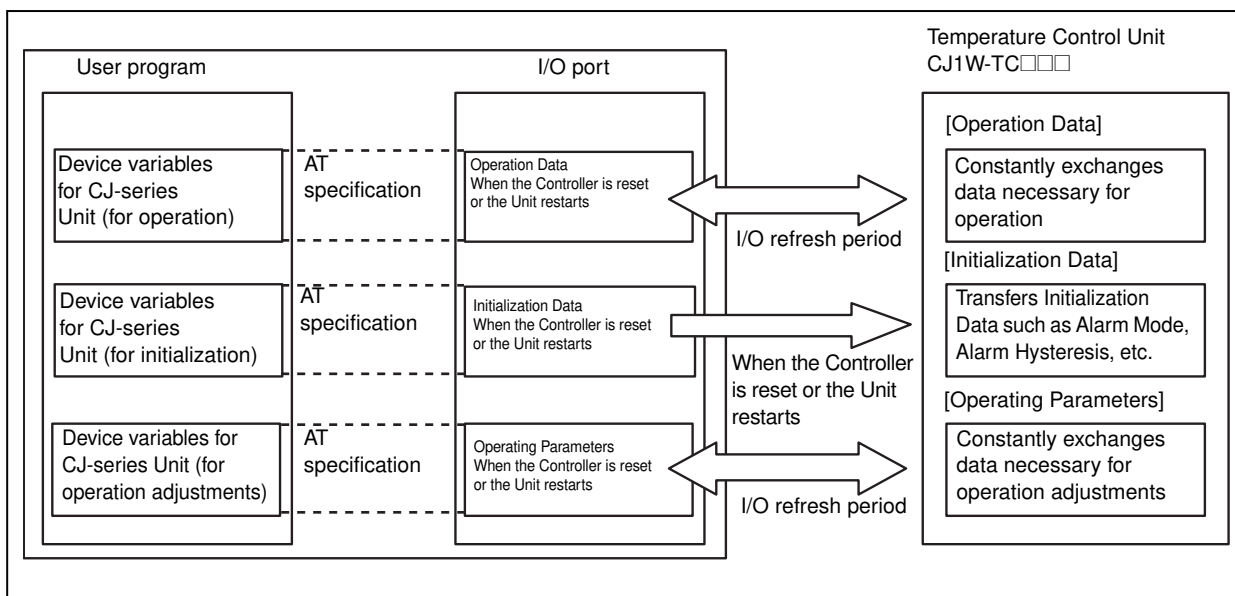

Device Variables for CJ-series Unit

These are variables used to exchange data between the user program and Special I/O Unit.

Three types of device variables for CJ-series Unit are available: "Operation Data", "Initialization Data" and "Operating Parameters".

For details, refer to 2-5-2 Accessing from the User Program.

Unit Restart

To resume operation after changing settings in the Initialization Data or removing the cause of errors, first restart the Unit with one of the methods described below.

Initialization Data are updated after restart.

- Reset the Controller from Sysmac Studio.
- Reset the Controller from cycling the power supply to the controller
- Restart using the ResetUnit instruction of the program
- Restart using a system-defined variable.

Variable name	Type	
<code>_CJB_SIO**Restart</code>	BOOL	Unit number 00 to 94 in **



Precautions for Correct Use

- If the error persists after the restart, replace this Unit.
- During restart, output is 0 V as the data immediately before restart is maintained for input.

2-5-2 Accessing from the User Program

The user program controls the Temperature Control Unit using the device variables for CJ-series Unit. Allocate variables for CJ-series Units to the I/O port, which is explained below.

● I/O port

An "I/O port" is a logical interface to enable the CPU Unit to exchange data with configuration units such as the Temperature Control Unit.

An I/O port has a unique predefined name for each unit model and function.

An I/O port is automatically created by preparing the Unit Configuration with Sysmac Studio.

● How to Specify Device Variables for CJ-series Unit

Allocate variables for CJ-series Units to an I/O port with *I/O map* in the Sysmac Studio.

Specify the variable name for the AT specification with the following method.

- 1** Select a variable already registered in the variable table
- 2** Input a new variable name
- 3** Automatically create a variable name with "Device variable creation"

When a device variable name for CJ-series Unit is assigned with the method in 2 or 3, the variable input by Sysmac Studio is automatically registered in the variable table.

The following is the configuration of variable names created with 3. Automatic creation.

Name of device variable for CJ-series Unit

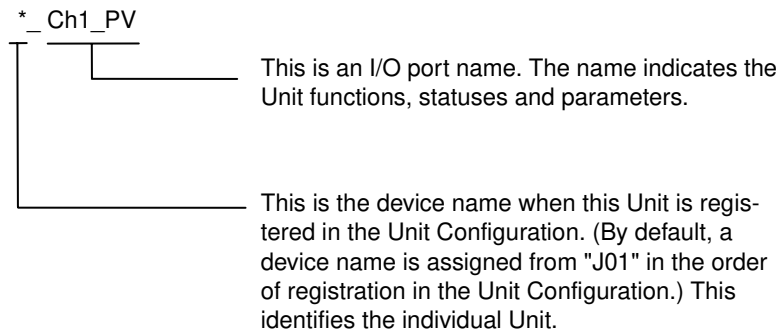

For details on creation of device variables for CJ-series Unit, refer to the *Sysmac Studio Version 1 Operation Manual* (Cat. No. W504).

There are 3 types of device variables for CJ-series Unit: "Operation Data", "Initialization Data" and "Operating Parameters".

In the explanations from here on, the device name automatically created is used as the device variables for CJ-series Unit, for example *_Ch1_PV.

2-5-3 Saving Set Value in the Non-volatile Memory

Caution

Do not turn OFF the power supply while setting data is being written to the non-volatile memory in the Temperature Control Unit.

Confirm that the Save Completed Flag turns ON after the data write operation has been completed before turning OFF the power supply. If power is turned OFF during a write operation, the data saved in the non-volatile memory may be destroyed.



The Temperature Control Unit has two types of memory: RAM and Non-volatile Memory.

Device variables for CJ-series Unit are written to the RAM in the Temperature Control Unit. For Operating Parameters among the device variables for CJ-series Unit, some of this data can be written from the RAM to non-volatile memory by turning ON the Save Settings Bits (*_Ch1_SaveCmd and *_Ch2_SaveCmd).

If pin 8 of the DIP switch is ON, the setting data stored in the non-volatile memory will automatically be transferred to the device variables for CJ-series Unit (Operating Parameters) when the Unit restarts or the Temperature Control Unit is reset, including when the power is turned ON.

Area allocated in CPU Unit		Set value	Transfer timing from device variables for CJ-series Unit in CPU Unit to RAM	Transfer timing from RAM to non-volatile memory	Transfer timing from non-volatile memory to device variables for CJ-series Unit in CPU Unit
Device variable for CJ-series Unit	Operation Data	Set point Heater Burnout Current	I/O refresh period	---	---
	Initialization Data	Alarm Mode Alarm Hysteresis	When the controller is reset or the Unit restart	---	---
	Operating Parameters	Alarm SVs Input Compensation Value Control Period Control Sensitivity	I/O refresh period	During I/O refreshing and PID Constants Calculated Flag is 0 *1	Setting data in RAM is written to non-volatile memory when you change the Save Settings Bits of the device variables for CJ-series Unit (for operation) from 0 to 1.*2
Proportional Band Integral Time Derivative Time					

*1 The PID constants resulting from autotuning are automatically written to RAM at the end of autotuning.

*2 Non-volatile memory can be written up to 100,000 times.

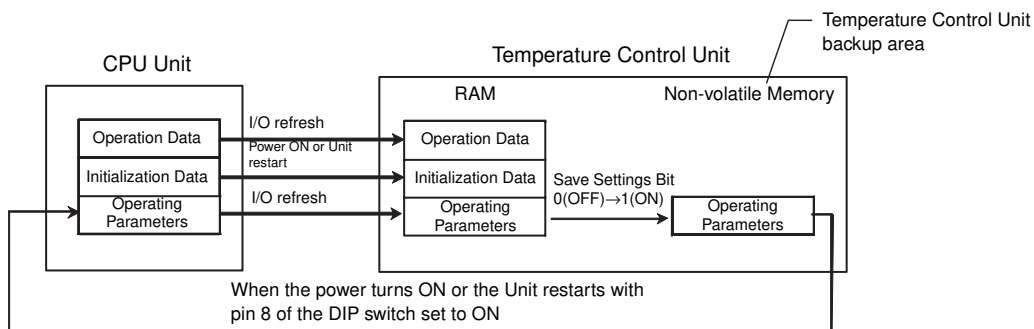

2-5-4 Operation Data

The Operation Data includes the Process Value, Set Points, Stop Bits, Start AT Bits, Stop AT Bits, and other basic data.

Operation data is exchanged each cycle time during the I/O refresh period.

Input data is transferred from the Temperature Control Unit to the CPU Unit and output data is transferred from the CPU Unit to the Temperature Control Unit.

Allocating Operation Data to Device Variables for CJ-series Unit

Device variables for CJ-series Unit are shown below.

For the setting range and monitoring range of each value, refer to 2-6 *Range of Set Values and Monitor Values*.

The meaning of the row of "R/W" in the table below is as follows:

RW: Read/Write

R: Read only

Device variable for CJ-series Unit		Data type	R/W	Name	Function
Loop 1	Loop 2				
*_Ch1_PV	*_Ch2_PV	INT	R	Loop 1 and Loop 2 Process Value	If the process value exceeds the allowed indication range, a sensor error will occur, "*_Ch#_SensErr" (Sensor Error Flag) will become 1, and the PV will contain the data "-13,108".
*_Ch1_HtrCurVal	*_Ch2_HtrCurVal	UINT	R	Loop 1 and Loop 2 Heater Current	If the measured heater current exceeds 55.0 A, "*_Ch#_CTOVflg" (CT Overflow Flag) will become 1 and the heater current will be stored as "-13,108".
*_Ch1_SetPointCfg	*_Ch2_SetPointCfg	INT	RW	Loop 1 and Loop 2 Set point	Set the set point of loop 1 and loop 2.
*_Ch1_SetPointSta	*_Ch2_SetPointSta	INT	R	Loop 1 and Loop 2 Set point for Monitor	Indicate the current set point of loop 1 and loop 2.
*_Ch1_HBLvlCfg	*_Ch2_HBLvlCfg	UINT	RW	Loop 1 and Loop 2 Heater Burnout Current	Set the heater burnout current of loop 1 and loop 2. If the set value is set to 0.0, heater burnouts will not be detected. If the set value is set to 50.0, the heater burnout output will always be ON. (This can be used to check wiring.)
*_Ch1_HBLvlSta	*_Ch2_HBLvlSta	UINT	R	Loop 1 and Loop 2 Heater Burnout Current for Monitor	Indicate the current set heater burnout current of loop 1 and loop 2.
*_Ch1_StartATCmd	*_Ch2_StartATCmd	BOOL	RW	Loop 1 and Loop 2 Start AT Bit	Turn ON the Start AT to start autotuning for loop 1 and loop 2. The status of the Stop AT is ignored if "*_Ch#_StopATCmd" (Stop AT Bit) is set to 1.

Device variable for CJ-series Unit		Data type	R/W	Name	Function
Loop 1	Loop 2				
*_Ch1_StopATCmd	*_Ch2_StopATCmd	BOOL	RW	Loop 1 and Loop 2 Stop AT Bit	Turn ON the Stop AT to stop autotuning for loop 1 and loop 2. The status of the Stop AT is ignored if autotuning is not being performed.
*_Ch1_StopCtlCmd	*_Ch2_StopCtlCmd	BOOL	RW	Loop 1 and Loop 2 Stop Bit	Set the Stop Bit to 0 to perform temperature control for loop 1 and loop 2 and set it to 1 to stop temperature control for loop 1 and loop 2. The Stop Bit will not function if pin 1 of the DIP switch is OFF and the CPU Unit is in PROGRAM mode.
*_Ch1_ChgPIDCmd	*_Ch2_ChgPIDCmd	BOOL	RW	Loop 1 and Loop 2 change PID Constants Bit	When a Change PID Constants Bit is set from 0 to 1, the corresponding " <i>*_Ch#_PIDCalcFlg</i> " (PID Constants Calculated Flag) will be set from 1 to 0 and the PID constants stored as Operating Parameters will be retransferred to RAM in the Temperature Control Unit.
*_Ch1_SaveCmd	*_Ch2_SaveCmd	BOOL	RW	Loop 1 and Loop 2 Save Settings Bit	The set values of the applicable loop are written from RAM to non-volatile memory in the Temperature Control Units when a Save Settings Bit is set from 0 to 1. DO NOT turn OFF the power supply when data is being written from RAM to non-volatile memory. Confirm that " <i>*_Ch#_SaveFlg</i> " (Save Completed Flag) is set to 1 (data is written to memory) before turning OFF the power supply.

Device variable for CJ-series Unit		Data type	R/W	Name	Function
Loop 1	Loop 2				
*_Ch1_StaWd	*_Ch2_StaWd	WORD	R	Loop 1 and Loop 2 Status	<p>Bits serve the functions described below.</p> <p>Each bit is defined with a BOOL data type variable.</p> <p>Bit 00: Loop 1 and Loop 2 AL1 Flag</p> <p>Bit 01: Loop 1 and Loop 2 AL1 Flag</p> <p>Bit 02: Loop 1 and Loop 2 HB Flag</p> <p>Bit 03: Loop 1 and Loop 2 AT Flag</p> <p>Bit 04: Loop 1 and Loop 2 Control Output Flag</p> <p>Bit 05:</p> <p>Bit 06:</p> <p>Bit 07:</p> <p>Bit 08: Loop 1 and Loop 2 Stop Flag</p> <p>Bit 09: Loop 1 and Loop 2 Setting Error Flag</p> <p>Bit 10: Loop 1 and Loop 2 PID Constants Calculated Flag</p> <p>Bit 11: Loop 1 and Loop 2 Standby Flag</p> <p>Bit 12: Loop 1 and Loop 2 Cold Junction Sensor Error</p> <p>Bit 13: Loop 1 and Loop 2 CT Overflow Flag</p> <p>Bit 14: Loop 1 and Loop 2 Sensor Error Flag</p> <p>Bit 15: Loop 1 and Loop 2 Save Completed Flag</p>
*_Ch1_AL1Flg	*_Ch2_AL1Flg	BOOL	R	Loop 1 and Loop 2 AL1 Flag	<p>The value becomes 1 when the temperature is within the alarm range set for the input value of loop 1 and loop 2. The value becomes 0 when the temperature is not within the alarm range set for the input value.</p>
*_Ch1_AL2Flg	*_Ch2_AL2Flg	BOOL	R	Loop 1 and Loop 2 AL2 Flag	<p>The value becomes 1 when the temperature is within the alarm range set for the input value of loop 1 and loop 2. The value becomes 0 when the temperature is not within the alarm range set for the input value.</p>
*_Ch1_HBFlg	*_Ch2_HBFlg	BOOL	R	Loop 1 and Loop 2 HB Flag	<p>The value becomes 1 if the detected heater current does not exceeds the Heater Burn-out Current.</p>

Device variable for CJ-series Unit		Data type	R/W	Name	Function
Loop 1	Loop 2				
*_Ch1_ATFlg	*_Ch2_ATFlg	BOOL	R	Loop 1 and Loop 2 AT Flag	The value becomes 1 during autotuning of loop 1 and loop 2. The value becomes 0 when autotuning stops or finishes.
*_Ch1_CtlOutFlg	*_Ch2_CtlOutFlg	BOOL	R	Loop 1 and Loop 2 Control Output Flag	The value becomes 1 when the control output of loop 1 and loop 2 is ON.
*_Ch1_StopFlg	*_Ch2_StopFlg	BOOL	R	Loop 1 and Loop 2 Stop Flag	The value becomes 0 when the Temperature Control Unit is controlling the temperature of loop 1 and loop 2. The value becomes 1 when the Temperature Control Unit is not controlling the temperature of loop 1 and loop 2.
*_Ch1_SetErr	*_Ch2_SetErr	BOOL	R	Loop 1 and Loop 2 Setting Error Flag	The value becomes 1 when there is an error in the set values in the device variable for CJ-series Unit.
*_Ch1_PIDCalcFlg	*_Ch2_PIDCalcFlg	BOOL	R	Loop 1 and Loop 2 PID Constants Calculated Flag	The value becomes 1 when the PID constants calculated by the Temperature Control Unit for autotuning are updated. When this value is 1, the PID constants in the Operating Parameters are not output to the Temperature Control Unit. When this value is 0, the PID constants in the Operating Parameters are output to the Temperature Control Unit.
*_Ch1_StbyFlg	*_Ch2_StbyFlg	BOOL	R	Loop 1 and Loop 2 Standby Flag	The value becomes 1 when the Temperature Control Unit is waiting for I/O refreshing after the Controller is reset or the Unit is restarted.
*_Ch1_CJErr	*_Ch2_CJErr	BOOL	R	Loop 1 and Loop 2 Cold Junction Sensor Error	The value becomes 1 for the following: • Cold junction sensor error
*_Ch1_CTOvfFlg	*_Ch2_CTOvfFlg	BOOL	R	Loop 1 and Loop 2 CT Overflow Flag	The value becomes 1 if the heater current detected by the CT (Current Transformer) exceeds 55.0 A.

Device variable for CJ-series Unit		Data type	R/W	Name	Function
Loop 1	Loop 2				
*_Ch1_SensErr	*_Ch2_SensErr	BOOL	R	Loop 1 and Loop 2 Sensor Error Flag	The value becomes 1 for the following: <ul style="list-style-type: none"> • A sensor is not connected to loop 1. • The connection to sensor of loop 1 is broken. • A temperature exceeding the measurable input range is input.
*_Ch1_SaveFlg	*_Ch2_SaveFlg	BOOL	R	Loop 1 and Loop 2 Save Completed Flag	The value becomes 1 when writing data to non-volatile memory is completed after setting "_Ch#_SaveCmd" (Save Settings Bit) of loop 1 and loop 2 from 0 to 1. The Save Completed Flag initializes to 0 when "_Ch#_SaveCmd" (Save Settings Bit) of loop 1 and loop 2 is set from 1 to 0. (It is 0 immediately after the controller is reset.)
*_DecPointSetErrSta		WORD	R	Loop 1, 2 Decimal Point and Loop 1, 2 Setting Error Number	Specify the decimal point position of the PV/SP for loop 1 and loop 2. The number of loop 1 and loop 2 settings in which a setting error exists is stored in hexadecimal.

● Explanation of Decimal Point and Setting Error Numbers

	Bit															
	15	14	13	12	11	10	09	08	07	06	05	04	03	02	01	00
*_DecPointSetErrSta	Decimal Point								Setting Error Numbers							
	Loop 1 (0/1)				Loop 2 (0/1)				Loop 1 (0 to F)				Loop 2 (0 to F)			

● Setting Error Numbers

Setting error number	Setting name	Priority
1	Alarm Mode 1	1
2	Alarm Mode 2	2
3	Alarm 1 Hysteresis	3
4	Alarm 2 Hysteresis	4
5	Set Point	5
6	Alarm 1 SV	6
7	Alarm 2 SV	7
8	Input Compensation Value	8
9	Control Period	9
A	Control Sensitivity	10
B	Proportional Band	11
C	Integral Time	12

Setting error number	Setting name	Priority
D	Derivative Time	13
E	Heater Burnout Current	14
F	No allocation	15

In the case there are multiple setting errors, the setting error number with the highest priority is stored.

2-5-5 Initialization Data

The Temperature Control Unit is initialized.

If you are using the temperature alarm function, the alarm mode setting and alarm hysteresis setting must be written to the appropriate device variables for CJ-series Unit.

Initialization Data settings are set from the I/O Port screen in Configurations and Setup of Sysmac Studio. The data setup file will be reflected in the I/O port (Initialization Data).

Reset the Controller or restart the Unit after setting is complete. The settings in the Initialization Data are reflected in the unit when the Controller is reset or when the unit restarts.

The Initialization Data is retained in the CPU Unit by the battery even during power interruptions.



Precautions for Safe Use

When you change the unit settings and reset the Controller or restart the unit, be sure to first properly check the safety of the devices at the connection destination.

Allocating Initialization Data to Device Variables for CJ-series Unit

Device variables for CJ-series Unit (for initialization) that can be allocated with Initialization Data are shown below.

For the setting range and monitoring range of each value, refer to *2-6 Range of Set Values and Monitor Values*.

The meaning of the row of "R/W" in the table below is as follows:

RW: Read/Write

R: Read only

Device variable for CJ-series Unit		Data type	R/W	Name	Function
Loop 1	Loop 2				
*_Ch1_AL1HysC fg	*_Ch2_AL1HysC fg	UINT	RW	Loop 1 and Loop 2 Alarm 1 Hysteresis	Set the Alarm 1 hysteresis.
*_Ch1_AL2HysC fg	*_Ch2_AL2HysC fg	UINT	RW	Loop 1 and Loop 2 Alarm 1 Hysteresis	Set the Alarm 2 hysteresis.
*_AlmMd		WORD	RW	Loop 1, 2 Alarm 1 Mode and Alarm 2 Mode	Alarm 1 Mode and Alarm 2 Mode of Loop 1 and Loop 2 16#0: No alarm 16#1: Upper and lower- limit alarm 16#2: Upper-limit alarm 16#3: Lower-limit alarm 16#4: Upper and lower- limit range alarm 16#5: Upper and lower- limit alarm with standby sequence 16#6: Upper-limit alarm with standby sequence 16#7: Lower-limit alarm with standby sequence 16#8: Absolute-value upper limit alarm 16#9: Absolute-value lower limit alarm The values written are written to RAM.

● Explanation of Alarm Modes

	Bits															
	15	14	13	12	11	10	09	08	07	06	05	04	03	02	01	00
*_AlmMd	Loop 1								Loop 2							
	Alarm 1 Mode				Alarm 2 Mode				Alarm 1 Mode				Alarm 2 Mode			
	2 ³	2 ²	2 ¹	2 ⁰	2 ³	2 ²	2 ¹	2 ⁰	2 ³	2 ²	2 ¹	2 ⁰	2 ³	2 ²	2 ¹	2 ⁰

Note Setting Alarm 1 or Alarm 2 Mode to "16#FF" will disable the corresponding loop. Control operations will stop and ERC indicator will not light by alarms.
Example: To disable loop 2, set *AlmMd* (Loop 1, 2 Alarm 1 Mode and Alarm 2 Mode) to "16#00FF".

2-5-6 Operating Parameters

The Temperature Control Unit's Operating Parameters exchange the Temperature Control Units Alarm SVs, control periods, and other Operating Parameters with the CPU Unit.

Operating Parameters are exchanged each cycle during the I/O refresh period. Input data is transferred from the Temperature Control Unit to the CPU Unit and output data is transferred from the CPU Unit to the Temperature Control Unit.

The Operating Parameters are retained in the CPU Unit by the battery even during power interruptions.

Allocating Operating Parameters to Device Variables for CJ-series Unit

Device variables for CJ-series Unit (Operation Parameters) that can be allocated with Operating Parameters are shown below.

For the setting range and monitoring range of each value, refer to *2-6 Range of Set Values and Monitor Values*.

The meaning of the row of "R/W" in the table below is as follows:

RW: Read/Write

R: Read only

Device variable for CJ-series Unit		Data type	R/W	Name	Function
Loop 1	Loop 2				
*_Ch1_MV	*_Ch2_MV	INT	R	Loop 1 and Loop 2 Manipulated Variable Monitor	When ON/OFF control is used, this value will be 100% for ON and 0% for OFF.
*_Ch1_AL1LvlCfg	*_Ch2_AL1LvlCfg	INT	RW	Loop 1 and Loop 2 Alarm 1 SV	Set the alarm 1 detection level.
*_Ch1_AL1LvlSta	*_Ch2_AL1LvlSta	INT	R	Loop 1 and Loop 2 Alarm 1 SV for Monitor	The Temperature Control Unit returns the set values that are actually used for temperature control. Use these values to monitor operation.
*_Ch1_AL2LvlCfg	*_Ch2_AL2LvlCfg	INT	RW	Loop 1 and Loop 2 Alarm 2 SV	Set the alarm 2 detection level.
*_Ch1_AL2LvlSta	*_Ch2_AL2LvlSta	INT	R	Loop 1 and Loop 2 Alarm 2 SV for Monitor	The Temperature Control Unit returns the set values that are actually used for temperature control. Use these values to monitor operation.
*_Ch1_AllnOfsCfg	*_Ch2_AllnOfsCfg	INT	RW	Loop 1 and Loop 2 Input Compensation Value	Set the input compensation value.

Device variable for CJ-series Unit		Data type	R/W	Name	Function
Loop 1	Loop 2				
*_Ch1_AllnOfsSta	*_Ch2_AllnOfsSta	INT	R	Loop 1 and Loop 2 Input Compensation Value for Monitor	The Temperature Control Unit returns the set values that are actually used for temperature control. Use these values to monitor operation.
*_Ch1_CtlPrdCfg	*_Ch2_CtlPrdCfg	UINT	RW	Loop 1 and Loop 2 Control Period	Set the control period.
*_Ch1_CtlPrdSta	*_Ch2_CtlPrdSta	UINT	R	Loop 1 and Loop 2 Control Period for Monitor	The Temperature Control Unit returns the set values that are actually used for temperature control. Use these values to monitor operation.
*_Ch1_CtlHysTrsCfg	*_Ch2_CtlHysTrsCfg	UINT	RW	Loop 1 and Loop 2 Control Sensitivity	This setting is valid in ON/OFF control only.
*_Ch1_CtlHysTrsSta	*_Ch2_CtlHysTrsSta	UINT	R	Loop 1 and Loop 2 Control Sensitivity for Monitor	The Temperature Control Unit returns the set values that are actually used for temperature control. Use these values to monitor operation.
*_Ch1_ProportionalBandCfg	*_Ch2_ProportionalBandCfg	UINT	RW	Loop 1 and Loop 2 Proportional Band	The values written here are not written to RAM while "_Ch#_PIDCalcFlg" (PID Constants Calculated Flag) is set to 1. These settings are valid in PID control only.
*_Ch1_ProportionalBandSta	*_Ch2_ProportionalBandSta	UINT	R	Loop 1 and Loop 2 Proportional Band for Monitor	The Temperature Control Unit returns the set values that are actually used for temperature control. Use these values to monitor operation.
*_Ch1_IntgTmCfg	*_Ch2_IntgTmCfg	UINT	RW	Loop 1 and Loop 2 Integral Time	The values written here are not written to RAM while "_Ch#_PIDCalcFlg" (PID Constants Calculated Flag) is set to 1. These settings are valid in PID control only.

Device variable for CJ-series Unit		Data type	R/W	Name	Function
Loop 1	Loop 2				
*_Ch1_IntgTmSta	*_Ch2_IntgTmSta	UINT	R	Loop 1 and Loop 2 Integral Time for Monitor	The Temperature Control Unit returns the set values that are actually used for temperature control. Use these values to monitor operation.
*_Ch1_DerivativeTmCfg	*_Ch2_DerivativeTmCfg	UINT	RW	Loop 1 and Loop 2 Derivative Time	The values written here are not written to RAM while "_Ch#_PIDCalcFlg" (PID Constants Calculated Flag) is set to 1. These settings are valid in PID control only.
*_Ch1_DerivativeTmSta	*_Ch2_DerivativeTmSta	UINT	R	Loop 1 and Loop 2 Derivative Time for Monitor	The Temperature Control Unit returns the set values that are actually used for temperature control. Use these values to monitor operation.

2-6 Range of Set Values and Monitor Values

2-6-1 Set Values

Device variable for CJ-series Unit	Setting	Data range	Unit	Default value	Non-volatile memory save
*_Ch1_SetPointCfg *_Ch2_SetPointCfg	Set point	Depends on the Input Type setting. Refer to 2-1-3 <i>Input Specifications</i> for details.	°C or °F	0 or 0.0	N/A
*_Ch1_HBLvICfg *_Ch2_HBLvICfg	Heater Burnout Current*1	0 to 500 (0.0 to 50.0)	A	0.0	
*_AlmMd	Loop 1, 2 Alarm 1 Mode and Alarm 2 Mode	0 to 9999 0: No alarm 1: Upper and lower-limit alarm 2: Upper-limit alarm 3: Lower-limit alarm 4: Upper and lower-limit range alarm 5: Upper and lower-limit alarm with standby sequence 6: Upper-limit alarm with standby sequence 7: Lower-limit alarm with standby sequence 8: Absolute-value upper-limit alarm 9: Absolute-value lower-limit alarm	---	0	N/A
*_Ch1_AL1HystrsCfg *_Ch2_AL1HystrsCfg *_Ch1_AL2HystrsCfg *_Ch2_AL2HystrsCfg	Loop 1 and Loop 2 Alarm 1 and Alarm 2 Hysteresis	0 to 9999 (0.0 to 999.9)	°C or °F	0.0	

Device variable for CJ-series Unit	Setting	Data range	Unit	Default value	Non-volatile memory save
*_Ch1_AL1LvlCfg *_Ch2_AL1LvlCfg	Alarm 1 SV	-999 to 9999 (-999 to 9999)	°C or °F	0 or 0.0	<ul style="list-style-type: none"> The Temperature Control Unit's settings are written to RAM. When the Save Settings Bit of the device variables for CJ-series Unit (for operation) is turned to 1, the set values are written to non-volatile memory.*2 If DIP switch pin 8 is ON, the settings are automatically transferred from non-volatile memory to the CPU Unit when the Temperature Control Unit is restarted or the controller is reset, including when the power is turned ON.
*_Ch1_AL2LvlCfg *_Ch2_AL2LvlCfg	Alarm 2 SV	-999 to 9999 (-999 to 9999)	°C or °F	0 or 0.0	
*_Ch1_AllnOfsCfg *_Ch2_AllnOfsCfg	Input Compensation Value	-999 to 9999 (-999 to 9999)	°C or °F	0.0	
*_Ch1_CtlPrdCfg *_Ch2_CtlPrdCfg	Control Period	1 to 99 (1 to 99)	s	20	<ul style="list-style-type: none"> The Temperature Control Unit's settings are written to RAM. When the Save Settings Bit of the device variables for CJ-series Unit (for operation) is turned to 1, the set values are written to non-volatile memory. If DIP switch pin 8 is ON, the settings are automatically transferred from non-volatile memory to the CPU Unit when the Temperature Control Unit is restarted or the controller is reset, including when the power is turned ON.
*_Ch1_CtlHysrsCfg *_Ch2_CtlHysrsCfg	Control Sensitivity	0 to 9999 (0.0 to 999.9)	°C or °F	0.8	
*_Ch1_ProportionalBandCfg *_Ch2_ProportionalBandCfg	Proportional Band	0 to 9999 (0.0 to 999.9)	°C or °F	8.0	
*_Ch1_IntgTmCfg *_Ch2_IntgTmCfg	Integral Time	0 to 9999 (0 to 9999)	s	233	
*_Ch1_DerivativeTmCfg *_Ch2_DerivativeTmCfg	Derivative Time	0 to 9999 (0 to 9999)	s	40	

- *1 Heater burnout is not detected when you set the value to 0.0 A or 50.0 A.
When the value is 0.0: Heater Burnout Alarm OFF
When the value is 50.0: Heater Burnout Alarm ON
- *2 When Save Settings Bit of the operation data changes from 0 to 1, the set values of the corresponding loop are written in the non-volatile memory of the Temperature Control Unit.
Make sure that the number of times data is written to the non-volatile memory does not exceed 100,000 times.

Note When you set a value outside the setting range, the Setting Error Flag of the Operation Data turns ON and you are notified of the Setting Error Number. (In this case, the set value becomes invalid and the Unit operates using the previous set value.)

2-6-2 Monitor Values

Device variable for CJ-series Unit	Setting	Data range	Unit	Default value
*_Ch1_PV *_Ch2_PV	Process Value	Depends on the Input Type setting. Refer to 2-1-3 <i>Input Specifications</i> for details.	°C or °F	---
*_Ch1_HtrCurVal *_Ch2_HtrCurVal	Heater Current *1	0 to 550 (0.0 to 55.0)	A	---
*_Ch1_MV *_Ch2_MV	Manipulated Variable Monitor *2	0 to 1000 (0.0 to 100.0)	%	---

- *1 If the heater current exceeds 55.0 A, the monitor value will indicate "-13,108".
- *2 The Manipulated Variable Monitor indicates the manipulated variable that is presently being output.
When output is ON: 100.0%
When output is OFF: 0.0%

3

Settings Required for Temperature Control

This section explains the various settings required for temperature control.

3-1	Setting the Input Type	3-2
3-2	Selecting the Temperature Units	3-4
3-3	Setting the Pin 3 of the DIP Switch	3-5
3-4	Selecting the Control Operation (Forward/Reverse)	3-6
3-5	Selecting PID Control or ON/OFF Control	3-7
3-6	Setting the Control Period	3-8
3-7	Setting the Set Points	3-9
3-8	Using ON/OFF Control	3-10
3-9	Setting the PID Constants	3-11
3-10	Using the Alarm Output Function	3-15
3-11	Using the Heater Burnout Alarm	3-19
3-12	Starting and Stopping Temperature Control	3-21

3-1 Setting the Input Type

Set the input type of the temperature sensor being used. There are two types of Temperature Control Units available: One accepts thermocouple inputs and the other accepts platinum resistance thermometer inputs. Both types have an "INPUT TYPE" rotary switch on the front of the Unit to set the input type. Set the Input Type Switch to the correct setting for sensor and temperature range being used.

The input type setting applies to all of the Unit's control loops. It is not possible to set different input types for the different control loops.

Setting the Input Type Switch

Set the input type with the Input Type Switch on the front of the Unit. If this set value is changed, the new setting will not become effective until the Unit is restarted, or the controller is reset including when the power is turned ON.

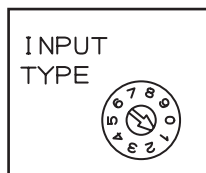

The diagram above shows the input type set for a K-type thermocouple with a temperature range of 0.0 to 500.0°C.

Input Type Settings

● Thermocouple Input Types

Sensor	Type	Input type setting	Temperature ranges	
			Centigrade	Fahrenheit
Thermocouple	K	0	-200 to 1,300°C	-300 to 2,300°F
		1	0.0 to 500.0°C	0.0 to 900.0°F
	J	2	-100 to 850°C	-100 to 1,500°F
		3	0.0 to 400.0°C	0.0 to 750.0°F
	T	4	-200.0 to 400.0°C	-300.0 to 700.0°F
	L	5	-100 to 850°C	-100 to 1,500°F
		6	0.0 to 400.0 °C	0.0 to 750.0°F
	R	7	0 to 1,700°C	0 to 3,000 °F
	S	8	0 to 1,700°C	0 to 3,000 °F
	B	9	100 to 1,800°C	300 to 3,200 °F

The factory setting is 0.

● Platinum Resistance Thermometer Input Types

Sensor	Type	Input type setting	Temperature ranges	
			Centigrade	Fahrenheit
Platinum resistance thermometer	Pt100	0	-200.0 to 650.0°C	-300.0 to 1,200.0°F
	JPt100	1	-200.0 to 650.0°C	-300.0 to 1,200.0°F
	----	2 to 9	Do not set 2 through 9.	

The factory setting is 0.

3-2 Selecting the Temperature Units

The Temperature Control Unit can operate in °C or °F. Select the desired temperature units with pin 2 of the DIP switch on the front of the Unit.

The temperature unit setting applies to all of the Unit's control loops. It is not possible to set different temperature unit settings for the different control loops.

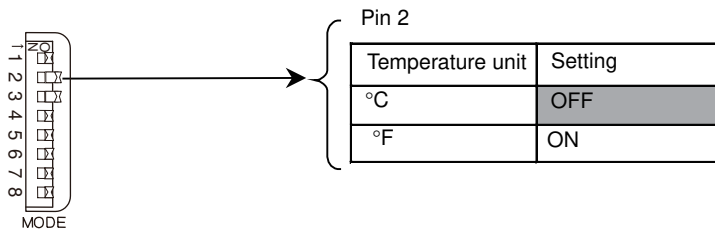

The factory setting is OFF (°C), as shown by the shading in the diagram above.

If this setting is changed, the new setting will not become effective until the Unit is restarted, or the controller is reset including when the power is turned ON.

3-3 Setting the Pin 3 of the DIP Switch

Set pin 3 (Data storage/display format) of the DIP switch to ON. (The factory setting is OFF.)

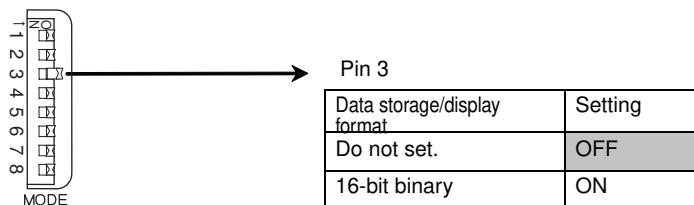

If this setting is changed, the new setting will not become effective until the Unit is restarted, or the controller is reset including when the power is turned ON.

3-4 Selecting the Control Operation (Forward/Reverse)

Forward (Cooling)/Reverse (Heating)

With forward operation (cooling), the manipulated variable is increased as the PV increases. With reverse operation (heating), the manipulated variable is increased as the PV decreases.

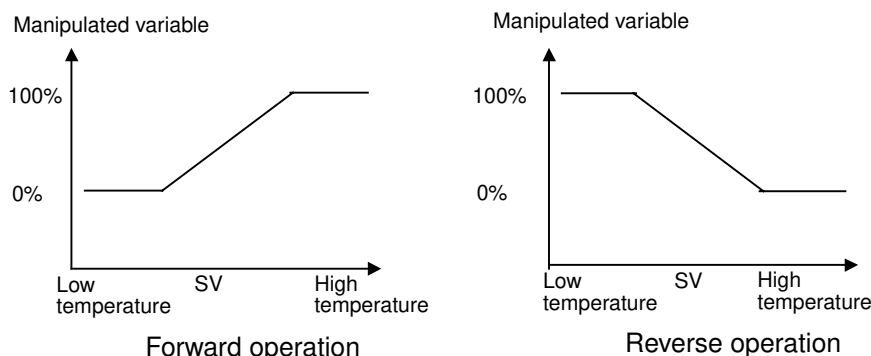

For example, when heating control is being performed and the process value (PV) is lower than the set point (SP), the manipulated variable is increased proportionally as the difference between the PV and SP increases. Consequently, heating control uses "reverse operation" and cooling control uses "forward operation." The factory setting is reverse operation (heating).

Set reverse operation or forward operation with loops 1 and 2.

Setting the Control Operation (Pins 4 and 5)

● Setting Loop 1 to Reverse Operation and Loop 2 to Forward Operation

If pin 4 is turned OFF and pin 5 is turned ON, loop 1 will be set for reverse operation (heating) and loop 2 will be set for forward operation (cooling).

The following diagram shows pins 4 and 5 set to their factory settings (OFF), which sets reverse operation (heating) for all loops.

If this setting is changed, the new setting will not become effective until the Unit is restarted, or the controller is reset including when the power is turned ON.

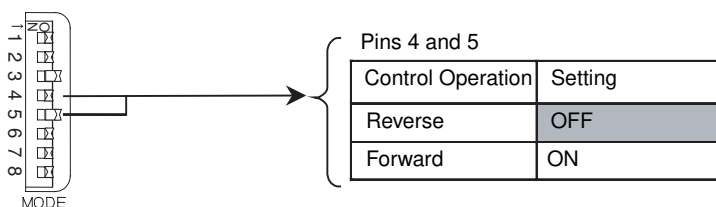

The factory setting is OFF.

3-5 Selecting PID Control or ON/OFF Control

A switch on the front of the Unit (pin 6 of the DIP switch) selects whether the Temperature Control Unit uses ON/OFF control or PID control with 2 degrees of freedom.

The control method setting applies to all of the Unit's control loops. It is not possible to set different control method settings for the different control loops.

If the control method setting is changed during operation, the new setting will not become effective until the power is turned OFF and ON again.

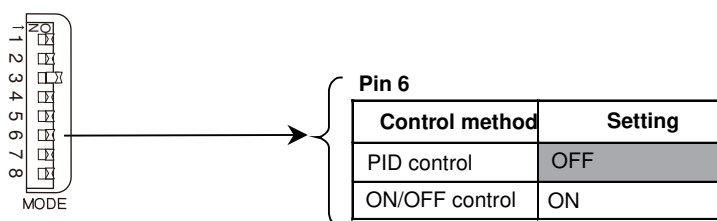

The factory setting is OFF (PID control), as shown in the diagram above.

If this setting is changed, the new setting will not become effective until the Unit is restarted or the controller is reset, including when the power is turned ON.

Setting the Control Method (Pin 6)

● PID Control with Two Degrees of Freedom

With PID control, it is necessary to set the proportional band (P), integral time (I), and derivative time (D). These settings can be made automatically with autotuning or manually. Refer to *3-9 Setting the PID Constants* for more details on the PID constants.

● ON/OFF Control

With ON/OFF control, the control output will be ON when the PV is below the SV. The control output will be OFF when the PV is at or above the SV. (This is the operation when the Unit is set for reverse operation. This operation will work in the opposite way for forward operation.)

3-6 Setting the Control Period

- This setting determines the output period (control period) for PID control. System control will improve with a shorter control period, but if you are using relays for heater control, we recommend setting a control period of at least 20 s to increase the relay's lifetime. If necessary, the control period can be adjusted during trial operation.
- Set the control period in the device variables for CJ-series Unit Loop 1 and Loop 2 Control Period (*_Ch1_CtlPrdCfg, *_Ch2_CtlPrdCfg). (See the following table.) The standard setting is 2 s, but the factory setting is 20 s.
- Each control loop has a separate control period setting.
- Setting the Loop 1 Control Period to 2 s
Set *_Ch1_CtlPrdCfg to 2.

Variable name	Type	Name	Function
*_Ch1_CtlPrdCfg	UINT	Loop 1 Control Period	Output Period in PID Control
*_Ch2_CtlPrdCfg	UINT	Loop 2 Control Period	Output Period in PID Control

3-7 Setting the Set Points

Set the set point (SP) in the device variables for CJ-series Unit Loop 1 and 2 Set point (*_Ch1_SetPointCfg, *_Ch2_SetPointCfg). (See the following table.)

Variable name	Type	Name	Function
*_Ch1_SetPointCfg	INT	Loop 1 Set point	Set the set point of loop 1.
*_Ch2_SetPointCfg	INT	Loop 2 Set point	Set the set point of loop 2.

Example) To change the loop 1 Set point from 0 °C to 200 °C, set *_Ch1_SetPointCfg to 200.

Changing the set point is not enough to start temperature control, it is also necessary for the Stop Bit for that loop to be OFF. Refer to 3-12 *Starting and Stopping Temperature Control* for details.

3-8 Using ON/OFF Control

With ON/OFF control, you set a set point in advance. During reverse operation, the Temperature Controller will turn OFF the control output when the set point is reached. When the control output goes OFF, the system temperature will begin to drop and the control output will be turned ON again when the system temperature falls below the set point. This ON/OFF operation is repeated around the set point.

The control sensitivity setting determines how far the system temperature has to fall below the set point before the control output is turned ON again. Also, the control operation setting determines whether the Unit operates with forward operation (cooling) or reverse operation (heating). With forward operation, the manipulated variable increases as the PV increases; with reverse operation, the manipulated variable decreases as the PV increases.

ON/OFF Control Operation

Pin 6 of the DIP switch on the front of the Unit selects whether the Temperature Control Unit uses ON/OFF control or PID control with 2 degrees of freedom. The Unit will use PID control if pin 6 is OFF; it will use ON/OFF control if pin 6 is ON. The factory setting is PID control.

Control Sensitivity

In ON/OFF control, the ON and OFF switching creates a stable hysteresis loop. The width of the hysteresis loop is called the control sensitivity.

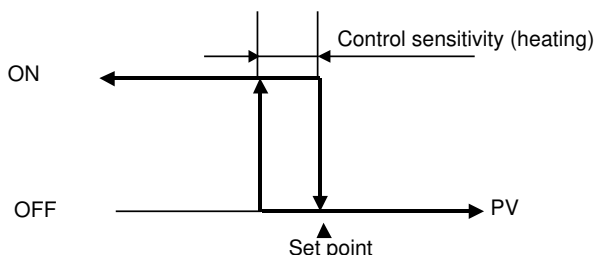

Example Settings

Set the control method, set point, and control sensitivity for the use of ON/OFF control.

In this example, ON/OFF control is used for loop 1. The set point is 200°C and the control sensitivity is 2°C.

- Turn ON pin 6 of the DIP switch on the front of the Unit. (The new setting will be read when the Unit is restarted or the controller is reset, including when the power is turned ON.)
- Set device variable for CJ-series Unit Loop 1 Set point (**_Ch1_SetPointCfg*) to 200. See 3-7 *Setting the Set Points* for details.
- Set device variable for CJ-series Unit Loop 1 Control Sensitivity (**_Ch1_CtlHysrstsCfg*) to 20.

Variable name	Type	Name	Function
<i>*_Ch1_CtlHysrstsCfg</i>	UINT	Loop 1 Control Sensitivity	Enabled only during ON/OFF control.
<i>*_Ch2_CtlHysrstsCfg</i>	UINT	Loop 2 Control Sensitivity	Enabled only during ON/OFF control.

3-9 Setting the PID Constants

Setting PID Constants with Autotuning

The autotuning (AT) function can be used to automatically calculate the optimal PID constants for the set point during operation. This Temperature Control Unit uses the limit cycle method, which determines the controlled system's characteristics by forcibly changing the manipulated variable. Autotuning cannot be started if the Unit is stopped or using ON/OFF control operation.

● Starting Autotuning

- To start autotuning, turn the device variables for CJ-series Unit Loop 1 and 2 Start AT Bit (**_Ch1_StartATCmd*, **_Ch2_StartATCmd*) from 0 to 1.
- When autotuning is completed, you must replace the current PID constants with the calculated PID constants in order for the Unit to operate with the calculated PID constants. The Unit stores the calculated PID constants in the Read PID Constants in the Operating Parameters and turns ON the PID Constants Calculated Flag at the same time. Use this flag as an input condition in the CPU Unit's user program and transfer the read PID constants from the Operating Parameters to the word in the Operating Parameters where the Setting PID constants are stored.

After the PID constants have been transferred, turn the Change PID Constants Bit from 0 to 1. Toggling this control bit causes the Temperature Controller's PID constants to be refreshed with the new Setting PID constants.

Read PID Constant

Variable name	Type	Name	Function
<i>*_Ch1_ProportionalBandSta</i>	UINT	Loop 1 Proportional Band for Monitor	---
<i>*_Ch2_ProportionalBandSta</i>	UINT	Loop 2 Proportional Band for Monitor	---
<i>*_Ch1_IntgTmSta</i>	UINT	Loop 1 Integral Time for Monitor	---
<i>*_Ch2_IntgTmSta</i>	UINT	Loop 2 Integral Time for Monitor	---
<i>*_Ch1_DerivativeTmSta</i>	UINT	Loop 1 Derivative Time for Monitor	---
<i>*_Ch2_DerivativeTmSta</i>	UINT	Loop 2 Derivative Time for Monitor	---

Setting PID Constant

Variable name	Type	Name	Function
<i>*_Ch1_ProportionalBandCfg</i>	UINT	Loop 1 Proportional Band	---
<i>*_Ch2_ProportionalBandCfg</i>	UINT	Loop 2 Proportional Band	---
<i>*_Ch1_IntgTmCfg</i>	UINT	Loop 1 Integral Time	---
<i>*_Ch2_IntgTmCfg</i>	UINT	Loop 2 Integral Time	---
<i>*_Ch1_DerivativeTmCfg</i>	UINT	Loop 1 Derivative Time	---
<i>*_Ch2_DerivativeTmCfg</i>	UINT	Loop 2 Derivative Time	---

● Stopping Autotuning

- To stop autotuning, change device variables for CJ-series Unit Loop 1 and 2 Stop AT Bit (**_Ch1_StopATCmd*, **_Ch2_StopATCmd*) from 0 to 1.
- Only the Stop Bit and Stop AT Bit settings can be changed while autotuning is being executed. Settings changed during autotuning will be enabled when autotuning is completed.
- If the Stop Bit is turned ON while autotuning is being executed, autotuning will be interrupted and operation will stop. Autotuning will not restart when operation is restarted with the Stop Bit.

Setting PID Constants Manually

Set "Proportional Band (P)", "Integral Time (I)" and "Derivative Time (D)" of the Setting PID Constants for the use of manually set PID constants.



Additional Information

- When you already know the system's control characteristics, set the PID constants directly to adjust the control characteristics. Set the three PID constants: The proportional band (P), integral time (I), and derivative time (D).
- The Unit will operate with basic proportional operation if the integral time (I) and derivative time (D) are set to 0. If the factory settings are used, the proportional band will produce a manipulated variable of 0.0% at the set point.

Example PID Control Application

● Procedure

In this example, autotuning is executed for loop 1 and loop 1 operates using PID control with two degrees of freedom.

First, execute Autotuning (AT).

- 1** Start autotuning by turning the device variable for CJ-series Unit Loop 1 Start AT Bit (**_Ch1_StartATCmd*) from 0 to 1.

Next, perform PID constants calculation.

- 2** When autotuning is completed, the calculated PID constants will be stored in the Read PID Constants.

At the same time, the Loop 1 PID Constants Calculated Flag (**_Ch1_PIDCalcFlg*) will be turned ON. Use this bit as an input condition in the CPU Unit's user program and transfer the Read PID Constants to Setting PID Constants.

- 3** After the PID constants have been transferred to the output area by the user program, turn the Loop 1 change PID Constants Bit (**_Ch1_ChgPIDCmd*) from 0 to 1.

The Temperature Control Unit will read the Setting PID Constants.

The PID Constants Calculated Flag (**_Ch1_PIDCalcFlg*) will be turned from 1 to 0 automatically when you turn the Change PID Constants Bit (**_Ch1_ChgPIDCmd*) from 0 to 1.

Refer to *A-4 Sample Programming* for an example user program that performs the steps outlined above.

● Timing Chart

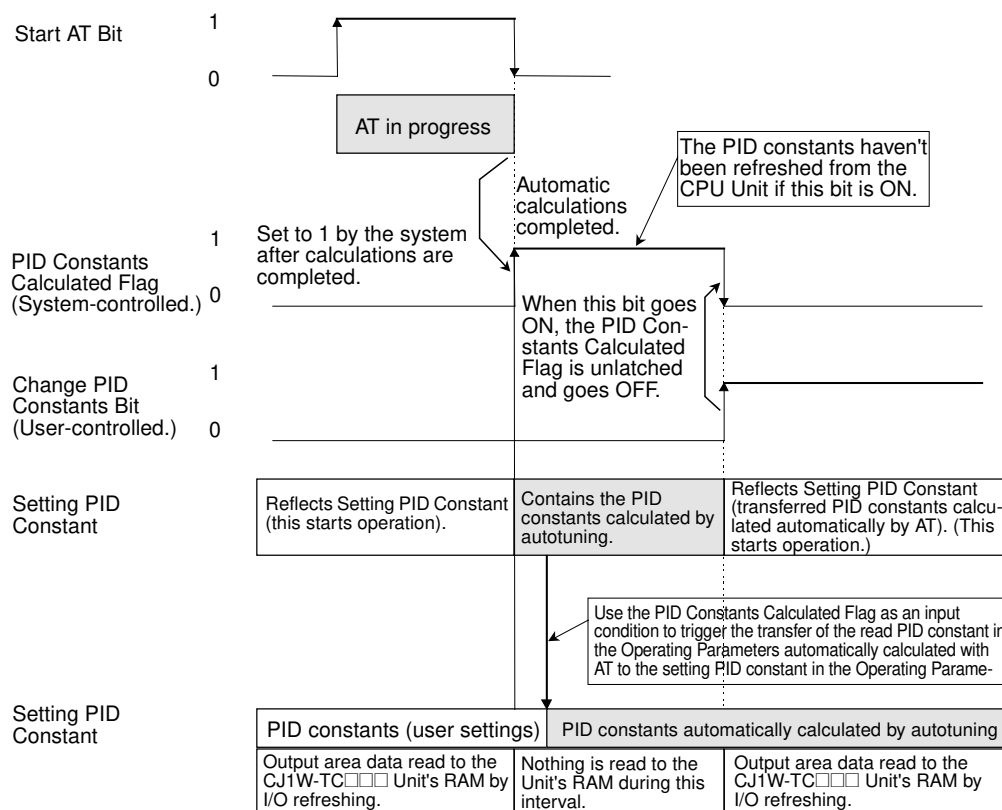

Additional Information

Effects of Changes to the PID Constants

The following tables show the effects on the PV when each PID constant is changed (increased or decreased.)

• Changing P (The Proportional Band)

Increasing P	SP		It takes longer to reach the set point (SP), but the process value (PV) does not overshoot.
Decreasing P	SP		The PV overshoots and there is hunting, but the PV reaches the SP quickly.

• Changing I (The Integral Time)

Increasing I	SP		It takes longer to reach the SP, but hunting, overshooting and undershooting are reduced.
Decreasing I	SP		Overshooting and undershooting occur. Hunting occurs. The PV rises quickly.

- Changing D (The Derivative Time)

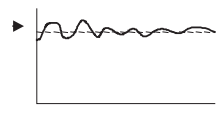
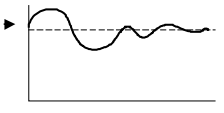
Increasing D	<p>SP </p>	Overshooting, undershooting, and the set time are reduced, but hunting will occur from small changes in the system itself.
Decreasing D	<p>SP </p>	Overshooting and undershooting are increased. It takes time to return to the SP.

3-10 Using the Alarm Output Function

This section explains the alarm modes, standby sequence, and alarm values.

Setting the Alarm Mode (Initialization Data)

There are two alarm outputs for each loop and any of the following nine alarm modes can be selected for each alarm's operation.

To use the alarm output function, set a value in the Loop 1, 2 Alarm 1 Mode and Alarm 2 Mode (*_AlmMd) of the device variable for CJ-series Unit. Set the Alarm Mode for each loop.

If the alarm mode setting is changed, the new setting will not become effective until the controller is reset or the Unit is restarted. Always reset the controller or restart the Unit after changing the alarm mode.

● Alarm Modes

In the following diagrams, the "X" indicates the alarm SV. The factory setting is "0."

Setting	Alarm mode	Alarm output function	
		Alarm SV (X) is positive	Alarm SV (X) is negative
0	No alarm	Output OFF	
1	Upper and lower-limit alarm		Always ON
2	Upper-limit alarm		
3	Lower-limit alarm		
4	Upper and lower-limit range alarm		Always OFF
5	Upper and lower-limit alarm with standby sequence		Always OFF
6	Upper-limit alarm with standby sequence		
7	Lower-limit alarm with standby sequence		
8	Absolute-value upper-limit alarm		
9	Absolute-value lower-limit alarm		

Setting the Alarm Hysteresis (Initialization Data)

The hysteresis setting controls the ON/OFF switching of the alarm output, as shown in the following diagram. This setting can be changed in the Initialization Data words allocated in the DM Area to the Temperature Control Unit.

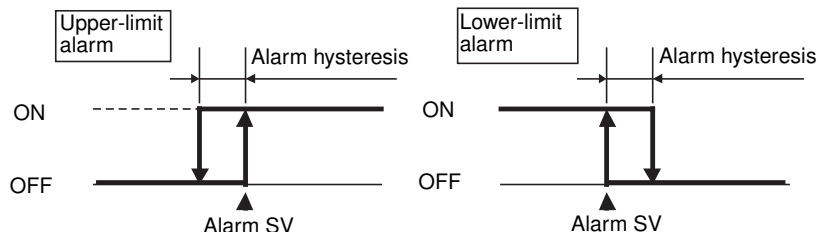

Set device variables for CJ-series Unit "Alarm 1 Hysteresis" (`*_Ch1_AL1HystrsCfg`, `*_Ch2_AL1HystrsCfg`) and "Alarm 2 Hysteresis" (`*_Ch1_AL2HystrsCfg`, `*_Ch2_AL2HystrsCfg`) independently for each alarm. The standard setting is 0.2.

If the alarm hysteresis settings are changed, the new setting will not become effective until the controller is reset or the Unit is restarted. Always reset the controller or restart the Unit after changing these settings.

Setting the Alarm SVs (Operating Parameters)

The Alarm SVs are indicated by "X" in the Alarm Modes table in *3-10 Using the Alarm Output Function*.

Set values in device variables for CJ-series Unit "Alarm 1 SV" (`*_Ch1_AL1LvICfg`, `*_Ch2_AL1LvICfg`) and "Alarm 2 SV" (`*_Ch1_AL2LvICfg`, `*_Ch2_AL2LvICfg`).



Additional Information

About the Standby Sequence

The "standby sequence" disables the alarm output once the PV leaves the alarm range. The alarm output will not function until the PV re-enters the alarm range.

For example with the standard "lower-limit alarm" mode, the PV is usually lower than the set point when the power is turned ON, so the PV is within the alarm range and the alarm output goes ON. If Lower-limit Alarm with Standby Sequence Mode is selected, the alarm will not be output until after the PV rises above the alarm SP, leaves the alarm range, and then falls below the alarm SP again.

Restarting the Standby Sequence

The standby sequence will be cleared once the PV leaves the alarm range, but the standby sequence will restart (reset) in the following situations:

- At the start of operation (when the controller is restarted or reset, including when the power is turned ON), when the alarm SV, input compensation values, or set point is changed
- When the alarm SV, input calculated values, or set point is changed
- When the Output OFF Flag turns OFF

Summary of Alarm Operation

The following timing chart shows the operation of alarms with a standby sequence. In this example, the alarm mode is Upper and Lower-limit Alarm with Standby Sequence.

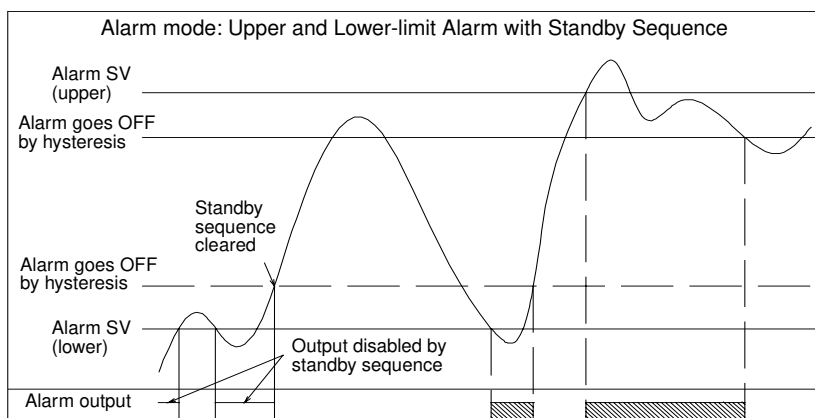

Example Alarm Settings

● Alarm Mode and Alarm Hysteresis

The alarm mode and alarm hysteresis for loops 1 and 2 are set as shown in the following table.

Loop	Alarm	Alarm mode	Hysteresis
Loop 1	Alarm 1	3: Lower-limit alarm	2.0°C
	Alarm 2	2: Upper-limit alarm	0.5°C
Loop 2	Alarm 1	1: Upper and lower-limit alarm	1.0°C
	Alarm 2	8: Absolute-value lower-limit alarm	2.0°C

- 1** Set "Loop 1, 2 Alarm 1 Mode and Alarm 2 Mode" (*_AlmMd) to "16#3218".
- 2** Set hysteresis values in "Alarm Hysteresis" (*_Ch1_AL1HystrsCfg, *_Ch2_AL1HystrsCfg, *_Ch1_AL2HystrsCfg and *_Ch2_AL2HystrsCfg).
- 3** To enable the new settings, reset the controller or restart the Unit.

● Setting Alarm 1 SV of Loop 2 to 20 °C

Set "Loop 2 Alarm 1 SV" (*_Ch2_AL1LvICfg) to 20.

Summary of Alarm Output Function Settings

Variable name	Type	Name	Function
*_AlmMd	WORD	Loop 1, 2 Alarm 1 Mode and Alarm 2 Mode	Set the Alarm 1 Mode and Alarm 2 Mode of loop 1 and loop 2. 0: No alarm 1: Upper and lower-limit alarm 2: Upper-limit alarm 3: Lower-limit alarm 4: Upper and lower-limit range alarm 5: Upper and lower-limit alarm with standby sequence 6: Upper-limit alarm with standby sequence 7: Lower-limit alarm with standby sequence 8: Absolute-value upper-limit alarm 9: Absolute-value lower-limit alarm
*_Ch1_AL1HystrsCfg	UINT	Loop 1 Alarm 1 Hysteresis	Set the loop 1 alarm hysteresis.
*_Ch1_AL2HystrsCfg	UINT	Loop 1 Alarm 2 Hysteresis	
*_Ch2_AL1HystrsCfg	UINT	Loop 2 Alarm 1 Hysteresis	Set the loop 2 alarm hysteresis.
*_Ch2_AL2HystrsCfg	UINT	Loop 2 Alarm 2 Hysteresis	
*_Ch1_AL1LvlCfg	INT	Loop 1 Alarm 1 SV	Set the loop 1 detection level.
*_Ch1_AL2LvlCfg	INT	Loop 1 Alarm 2 SV	
*_Ch2_AL1LvlCfg	INT	Loop 2 Alarm 1 SV	Set the loop 2 detection level.
*_Ch2_AL2LvlCfg	INT	Loop 2 Alarm 2 SV	

3-11 Using the Heater Burnout Alarm

Heater Burnout Detection

- Follow this procedure to detect heater burnout (an open heating wire).

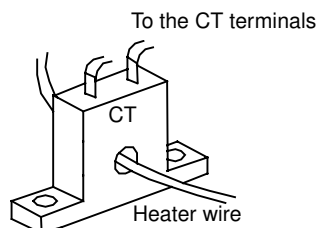

- 1 Pass the heater wire through the hole in the Current Transformer (CT). Refer to *Current Transformer (CT) Ratings* in 2-1 Specifications and A-1 Dimensions for details on the specifications, model numbers, and dimensions.
- 2 When current flows through the heater wire, it induces an AC current in the Current Transformer (CT) that is proportional to the current in the heater wire. The current flowing through the heater can be determined from the current induced in the CT.
- 3 The current will drop if there is a heater burnout and the heater burnout alarm (HB output) will be turned ON if the current falls below the preset heater burnout current.
- 4 The HB output is a latched output. To release the latch (i.e., turn OFF the HB output), either set the heater burnout current to 0.0, reset the controller, or restart the Temperature Control Unit.

- Note**
- 1 Do not use any CT other than the OMRON E54-CT1 or E54-CT3 Current Transformer.
 - 2 Set the desired heater burnout detection current in the Heater Burnout Current word. The value in the Heater Current Monitor word can be used to check the CT's current.
 - 3 Set the heater burnout current to 0.0 if you are not using the heater burnout detection function.
 - 4 The heater burnout current is set independently for each loop.

Operating Conditions

- Connect the CT and pass the heater wire through the CT in advance.
- Turn ON the heater's power supply before the Temperature Control Unit or turn ON both at the same time. The heater burnout alarm will be output if the heater's power supply is turned ON after the Temperature Control Unit.
- Temperature control will continue even if a heater burnout is detected, so that the Unit can continue controlling heaters that have not burned out.
- Heater burnout detection will operate when the control output has been ON continuously for more than 200 ms.
- Sometimes the heater's rated current does not match the current that actually flows through the heater. Use the heater current monitor to check the current during actual use.
- Heater burnout detection will be unstable if there is only a small difference between the normal current and heater burnout current. For stable operation, set a minimum difference of 1.0 A with heaters drawing less than 10.0 A or a minimum difference of 2.5 A with heaters drawing 10.0 A or more.

- The heater burnout detection function cannot be used if the heater is being controlled with the position control method or cycle control method. Also, the heater burnout detection function cannot be used with three-phase heaters.

Note To detect heater burnout in a three-phase heater, use a K2CU-F□□A-□GS (with gate input terminals). Refer to the catalog for more details.

Determining the Heater Burnout Current

- Use the following equation to calculate the average of the normal current and the current with a heater burnout:

$$SV = \frac{\text{Current in normal operation} + \text{current after heater burnout}}{2}$$

- If more than one heater is connected through the CT, set the heater burnout current to the current induced when the heater with the smallest current consumption is burned out. If the heaters all consume the same current, set the heater burnout current to the current induced when one of the heaters is burned out.
- The difference between the normal current and the heater burnout current must meet the following minimum levels:

Heaters drawing less than 10.0 A:

Normal current – current with heater burnout ≥ 1.0 A

(Operation will be unstable with a difference less than 1.0 A.)

Heaters drawing 10.0 A or more:

Normal current – current with heater burnout ≥ 2.5 A

(Operation will be unstable with a difference less than 2.5 A.)

- The set value range for the heater burnout current is 0.1 to 49.9 A. Heater burnout will not be detected if the heater burnout current is set to 0.0 or 50.0 A. The heater burnout alarm will be OFF if the heater burnout current is set to 0.0; it will be ON if the heater burnout current is set to 50.0.
- The total heater current during normal operation must not exceed 50.0 A.

Example Applications

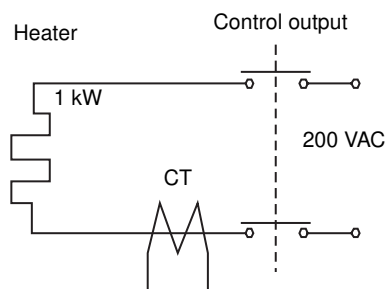

Example 1:

A single 1-kW 200-VAC heater is controlled through OUT1.

$$\text{Normal current} = \frac{1,000}{200} = 5 \text{ A } (< 10 \text{ A})$$

Current when control output is OFF = 0 A

$$SV = \frac{5 + 0}{2} = 2.5 \text{ A}$$

Normal current - control-OFF current = 5 - 0 = 5 A
(Operation will be stable with difference ≥ 1.0 A.)

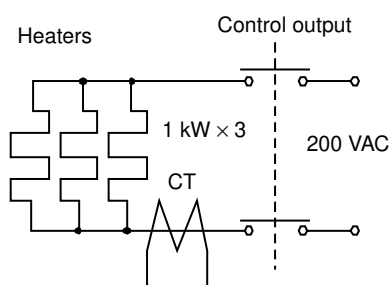

Example 2:

Three 1-kW 200-VAC heaters are controlled through OUT2.

$$\text{Normal current} = \frac{1,000 \times 3}{200} = 15 \text{ A } (\geq 10 \text{ A})$$

$$\text{Current with 1 burnout} = \frac{1,000 \times 2}{200} = 10 \text{ A}$$

$$SV = \frac{15 + 10}{2} = 12.5 \text{ A}$$

Normal current - control-OFF current = 15 - 10 = 5 A
(Operation will be stable with difference ≥ 2.5 A.)

3-12 Starting and Stopping Temperature Control

To start temperature control for a loop that has been stopped, turn device variables for CJ-series Unit "Stop Bit" (**_Ch1_StopCtlCmd* and **_Ch2_StopCtlCmd*) to OFF.

To stop temperature control for the loop, turn ON the Stop Bit.

- The factory setting of the bits is OFF (running).

● Starting Loop 1 and Stopping Loop 2

- To start control in loop 1 and stop control in loop 2, turn OFF "Loop 1 Stop Bit" (**_Ch1_StopCtlCmd*) and turn ON "Loop 2 Stop Bit" (**_Ch2_StopCtlCmd*).

4

Optional Settings

This section explains how to use the input compensation value.

4-1	Shifting the Input Value (Input Compensation)	4-2
4-2	Recovering from Sensor Not Connected Errors	4-3

4-1 Shifting the Input Value (Input Compensation)

- The input value is shifted by the "input compensation value" for all points in the sensor's range. For example, if the input compensation value is set to 1.2°C and the original process value is 200°C, the value after compensation will be 201.2°C.

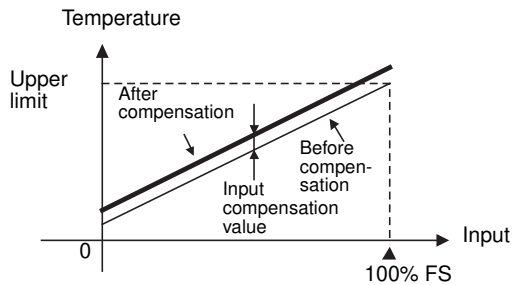

- The factory setting of the input compensation value is 0.0 for all loops.

● Example Application

- In Figure 1, the temperature sensor is some distance from the workpiece that is being controlled and the reading from the temperature sensor must be adjusted to reflect the actual temperature at the workpiece. (The reading from thermometer (B) shows the true temperature at the workpiece (C).)
- The input compensation value is just the difference between the workpiece's temperature (B) and the Temperature Control Unit's reading (A). Figure 2 shows the process values before and after compensation.

$$\text{Input Compensation Value} = \text{Workpiece's temp. (B)} - \text{Unit's reading (A)}$$
- After setting the input compensation value, compare the temperature displayed on the Unit (A) with the temperature indicated by thermometer (B). The input compensation value is correct if the two readings are approximately equal.

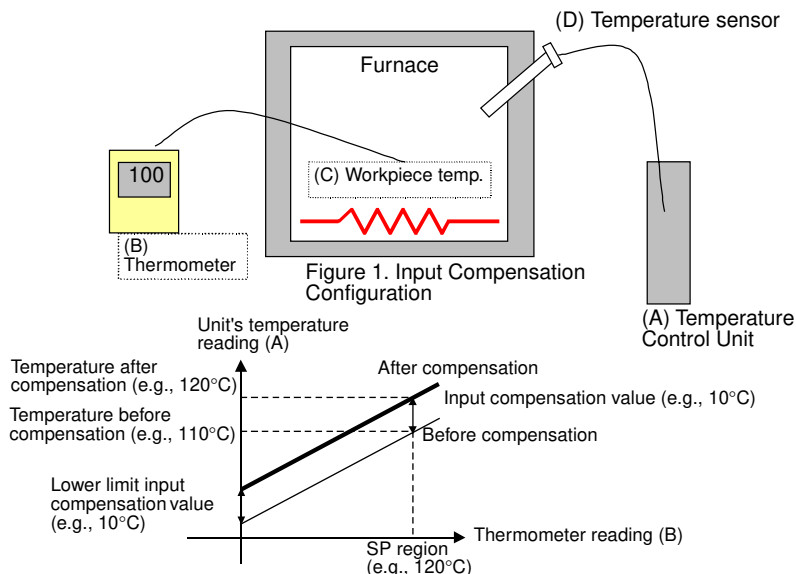

Figure 2. Compensation Graph of 1-point Compensation

4-2 Recovering from Sensor Not Connected Errors

If a sensor is not connected for any loop, a sensor error will occur and the ERC indicator on the front panel of the Unit will light. When necessary, the control and alarm functions for any loop can be disabled. The status will be as follows.

- The ERC indicator will not light to indicate sensor errors for the loop. (Refer to 5-1 *Error and Alarm Processing*.)
- Control will not be performed for the loop.
- Alarms will not be given for the loop.
- Temperatures will be input for the loop.

To disable the control and alarm functions of a certain loop, set both Alarm Mode 1 and Alarm Mode 2 of each loop of device variables for CJ-series Unit "Loop 1, 2 Alarm 1 Mode and Alarm 2 Mode" (*_AlmMd) to 16#F (i.e.,16#FF).

DM Area address	Bits															
	15	14	13	12	11	10	09	08	07	06	05	04	03	02	01	00
*_AlmMd	Loop 1								Loop 2							
	Alarm mode 1				Alarm mode 2				Alarm mode 1				Alarm mode 2			

Example) To disable loop 2, set "Loop 1, 2 Alarm 1 Mode and Alarm 2 Mode" (*_AlmMd) to 16#FF. (In this case, Alarm Mode 1 and Alarm Mode 2 of loop 1 are set to 0.)

5

Error and Alarm Processing

This section provides information on troubleshooting and error processing.

5-1 Error and Alarm Processing	5-2
5-2 Troubleshooting	5-10
5-3 Event Logs	5-16
5-3-1 Overview of the Event Logs	5-16
5-3-2 Error Table	5-17
5-3-3 Error Descriptions	5-18

5-1 Error and Alarm Processing

Identifying Errors with the Indicators

The ERC Indicator or ERH Indicator will light if an alarm or error occurs in the Temperature Control Unit.

(Front of Temperature Control Unit)

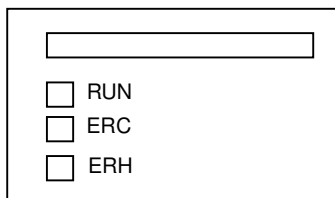

Indicator	Name	Color	Status	Meaning
RUN	RUN Indicator	Green	Lit	The Temperature Control Unit is operating normally.
			Not lit	The Temperature Control Unit is stopped.
ERC	Temperature Control Unit Error	Red	Lit	An error occurred in the Temperature Control Unit itself.
			Not lit	There is no error in the Temperature Control Unit.
ERH	CPU Unit Error	Red	Lit	An error occurred in the CPU Unit.
			Not lit	There is no error in the CPU Unit.

Error Processing Flowchart

Use the following flowchart to identify the error when an error has occurred in the Temperature Control Unit.

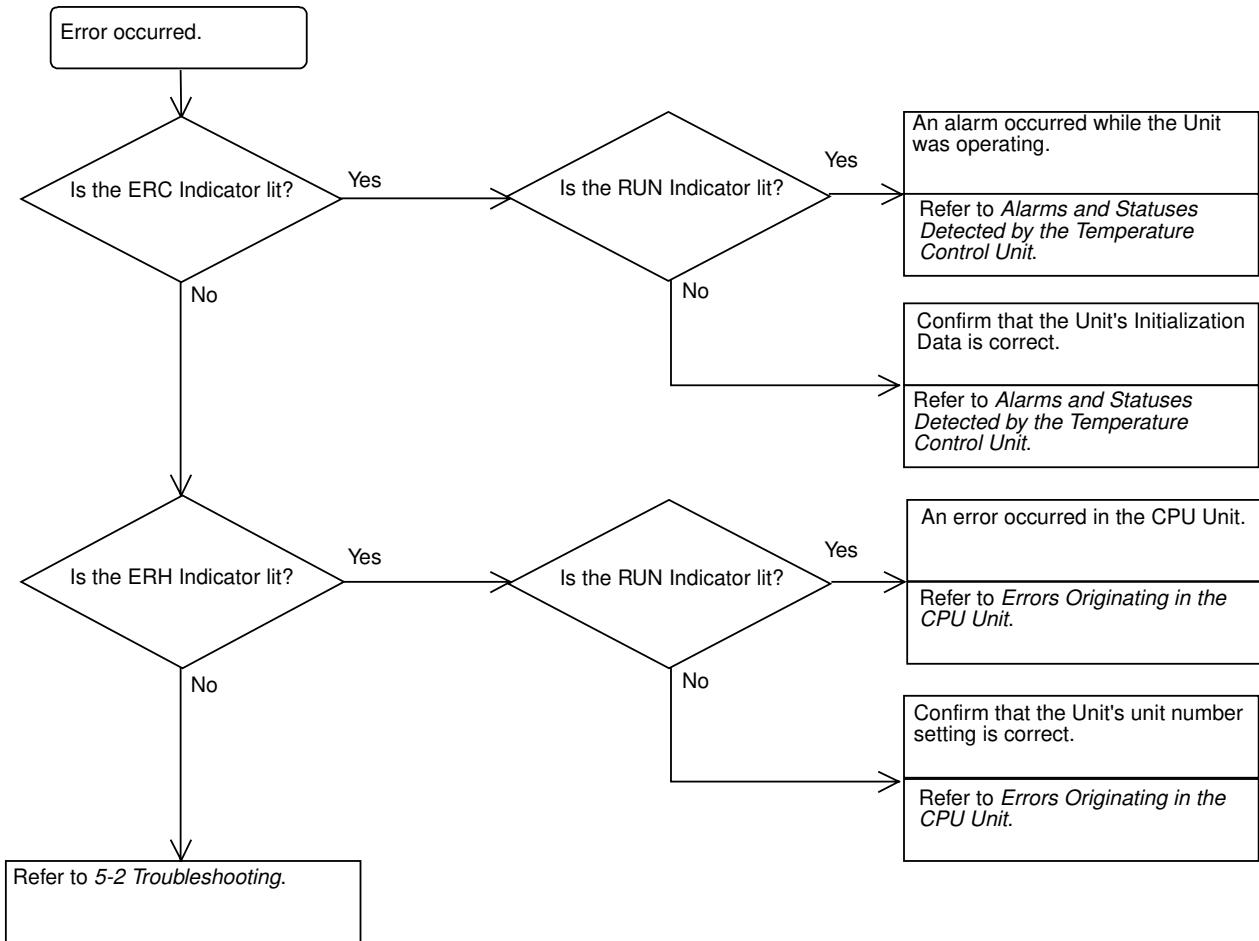

Alarms and Statuses Detected by the Temperature Control Unit

ERC indicator lights when an alarm occurs detected by the Temperature Control Unit itself. At this time, an alarm flag of the device variable for CJ-series Unit (for operation) is stored.

Bits	Name of device variable for CJ-series Unit	Type	R/W	Name	Function
*_Ch1_StaWd		WORD	R	Loop 1 Status	Bits serve the functions described below. Each bit is defined with a BOOL data type variable. Bit 00: Loop 1 AL2 Flag Bit 01: Loop 1 AL1 Flag Bit 02: Loop 1 HB Flag Bit 03: Loop 1 AT Flag Bit 04: Loop 1 Control Output Flag Bit 05: Bit 06: Bit 07: Bit 08: Loop 1 Stop Flag Bit 09: Loop 1 Setting Error Flag Bit 10: Loop 1 PID Constants Calculated Flag Bit 11: Loop 1 Standby Flag Bit 12: Loop 1 Cold Junction Sensor Error Bit 13: Loop 1 CT Overflow Flag Bit 14: Loop 1 Sensor Error Flag Bit 15: Loop 1 Save Completed Flag
00	*_Ch1_AL2Flg	BOOL	R	Loop 1 AL2 Flag	The value becomes 1 when the temperature is within the alarm range set with the input value of loop 1. The value becomes 0 when outside the alarm range.
01	*_Ch1_AL1Flg	BOOL	R	Loop 1 AL1 Flag	The value becomes 1 when the temperature is within the alarm range set with the input value of loop 1. The value becomes 0 when outside the alarm range.
02	*_Ch1_HBFlg	BOOL	R	Loop 1 HB Flag	The value becomes 1 when the heater current detection value falls below the Heater Burnout Current.
03	*_Ch1_ATFlg	BOOL	R	Loop 1 AT Flag	The value becomes 1 during Autotuning (AT) of loop 1. The value becomes 0 when Autotuning (AT) stops or finishes.
04	*_Ch1_CtlOutFlg	BOOL	R	Loop 1 Control Output Flag	The value becomes 1 during output of loop 1 Control Output.
08	*_Ch1_StopFlg	BOOL	R	Loop 1 Stop Flag	The value becomes 0 when temperature control of loop 1 executes and 1 when control stops.
09	*_Ch1_SetErr	BOOL	R	Loop 1 Setting Error Flag	The value becomes 1 when there is an error in the set value set as a device variable for CJ-series Unit.

Bits	Name of device variable for CJ-series Unit	Type	R/W	Name	Function
10	*_Ch1_PIDCalcFlg	BOOL	R	Loop 1 PID Constants Calculated Flag	The value becomes 1 when PID constants calculated by the Temperature Control Unit with AT are updated. When this bit is 1, PID constants of the OUT Area of Operating Parameters are not imported into the Temperature Control Unit. When the bit is 0, PID constants of the OUT Area of Operating Parameters are imported into the Temperature Control Unit.
11	*_Ch1_StbyFlg	BOOL	R	Loop 1 Standby Flag	The value becomes 1 when the Temperature Control Unit is waiting for I/O refreshing after the Controller is reset or the Unit is restarted.
12	*_Ch1_CJErr	BOOL	R	Loop 1 Cold Junction Sensor Error	The value becomes 1 when: <ul style="list-style-type: none"> • Cold junction sensor error occurs.
13	*_Ch1_CTOvfFlg	BOOL	R	Loop 1 CT Overflow Flag	The value becomes 1 when the heater current of the CT (current detector) exceeds 55.0 A.
14	*_Ch1_SensErr	BOOL	R	Loop 1 Sensor Error Flag	The value becomes 1 when: <ul style="list-style-type: none"> • Sensor is not connected to loop 1. • Sensor of loop 1 disconnects. • Input temperature exceeds the measurement temperature range.
15	*_Ch1_SaveFlg	BOOL	R	Loop 1 Save Completed Flag	The value becomes 1 when you select save loop 1 (change from 0 to 1) and data is written to the non-volatile memory. This flag initializes to 0 when Loop 1 Save changes from 1 to 0 (however, the value is 0 immediately after a controller reset).
*_Ch2_StaWd		WORD	R	Loop 2 Status	Bits serve the functions described below. Each bit is defined with a BOOL data type variable. Bit 00: Loop 2 AL2 Flag Bit 01: Loop 2 AL1 Flag Bit 02: Loop 2 HB Flag Bit 03: Loop 2 AT Flag Bit 04: Loop 2 Control Output Flag Bit 05: Bit 06: Bit 07: Bit 08: Loop 2 Stop Flag Bit 09: Loop 2 Setting Error Flag Bit 10: Loop 2 PID Constants Calculated Flag Bit 11: Loop 2 Standby Flag Bit 12: Loop 2 Cold Junction Sensor Error Bit 13: Loop 2 CT Overflow Flag Bit 14: Loop 2 Sensor Error Flag Bit 15: Loop 2 Save Completed Flag

Bits	Name of device variable for CJ-series Unit	Type	R/W	Name	Function
00	*_Ch2_AL2Flg	BOOL	R	Loop 2 AL2 Flag	The value becomes 1 when the temperature is within the alarm range set with the input value of loop 2. The value becomes 0 when outside the alarm range.
01	*_Ch2_AL1Flg	BOOL	R	Loop 2 AL1 Flag	The value becomes 1 when the temperature is within the alarm range set with the input value of loop 2. The value becomes 0 when outside the alarm range.
02	*_Ch2_HBFlg	BOOL	R	Loop 2 HB Flag	The value becomes 1 when the heater current detection value falls below the Heater Burnout Current.
03	*_Ch2_ATFlg	BOOL	R	Loop 2 AT Flag	The value becomes 1 during Autotuning (AT) of loop 2. The value becomes 0 when Autotuning (AT) stops or finishes.
04	*_Ch2_CtlOutFlg	BOOL	R	Loop 2 Control Output Flag	The value becomes 1 during output of loop 2 Control Output.
08	*_Ch2_StopFlg	BOOL	R	Loop 2 Stop Flag	The value becomes 0 when temperature control of loop 2 executes and 1 when control stops.
09	*_Ch2_SetErr	BOOL	R	Loop 2 Setting Error Flag	The value becomes 1 when there is an error in the setting value set as a device variable for CJ-series Unit
10	*_Ch2_PIDCalcFlg	BOOL	R	Loop 2 PID Constants Calculated Flag	The value becomes 1 when PID constants calculated by the Temperature Control Unit with AT are updated. When this bit is 1, PID constants of the OUT Area of Operating Parameters are not imported into the Temperature Control Unit. When the bit is 0, PID constants of the OUT Area of Operating Parameters are imported into the Temperature Control Unit.
11	*_Ch2_StbyFlg	BOOL	R	Loop 2 Standby Flag	The value becomes 1 when the Temperature Control Unit is waiting for I/O refreshing after the Controller is reset or the Unit is restarted.
12	*_Ch2_CJErr	BOOL	R	Loop 2 Cold Junction Sensor Error	The value becomes 1 when: <ul style="list-style-type: none"> • Cold junction sensor error occurs.
13	*_Ch2_CTOvfFlg	BOOL	R	Loop 2 CT Overflow Flag	The value becomes 1 when the heater current of the CT (current detector) exceeds 55.0 A.
14	*_Ch2_SensErr	BOOL	R	Loop 2 Sensor Error Flag	The value becomes 1 when: <ul style="list-style-type: none"> • Sensor is not connected to loop 2. • Sensor of loop 2 disconnects. • Input temperature exceeds the measurement temperature range.
15	*_Ch2_SaveFlg	BOOL	R	Loop 2 Save Completed Flag	The value becomes 1 when you select save loop2 (change from 0 to 1) and data is written to the non-volatile memory. This flag initializes to 0 when Loop 2 Save changes from 1 to 0 (however, the value is 0 immediately after a controller reset).

ERC Indicator Lit and RUN Indicator Lit

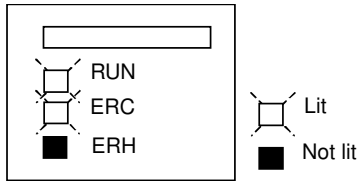

These alarms indicate that an incorrect operation was performed while the Unit was operating normally. These alarms are cleared automatically when the cause of the alarm is corrected.

If pin 1 of the Temperature Control Unit's DIP Switch is OFF (stop operation when CPU Unit is in PROGRAM mode), the RUN Indicator will be OFF when the CPU Unit is in PROGRAM mode.

	*_Ch1_SensErr *_Ch2_SensErr	*_Ch1_CTOvfFlg *_Ch2_CTOvfFlg	*_Ch1_SetErr *_Ch2_SetErr	*_Ch1_HBFlg *_Ch2_HBFlg
Error	Sensor Error	CT Overflow	Setting Error	Heater Burnout Alarm
Cause	An input error has occurred.	The heater current is above 55.0 A.	There is an error in a setting.	A heater circuit has burned out.
Control status	<ul style="list-style-type: none"> Control operation continues (Output OFF). Alarm operates as if the temperature is out of range. 	Control operation continues.	The incorrect set value will be ignored and operation will continue with the set values retained in the Temperature Control Unit.	Control operation continues.
Processing	Check for incorrect input wiring, disconnection, short-circuit, and incorrect input type setting.	The heater current value will be correct when the current is within range.	Check the "Setting Error Number" in *_DecPointSetErrSta. Correct the indicated setting.	Check the heater and repair the heater where the burnout occurred.

Setting Error Numbers

Setting error number	Setting name	Priority
0	No incorrect settings	-
1	Alarm mode 1	1
2	Alarm mode 2	2
3	Alarm 1 hysteresis	3
4	Alarm 2 hysteresis	4
5	Set point	5
6	Alarm 1 SV	6
7	Alarm 2 SV	7
8	Input compensation value	8
9	Control period	9
A	Control sensitivity	10
B	Proportional band	11
C	Integral time	12
D	Derivative time	13
E	Heater burnout current	14
F	Not allocated	15

When there are errors in two or more settings, the setting error number with the highest priority will be stored.

ERC Indicator Lit and RUN Indicator Not Lit

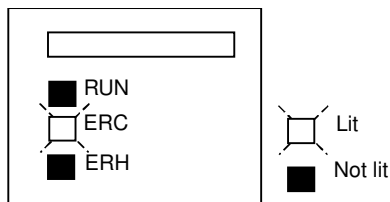

These alarms indicate that there is an error in the Unit's Initialization Data.

When one of these alarms occurs, correct the cause of the alarm and then clear the alarm by restarting the Unit, or resetting the controller including turning ON the power.

Error	Cause	Control status	Processing
Hardware Check Error	An error occurred in the Unit's peripheral hardware.	Control operation will stop.	<ul style="list-style-type: none"> Restart the Unit or reset the controller (including by turning ON the power). If the error is in non-volatile memory, turn ON pin 7 of the Unit's DIP Switch to initialize the settings. If these steps do not clear the error, repair or replace the Unit.
Cold Junction Sensor Error	An error occurred in the cold junction sensor.	Control operation will stop.	Check the connections at the cold junction sensor on the terminal block and restart the Unit or reset the controller, including by turning ON the power.
DM Setting Error (Initialization Data)	There is an error in the Initialization Data settings.	Control operation will stop.	Check the location of the error, correct the initialization data (alarm mode or alarm hysteresis), and then restart the Unit, or reset the controller including by turning ON the power.

Errors Originating in the CPU Unit

The ERH Indicator will light when the Temperature Control Unit cannot operate normally because I/O refreshing is not being performed properly with Special I/O Units. An error in the CPU Unit or I/O bus can interfere with I/O refreshing.

● ERH Indicator Lit and RUN Indicator Lit

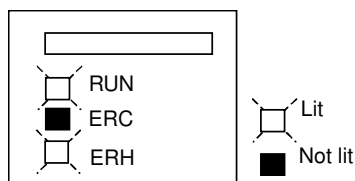

The ERH and RUN Indicators will both be lit when I/O refreshing is not being performed properly between the CPU Unit and the Temperature Control Unit due to an error in the I/O bus or a WDT (watchdog timer) error in the CPU Unit. Turn the Controller power supply OFF and ON.

For details, refer to the *NJ-series CPU Unit Hardware User's Manual* (Cat. No. W500).

Error	Cause	Control status	Processing
CPU Unit Monitor Error	A response was not returned from the CPU Unit within the fixed interval.	Control operation will continue.	Check the I/O refreshing interval.

ERH Indicator Lit and RUN Indicator Not Lit

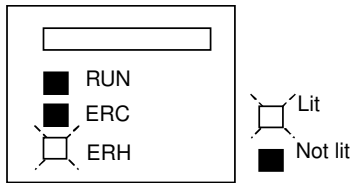

If there is an error in the Temperature Control Unit's unit number setting or if I/O refreshing cannot be performed properly with the Temperature Control Unit because of an I/O bus error or WDT (watchdog timer) error in the CPU Unit, only the EHR Indicator will light.

Error	Cause	Control status	Processing
Duplicate Unit Number	The Temperature Control Unit's unit number is duplicated on another Special I/O Unit or is not within the allowed range (00 to 94). (The Temperature Control Unit occupies two unit numbers for one unit.)	Control operation will stop.	Correct the unit number settings. Turn the Controller power supply OFF and ON.
I/O Setting Check Error	The Special I/O Units registered in the Unit Configuration in the CPU Unit are different from the ones actually mounted.		
I/O Bus Check Error	An error occurred in the transfer of data between the CPU Unit and another Unit.		Check that the sliders connect all of the Units securely and the End Cover is locked. Turn the Controller power supply OFF and ON.
CPU Unit WDT Error	An error occurred in the CPU Unit		

Unit Restart

To resume operation after changing settings in the Initialization Data or removing the cause of errors, restart the Unit with one of the methods described below.

Initialization Data will be updated after restart.

- Reset the Controller from Sysmac Studio.
- Reset the Controller by turning the Controller power supply OFF and ON.
- Restart using the ResetUnit instruction of the program.
- Restart using a system-defined variable.

Variable name	Type	
<code>_CJB_SIO**Restart</code>	BOOL	Unit number 00 to 94 in **



Precautions for Correct Use

- If the error persists after the restart, replace this Unit.
- During restart, output is 0 V as the data immediately before restart is maintained for input.

5-2 Troubleshooting

If some problem develops with the Temperature Control Unit, use the following procedure to isolate and correct the problem.

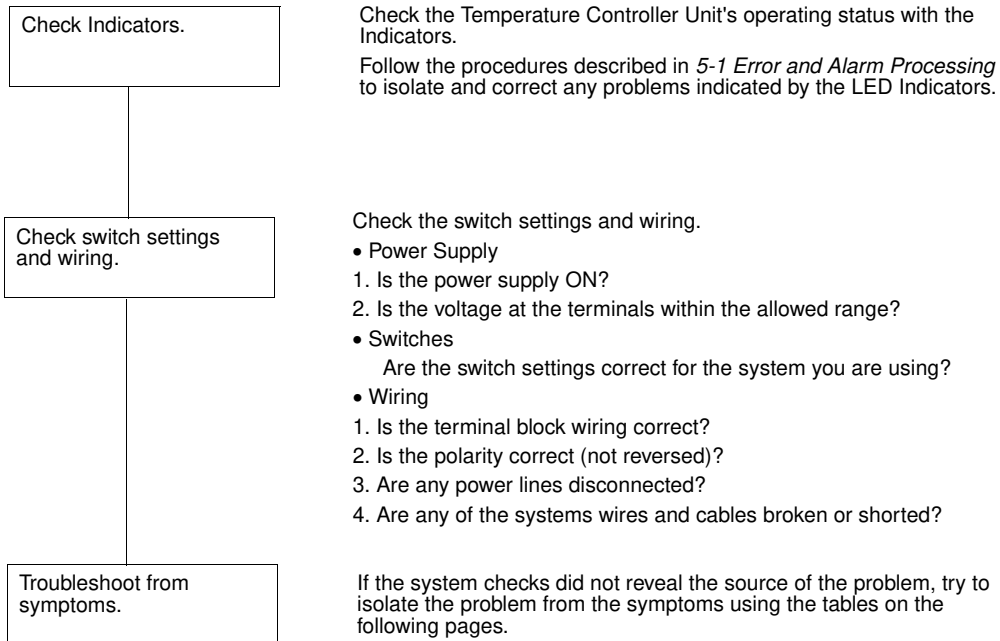

Troubleshooting from Symptoms: Measurement Errors

● Incorrect Measurement or No Measurement

Step	Possible Cause	Remedy
Connection	The temperature sensor is connected to the wrong terminals or polarity is reversed.	Wire temperature sensor correctly.
	The temperature sensor connected to the Temperature Control Unit is not compatible with the Unit.	Replace the temperature sensor with one that is compatible with the Temperature Control Unit.
	The temperature sensor wires are broken, short-circuited, or damaged.	Replace the temperature sensor with a good one.
	No temperature sensor is connected.	Connect a temperature sensor.
	The compensating conductor being used is not compatible with the thermocouple.	<ul style="list-style-type: none"> • Directly connect a thermocouple with long lead wires. • Use a compensating conductor that is compatible with the thermocouple.
	Some equipment is connected between the thermocouple and Temperature Control Unit that uses metal different than the metal in the compensating conductor or thermocouple.	The equipment used for connections must be made specifically for use with thermocouples.
	The terminal screws are loose so there is poor contact between the wires and terminals.	Tighten the terminal screws.
	The thermocouple's lead wires or the compensating conductors are too long, so the resistance in the wires is affecting operation.	<ul style="list-style-type: none"> • Use thicker compensating conductors. • Change the wiring location to reduce the length of the wiring.
	The conductors between the temperature sensor and the Temperature Control Unit's terminals have three different conductive resistances.	Use conductors with the same resistance for the A, B, and B' terminals.
Installation	Noise from electric equipment around the Temperature Control Unit is affecting operation.	<ul style="list-style-type: none"> • Move the Temperature Control Unit away from the equipment that is generating the noise. • Install surge protectors or noise filters on the equipment that is generating the noise.
	The temperature sensor's leads run close to power lines, so noise is being induced from the power lines.	<ul style="list-style-type: none"> • Separate the temperature sensor's leads from the power lines. • Run the temperature sensor's leads in a conduit or duct separate from the one carrying the power lines. • Do not run the temperature sensor's leads parallel to the power lines. • Reduce the length of the temperature sensor's leads. • Use shielded wire for the temperature sensor's leads.
	The temperature sensor is installed too far from the point being controlled, so the response to temperature changes is delayed.	Install the temperature sensor in a protective tube closer to the point being controlled.
	The ambient temperature where the Temperature Control Unit is installed exceeds the Unit's ratings.	Install the Temperature Control Unit in a location with an ambient temperature between 0 and 55°C.
	Wireless equipment is being used near the Temperature Control Unit.	Shield the Temperature Control Unit.
	The temperature around the Temperature Control Unit is not uniform because of heat-generating equipment near the Unit.	Move the Temperature Control Unit to a location where it won't be affected by heat-generating equipment.
	There is a draft (breeze) on the Temperature Control Unit's terminal block.	Eliminate or block the draft.

Step	Possible Cause	Remedy
Settings	The Input Type setting is incorrect.	Set the Input Type correctly.
	The Temperature Units setting is incorrect.	Set the Temperature Units correctly.
	The measured temperature appears to be shifted because of the Input Compensation Value setting.	Set the Input Compensation Value to 0.0.
	The data storage/display format setting is incorrect.	• Check the "data storage/display format" of pin 3 of the DIP switch and correct the user program.
	The user program of the Host System is not correct.	• Always set pin 3 of the DIP switch to ON when connected with the NJ series.
Usage	There is a thermocouple input and the input terminals are shorted.	Connect a thermocouple.
	The temperature sensor was replaced or switch settings were changed while the power was ON.	Turn the power OFF and then ON again.



Additional Information

Here is a simple method to check the temperature sensor inputs:

With a resistance-thermometer Unit, connect a 100- Ω resistor to the A-B temperature sensor input terminals and short the B-B terminals. The Temperature Control Unit is operating normally if the measured temperature is at the 0.0°C or 32.0°F level.

With a thermocouple Unit, short the temperature sensor input terminals. The Temperature Control Unit is operating normally if the measured temperature is the temperature in the vicinity of the terminal block.

Troubleshooting from Symptoms: Temperature Control Errors

● Temperature Does Not Rise

Step	Possible Cause	Remedy
Connection	The measured temperature is incorrect.	Refer to <i>Troubleshooting from Symptoms: Measurement Errors</i> for troubleshooting directions.
	There is no load connected to the control output terminals.	Connect a load.
	The load's polarity is reversed or the load is wired to the wrong terminals.	Wire the load correctly.
	The terminal screws are loose so there is poor contact between the wires and terminals.	Tighten the terminal screws.
	The heater's power supply is not ON.	Turn ON the heater's power supply.
	The heater circuit is burned out or damaged.	Replace the heater with a good one.
	The heater's heat output is insufficient.	• Replace the heater with one that has a higher output. • When using two or more heaters, check whether one is burned out. Replace if necessary.
	An overheating protection device is operating.	Increase the overheating protection device's temperature setting so it is higher than the Temperature Controller Unit's set point.
Settings	The forward operation/reverse operation setting is incorrect	Correct the setting.
	The PID constant settings are not correct.	• Perform autotuning. • Make the correct PID constant settings manually.
	Temperature control has not been started.	Start temperature control.
	A cooling fan is operating.	Turn OFF the cooling fan.

Measured Temperature Higher than Control Temperature

Step	Possible Cause	Remedy
Connection	The measured temperature is incorrect.	Refer to <i>Troubleshooting from Symptoms: Measurement Errors</i> for troubleshooting directions.
	The load is connected to the wrong control loop, so the heater is being controlled by another loop's control output.	Wire the load correctly.
	The contacts are fused in the relay operated by the control output.	Replace the relay with a good one.
	There is a short circuit in the relay operated by the control output.	Replace the relay with a good one.
	Current is flowing to the heater because of leakage current through the relay operated by the control output.	Connect a bleeder resistor to prevent operation due to the leakage current.
Settings	The forward operation/reverse operation setting is incorrect.	Correct the setting.
	The PID constant settings are not correct.	<ul style="list-style-type: none"> Perform autotuning. When autotuning is completed, refresh the PID constants properly so that the Unit operates with the calculated PID constants. Make the correct PID constant settings manually.
Usage	There is excessive overshooting.	Refer to <i>Excessive Overshooting or Undershooting</i> for troubleshooting directions.

Excessive Overshooting or Undershooting

Step	Possible Cause	Remedy
Connection	The measured temperature is incorrect.	Refer to <i>Troubleshooting from Symptoms: Measurement Errors</i> for troubleshooting directions.
	A general-purpose temperature sensor is being used in a system with a very fast heating response.	Change to a sheathed sensor.
Settings	The proportional band is narrow because PID constant P is too small.	<ul style="list-style-type: none"> Increase the P constant to a level that produces an acceptable response delay. Perform autotuning.
	The integral time is short because PID constant I is too small.	<ul style="list-style-type: none"> Increase the I constant to a level that produces an acceptable response delay. Perform autotuning.
	The derivative time is short because PID constant D is too small.	<ul style="list-style-type: none"> Increase the D constant to a level that produces acceptable stability. Perform autotuning.
	ON/OFF control is being used.	Use P (proportional) control or PID control.
	A long control period has been set in a system with a very fast heating response.	Reduce the control period.
	Autotuning was performed, but the Temperature Control Unit's PID constants were not refreshed with the calculated PID constants.	Refresh the Temperature Control Unit's PID constants with the calculated PID constants. Refer to <i>3-9 Setting the PID Constants</i> for details.

Excessive Hunting

The same connection and settings problems can cause overshooting, undershooting, and hunting. Refer to *Excessive Overshooting or Undershooting* for details on possible connection and settings problems.

Step	Possible Cause	Remedy
Usage	The heater's output is too large for the controlled system.	Use a heater that is suitable for the controlled system.
	Something disturbs the system periodically and changes its heating requirement.	Arrange the controlled system to minimize external disturbances.
	Autotuning is in progress.	The hunting will stop when autotuning is completed.

Troubleshooting from Symptoms: Output Errors

● No Control Output or No Alarm Output

Step	Possible Cause	Remedy
Connection	The measured temperature is incorrect.	Refer to <i>Troubleshooting from Symptoms: Measurement Errors</i> for troubleshooting directions.
	The load's polarity is reversed or the load is wired to the wrong terminals.	Wire the load correctly.
	The connected load exceeds the output ratings.	<ul style="list-style-type: none"> Use a load within the output's ratings. Repair the load if it is malfunctioning.
	A load power supply is not connected to the transistor output.	Provide a power supply that is suitable for the output ratings and load.
	The polarity is reversed to the transistor output's load power supply.	Wire the power supply correctly.
Settings	Temperature control has not been started.	Turn OFF the Stop Bit.
	The wrong loop number is specified.	Make settings for the correct loop number.
	The loop is disabled. (Alarm mode 1 and alarm mode 2 are set to FF.)	Set an alarm mode. Refer to <i>3-10 Using the Alarm Output Function</i> for details.
	The set point is incorrect.	Set the correct set point.
	The alarm mode is set to 0 (no alarm).	Set the correct alarm mode.
	An alarm with a standby sequence has been set.	Set an alarm mode without a standby sequence.
	A deviation alarm or absolute value alarm has been set incorrectly.	Set the correct alarm mode.

Troubleshooting from Symptoms: HB Alarm Errors

● Heater Burnout Not Detected

Step	Possible Cause	Remedy
Connection	A Current Transformer (CT) is not connected.	Connect a CT.
	The CT is connected to the wrong channel.	Input the CT correctly.
	The heater is being operating with another output, i.e., one from an Output Unit.	Change the wiring to control output that corresponds to the CT input.
	The connected CT is not an OMRON E54-CT1 or E54-CT3.	CTs other than the OMRON E54-CT1 and E54-CT3 cannot be used. Connect an E54-CT1 or E54-CT3.
Settings	Temperature control has not been started.	Start temperature control.
	The control output's ON time is less than 200 ms.	The heater burnout alarm will operate when the control output's ON time is longer than 200 ms.
	The heater's power supply was turned ON after temperature control was started.	Start temperature control after the heater's power supply has been turned ON.
	The heater burnout current is set to 0.0 or 50.0 A.	Set the appropriate heater burnout current between 0.1 and 49.9 A
	The heater burnout current is based on the heater's rated current.	Take an actual measurement of the heater's current to determine the appropriate heater burnout current.
	The heater burnout current from the actual measurement is not appropriate.	Consider the voltage range of the heater's power supply and current measurement error. Set the heater burnout current again.
Usage	The heater current exceeds 50.0 A.	Use a heater current of 50.0 A or less.
	The heater current is DC.	The heater burnout alarm cannot be used with a DC heater.
	A pure metallic heater is being used.	Take an actual measurement of the heater's current to determine the appropriate heater burnout current.

5-3 Event Logs

5-3-1 Overview of the Event Logs

You use the same methods to manage all of the events that occur on the NJ-series Controller. (The events include errors and information.) You can use the Sysmac Studio or an NS-series PT to confirm current Controller events and the logs of events that have occurred. These logs are called event logs. Controller errors that occur for this Unit are also reported as events in the NJ-series CPU Unit.

Refer to the *NJ-series CPU Unit Software User's Manual* (Cat. No. W501) for details on the event logs in an *NJ-series CPU Unit*. Refer to the *NJ-series Troubleshooting Manual* (Cat. No. W503) for details on Controller errors, confirmation methods, and corrections.

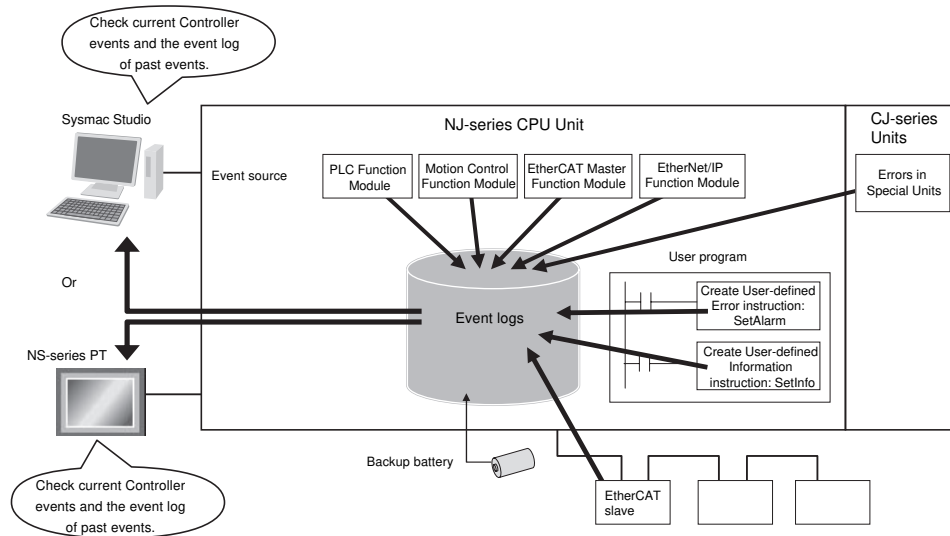

To use an NS-series PT to check events, connect the PT to the built-in EtherNet/IP port on the CPU Unit.

5-3-2 Error Table

The errors that may occur for this Unit are listed below.

The following abbreviations and symbols are used in the event level column.

Abbreviation	Name
Maj	Major fault level
Prt	Partial fault level
Min	Minor fault level
Obs	Observation
Info	Information

Symbol	Meaning
S	Event levels that are defined by the system.
U	Event levels that can be changed by the user.*

* This symbol appears only for events for which the user can change the event level.

A version in parentheses in the *Event code* column is the unit version of the CPU Unit when the event was added.

Refer to the *NJ-series Troubleshooting Manual* (Cat. No. W503) for all of the event codes that may occur in an NJ-series Controller.

Event code	Event name	Meaning	Assumed cause	Level					Reference
				Maj	Prt	Min	Obs	Info	
04680000 hex	Cold Junction Sensor Error	An error occurred in the cold junction sensor.	<ul style="list-style-type: none"> Faulty connection to the cold junction sensor. The cold junction sensor failed. 			U	S		page 19
34940000 hex	Setting Error	There is an illegal setting.	<ul style="list-style-type: none"> The set value is incorrect. 			U	S		page 19
64840000 hex	Sensor Error	An error occurred in the sensor input.	<ul style="list-style-type: none"> Error in input from the Sensor. 			U	S		page 20
64850000 hex	CT Overflow	An overflow occurred in the CT input.	<ul style="list-style-type: none"> The heater current exceeded 55.0 A. 			U	S		page 20
64860000 hex	Heater Burn-out Alarm	A heater burnout occurred.	<ul style="list-style-type: none"> The power supply to the heater is not ON. The heater is burned out or deteriorated. 			U	S		page 21

5-3-3 Error Descriptions

This section describes the information that is given for individual errors.

Controller Error Descriptions

The items that are used to describe individual errors (events) are described in the following copy of an error table.

Event name	Gives the name of the error.		Event code	Gives the code of the error.		
Meaning	Gives a short description of the error.					
Source	Gives the source of the error.		Source details	Gives details on the source of the error.	Detection timing	Tells when the error is detected.
Error attributes	Level	Tells the level of influence on control.*1	Recovery	Gives the recovery method.*2	Log category	Tells which log the error is saved in.*3
Effects	User program	Tells what will happen to execution of the user program.*4	Operation	Provides special information on the operation that results from the error (event).		
System-defined variables	Variable	Data type		Name		
	Lists the variable names, data types, and meanings for system-defined variables that provide direct error notification, that are directly affected by the error, or that contain settings that cause the error.					
Cause and correction	Assumed cause		Correction		Prevention	
	Lists the possible causes, corrections, and preventive measures for the error.					
Attached information	This is the attached information that is displayed by the Sysmac Studio or an NS-series PT.					
Precautions/Remarks	Provides precautions, restrictions, and supplemental information. If the user can set the event level, the event levels that can be set, the recovery method, operational information, and other information are also provided.					

*1 One of the following:

Major fault: Major fault level
 Partial fault: Partial fault level
 Minor fault: Minor fault level
 Observation
 Information

*2 One of the following:

Automatic recovery: Normal status is restored automatically when the cause of the error is removed.
 Error reset: Normal status is restored when the error is reset after the cause of the error is removed.
 Cycle the power supply: Normal status is restored when the power supply to the Controller is turned OFF and then back ON after the cause of the error is removed.
 Controller reset: Normal status is restored when the Controller is reset after the cause of the error is removed.
 Depends on cause: The recovery method depends on the cause of the error.

*3 One of the following:

System: System event log
 Access: Access event log

*4 One of the following:

Continues: Execution of the user program will continue.
 Stops: Execution of the user program stops.
 Starts: Execution of the user program starts.

Error Descriptions

Event name	Cold Junction Sensor Error			Event code	04680000 hex	
Meaning	An error occurred in the cold junction sensor.					
Source	PLC Function Module		Source details	CJ-series Unit	Detection timing	Continuously
Error attributes	Level	Observation	Recovery	---	Log category	System
Effects	User program	Continues.	Operation	Control operations of the Unit will stop.		
System-defined variables	Variable		Data type		Name	
	None		---		---	
Cause and correction	Assumed cause		Correction		Prevention	
	Faulty connection to the cold junction sensor.		Check the connections to the cold junction sensor (i.e., terminal block), reconnect it if the connection is faulty, and then cycle the power supply or restart the Unit.		Securely connect the cold junction sensor (i.e., terminal block).	
	The cold junction sensor failed.		If the cause is not a faulty connection, replace the Temperature Control Unit.		None	
Attached information	Attached information 1: Loop number where error was detected					
Precautions/Remarks	You can change the event level to the minor fault level. If you change the level to the minor fault level, the <i>Recovery</i> column above will be changed to "Error reset."					

Event name	Setting Error			Event code	34940000 hex	
Meaning	There is an illegal setting.					
Source	PLC Function Module		Source details	CJ-series Unit	Detection timing	Continuously for operating data and operation adjustment data, or at power ON or Controller reset for initial setting data
Error attributes	Level	Observation	Recovery	---	Log category	System
Effects	User program	Continues.	Operation	Operating data or operation adjustment data: The set value that caused the error at the Unit will be ignored. Operation will continue using the set value held in the Temperature Controller Unit. Initial setting data: Control operations of the Unit will stop.		
System-defined variables	Variable		Data type		Name	
	None		---		---	
Cause and correction	Assumed cause		Correction		Prevention	
	The set value is incorrect.		Check the content of the setting error number in the lower byte of device variable <i>*_DecPointSetErrSta</i> and correct the settings. If you correct the initial setting data, cycle the power supply, reset the Controller, or restart the Unit.		Check and correct the settings.	
Attached information	Attached information 1: Loop number where error was detected					
Precautions/Remarks	You can change the event level to the minor fault level. If you change the level to the minor fault level, the <i>Recovery</i> column above will be changed to "Error reset."					

5 Error and Alarm Processing

Event name	Sensor Error		Event code	64840000 hex		
Meaning	An error occurred in the sensor input.					
Source	PLC Function Module		Source details	CJ-series Unit	Detection timing	Continuously
Error attributes	Level	Observation	Recovery	---	Log category	System
Effects	User program	Continues.	Operation	Control operations will continue. Control outputs for the loop of the Unit will stop. The present temperature reaches the measurement upper limit, and so the alarm operation will be performed due to the high temperature.		
System-defined variables	Variable		Data type		Name	
	None		---		---	
Cause and correction	Assumed cause		Correction		Prevention	
	Error in input from the Sensor.		Check the input for incorrect wiring, disconnection, or short circuits, and correct any problems. Or, correct the input type setting if the input type setting is incorrect.		Check for incorrect wiring, broken wires, and short circuits.	
Attached information	Attached information 1: Loop number where error was detected					
Precautions/Remarks	You can change the event level to the minor fault level. If you change the level to the minor fault level, the <i>Recovery</i> column above will be changed to "Error reset."					

Event name	CT Overflow		Event code	64850000 hex		
Meaning	An overflow occurred in the CT input.					
Source	PLC Function Module		Source details	CJ-series Unit	Detection timing	Continuously
Error attributes	Level	Observation	Recovery	---	Log category	System
Effects	User program	Continues.	Operation	Not affected.		
System-defined variables	Variable		Data type		Name	
	None		---		---	
Cause and correction	Assumed cause		Correction		Prevention	
	The heater current exceeded 55.0 A.		Set the CT input so that it does not exceed 55.0 A.		Set the CT input so that it does not exceed 55.0 A.	
Attached information	Attached information 1: Loop number where error was detected					
Precautions/Remarks	You can change the event level to the minor fault level. If you change the level to the minor fault level, the <i>Recovery</i> column above will be changed to "Error reset."					

Event name	Heater Burnout Alarm			Event code	64860000 hex	
Meaning	A heater burnout occurred.					
Source	PLC Function Module		Source details	CJ-series Unit	Detection timing	Continuously
Error attributes	Level	Observation	Recovery	---	Log category	System
Effects	User program	Continues.	Operation	Not affected.		
System-defined variables	Variable		Data type		Name	
	None		---		---	
Cause and correction	Assumed cause		Correction		Prevention	
	The power supply to the heater is not ON.		Turn ON the power supply to the heater.		When you use the Temperature Controller Unit, turn ON the power supply to the connected heater.	
	The heater is burned out or deteriorated.		If the above causes does not apply, replace the heater.		None	
Attached information	Attached information 1: Loop number where error was detected					
Precautions/Remarks	You can change the event level to the minor fault level. If you change the level to the minor fault level, the <i>Recovery</i> column above will be changed to "Error reset."					

App

Appendices

A-1	Dimensions	A-2
A-2	Functional Differences due to CPU Units (NJ/CJ-series) to be Connected	A-3
A-3	Correspondence Table of Device Variables for CJ-series Unit and Memory Used for CJ-series Unit Addresses	A-4
A-4	Sample Programming	A-10

A-1 Dimensions

All dimensions are in mm.

CJ1W-TC□□□

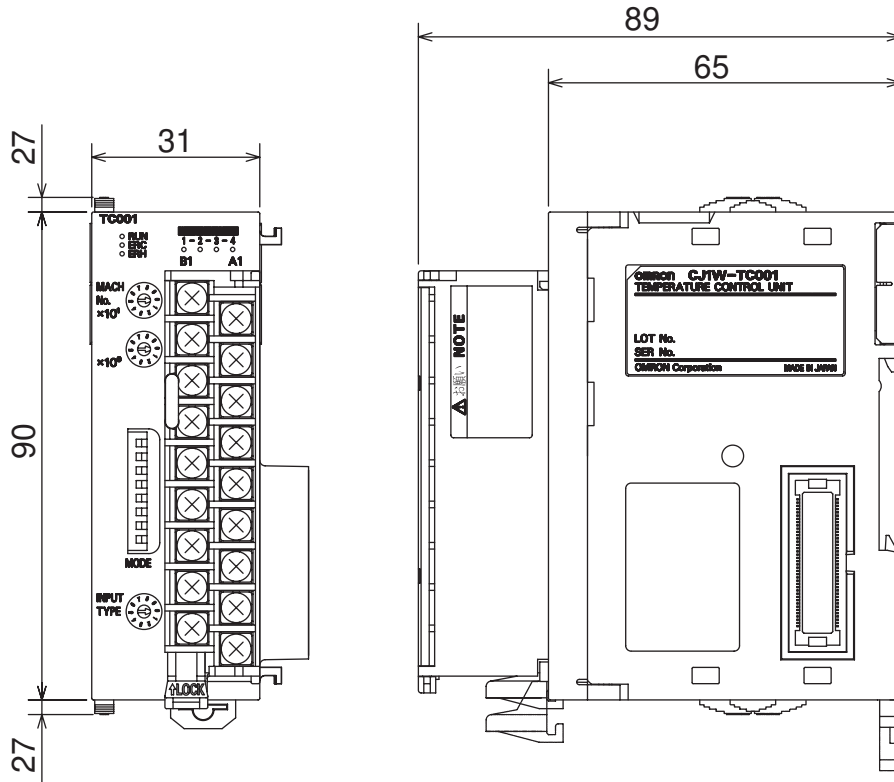

Current Transformer (Sold Separately)

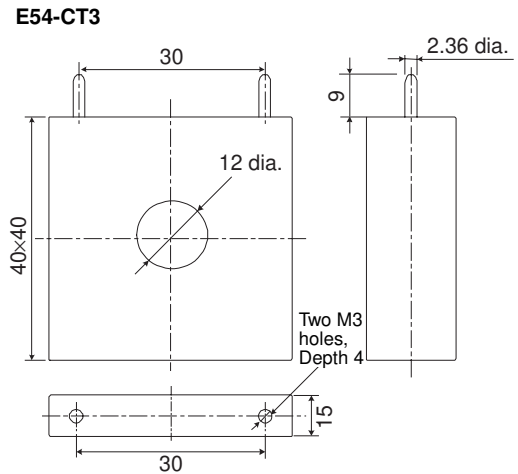
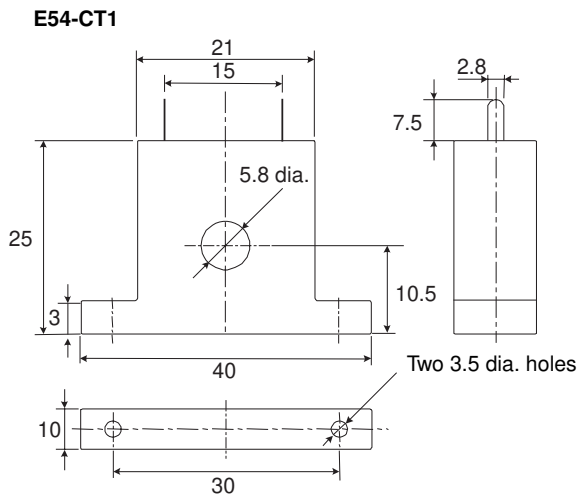

A-2 Functional Differences due to CPU Units (NJ/CJ-series) to be Connected

This Unit can be used with NJ-series CPU Units.

If this Unit is used with the NJ Series, some functions become unavailable compared to when it is used with the CJ series.

The following explains how each function of this Unit changes when a CJ-series CPU Unit is connected, compared when an NJ-series CPU Unit is connected.

Name		Use with NJ-series	Use with CJ-series
Model		CJ1W-TC003/004 CJ1W-TC103/104	CJ1W-TC001/002/003/004 CJ1W-TC101/102/103/104
Unit type		SYSMAC CJ-series Special I/O Unit	
Applied PLC		SYSMAC NJ Series	SYSMAC CJ Series
Number of control loops		2 loops (with Heater Burnout Alarm)	2 loops (with Heater Burnout Alarm) or 4 loops
Control input		Thermocouple (R, S, K, J, T, B, L) Resistance thermometer (JPt100, Pt100)	
Control Mode		PID or ON/OFF PID: 2 degrees of freedom with Autotuning (AT)	
Control output		CJ1W-TC□03: Open collector (NPN) output (pulse) External 24-VDC power supply CJ1W-TC□04: Open collector (PNP) output (pulse) External 24-VDC power supply	CJ1W-TC□01/□03: Open collector (NPN) output (pulse) External 24-VDC power supply CJ1W-TC□02/□04: Open collector (PNP) output (pulse) External 24-VDC power supply
Setting accuracy Instruction accuracy	Thermocouple input	±0.3% or ±1 °C (whichever is larger) ±1 digit or less	
	Resistance thermometer input	±0.3% or ±0.8 °C (whichever is larger) ±1 digit or less	
Data storage/display format of data exchanged with CPU Unit		16-bit binary only (variable) Use with pin 3 of the DIP switch set to ON.	BCD or 16-bit binary (selectable) Set with pin 3 of the DIP switch. OFF: BCD, ON: Binary
RUN/STOP control		Supported	
Operation during CPU Unit PROGRAM mode		Continue or stop operating (selectable)	
Autotuning (AT) of PID constant		Can be started and stopped	
Sampling period		500 ms	
Input compensation value		-99.9 to 999.9 °C/°F	
Output wiring method		Terminal block	
Heater Burnout Detection		Available (2 loop type only)	
CT heater detection current		0.0 to 50.0 A	
Setting write memory		Non-volatile Memory (100,000 writes) or RAM	

A-3 Correspondence Table of Device Variables for CJ-series Unit and Memory Used for CJ-series Unit Addresses

If this Unit is used with an NJ-series CPU Unit, the user program uses device variables for CJ-series Unit that reference the memory used for CJ-series Unit to use the functions.

The correspondence tables for word addresses, bit positions and device variables for CJ-series Unit between the I/O memory of the CJ-series CPU Unit and memory used for CJ-series Unit of the NJ-series CPU Unit are shown below.

Start address of special I/O Unit area: $n = 2000 \text{ words} + \text{Unit number} \times 10$ (Unit number: 0 to 94)

Start address of special I/O Unit DM area: $m = D20000 + \text{Unit number} \times 100$ (Unit number: 0 to 94)

Set the CIO and DM area words allocated to the Unit by using the unit number switches on the front panel of the Unit.

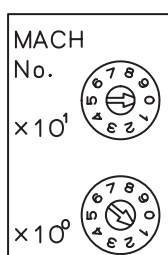

Switch No.	Unit No.	Special I/O Unit area allocated CIO number	Data Memory (DM) Area allocated DM number
0	Unit 0	CIO 2000 to CIO 2019	D20000 to D20099
1	Unit 1	CIO 2010 to CIO 2029	D20100 to D20199
2	Unit 2	CIO 2020 to CIO 2039	D20200 to D20299
3	Unit 3	CIO 2030 to CIO 2049	D20300 to D20399
4	Unit 4	CIO 2040 to CIO 2059	D20400 to D20499
5	Unit 5	CIO 2050 to CIO 2069	D20500 to D20599
6	Unit 6	CIO 2060 to CIO 2079	D20600 to D20699
7	Unit 7	CIO 2070 to CIO 2089	D20700 to D20799
8	Unit 8	CIO 2080 to CIO 2099	D20800 to D20899
9	Unit 9	CIO 2090 to CIO 2109	D20900 to D20999
⋮	⋮	⋮	⋮
n	Unit n	CIO 2000+n×10 to CIO 2000+n×10+19	D20000+n×100 to D20000+n×100+99
⋮	⋮	⋮	⋮
94	Unit 94	CIO 2940 to CIO 2959	D29400 to D29499

There are two unit numbers per Temperature Control Unit. Hence, the unit numbers 0 to 94 are available. Please note that this is different from other Special I/O Units.

**Additional Information**

- If the same unit number or Special I/O Unit Area is set for more than one Special I/O Unit, a major fault level "Duplicate Unit Number" occurs and the Unit will not operate.
 - After correcting the unit number setting, turn the Controller power supply OFF and ON.
-

● Operation Data

I/O	CJ-series I/O memory address		NJ-series device variable for CJ-series Unit			
	Word No.	Bit No.	Variable name	Name	Data type	
Output (CPU Unit to this Unit)	n+0	00-15	*_Ch1_SetPointCfg	Loop 1 Set point	INT	
	n+1	00-15	*_Ch2_SetPointCfg	Loop 2 Set point	INT	
	n+2	00	00	*_Ch2_StartATCmd	Loop 2 Start AT Bit	BOOL
			01	*_Ch2_StopATCmd	Loop 2 Stop AT Bit	BOOL
			02	*_Ch1_StartATCmd	Loop 1 Start AT Bit	BOOL
			03	*_Ch1_StopATCmd	Loop 1 Stop AT Bit	BOOL
			04	*_Ch2_StopCtlCmd	Loop 2 Stop Bit	BOOL
			06	*_Ch1_StopCtlCmd	Loop 1 Stop Bit	BOOL
			12	*_Ch2_ChgPIDCmd	Loop 2 change PID Constants Bit	BOOL
			13	*_Ch1_ChgPIDCmd	Loop 1 change PID Constants Bit	BOOL
			14	*_Ch2_SaveCmd	Loop 2 Save Settings Bit	BOOL
			15	*_Ch1_SaveCmd	Loop 1 Save Settings Bit	BOOL

I/O	CJ-series I/O memory address		NJ-series device variable for CJ-series Unit			
	Word No.	Bit No.	Variable name	Name	Data type	
Input (This Unit to CPU Unit)	n+3	00-15	*_Ch1_PV	Loop 1 Process Value	INT	
	n+4	00-15	*_Ch2_PV	Loop 2 Process Value	INT	
	n+5	00-15	*_Ch1_SetPointSta	Loop 1 Set point for Monitor	INT	
	n+6	00-15	*_Ch2_SetPointSta	Loop 2 Set point for Monitor	INT	
	n+7	00-15	*_DecPointSetErrSta	Loop 1, 2 Decimal Point and Loop 1, 2 Setting Error Number	WORD	
	n+8	00-15	*_Ch1_StaWd	Loop 1 Status	Loop 1 Status	WORD
		00	*_Ch1_AL2Flg	Loop 1 AL2 Flag	Loop 1 AL2 Flag	BOOL
		01	*_Ch1_AL1Flg	Loop 1 AL1 Flag	Loop 1 AL1 Flag	BOOL
		02	*_Ch1_HBFlg	Loop 1 HB Flag	Loop 1 HB Flag	BOOL
		03	*_Ch1_ATFlg	Loop 1 AT Flag	Loop 1 AT Flag	BOOL
		04	*_Ch1_CtlOutFlg	Loop 1 Control Output Flag	Loop 1 Control Output Flag	BOOL
		08	*_Ch1_StopFlg	Loop 1 Stop Flag	Loop 1 Stop Flag	BOOL
		09	*_Ch1_SetErr	Loop 1 Setting Error Flag	Loop 1 Setting Error Flag	BOOL
		10	*_Ch1_PIDCalcFlg	Loop 1 PID Constants Calculated Flag	Loop 1 PID Constants Calculated Flag	BOOL
		11	*_Ch1_StbyFlg	Loop 1 Standby Flag	Loop 1 Standby Flag	BOOL
		12	*_Ch1_CJErr	Loop 1 Cold Junction Sensor Error	Loop 1 Cold Junction Sensor Error	BOOL
		13	*_Ch1_CTOvfFlg	Loop 1 CT Overflow Flag	Loop 1 CT Overflow Flag	BOOL
		14	*_Ch1_SensErr	Loop 1 Sensor Error Flag	Loop 1 Sensor Error Flag	BOOL
		15	*_Ch1_SaveFlg	Loop 1 Save Completed Flag	Loop 1 Save Completed Flag	BOOL
		n+9	00-15	*_Ch2_StaWd	Loop 2 Status	Loop 2 Status
	00		*_Ch2_AL2Flg	Loop 2 AL2 Flag	Loop 2 AL2 Flag	BOOL
	01		*_Ch2_AL1Flg	Loop 2 AL1 Flag	Loop 2 AL1 Flag	BOOL
	02		*_Ch2_HBFlg	Loop 2 HB Flag	Loop 2 HB Flag	BOOL
	03		*_Ch2_ATFlg	Loop 2 AT Flag	Loop 2 AT Flag	BOOL
	04		*_Ch2_CtlOutFlg	Loop 2 Control Output Flag	Loop 2 Control Output Flag	BOOL
	08		*_Ch2_StopFlg	Loop 2 Stop Bit	Loop 2 Stop Bit	BOOL
	09		*_Ch2_SetErr	Loop 2 Setting Error Flag	Loop 2 Setting Error Flag	BOOL
	10		*_Ch2_PIDCalcFlg	Loop 2 PID Constants Calculated Flag	Loop 2 PID Constants Calculated Flag	BOOL
	11		*_Ch2_StbyFlg	Loop 2 Standby Flag	Loop 2 Standby Flag	BOOL
	12		*_Ch2_CJErr	Loop 2 Cold Junction Sensor Error	Loop 2 Cold Junction Sensor Error	BOOL
	13		*_Ch2_CTOvfFlg	Loop 2 CT Overflow Flag	Loop 2 CT Overflow Flag	BOOL
	14		*_Ch2_SensErr	Loop 2 Sensor Error Flag	Loop 2 Sensor Error Flag	BOOL
15	*_Ch2_SaveFlg		Loop 2 Save Completed Flag	Loop 2 Save Completed Flag	BOOL	

I/O	CJ-series I/O memory address		NJ-series device variable for CJ-series Unit		
	Word No.	Bit No.	Variable name	Name	Data type
Output (CPU Unit to this Unit)	n+10	00-15	*_Ch1_HBLvlCfg	Loop 1 Heater Burnout Current	UINT
	n+11	00-15	*_Ch2_HBLvlCfg	Loop 2 Heater Burnout Current	UINT
Input (This Unit to CPU Unit)	n+13	00-15	*_Ch1_HtrCurVal	Loop 1 Heater Current	UINT
	n+14	00-15	*_Ch2_HtrCurVal	Loop 2 Heater Current	UINT
	n+15	00-15	*_Ch1_HBLvlSta	Loop 1 Heater Burnout Current for Monitor	UINT
	n+16	00-15	*_Ch2_HBLvlSta	Loop 2 Heater Burnout Current for Monitor	UINT

● Initialization Data

CJ-series I/O memory address		NJ-series device variable for CJ-series Unit		
DM No.	Bit No.	Variable name	Name	Data type
D(m+0)	00-15	*_AlmMd	Loop 1, 2 Alarm 1 Mode and Alarm 2 Mode	WORD
D(m+2)	00-15	*_Ch1_AL1HystrsCfg	Loop 1 Alarm 1 Hysteresis	UINT
D(m+3)	00-15	*_Ch1_AL2HystrsCfg	Loop 1 Alarm 2 Hysteresis	UINT
D(m+4)	00-15	*_Ch2_AL1HystrsCfg	Loop 2 Alarm 1 Hysteresis	UINT
D(m+5)	00-15	*_Ch2_AL2HystrsCfg	Loop 2 Alarm 2 Hysteresis	UINT

● Operating Parameter

I/O	CJ-series I/O memory address		NJ-series device variable for CJ-series Unit		
	DM No.	Bit No.	Variable name	Name	Data type
Output (CPU Unit to this Unit)	D(m+10)	00-15	*_Ch1_AL1LvlCfg	Loop 1 Alarm 1 SV	INT
	D(m+11)	00-15	*_Ch1_AL2LvlCfg	Loop 1 Alarm 2 SV	INT
	D(m+12)	00-15	*_Ch1_AllnOfsCfg	Loop 1 Input Compensation Value	INT
	D(m+13)	00-15	*_Ch1_CtlPrdCfg	Loop 1 Control Period	UINT
	D(m+14)	00-15	*_Ch1_CtlHystrsCfg	Loop 1 Control Sensitivity	UINT
	D(m+15)	00-15	*_Ch1_ProportionalBandCfg	Loop 1 Proportional Band	UINT
	D(m+16)	00-15	*_Ch1_IntgTmCfg	Loop 1 Integral Time	UINT
	D(m+17)	00-15	*_Ch1_DerivativeTmCfg	Loop 1 Derivative Time	UINT
	D(m+20)	00-15	*_Ch2_AL1LvlCfg	Loop 2 Alarm 1 SV	INT
	D(m+21)	00-15	*_Ch2_AL2LvlCfg	Loop 2 Alarm 2 SV	INT
	D(m+22)	00-15	*_Ch2_AllnOfsCfg	Loop 2 Input Compensation Value	INT
	D(m+23)	00-15	*_Ch2_CtlPrdCfg	Loop 2 Control Period	UINT
	D(m+24)	00-15	*_Ch2_CtlHystrsCfg	Loop 2 Control Sensitivity	UINT
	D(m+25)	00-15	*_Ch2_ProportionalBandCfg	Loop 2 Proportional Band	UINT
D(m+26)	00-15	*_Ch2_IntgTmCfg	Loop 2 Integral Time	UINT	
D(m+27)	00-15	*_Ch2_DerivativeTmCfg	Loop 2 Derivative Time	UINT	

I/O	CJ-series I/O memory address		NJ-series device variable for CJ-series Unit		
	DM No.	Bit No.	Variable name	Name	Data type
Input (This Unit to CPU Unit)	D(m+30)	00-15	*_Ch1_AL1LvlSta	Loop 1 Alarm 1 SV for Monitor	INT
	D(m+31)	00-15	*_Ch1_AL2LvlSta	Loop 1 Alarm 2 SV for Monitor	INT
	D(m+32)	00-15	*_Ch1_AllnOfsSta	Loop 1 Input Compensation Value for Monitor	INT
	D(m+33)	00-15	*_Ch1_CtlPrdSta	Loop 1 Control Period for Monitor	UINT
	D(m+34)	00-15	*_Ch1_CtlHysrsSta	Loop 1 Control Sensitivity for Monitor	UINT
	D(m+35)	00-15	*_Ch1_ProportionalBandSta	Loop 1 Proportional Band for Monitor	UINT
	D(m+36)	00-15	*_Ch1_IntgTmSta	Loop 1 Integral Time for Monitor	UINT
	D(m+37)	00-15	*_Ch1_DerivativeTmSta	Loop1 Derivative Time for Monitor	UINT
	D(m+38)	00-15	*_Ch1_MV	Loop 1 Manipulated Variable Monitor	INT
	D(m+40)	00-15	*_Ch2_AL1LvlSta	Loop 2 Alarm 1 SV for Monitor	INT
	D(m+41)	00-15	*_Ch2_AL2LvlSta	Loop 2 Alarm 2 SV for Monitor	INT
	D(m+42)	00-15	*_Ch2_AllnOfsSta	Loop 2 Input Compensation Value for Monitor	INT
	D(m+43)	00-15	*_Ch2_CtlPrdSta	Loop 2 Control Period for Monitor	UINT
	D(m+44)	00-15	*_Ch2_CtlHysrsSta	Loop 2 Control Sensitivity for Monitor	UINT
	D(m+45)	00-15	*_Ch2_ProportionalBandSta	Loop 2 Proportional Band for Monitor	UINT
	D(m+46)	00-15	*_Ch2_IntgTmSta	Loop 2 Integral Time for Monitor	UINT
	D(m+47)	00-15	*_Ch2_DerivativeTmSta	Loop 2 Derivative Time for Monitor	UINT
	D(m+48)	00-15	*_Ch2_MV	Loop 2 Manipulated Variable Monitor	INT

A-4 Sample Programming

Process Value (PV) Import

● Outline

Store process value (PV) data of each loop (*Ch#_PV*) in the user-defined variable (*Temperature#*) which is the data storage destination.

Each input value is read when the Sensor Error Flag of each loop is OFF.

In this example, the device name "J01" is used when this Unit is registered in Unit Configuration.

● Defined-variable

User-defined variable

Name	Data type	Factory setting	Allocated address (AT)	Comments
Temperature1	BOOL	False	---	Loop 1 PV Data Storage Destination
Temperature2	BOOL	False	---	Loop 2 PV Data Storage Destination

Device variable for CJ-series Unit

Name	Data type	Factory setting	Allocated address (AT)	Comments
J01_Ch1_PV	INT	0	IOBus://rack#0/slot#0/Ch1_PV	Loop 1 Process Value
J01_Ch2_PV	INT	0	IOBus://rack#0/slot#0/Ch2_PV	Loop 2 Process Value
J01_Ch1_SensErr	BOOL	---	IOBus://rack#0/slot#0/Ch1_StaWd/Ch1_SensErr	Loop 1 Sensor Error Flag
J01_Ch2_SensErr	BOOL	---	IOBus://rack#0/slot#0/Ch2_StaWd/Ch2_SensErr	Loop 2 Sensor Error Flag

● Programming Example

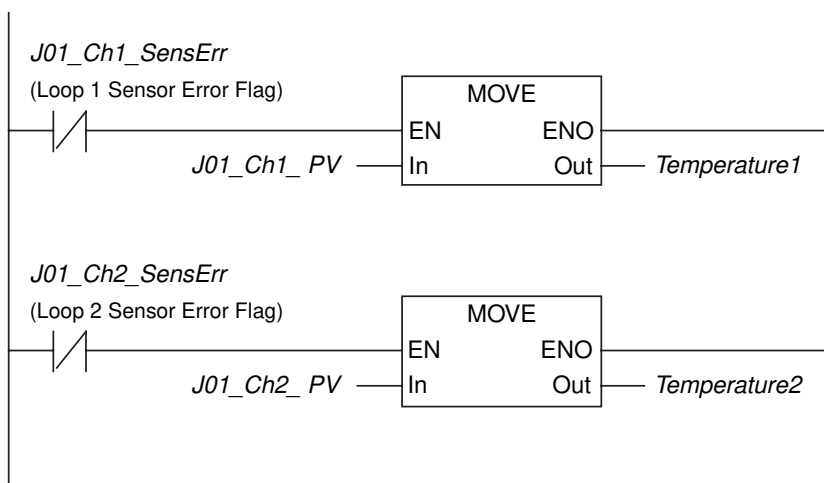

AT Execution and PID Constants Calculation

● Outline

The program from AT execution of loop 1 to PID constants calculation is shown below.

In this example, the device name "J01" is used when this Unit is registered in Unit Configuration.

● Defined-variable

User-defined variable

Name	Data type	Factory setting	Allocated address (AT)	Comments
ATrun	BOOL	False	---	AT Start Signal

Device variable for CJ-series Unit

Name	Data type	Factory setting	Allocated address (AT)	Comments
J01_Ch1_ATFlg	BOOL	False	IOBus://rack#0/slot#0/Ch1_StaWd/Ch1_ATFlg	Loop 1 AT Flag
J01_Ch1_PIDCalcFlg	BOOL	False	IOBus://rack#0/slot#0/Ch1_StaWd/Ch1_PIDCalcFlg	Loop 1 PID Constants Calculated Flag
J01_Ch1_SaveFlg	BOOL	False	IOBus://rack#0/slot#0/Ch1_StaWd/Ch1_SaveFlg	Loop 1 Save Completed Flag
J01_Ch1_ProportionalBandSta	UINT	0	IOBus://rack#0/slot#0/Ch1_ProportionalBandSta	Loop 1 Proportional Band for Monitor
J01_Ch1_ProportionalBandCfg	UINT	0	IOBus://rack#0/slot#0/Ch1_ProportionalBandCfg	Loop 1 Proportional Band
J01_Ch1_IntgTmSta	UINT	0	IOBus://rack#0/slot#0/Ch1_IntgTmSta	Loop 1 Integral Time for Monitor
J01_Ch1_IntgTmCfg	UINT	0	IOBus://rack#0/slot#0/Ch1_IntgTmCfg	Loop 1 Integral Time
J01_Ch1_DerivativeTmSta	UINT	0	IOBus://rack#0/slot#0/Ch1_DerivativeTmSta	Loop 1 Derivative Time for Monitor
J01_Ch1_DerivativeTmCfg	UINT	0	IOBus://rack#0/slot#0/Ch1_DerivativeTmCfg	Loop 1 Derivative Time
J01_Ch1_StartATCmd	BOOL	False	IOBus://rack#0/slot#0/Ch1_StartATCmd	Loop 1 Start AT Bit
J01_Ch1_ChgPIDCmd	BOOL	False	IOBus://rack#0/slot#0/Ch1_ChgPIDCmd	Loop 1 change PID Constants Bit
J01_Ch1_SaveCmd	BOOL	False	IOBus://rack#0/slot#0/Ch1_SaveCmd	Loop 1 Save Settings Bit

● Programming Example

Start AT Bit

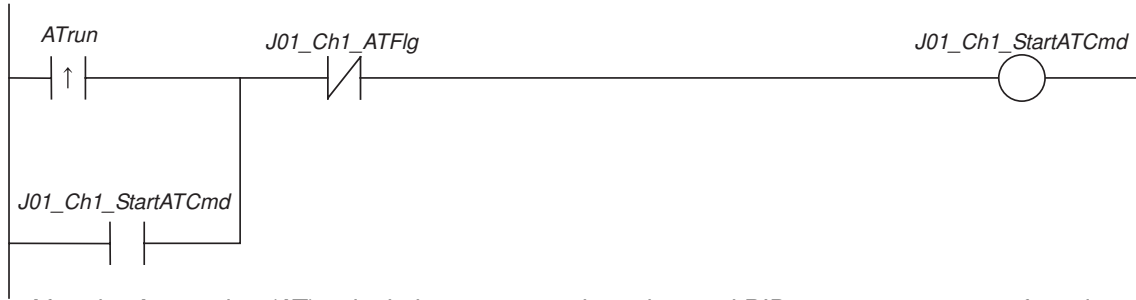

After the Autotuning (AT) calculations are complete, the read PID constants are transferred to the setting PID constants, updated, and saved to the non-volatile memory.

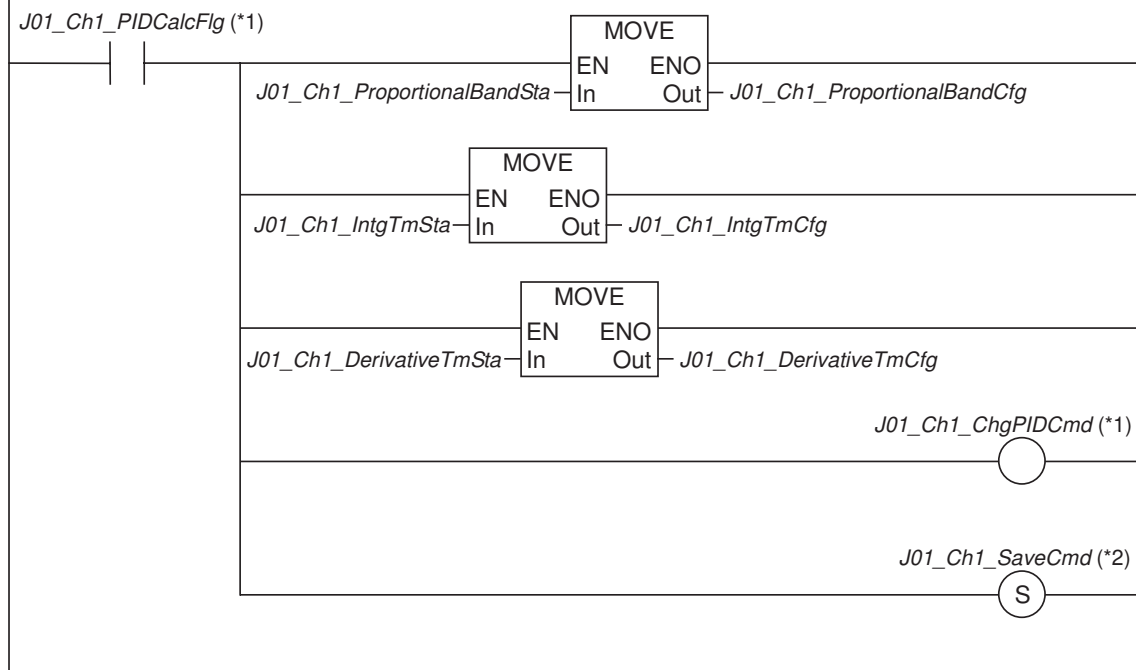

After saving to the non-volatile memory is complete, the save instruction is switched OFF.



*1 Change of Change PID Constants Bit (*J01_Ch1_ChgPIDCmd*) from OFF to ON changes the PID Constants Calculated Flag (*J01_Ch1_PIDCalcFlg*) from ON to OFF.

*2 With pin 8 of the DIP switch set to ON (transfer settings within non-volatile memory), be sure to write to the non-volatile memory of the Temperature Control Unit (change the Save Settings Bit from OFF to ON).

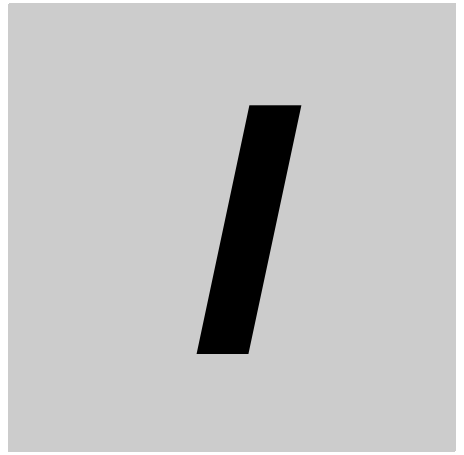

Index



Index

-
- A**
-
- (AT) autotuning 1-5, 3-11
 - Alarm 5-2
 - Alarm hysteresis 3-16
 - Alarm mode 3-15
 - Alarm output function 3-15
 - Alarm SVs 3-16
 - Assumed cause 5-17
 - AT (autotuning) 1-5, 3-11
 - AT execution A-11
 - Autotuning execution A-11
- C**
-
- °C/°F 2-13
 - Cold junction sensor error 5-8, 5-19
 - Connector 2-11
 - Control method 3-7
 - Control operation 1-5, 3-6
 - Control output 2-2
 - Control period 3-8
 - Control sensitivity 3-10
 - Controller errors 5-16
 - CPU unit error 5-2
 - CPU unit monitor error 5-8
 - CPU unit WDT error 5-9
 - CT (current transformer) 2-4, 3-19
 - CT overflow 5-7, 5-20
 - Current transformer (CT) 2-4, 3-19
 - Current transformer (CT) ratings 2-4
- D**
-
- Data storage/display format 2-14
 - Decimal point 2-29
 - Derivative time 3-7, 3-14
 - Device variables for CJ-series unit 2-21
 - Dielectric strength 2-2
 - DIP switch setting functions 2-13
 - Disabled loop 4-3
 - DM setting error (initialization data) 5-8
 - Duplicate unit number 5-9
- E**
-
- ERC indicator 2-11, 5-2
 - ERH indicator 2-11, 5-2
 - Error processing flowchart 5-3
 - Event code 5-17
 - Event name 5-17
 - Events 5-16
- F**
-
- Forward 3-6
- H**
-
- Hardware check error 5-8
 - HB (heater burnout alarm) 2-4
 - HB alarm errors 5-15
 - Heater burnout 1-5
 - Heater burnout (HB) 3-19
 - Heater burnout alarm 2-4, 5-7, 5-21
 - Heater burnout current 3-19, 3-20, 5-15
 - Heater burnout detection 3-19
 - Hunting 5-14
- I**
-
- I/O bus check error 5-9
 - I/O map 2-22
 - I/O port 2-22
 - I/O setting check error 5-9
 - I/O wiring examples 2-18
 - Indication accuracy 2-3
 - Initialization data 2-21, 2-30
 - Input compensation function 1-5
 - Input function block diagram 2-5
 - Input specifications 2-5
 - Input type settings 3-2
 - Input type switch 2-11, 2-15, 3-2
 - Insulation resistance 2-2
 - Integral time 3-7, 3-13
 - Internal alarm 1-6
 - Internal current consumption 2-2
- L**
-
- Limit-cycle method 1-5
- M**
-
- Measured temperature higher than
control temperature 5-13
 - Memory used for CJ-series unit A-4
 - Mounting the unit 1-8
- N**
-
- Non-volatile memory 1-6, 2-23
- O**
-
- ON/OFF control 1-4, 3-7, 3-10
 - Operating parameter 2-21, 2-32

Operation data	2-21, 2-24
Output circuits	2-17
Output errors	5-14
Output indicators	2-11
Overshooting	5-13

P

PID constant	3-11, 3-13
PID constants bit	3-11
PID constants calculated flag	3-11
PID control	1-4, 3-7
PID control with two degrees of freedom	1-4, 3-7
Pin 1 of the DIP switch (operation in PROGRAM mode)	2-13
Pin 2 of the DIP switch (°C/°F)	2-5, 2-13, 3-4
Pin 3 of the DIP switch	2-14, 3-5
Pin 4 of the DIP switch (control operation for loop 1)	2-14, 3-6
Pin 5 of the DIP switch (control operation for loop 2)	2-14, 3-6
Pin 6 of the DIP switch (control method)	2-14, 3-7
Pin 7 of the DIP switch (initialize non-volatile memory set values)	2-14
Pin 8 of the DIP switch (transfer non-volatile memory set values)	2-14, 2-23
Platinum resistance thermometer input setting ranges .	2-6
Process value (PV) Import	A-10
Proportional band	3-7, 3-13
PV (process value)	1-5

R

RAM	2-23
Restart	2-22
Reverse	3-6
RUN indicator	2-11, 5-2

S

(SP) set point	1-5, 3-9
Sampling period	2-3
Sensor error	5-7, 5-20
Set point	1-5, 3-9
Setting error	5-7, 5-19
Setting error numbers	2-29, 5-7
Simple method to check the temperature sensor inputs	5-12
Special I/O unit area	A-4
Special I/O unit DM area	A-4
Standby sequence	3-16
Status indicators	2-11
Stop bit	3-21
Sysmac Studio	2-7
System-defined variable	2-21

T

Temperature control errors	5-12
----------------------------------	------

Temperature control method	2-2
Temperature control unit error	5-2
Temperature units	3-4
Thermocouple input setting ranges	2-5

U

Undershooting	5-13
Unit configuration	2-7
Unit number switches	2-12, A-4
Unit restart	2-22

W

Warmup time	2-3
-------------------	-----

OMRON Corporation Industrial Automation Company

Tokyo, JAPAN

Contact: www.ia.omron.com

Regional Headquarters

OMRON EUROPE B.V.

Wegalaan 67-69-2132 JD Hoofddorp
The Netherlands

Tel: (31)2356-81-300/Fax: (31)2356-81-388

OMRON ELECTRONICS LLC

One Commerce Drive Schaumburg,
IL 60173-5302 U.S.A.

Tel: (1) 847-843-7900/Fax: (1) 847-843-7787

OMRON ASIA PACIFIC PTE. LTD.

No. 438A Alexandra Road # 05-05/08 (Lobby 2),
Alexandra Technopark,
Singapore 119967

Tel: (65) 6835-3011/Fax: (65) 6835-2711

OMRON (CHINA) CO., LTD.

Room 2211, Bank of China Tower,
200 Yin Cheng Zhong Road,
PuDong New Area, Shanghai, 200120, China

Tel: (86) 21-5037-2222/Fax: (86) 21-5037-2200

Authorized Distributor:

© OMRON Corporation 2011 All Rights Reserved.
In the interest of product improvement,
specifications are subject to change without notice.

Cat. No. W491-E1-03

0812