

**G3ZA**

# **Multi-channel Power Controller**

# **USER'S MANUAL**

**OMRON**

# **G3ZA**

# **Multi-channel Power Controller**

## **User's Manual**

*Produced February 2007*



# ***Preface***

OMRON products are manufactured for use according to proper procedures by a qualified operator and only for the purposes described in this manual.

This manual describes the functions, performance, and application methods needed for optimum use of the G3ZA.

Please observe the following items when using the G3ZA.

- This product is designed for use by qualified personnel with a knowledge of electrical systems.
- Read this manual carefully and make sure you understand it well to ensure that you are using the G3ZA correctly.
- Keep this manual in a safe location so that it is available for reference when required.

© OMRON, 2004

All rights reserved. No part of this publication may be reproduced, stored in a retrieval system, or transmitted, in any form, or by any means, mechanical, electronic, photocopying, recording, or otherwise, without the prior written permission of OMRON.

No patent liability is assumed with respect to the use of the information contained herein. Moreover, because OMRON is constantly striving to improve its high-quality products, the information contained in this manual is subject to change without notice. Every precaution has been taken in the preparation of this manual. Nevertheless, OMRON assumes no responsibility for errors or omissions. Neither is any liability assumed for damages resulting from the use of the information contained in this publication.

## Read and Understand this Manual

Please read and understand this manual before using the product. Please consult your OMRON representative if you have any questions or comments.

## Warranty and Limitations of Liability

### WARRANTY

OMRON's exclusive warranty is that the products are free from defects in materials and workmanship for a period of one year (or other period if specified) from date of sale by OMRON. OMRON MAKES NO WARRANTY OR REPRESENTATION, EXPRESS OR IMPLIED, REGARDING NON-INFRINGEMENT, MERCHANTABILITY, OR FITNESS FOR PARTICULAR PURPOSE OF THE PRODUCTS. ANY BUYER OR USER ACKNOWLEDGES THAT THE BUYER OR USER ALONE HAS DETERMINED THAT THE PRODUCTS WILL SUITABLY MEET THE REQUIREMENTS OF THEIR INTENDED USE. OMRON DISCLAIMS ALL OTHER WARRANTIES, EXPRESS OR IMPLIED.

### LIMITATIONS OF LIABILITY

OMRON SHALL NOT BE RESPONSIBLE FOR SPECIAL, INDIRECT, OR CONSEQUENTIAL DAMAGES, LOSS OF PROFITS OR COMMERCIAL LOSS IN ANY WAY CONNECTED WITH THE PRODUCTS, WHETHER SUCH CLAIM IS BASED ON CONTRACT, WARRANTY, NEGLIGENCE, OR STRICT LIABILITY.

In no event shall the responsibility of OMRON for any act exceed the individual price of the product on which liability is asserted.

IN NO EVENT SHALL OMRON BE RESPONSIBLE FOR WARRANTY, REPAIR, OR OTHER CLAIMS REGARDING THE PRODUCTS UNLESS OMRON'S ANALYSIS CONFIRMS THAT THE PRODUCTS WERE PROPERLY HANDLED, STORED, INSTALLED, AND MAINTAINED AND NOT SUBJECT TO CONTAMINATION, ABUSE, MISUSE, OR INAPPROPRIATE MODIFICATION OR REPAIR.

## Application Considerations

### SUITABILITY FOR USE

OMRON shall not be responsible for conformity with any standards, codes, or regulations that apply to the combination of products in the customer's application or use of the products.

At the customer's request, OMRON will provide applicable third party certification documents identifying ratings and limitations of use that apply to the products. This information by itself is not sufficient for a complete determination of the suitability of the products in combination with the end product, machine, system, or other application or use.

The following are some examples of applications for which particular attention must be given. This is not intended to be an exhaustive list of all possible uses of the products, nor is it intended to imply that the uses listed may be suitable for the products.

- Outdoor use, uses involving potential chemical contamination or electrical interference, or conditions or uses not described in this manual.
- Nuclear energy control systems, combustion systems, railroad systems, aviation systems, medical equipment, amusement machines, vehicles, safety equipment, and installations subject to separate industry or government regulations.
- Systems, machines, and equipment that could present a risk to life or property.

Please know and observe all prohibitions of use applicable to the products.

NEVER USE THE PRODUCTS FOR AN APPLICATION INVOLVING SERIOUS RISK TO LIFE OR PROPERTY WITHOUT ENSURING THAT THE SYSTEM AS A WHOLE HAS BEEN DESIGNED TO ADDRESS THE RISKS, AND THAT THE OMRON PRODUCTS ARE PROPERLY RATED AND INSTALLED FOR THE INTENDED USE WITHIN THE OVERALL EQUIPMENT OR SYSTEM.

### PROGRAMMABLE PRODUCTS

OMRON shall not be responsible for the user's programming of a programmable product, or any consequence thereof.

## Disclaimers

### **CHANGE IN SPECIFICATIONS**

Product specifications and accessories may be changed at any time based on improvements and other reasons.

It is our practice to change model numbers when published ratings or features are changed, or when significant construction changes are made. However, some specifications of the products may be changed without any notice. When in doubt, special model numbers may be assigned to fix or establish key specifications for your application on your request. Please consult with your OMRON representative at any time to confirm actual specifications of purchased products.

### **DIMENSIONS AND WEIGHTS**

Dimensions and weights are nominal and are not to be used for manufacturing purposes, even when tolerances are shown.

### **PERFORMANCE DATA**

Performance data given in this manual is provided as a guide for the user in determining suitability and does not constitute a warranty. It may represent the result of OMRON's test conditions, and the users must correlate it to actual application requirements. Actual performance is subject to the OMRON Warranty and Limitations of Liability.

### **ERRORS AND OMISSIONS**

The information in this document has been carefully checked and is believed to be accurate; however, no responsibility is assumed for clerical, typographical, or proofreading errors, or omissions.

# Safety Precautions

## ■ Definition of Precautionary Information

The following notation is used in this manual to provide precautions required to ensure safe usage of the product.





The safety precautions that are provided are extremely important to safety. Always read and heed the information provided in all safety precautions.

The following notation is used.





 <b>WARNING</b>	<p>Indicates a potentially hazardous situation which, if not avoided, will result in minor or moderate injury, or may result in serious injury or death. Additionally there may be significant property damage.</p>
--	---

 <b>CAUTION</b>	<p>Indicates a potentially hazardous situation which, if not avoided, may result in minor or moderate injury or in property damage.</p>
--	---

## ■ Symbols

Symbol		Meaning
Caution		<p><b>General Caution</b> Indicates non-specific general cautions, warnings, and dangers.</p>
		<p><b>Electrical Shock Caution</b> Indicates possibility of electric shock under specific conditions.</p>
Prohibition		<p><b>General Prohibition</b> Indicates non-specific general prohibitions.</p>
Mandatory Caution		<p><b>General Caution</b> Indicates non-specific general cautions, warnings, and dangers.</p>

## ■ Precautions

 <b>WARNING</b>	
Do not touch the terminals and the wires while power is being supplied. Doing so may possibly result in electric shock. Make sure that the terminal cover is installed before using the product.	
 <b>CAUTION</b>	
Do not allow pieces of metal, wire clippings, or fine metallic chips or filings from installation to enter the product. Doing so may occasionally result in electric shock, fire, or malfunction.	
Do not use the product in locations of flammable or explosive gases. Doing so may occasionally result in minor or moderate explosion, causing minor or moderate injury, or property damage.	
Do not attempt to disassemble, repair, or modify the product. Doing so may occasionally result in minor or moderate injury due to electric shock.	
Perform correct setting of the product according to the application. Failure to do so may occasionally cause unexpected operation, resulting in minor or moderate injury, or damage to the equipment.	
Ensure safety in the event of product failure by taking safety measures, such as installing a separate monitoring system to provide alarms for preventing excessive temperature rise. Product failure may occasionally prevent control operation, resulting in damage to the connected facilities and equipment.	
Tighten the terminal screws securely using a tightening torque within the following ranges. Loose screws may occasionally cause fire, resulting in minor or moderate injury, or damage to the equipment. Terminal screws: 0.40 to 0.56 N·m	



## Precautions for Safe Use

- (1) Do not use the product in the following locations.
  - Locations subject to direct radiant heat from heating equipment
  - Locations where the product may come into contact with water or oil
  - Locations subject to direct sunlight
  - Locations where dust or corrosive gases (in particular, sulfuric or ammonia gas) are present
  - Locations subject to extreme temperature changes
  - Locations where icing or condensation may occur
  - Locations subject to excessive shocks or vibration
- (2) Use this product within the rated load and power supply.
- (3) Ensure that the rated voltage is achieved no longer than 2 s after turning the power ON.
- (4) Use/store within the rated temperature and humidity ranges. Provide forced-cooling if required.
- (5) Minimum mounting distance of G3ZA is 10 mm.  
When mounting the G3ZA near the SSRs, mount the G3ZA so as to not interfere with the heat dissipation of the SSR.
- (6) Use the specified size of insulated type crimp terminals (M3, width: 5.8 mm max.) for wiring and attach insulative sleeves. To connect bare wires, use AWG22 (cross section: 0.326 mm<sup>2</sup>) to AWG14 (cross section: 2.081 mm<sup>2</sup>) to wire the power supply terminals and AWG22 (cross section: 0.326 mm<sup>2</sup>) to AWG16 (cross section: 1.039 mm<sup>2</sup>) for other terminals.
- (7) Be sure to confirm the correct terminal and polarity when wiring the terminal block and connectors.
- (8) Do not connect any conductors to unused terminals.
- (9) In order to prevent inductive noise, wire the lines connected to the product separately from power lines carrying high voltages or currents. Do not wire in parallel with or in the same cable as power lines. Other measures for reducing noise include running lines along separate ducts and using shield lines.
- (10) Attach a surge suppressor or noise filter to peripheral devices that generate noise (in particular, motors, transformers, solenoids, magnetic coils or other equipment that have an inductance component).  
Do not install the product near devices generating strong high-frequency fields or surges. When using a noise filter, check the voltage and current and install it as close to the product as possible.
- (11) For a safety disconnection of the power-line in the application the equipment shall be provided with disconnecting devices suitable for isolation (e.g. circuit breakers IEC60947-2, power switches IEC60947-3, and power plugs).

### **Precautions when Using Unit Version 1.0**

Unit version 1.0 is for use with single-phase loads only. Connect single-phase zero-cross SSRs. Do not connect three-phase SSRs, electromagnetic relays, or single-phase SSRs without the zero-cross function.

### **Precautions when Using Unit Version 2.0**

- When wiring the SSR, check the G3ZA's settings and select the correct SSR from the following supported SSRs.
  - SSR for single-phase heater with zero-cross function
  - SSR for single-phase heater without zero-cross function
  - SSR for three-phase heater

Do not connect an electromagnetic relay.

- When wiring the CT, check the G3ZA's settings and select the correct CT from the following supported CTs.
  - E54-CT1
  - E54-CT3
  - G3ZA-CT150L

**Note** For details on checking the G3ZA's unit version, refer to *Identifying an Upgraded Controller* on page xiii.

# Conventions Used in This Manual

## ■ Meanings of Abbreviations

The following abbreviations are used in parameter names, figures, and in text in this manual. These abbreviations mean the following:

Abbreviation	Term
ch	Channel
MV	Manipulated variable
EJ1	EJ1-series Temperature Controller (See note.)

**Note** The EJ1 Series is a series of OMRON Temperature Controllers. For details on the functions of these Temperature Controllers, refer to the *EJ1 Modular Temperature Controller User's Manual* (Cat. No. H142) or the *EJ1G Modular Temperature Controllers for Gradient Temperature Control User's Manual* (Cat. No. H143).

## ■ Functional Upgrades in G3ZA Version 2.0

Functions were added to control halogen heaters and three-phase heaters. Descriptions of these functional upgrades have been added to this manual and are indicated by the **V2** symbol.

### Identifying an Upgraded Controller

The Controller's version can be identified on the Unit's label or the box label. If there is no unit version number, the Controller's version is 1.0.

#### Box Label

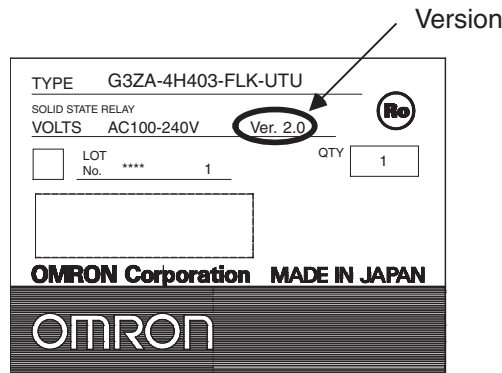

#### Power Controller Label

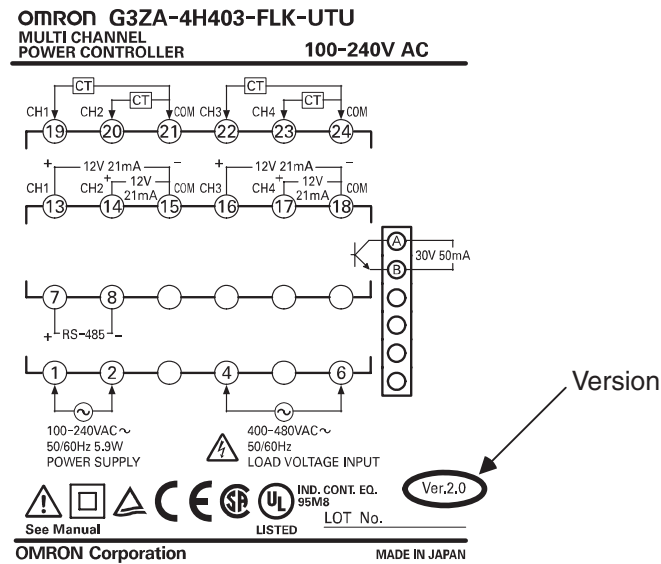



# TABLE OF CONTENTS

## SECTION 1

<b>Overview</b> .....	<b>1</b>
1-1 Features .....	2

## SECTION 2

<b>Preparations</b> .....	<b>7</b>
2-1 Installation .....	8
2-2 How To Use the Terminals .....	11

## SECTION 3

<b>Communications (CompoWay/F)</b> .....	<b>17</b>
3-1 Communications Settings .....	18
3-2 Frame Configuration .....	19
3-3 FINS-mini Text .....	21
3-4 Variable Area Write .....	23
3-5 Variable Area Read .....	24
3-6 Operation Command .....	25
3-7 Controller Attribute Read .....	26
3-8 Controller Status Read .....	27
3-9 Echo-back Test .....	28

## SECTION 4

<b>Functions</b> .....	<b>29</b>
4-1 Setup Procedure .....	30
4-2 Selecting the SSR (Control Method) 4 or 8-channel Models) .....	31
4-3 Selecting the CT (4-channel Models Only) .....	33
4-4 Allocating CTs (4-channel Models Only) .....	35
4-5 Detecting Heater Burnouts (4-channel Models Only) .....	36
4-6 Detecting Heater Overcurrent (4-channel Models Only) .....	43
4-7 Detecting SSR Short-Circuits (4-channel Models Only) .....	45
4-8 Detecting Communications Timeouts (4 and 8-channel Models) .....	48
4-9 Setting the Soft Increase and Soft Decrease Times (4 and 8-channel Models) .....	49
4-10 Changing the Manipulated Variable (4 and 8-channel Models) .....	50
4-11 Offsetting the Control Output's ON Timing (4 and 8-channel Models) .....	51
4-12 Turning OFF a Control Output (4 and 8-channel Models) .....	52
4-13 Setting the Abnormal Current Detection Delay (4 and 8-channel Models) .....	52
4-14 Setting Operation at Error (4 and 8-channel Models) .....	53
4-15 Monitoring the Effective Current .....	54

## SECTION 5

<b>Troubleshooting</b> .....	<b>57</b>
5-1 Errors .....	58
5-2 Handling Problems .....	59

<b>Appendix</b> .....	<b>61</b>
<b>Index</b> .....	<b>75</b>
<b>Revision History</b> .....	<b>77</b>

## ***About this Manual:***

This manual describes the installation and operation of the G3ZA Multi-channel Power Controller and includes the sections described below.

Please read this manual carefully and be sure you understand the information provided before attempting to install or operate the G3ZA. Be sure to read the precautions provided at the beginning of this manual.

The **Preface** provides precautions for using the G3ZA and information on using this manual.

**Section 1** introduces the G3ZA and its features.

**Section 2** describes preparations for using the G3ZA, including installation and wiring.

**Section 3** describes how to use the G3ZA Controller's communications functions, focusing on the CompoWay/F communications commands.

**Section 4** describes the functions of the G3ZA so that these functions can be used effectively according to the application.

**Section 5** provides information on problems that may occur during operation and corrective measures.

The **Appendix** provides G3ZA specifications, tables of settings, and other information.

 **WARNING** Failure to read and understand the information provided in this manual may result in personal injury or death, damage to the product, or product failure. Please read each section in its entirety and be sure you understand the information provided in the section and related sections before attempting any of the procedures or operations given.





# SECTION 1 Overview

This section introduces the G3ZA and its features.

1-1	Features <b>V2</b> .....	2
-----	--------------------------	---

## 1-1 Features

The G3ZA is a Multi-channel Power Controller with externally connected SSRs. It can receive manipulated variables from a PLC, EJ1 Temperature Controller, or other host via RS-485 communications and control heater power with high precision via the SSRs.

### SSR Drive Selection

**V2**

The control method used to drive the SSRs can be selected to enable using the G3ZA for a variety of applications. For example, to use a single-phase halogen heater, soft-start optimum cycle control can be selected to reduce inrush power when starting.

SSR	Control method	Application example
SSR for single-phase heater with zero-cross function	Optimum cycle control	Single-phase heaters
SSR for single-phase heater without zero-cross function	Soft-start optimum cycle control	Single-phase halogen heaters
SSR for three-phase heater with zero-cross function	Three-phase optimum cycle control	Three-phase heaters

Refer to *4-2 Selecting the SSR (Control Method) 4 or 8-channel Models* **V2** for details on selecting the SSR and the control method.

### Main Functions

#### Offset Control

- The timing of turning ON the control outputs for G3ZA channels can be offset to help prevent control outputs from being turned ON at the same time.

#### Manipulated Value Calculations

- The manipulated variable can be calculated for one channel and the calculated value can be output for another channel.

#### Effective Current Monitor

**V2**

- The effective current flowing to a heater can be monitored to one decimal place.

#### Error Detection (4-channel Controllers Only)

- The current flowing through the heater can be monitored to detect heater burnouts, heater overcurrents, and SSR short-circuits. (This function can be used for SSRs with ratings of up to 150 A.)

#### Number of Outputs Connected

- Between one and four outputs can be connected to 4-channel Controllers and between one and eight outputs can be connected to 8-channel Controllers.

#### Alarm Output

- An open-collector output terminal can be used to inform the host of errors without using communications.

#### Installation

- RS-485 communications can be used to set and operate the G3ZA, reducing the amount of wiring required between the G3ZA and host.
- Up to 31 Controllers can be connected to one communications line. With 4-channel Controllers, up to 124 channels can be controlled, and with 8-channel Controllers, up to 248 channels can be controlled.
- Up to 8 G3ZA Multi-channel Power Controllers can be connected to the communications port of an EJ1□-TC2/4. In addition, it is not necessary to create a communications program for communications between the EJ1 and G3ZA.

**Setting an Abnormal Current Detection Delay**



- An abnormal current detection delay can prevent noise from causing false detection by requiring a fixed number of consecutive error detections (heater burnout, heater overcurrent, or SSR short-circuit detections) before an error is actually detected.

**Available Models**

The following four models are available.

Model number	Number of channels	Error detection	Load power supply
G3ZA-4H203-FLK-UTU	4 channels	Supported	100 to 240 V
G3ZA-4H403-FLK-UTU			400 to 480 V
G3ZA-8A203-FLK-UTU	8 channels	Not supported	100 to 240 V
G3ZA-8A403-FLK-UTU			400 to 480 V

**Connections**

**Single-phase SSRs**

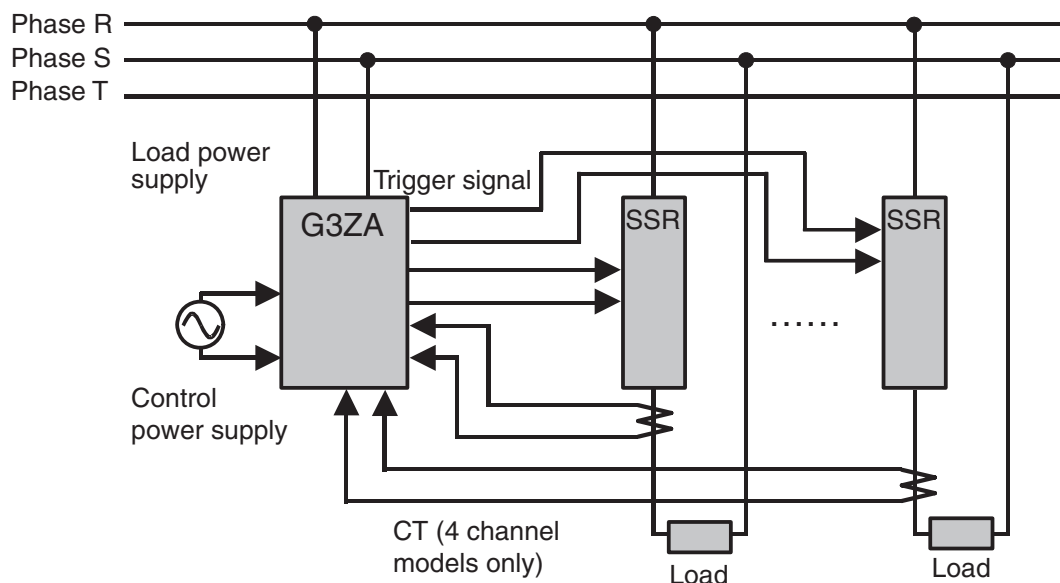

**Note** Connect a power supply with the same phase as the SSRs to the load power supply input terminals on the G3ZA.

Three-phase SSRs **V2**

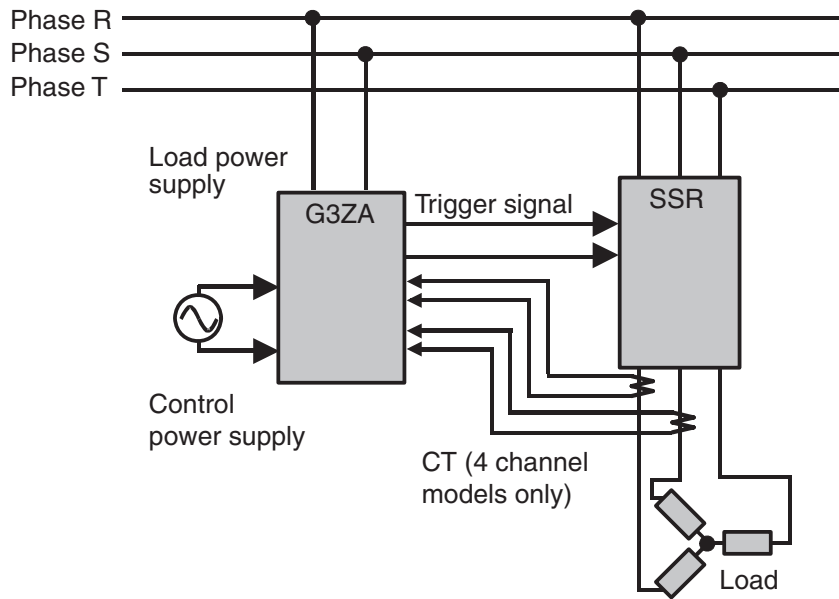

**Note** Out of the three phases, connect any one phase to the G3ZA Controller's load power supply input terminals.

**Component Names and Functions**

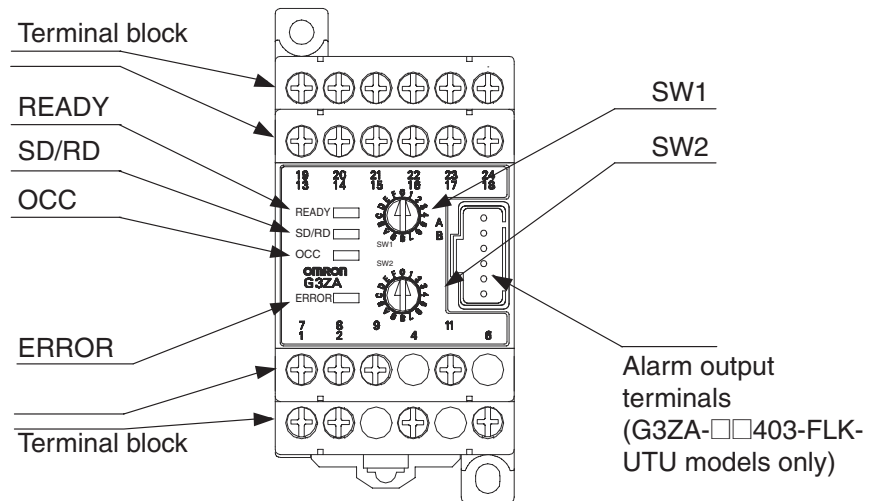

**Operation Indicators**

Operation indicator	Meaning
READY	Lit while power is being supplied.
SD/RD	Lit while communicating with the host.
OCC	Lit while a control output is ON.
ERROR	Lights or flashes when an error is detected.

**Switches SW1 and SW2**

SW1 and SW2 are used to set the communications unit number and baud rate. Refer to 3-1 Communications Settings on page 18 for details.

**Alarm Output**

Outputs an alarm to the output terminal (open collector).

For details, refer to *Alarm Output with 200 V Rating (Terminals 9 and 11)* or *Alarm Output with 400 V Rating (Connector Pins A and B)* on page 13.

**Terminal Block**

I/O signals connect to the terminal block. For details, refer to *2-2 How To Use the Terminals* on page 11.



# SECTION 2

## Preparations

This section describes preparations for using the G3ZA, including installation and wiring.

2-1	Installation . . . . .	8
2-2	How To Use the Terminals . . . . .	11



## 2-1 Installation

### Dimensions (Unit: mm)

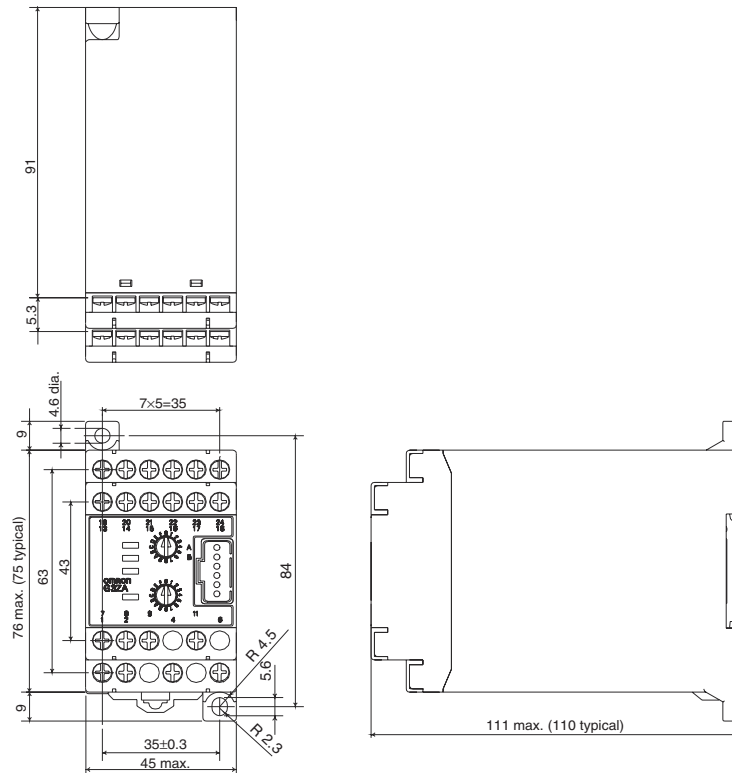

### Mounting to DIN Rail

#### DIN Rail Products

When installing a DIN Rail inside a control panel, secure the DIN Rail with screws in at least three locations.

- DIN Rail: PFP-50N (50 cm) or PFP-100N (100 cm)

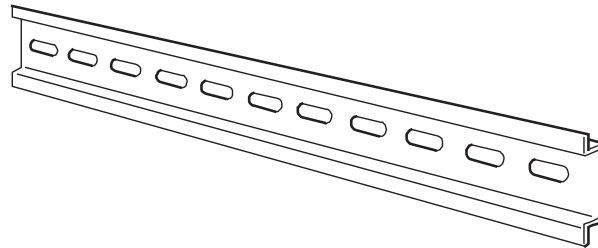

- End Plates: PFP-M

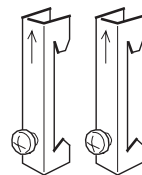

**Mounting the G3ZA**

Mount the G3ZA as shown in the diagram. First, pull down the DIN Track mounting hook (1) and hook the top of the G3ZA on the DIN Track (2). Then press the G3ZA onto the DIN Track far enough so that it can be locked in place (3) and push the DIN Track mounting hook up to lock the G3ZA in place (4).

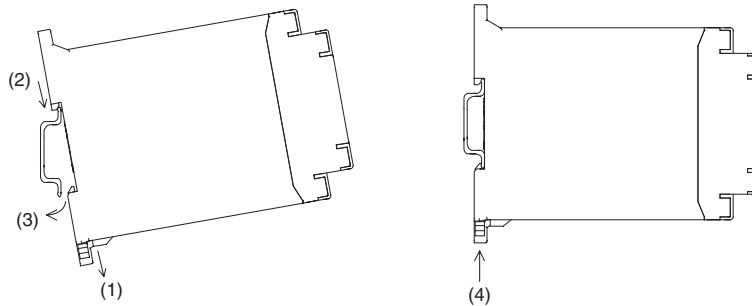

**Removing the G3ZA**

Use a flat-blade screwdriver to pull down the DIN Track mounting hook (1) and then pull out on the bottom of the G3ZA (2).

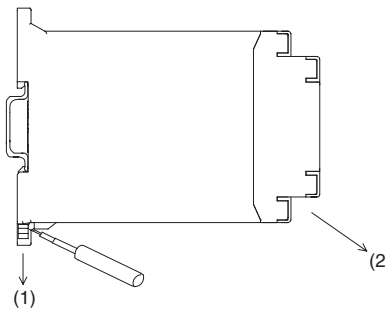

**Mounting End Plates**

Be sure to mount an End Plate on each side of the G3ZA so that it does not slide on the DIN Track.

To mount an End Plate, hook the bottom of the End Plate on the bottom of the DIN Track (1), place the top of the End Plate on the DIN Track (2), and then pull down on the End Plate. Tighten the screw on the End Plate to secure it.

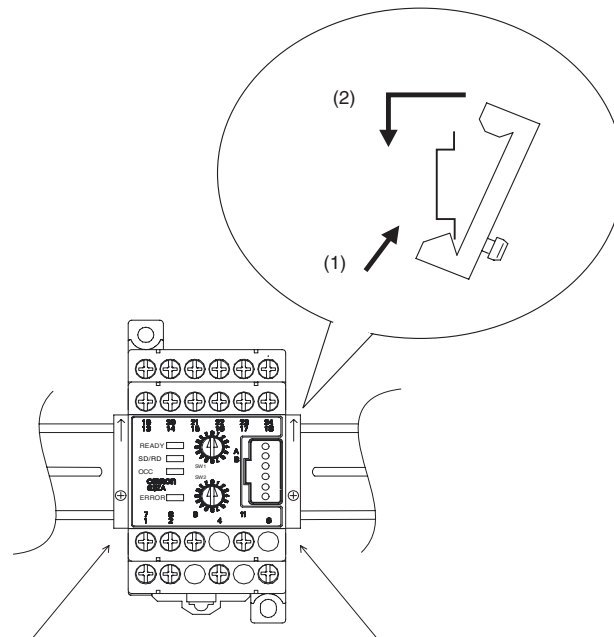

**Note** Always mount one End Plate on each side of the G3ZA.

**Mounting the G3ZA with Screws**

**Mounting Hole  
Dimensions (Unit: mm)**

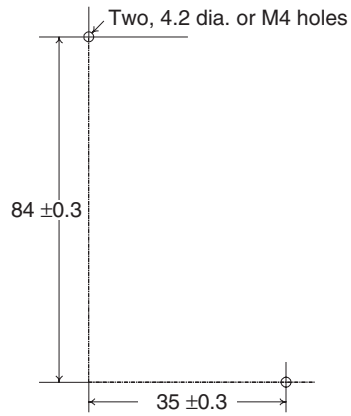

## 2-2 How To Use the Terminals

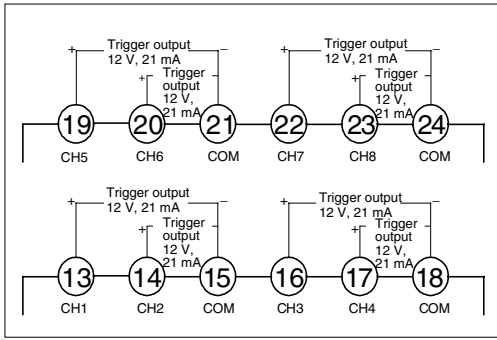

G3ZA-8A□03-FLK-UTU

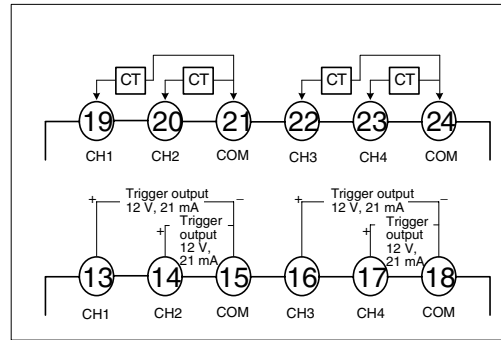

G3ZA-4H□03-FLK-UTU

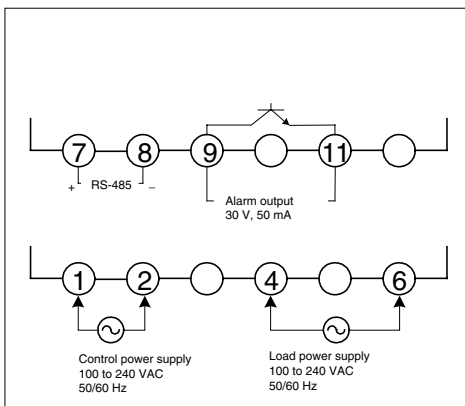
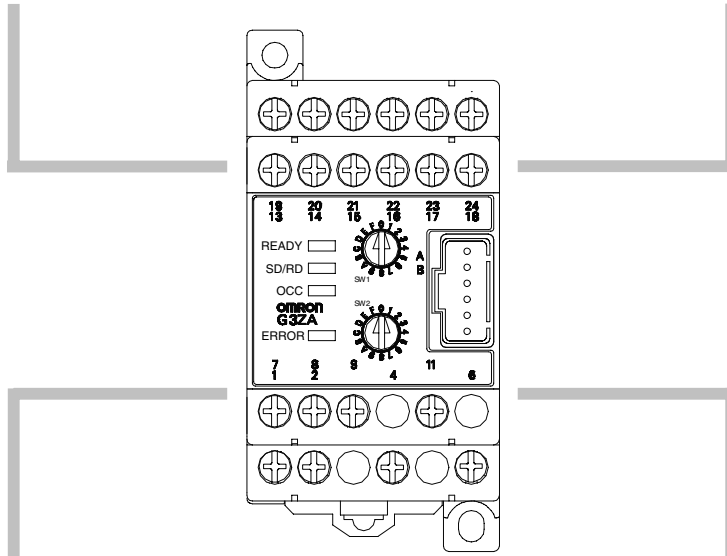

G3ZA-□□203-FLK-UTU

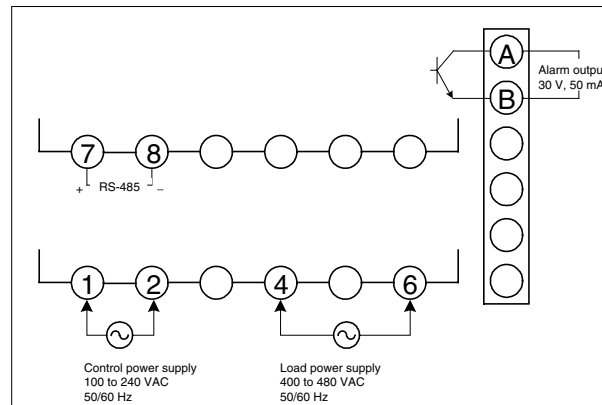

G3ZA-□□403-FLK-UTU

Preparations

### Wiring Diagrams

#### Wiring Precautions

- To avoid the effects of noise, wire signal lines separately from power lines.
- Use cables with wires that have sufficient capacity.
- Attach solderless crimp terminals on wires that connect to the terminal block.
- Use one of the following M3 solderless terminals for wiring.

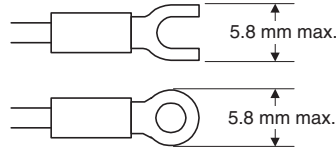

Use wires that are rated to withstand 70 °C minimum.

In the wiring diagrams, the area within the lines indicating terminals numbers is inside the G3ZA and the area outside the lines are outside the G3ZA.

#### Control Power Supply (Terminals 1 and 2)

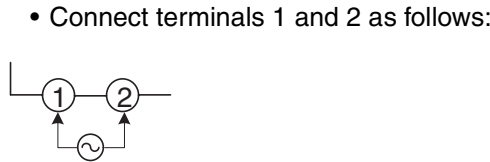
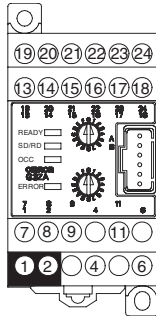

- The input power is 100 to 240 VAC.

#### Load Power Supply Input (Terminals 4 and 6)

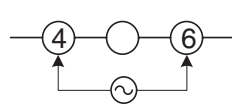
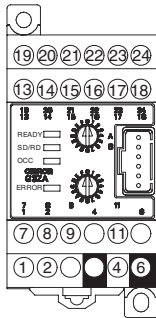

The voltage of the load power supply that can be connected depends on the model of the Controller.

- 100 to 240 VAC or 400 to 480 VAC
- The G3ZA detects the zero cross point of the load power supply.
- Use a load power supply with the same phase as the G3ZA Controller's input power supply.
- The system will not be controlled correctly if the control power supply is phase-controlled or has a different frequency from the input power supply.

#### RS-485 Communications (Terminals 7 and 8)

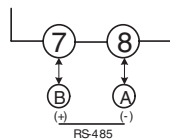
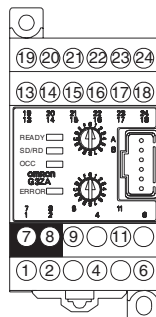

- To communicate with a host system, connect the communications line to terminals 7 and 8 as follows:
- The connection type can be 1: 1 or 1: N. For 1: N connections, up to 32 Units can be connected, including the host.
- The maximum cable length is 500 m total.

**Cable Diagram (Reference)**

- Use shielded twisted-pair cables (AWG16 to AWG22).

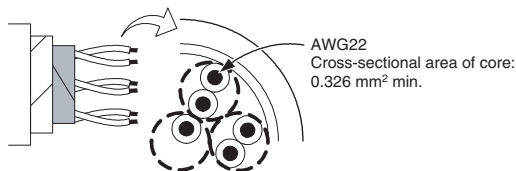

- Terminators must be connected at both ends of the transmission line, including the PLC. Use terminators with a combined resistance of at least 54 Ω.
- Alarms are output on terminals 9 and 11.

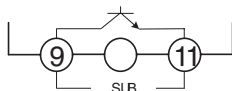

- The alarm output specifications are as follows:  
Maximum load voltage: 30 VDC  
Maximum load current: 50 mA

**Alarm Output with 200 V Rating (Terminals 9 and 11)**

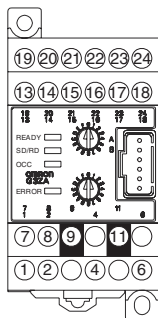

**Alarm Output with 400 V Rating (Connector Pins A and B)**

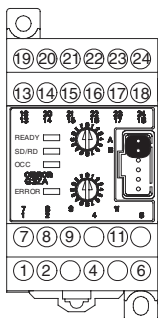

- Alarms are output on pins A and B of the connector.
- The alarm output specifications are as follows:

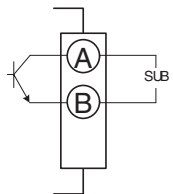

Maximum load voltage: 30 VDC  
Maximum load current: 50 mA

- The C-Grid SL connector for Molex Incorporated can be used for the connector.

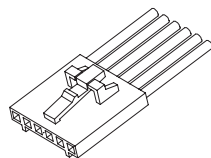

Model number: 51030-0630  
C-Grid SL Housing

**Trigger Outputs (Terminals 13 to 18)**

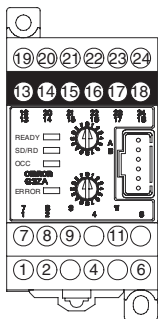

- The trigger outputs for channels 1 to 4 are output on terminals 13 to 18.

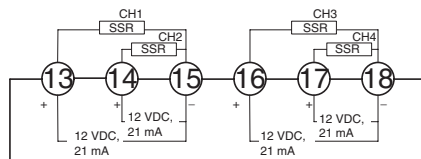

Output voltage: 12 VDC ±15%  
PNP  
Maximum load current: 21 mA  
Short-circuit protection circuit provided.

**Controllers without a Current Transformer Input Circuit (G3ZA-8A□03-FLK-UTU)**

- The trigger outputs for channels 5 to 8 are output on terminals 19 to 24.

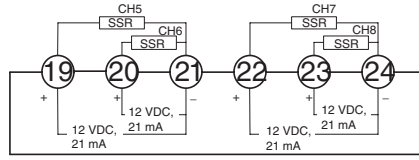

**Controllers with Built-in Current Transformer Circuits (G3ZA-4H□03-FLK-UTU)**

- Connect terminals 19 to 24 to the current transformers (no polarity) to detect heater burnouts, heater overcurrents, and SSR short-circuits.

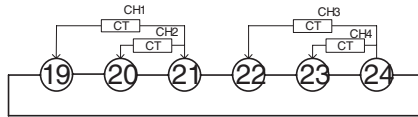

There are four current transformer inputs that can be used. Use the E54-CT1, the E54-CT3, or the G3ZA-CT150L from OMRON as the current transformer.

**Current Transformer Inputs (4-channel Models Only, Terminals 19 to 24)**

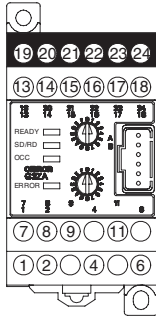

**Connection Examples**

**Example Connection with the PLC**

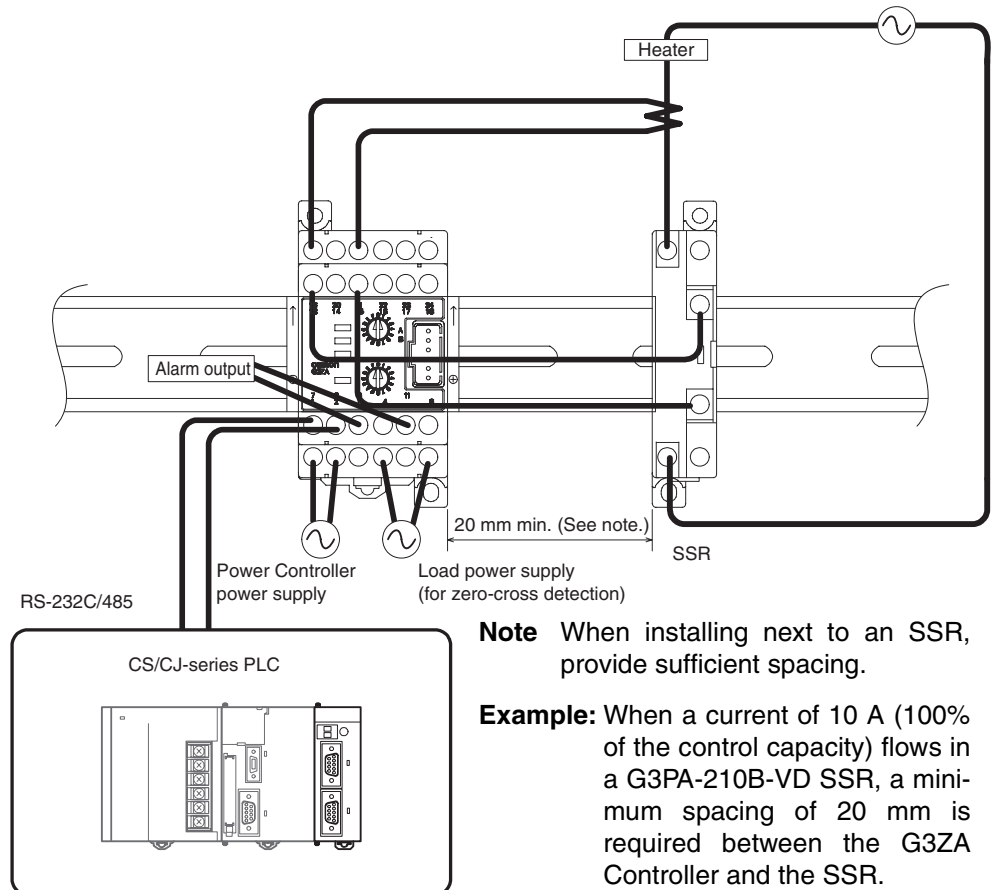

**Note** When installing next to an SSR, provide sufficient spacing.

**Example:** When a current of 10 A (100% of the control capacity) flows in a G3PA-210B-VD SSR, a minimum spacing of 20 mm is required between the G3ZA Controller and the SSR.

Example Connection with the EJ1

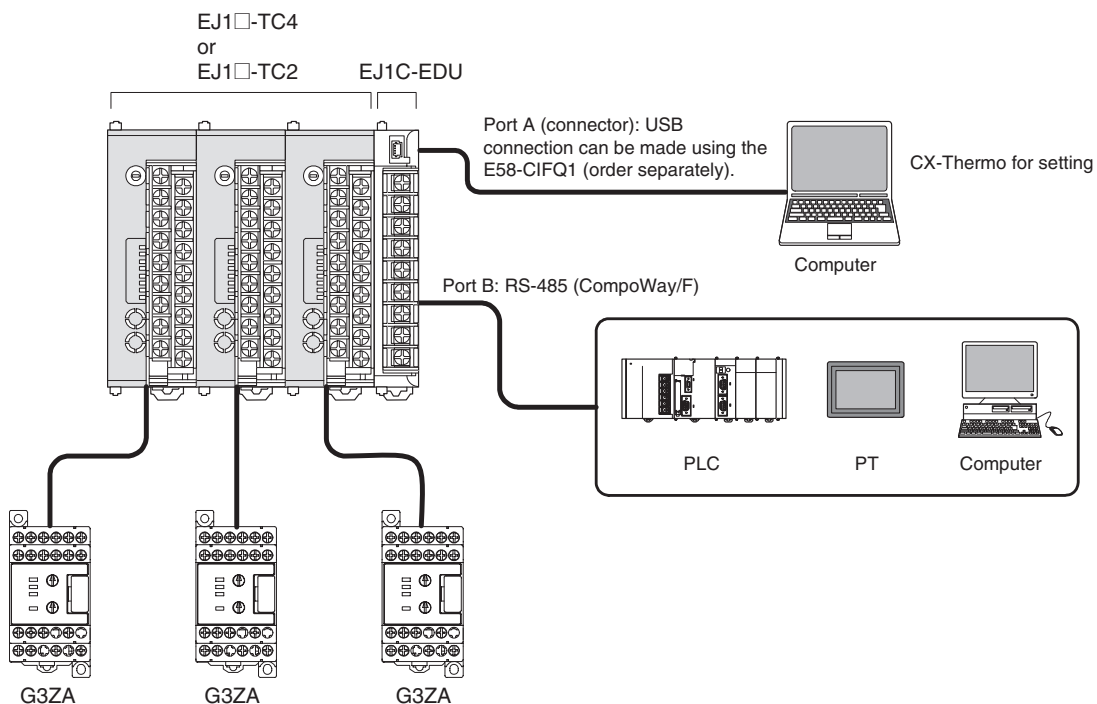

Preparations

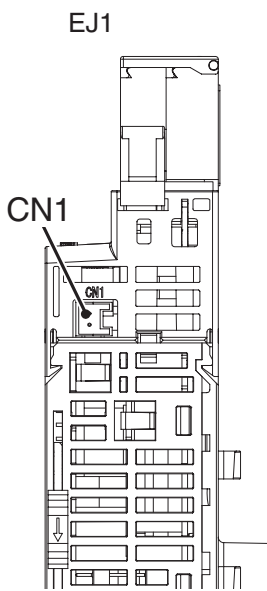

Connect the G3ZA Connecting Cable to the CN1 connector on the bottom of the TC Unit.

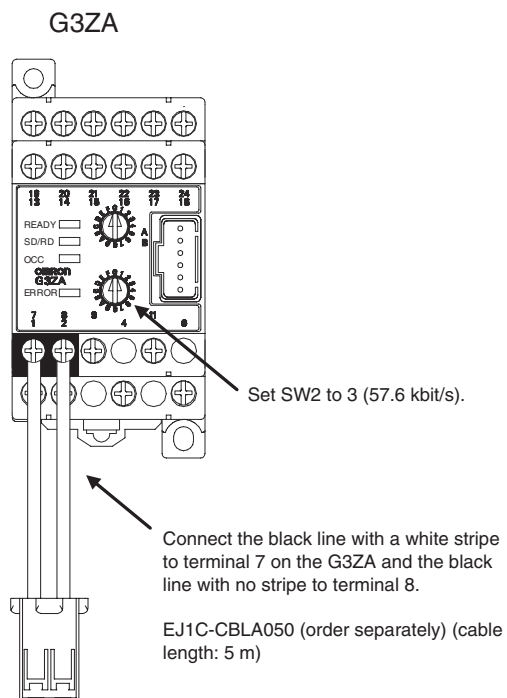





# SECTION 3

## Communications (CompoWay/F)

This section describes application information, including settings, communications, and controlling operation.

3-1	Communications Settings . . . . .	18
3-2	Frame Configuration . . . . .	19
3-3	FINS-mini Text . . . . .	21
3-4	Variable Area Write . . . . .	23
3-5	Variable Area Read . . . . .	24
3-6	Operation Command . . . . .	25
3-7	Controller Attribute Read . . . . .	26
3-8	Controller Status Read . . . . .	27
3-9	Echo-back Test . . . . .	28

### 3-1 Communications Settings

G3ZA settings and operation are performed using RS-485 communications. The communications functions use the program created in the host computer. Descriptions of communications in this manual are therefore written from the viewpoint of the host computer. For example, references to reading and writing mean reading data from the G3ZA to the host computer and writing data from the host computer to the G3ZA.

#### Communications Specifications

<b>Transmission path connections</b>	Multipoint
<b>Communications method</b>	RS-485
<b>Sync method</b>	Stop-start sync
<b>Baud rate</b>	9.6, 19.2, 38.4 or 57.6 kbit/s
<b>Transmission code</b>	ASCII
<b>Data length</b>	7 or 8 bits
<b>Stop bits</b>	1 or 2 bits
<b>Error detection</b>	Vertical parity: None, even, or odd
<b>Flow control</b>	None

Communications settings are made as shown in the following table.

Setting	Setting range	Default	Setting method
Communications unit number	0 to 31	1	SW1
Baud rate	9.6, 19.2, 38.4 or 57.6 kbit/s	9.6 kbit/s	SW2
Data length	7 or 8 bits	7 bits	Communications
Stop bits	1 or 2 bits	2 bits	Communications
Parity	None, even, odd	Even	Communications
Send standby time	0 to 99 ms	1 ms	Communications

#### Setting the Communications Unit Number and Baud Rate

The communications unit number and baud rate are set first. These settings are made with SW1 and SW2 on the front of the G3ZA.

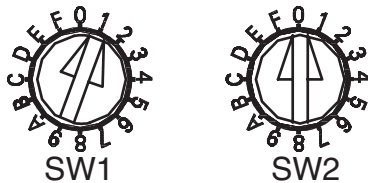

SW1	0	1	2	3	4	5	6	7	8	9	A	B	C	D	E	F
Unit number	00	01	02	03	04	05	06	07	08	09	10	11	12	13	14	15

SW2	0	1	2	3
Baud rate (kbit/s)	9.6	19.2	38.4	57.6

- Note**
- (1) Refer to *Connecting More Than 16 Controllers* on page 64 in the *Appendix* when connecting more than 16 Controllers.
  - (2) The default settings are shaded in the above table.
  - (3) When connecting to the EJ1, set SW2 to 3.

**Other Communications Settings**

Communications are used to set the data length, number of stop bits, parity, and send standby time. To change the settings, use communications with the default communications settings. Refer to 3-4 Variable Area Write on page 23 for the procedure for changing these settings.

**Note** The settings will be enabled only when the power is turned ON again or the G3ZA is software reset.

**Send Standby Time**

The send standby time is used to adjust the time required for the host to switch from sending to receiving status. For the G3ZA, this adjusts the time between creating a response after receiving a transmission and switching to send status.

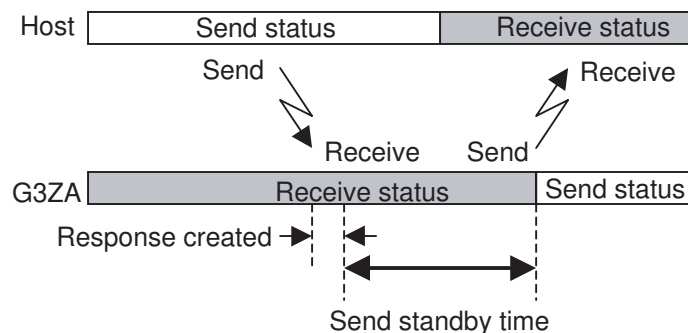

If switching time will not cause problems, the send standby time can be shortened to reduce the communications time with the host.

**3-2 Frame Configuration**

The communications protocol is the OMRON CompoWay/F protocol. Commands from the host and responses from the G3ZA are sent in data packets called frames. The structures of the command and response frames are shown below.

In the following explanations, hexadecimal values are expressed by adding the suffix H after the number, e.g., 02H. All other alphanumeric values in the explanations indicate ASCII characters.

**Command Frame Format**

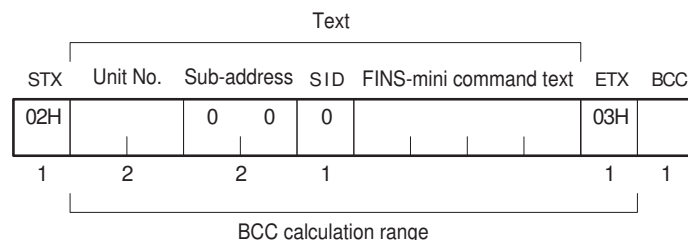

**Response Frames**

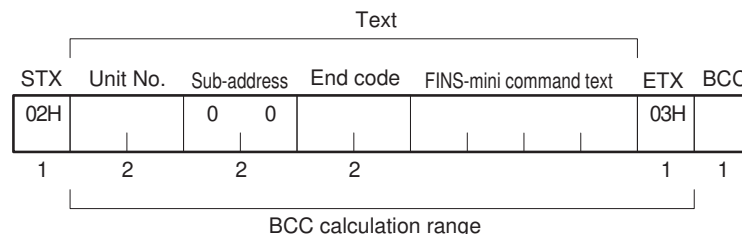

STX	This code indicates the beginning of the communications frame. Always set 02H.
Unit. No.	<ul style="list-style-type: none"> <li>• Set the unit number that is set on SW1 on the front of the G3ZA.</li> <li>• No response will be received if another unit number is set.</li> </ul>
Sub-address and SID	Not used by the G3ZA. Always set to 0.
FINS-mini command text	This text is the command. For details, refer to <i>3-6 Operation Command</i> on page 25.
ETX	This code indicates the end of the communications frame. Always set to 03H.
BCC	This stores the result of the BCC calculation from the Unit No. to ETX.

**BCC Calculation Example**

STX	Unit No.	Sub-address	SID	FINS-mini command text	ETX	BCC
02H	30H 30H	30H 30H	30H	30H 35H 30H 30H	03H	36H

BCC = 30H ⊕ 30H ⊕ 30H ⊕ 30H ⊕ 30H ⊕ 30H ⊕ 35H ⊕ 30H ⊕ 30H ⊕ 03H = 36H  
 ⊕ : XOR (exclusive OR) calculation

**Note** No response will be returned unless the frame contains all elements up to the ETX and BCC.

**End Codes (CompoWay/F Communications)**

End code	Name	Description	Error detection priority
"0F"	FINS command error	The specified FINS command could not be executed.	8
"10"	Parity error	The OR of 1 bits in received data does not match the setting for the communications parity.	2
"11"	Framing error	Stop bit is "0".	1
"12"	Overrun error	The next data was received when the reception data buffer was full.	3
"13"	BCC error	The calculated BCC value is different from the received BCC value.	5
"14"	Format error	The FINS-mini command text contains characters other than 0 to 9 and A to F. For details on the echoback test, refer to <i>3-9 Echo-back Test</i> on page 28. SID and the FINS-mini command text are not included.	7
"16"	Sub-address error	The sub-address is not included.	6
"18"	Frame length error	The received frame exceeds the required number of bytes.	4
"00"	Normal completion	Command processing was completed normally.	None

**■ End Code Example**

When the Sub-address, SID, and FINS-mini Command Text Are Not Included

- Command

STX	Unit No.	ETX	BCC
02H	0 1	03H	

- Response

STX	Unit No.	Subaddress	End code	ETX	BCC
02H	0 1	0 0	1 6	03H	

The sub-address is "00" and the end code is "16" (sub-address error).

### 3-3 FINS-mini Text

The FINS-mini command and response text is the text that form the command and response communications.

The structure of FINS command and response text is shown below.

#### Command Text

An MRC (main request code) and SRC (sub-request code) followed by the various required data is transferred in the command frame.

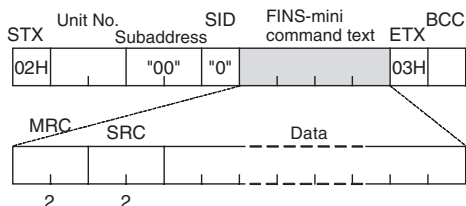

#### Response Text

The MRES (main response code) and SRES (sub-response code) are transferred in the response frame following the above MRC/SRC. Data is then transferred following the MRES and SRES.

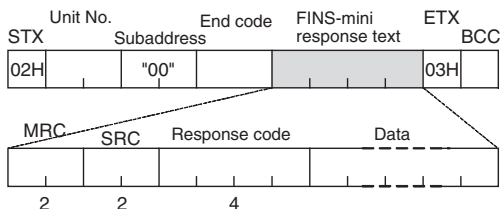

#### Variable Type and Address

**Note** Refer to *Parameter List* on page 66.

#### Number of Elements

The number of elements is expressed in 2-byte hexadecimal format. The range for specifying the number of elements differs for each command. Refer to *3-4 Variable Area Write* or *3-5 Variable Area Read*.

#### Communications Data

Setting (monitor) value	Communications data (See note.)	Negative values	Decimal point
Hexadecimal	Double word (8 digits) Word (4 digits)	2's complement	The decimal point is removed and the result is converted to hexadecimal. Example) 105.0 → 1050 → 0000041A (8 digits) 105.0 → 1050 → 041A (4 digits)

**Note** Refer to *Parameter List* on page 66.

## List of FINS-mini Service Commands

MRC	SRC	Service name	Description
"01"	"02"	Variable Area Write	Changes set values.
"01"	"01"	Variable Area Read	Reads set values.
"30"	"05"	Operation Command	Executes commands such as start/stop, manipulated variable save and software reset.
"05"	"03"	Controller Attribute Read	Reads the model number of the Controller.
"06"	"01"	Controller Status Read	Reads the operating status.
"08"	"01"	Echo-back Test	Performs an echo-back test.

**Note** FINS is an acronym for Factory Interface Network Service. FINS is a protocol used for message communications between controllers on OMRON FA networks.

## 3-4 Variable Area Write

This command changes set values.

### Command

MRC	SRC	Variable type	Write start address	Bit position	No. of elements	Set values
"01"	"02"			"00"		
2	2	2	4	2	4	No. of elements x 8 or 4

**Note** In the G3ZA, the bit position is not used. Set it to "00".

### Response

MRC	SRC	Response code
"01"	"02"	
2	2	4

#### ■ Variable Type and Write Start Address

Refer to the *Parameter List* on page 66 in the *Appendix*.

#### ■ Number of Elements

Specify the number of elements for which the set value is to be changed. Up to 24 (0018H) elements can be specified.

Write data length	No. of elements
For double-word (8-digit) variable type	24 max. (0018H)
For word (4-digit) variable type	48 max. (0030H)

#### ■ Response Code

Response code	Error name	Cause
"1002"	Command length too short	The command is too short.
"1101"	Area type error	The specified variable type does not exist.
"1003"	Number of elements/Number of data do not agree	The specified number of elements does not agree with the actual number of data elements.
"1100"	Parameter error	The bit position specification is not "00". A set value is outside of the setting range.
"2203"	Operation error	An error occurred in nonvolatile memory.
"0000"	Normal end	Processing was completed normally.

**Example:** The following command changes the manipulated variable for channel 1 to 50% (set value: 8 digits).

Command: [STX]010000102C10000000001000001F4[ETX][BCC]

Response: [STX]01000001020000[ETX][BCC]

**Example:** The following command changes the manipulated variable for channel 1 to 50% (set value: 4 digits).

Command: [STX]01000010281000000000101F4[ETX][BCC]

Response: [STX]01000001020000[ETX][BCC]



### 3-5 Variable Area Read

This command reads set values.

#### Command

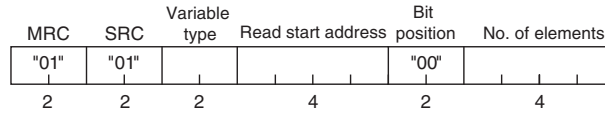

**Note** In the G3ZA, the bit position is not used. Set it to "00".

#### Response

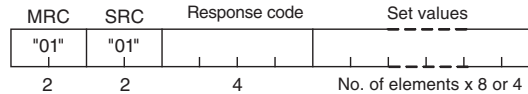

■ **Variable Type and Read Start Address**

Refer to the *Parameter List* on page 66 in the *Appendix* .

■ **Number of Elements**

Specify the number of elements for which the set value is to be read. Up to 25 (0019H) elements can be specified.

Read data length	No. of elements
For double-word (8-digit) variable type	25 max. (0019H)
For word (4-digit) variable type	50 max. (0032H)

■ **Response Code**

Response code	Error name	Cause
"1001"	Command length too long	The command is too long.
"1002"	Command length too short	The command is too short.
"1101"	Area type error	The specified variable type does not exist.
"110B"	Response length too long	The number of elements is larger than the maximum number allowed.
"1100"	Parameter error	The bit position specification is not "00".
"2203"	Operation error	An error occurred in nonvolatile memory.
"0000"	Normal end	Processing was completed normally.

**Example:** The following command reads the control variable for channel 1 (set value: 8 digits).

Command: [STX]010000**101C00001000001**[ETX][BCC]

Response: [STX]010000**1010000000000000**[ETX][BCC]

**Example:** The following command reads the control variable for channel 1 (set value: 4 digits).

Command: [STX]010000**101800001000001**[ETX][BCC]

Response: [STX]010000**10100000000**[ETX][BCC]

■ **Precautions**

- "0" is set when an address with no data set is read.

### 3-6 Operation Command

This command is used to start and stop operation, save the manipulated variable, execute a software reset, or initialize settings.

#### Command

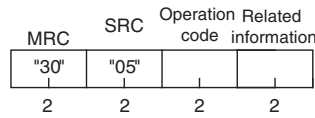

#### Response

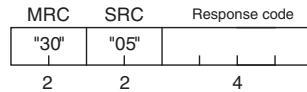

#### 1. Operation Code and Related Information

Operation code	Description	Related information	Operation
"01"	Start/stop	Upper digit: Channel specification "0": Channel 1 "1": Channel 2 "2": Channel 3 "3": Channel 4 "4": Channel 5 "5": Channel 6 "6": Channel 7 "7": Channel 8 "F": All channels Lower digit: Start/stop "0": Start "1": Stop	Refer to 4-12 Turning OFF a Control Output (4 and 8-channel Models) on page 52.
"05"	Manipulated variable save	"00"	Refer to 4-10 Changing the Manipulated Variable (4 and 8-channel Models) on page 50.
"06"	Software reset	"00"	Performs the same processing as when the G3ZA is turned ON.
"0B"	Initialize settings	"00"	Refer to 5-2 Handling Problems.

**Note** There is no response for a software reset. Responses are returned for all other operation codes.

#### 2. Response Codes

Response code	Error name	Cause
"1001"	Command length too long	The command is too long.
"1002"	Command length too short	The command is too short.
"1100"	Parameter error	The operation code or related information is not correct.
"2203"	Operation error	An error occurred in nonvolatile memory.
"0000"	Normal end	Processing was completed normally.

**Example:** The following command starts operation for channel 1.

Command: [STX]0100030050100[ETX][BCC]

Response: [STX]01000030050000[ETX][BCC]

### 3-7 Controller Attribute Read

This command reads the model number of the Controller and the communications buffer size.

#### Command

MRC	SRC
"05"	"03"
2	2

#### Response

MRC	SRC	Response code	Model number	Buffer size
"05"	"03"		"G3ZA-"	"00D9"
2	2	4	10	4

#### 1. Model Number

G	3	Z	A	-	①	②	③	④	⑤
---	---	---	---	---	---	---	---	---	---

Number	Code	Meaning
①	"4"	4 channels
	"8"	8 channels
②	"H"	With current transformer input
	"A"	No current transformer input
③	"2"	Load power supply: 100 to 240 V
	"4"	Load power supply: 400 to 480 V
④⑤	"03"	RS-485

#### 2. Buffer Size

The communications buffer size is expressed in 2-byte hexadecimal, and read after being converted to 4-byte ASCII.

The buffer size is 217 bytes (D9H).

#### 3. Response Code

Response code	Error name	Cause
"1001"	Command length too long	The command is too long.
"2203"	Operation error	An error occurred in nonvolatile memory.
"0000"	Normal end	Processing was completed normally.

**Example:** The following command reads the model number and buffer size. The response shows the Controller has four channels, supports a current transformer, and has a load power supply of 400 to 480 V.

Command: [STX]010000503[ETX][BCC]

Response: [STX]01000005030000G3ZA-4H40300D9[ETX][BCC]

Communications (CompoWay/F)

### 3-8 Controller Status Read

This service reads the operating status and error status.

#### Command

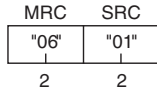

#### Response

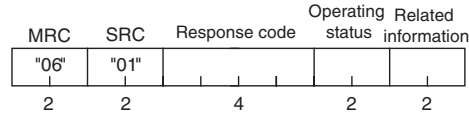

#### 1. Operating Status

Operating status	Meaning
"00"	The control output is ON for one or more channels.
"01"	The Controller is stopped or a zero cross error has occurred during operation.

#### 2. Related Information

An OR of status bits 0 to 7 for all channels.

Refer to the *Status* in the *Status Lists* on page 65 in the *Appendix*.

#### Note

To read the status of individual channels, use the *Variable Area Read* command for the desired channel. Refer to *3-5 Variable Area Read* for details.

#### 3. Response Code

Response code	Error name	Cause
"1001"	Command length too long	The command is too long.
"2203"	Operation error	An error occurred in nonvolatile memory.
"0000"	Normal end	Processing was completed normally.

#### Example:

Command: [STX]010000601[ETX][BCC]

Response: [STX]01000060100000100[ETX][BCC]

### 3-9 Echo-back Test

This command performs an echo-back test.

#### Command

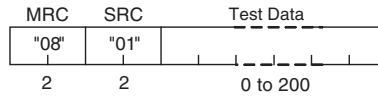

#### Response

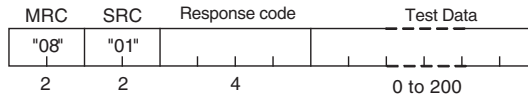

##### 1. Test Data

The test data can contain up to 200 (00C8H) bytes.

Set the test data within the following ranges according to the communications data length setting.

Data length	Test data
7 bits	ASCII 20H to 7EH
8 bits	ASCII 20H to 7EH or A1H to FEH

##### 2. Response Codes

Response code	Error name	Cause
"1001"	Command length too long	The command is too long.
"2203"	Operation error	An error occurred in nonvolatile memory.
"0000"	Normal end	Processing was completed normally.

#### Example:

Command: [STX]010000**0801123**[ETX][BCC]

Response: [STX]010000**08010000123**[ETX][BCC]

# SECTION 4

## Functions

This section describes the functions of the G3ZA so that these functions can be used effectively according to the application.

4-1	Setup Procedure	30
4-2	Selecting the SSR (Control Method) 4 or 8-channel Models <b>V2</b>	31
4-3	Selecting the CT (4-channel Models Only) <b>V2</b>	33
4-4	Allocating CTs (4-channel Models Only) <b>V2</b>	35
4-5	Detecting Heater Burnouts (4-channel Models Only)	36
4-6	Detecting Heater Overcurrent (4-channel Models Only)	43
4-7	Detecting SSR Short-Circuits (4-channel Models Only)	45
4-8	Detecting Communications Timeouts (4 and 8-channel Models)	48
4-9	Setting the Soft Increase and Soft Decrease Times (4 and 8-channel Models) <b>V2</b>	49
4-10	Changing the Manipulated Variable (4 and 8-channel Models)	50
4-11	Offsetting the Control Output's ON Timing (4 and 8-channel Models)	51
4-12	Turning OFF a Control Output (4 and 8-channel Models)	52
4-13	Setting the Abnormal Current Detection Delay (4 and 8-channel Models) <b>V2</b>	52
4-14	Setting Operation at Error (4 and 8-channel Models)	53
4-15	Monitoring the Effective Current <b>V2</b>	54

# 4-1 Setup Procedure

The following flowchart shows the setup procedure for the G3ZA. Make the settings required for the application being used.

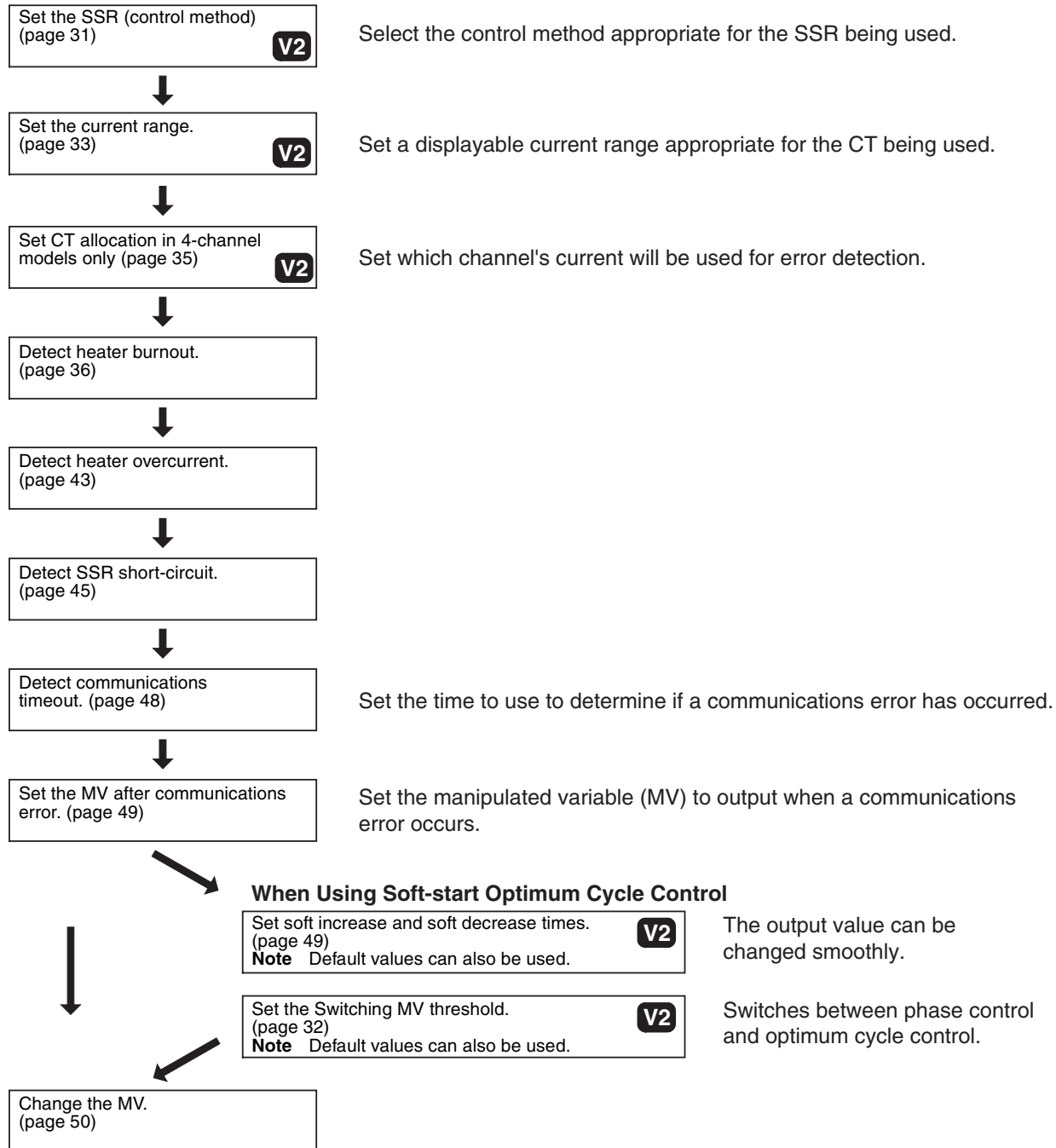

## 4-2 Selecting the SSR (Control Method) 4 or 8-channel Models) **V2**

The following kinds of SSRs can be selected to control operation: SSRs for single-phase heaters with zero-cross function, SSRs for single-phase heaters without zero-cross function, SSRs for three-phase heaters with zero-cross function.

The default setting is for SSRs for single-phase heaters with zero-cross function. Select the appropriate control method for the application being used.

Variable type	Parameter name	Setting range	Example application	Default
83/C3	SSR Selector	0: SSR for single-phase heater with zero-cross function: Optimum cycle control 1: SSR for single-phase heater without zero-cross function: Soft-start optimum cycle control 2: SSR for three-phase heater with zero-cross function: Three-phase optimum cycle control	Single-phase heater  Single-phase halogen heater  Three-phase heater	0

**Example:** Setting the SSR Selector to an SSR for Single-phase Heaters without Zero-cross Function

1,2,3...

1. Set the SSR Selector to 1 with a Variable Area Write command.
2. After setting the SSR Selector, enable the new setting by executing a software reset with an Operation Command or turning the power OFF and then ON again.

### Optimum Cycle Control

- Optimum cycle control is a control method in which the outputs are turned ON/OFF each half cycle.
- Turning the outputs ON/OFF each half cycle can provide high-speed response and high-precision temperature control while suppressing noise.
- Use SSRs for single-phase heaters (with zero-cross function) for optimum cycle control.

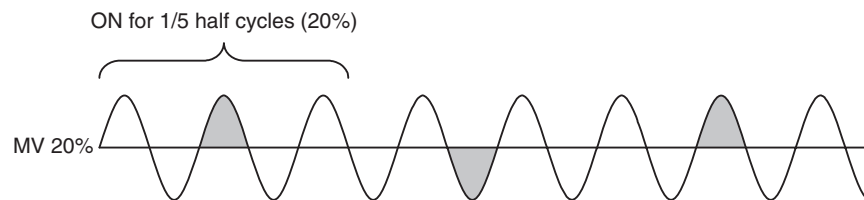

**Note** The image shows a current waveform with an MV of 20%.

### Soft-start Optimum Cycle Control

- Soft-start optimum cycle control is a control method that combines phase control and optimum cycle control.
- By smoothly switching between phase control and optimum cycle control, it is possible to control the output and suppress the inrush current even with loads with characteristics like halogen heaters.
- Use SSRs for single-phase heaters (without zero-cross function) for soft-start optimum cycle control.
- The control method is switched at the Switching MV threshold.



- Set the soft increase and soft decrease times to control the output. For details on these settings, refer to 4-9 Setting the Soft Increase and Soft Decrease Times (4 and 8-channel Models) on page 49.
- Current detection is not performed during phase control. The current values (heater ON current, heater OFF current, and actual current) will be 0 A, and the current alarms (heater burnout detection, heater overcurrent detection, and SSR short-circuit detection) will always be OFF.

**Setting the Switching MV Threshold**

The Switching MV Threshold is used in soft-start optimum cycle control. By setting the Switching MV Threshold, the control method can be switched to phase control below the set value and optimum cycle control above the set value.

The default value is set to 20%.

Variable type	Parameter name	Setting range	Default
85/C5	Switching MV threshold for channels 1 to 8	0.0% to 100.0%	20.0

**Example:** Performing Soft-start Optimum Cycle Control in Channel 1 with a Switching MV Threshold of 40.0%, an MV of 100.0%, and a Soft Increase Time of 20 s

1,2,3...

1. Set the Channel 1 Switching MV Threshold to 40.0%, and the Channel 1 MV to 100.0% with a Variable Area Write command.
2. The channel 1 Soft Increase time is kept at its default value, so it is not necessary to set this value.
3. Once the Channel 1 Switching MV Threshold is written, the setting is saved, and will also be effective the next time that the power is turned ON.

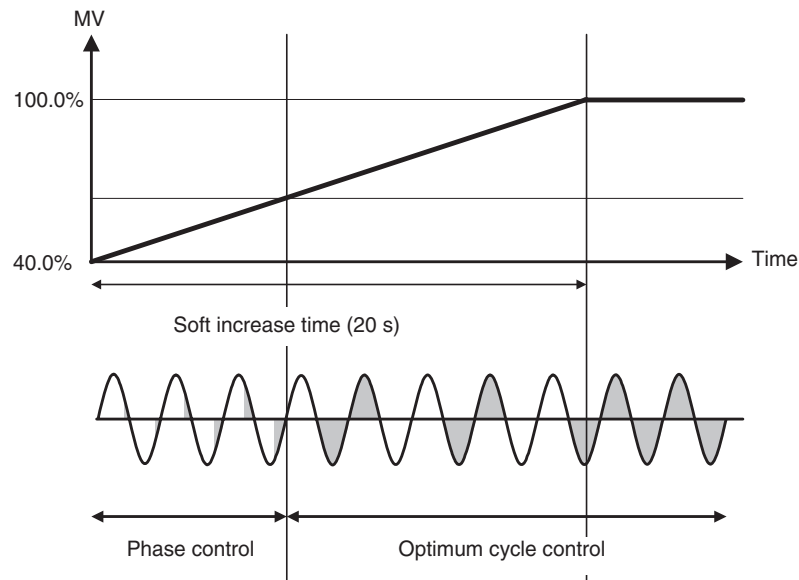

**Note** The image shows a current waveform.

**Three-phase Optimum Cycle Control**

- Three-phase optimum cycle control is a control method in which the outputs are turned ON/OFF every two cycles.
- Turning the outputs ON/OFF every two cycles allows optimum cycle control to be used with three-phase heaters.
- Use SSRs for three-phase heaters with zero-cross function for three-phase optimum cycle control.

The following diagram shows an example connection to a three-phase heater.

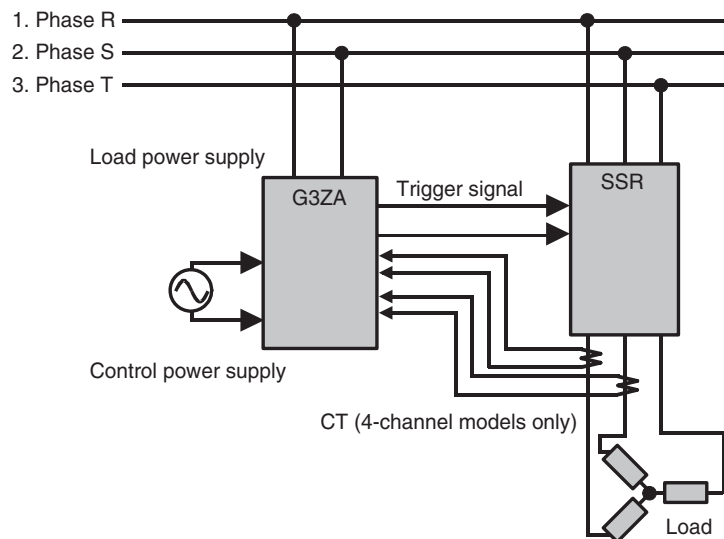

When the G3ZA is connected as shown above and the MV is 50%, the phases will have the current waveforms shown in the following diagram.

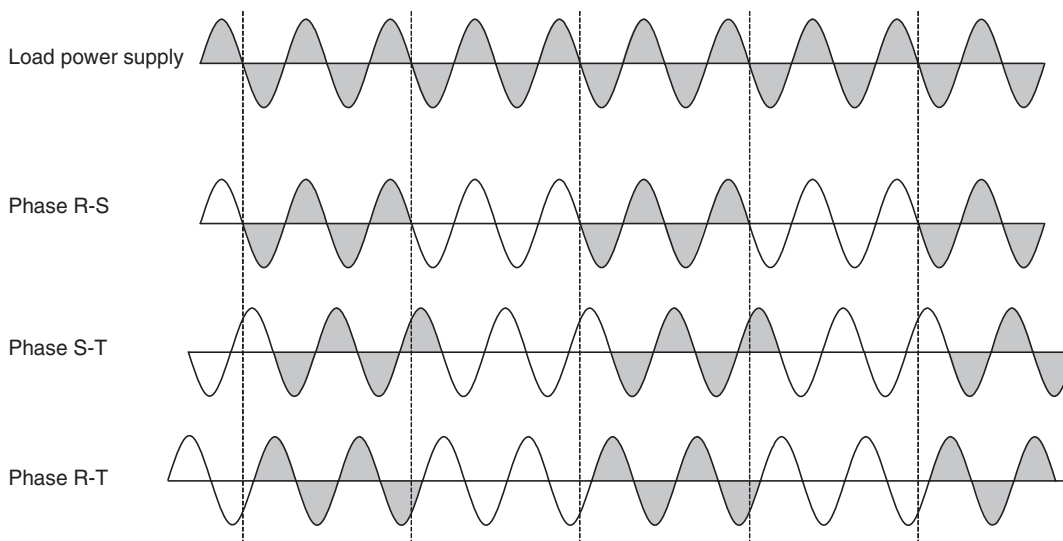

### 4-3 Selecting the CT (4-channel Models Only) **V2**

The selected CT setting determines the displayable current range, as shown in the following table.

Variable type	Parameter name	Setting	Min. monitor value	Max. monitor value (See note 3.)	Default
83/C3	Current Monitor Selector (See note 1.)	0: (0 to 50 A)	0 A	55 A (See note 3.)	0 (0 to 50 A)
		1: (0 to 150 A)	0 A	165 A (See note 3.)	
		2: (0% to 100%) (See note 2.)	0%	110% (See note 3.)	

- Note**
- (1) The resolution of the monitor display is as follows.
    - 0 to 50 A range selected: 1 A
    - 0 to 150 A range selected: 3 A
    - 0% to 100% range selected: 2%
  - (2) The heater burnout detection, heater overcurrent detection, and SSR short-circuit detection values must be set as percentages.
  - (3) When the input exceeds the maximum value, the display will overflow at the maximum value.
    - Example:** If the range is 0 to 50 A and the input is 60 A, the display will overflow at 55 A.
    - Example:** If the range is 0 to 150 A and the input is 170 A, the display will overflow at 165 A.
    - Example:** If the range is 0% to 100% and the input is 115%, the display will overflow at 110%.

When the percentage input is selected, the maximum current value measurable with the CT is measured as 100%.

For example, the following percentages will be displayed when a 30-A current is flowing in the heater.

- If a E54-CT1 (0 to 50 A) CT is being used, 60% is displayed.
- If a G3ZA-CT150L (0 to 150 A) CT is being used, 20% is displayed.

Similarly, the heater burnout detection, heater overcurrent detection, and SSR short-circuit detection values are also detected as percentages.

### Setting Procedure

The following examples show how to select a suitable CT and set the Current Monitor Selector.

- Select the CT.
  - Detecting current in the 0 to 50 A range  
→ Select a CT for 0 to 50 A detection (E54-CT1 or E54-CT3).
  - Detecting current in the 0 to 150 A range  
→ Select a CT for 0 to 150 A detection (G3ZA-CT150L).
- Set the Current Monitor Selector to match the CT selected above.
  - If a CT for 0 to 50 A detection is selected:  
→ Set the Current Monitor Selector to 0 (0 to 50 A) or 2 (0% to 100%).
  - If a CT for 0 to 150 A detection is selected:  
→ Set the Current Monitor Selector to 1 (0 to 150 A) or 2 (0% to 100%).

**Example:** Setting the Current Monitor Selector to the 0 to 150 A Range

1,2,3...

1. Set the Current Monitor Selector to 1 with a Variable Area Write command.
2. After setting the Current Monitor Selector, enable the new setting by executing a software reset with an Operation Command or turning the power OFF and then ON again.

### CT Current Monitors

#### CT for 0 to 50 A Detection (E54-CT1 or E54-CT3) Selected

The following table shows representative currents that are detected.

Current Monitor Selector setting	0: 0 to 50 A	1: 0 to 150 A (See note 1.)	2: 0% to 100% (See note 2.)
Minimum monitored value	0 A	---	0%
	10 A	---	20%
	50 A	---	100%
Maximum monitored value	55 A	---	110%

- Note**
- (1) When a CT for 0 to 50 A detection is selected, do not set the Current Monitor Selector to 1 (0 to 150 A). The correct current value cannot be detected if it is set to 1.
  - (2) When the Current Monitor Selector is set to 2 (0% to 100%), the current will be displayed as a percentage of the connected CT's range. (For example, the current will be 100% for a 50-A current flowing through a CT for 0 to 50 A detection, as shown in the table above.)

**CT for 0 to 150 A Detection (G3ZA-CT150L) Selected**

The following table shows representative currents that are detected.

Current Monitor Selector setting	0: 0 to 50 A	1: 0 to 150 A (See note 1.)	2: 0% to 100% (See note 2.)
<b>Minimum monitored value</b>	---	0 A	0%
	---	30 A	20%
	---	150 A	100%
<b>Maximum monitored value</b>	---	165 A	110%

- Note**
- (1) When a CT for 0 to 150 A detection is selected, do not set the Current Monitor Selector to 0 (0 to 50 A). The correct current value cannot be detected if it is set to 0.
  - (2) When the Current Monitor Selector is set to 2 (0% to 100%), the current will be displayed as a percentage of the connected CT's range. (For example, the current will be 100% for a 150-A current flowing through a CT for 0 to 150 A detection, as shown in the table above.)

## 4-4 Allocating CTs (4-channel Models Only) **V2**

The CT allocation settings specify which currents are measured for the outputs of channels 1 to 4. When detecting abnormal current in a single-phase heater, leave these settings at their default settings.

A heater burnout can be detected in a three-phase heater by allocating two CTs to one output.

Variable type	Parameter name	Setting range	Default
83/C3	CT1 Allocation	0: Disabled	1
	CT2 Allocation	1: Channel 1	2
	CT3 Allocation	2: Channel 2	3
	CT4 Allocation	3: Channel 3	4
		4: Channel 4	

**Example Settings for Detection of Three-phase Heater Burnout**

The following measurements can be made when the CTs are connected as shown in the following diagram, CT1 Allocation is set to 1 (channel 1), CT2 Allocation is set to 1 (channel 1), CT3 Allocation is set to 2 (channel 2), and CT4 Allocation is set to 2 (channel 2).

- The channel 1 outputs are synchronized and the current inputs to CT1 and CT2 are measured.
- The channel 2 outputs are synchronized and the current inputs to CT3 and CT4 are measured.

In this example, all of the CT inputs (4 inputs) are allocated to channels 1 and 2, so a three-phase heater burnout cannot be detected in channels 3 and 4.

**Loads Connected to Channel 1**

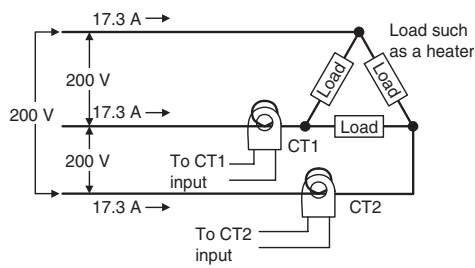

CT1: Measures the current of channel 1.  
 CT2: Measures the current of channel 1.

**Loads Connected to Channel 2**

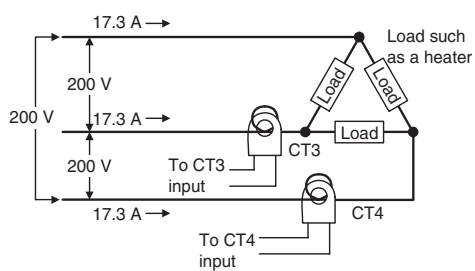

CT3: Measures the current of channel 2.  
 CT4: Measures the current of channel 2.

For details on heater burnout detection, refer to 4-5 *Detecting Heater Burnouts (4-channel Models Only)*.

## 4-5 Detecting Heater Burnouts (4-channel Models Only)

A heater burnout is detected by determining if the heater current is below the heater burnout detection value when a control output is ON. In addition, the abnormal current detection delay can be set to prevent noise from causing false burnout detection.

### Setting Procedure

Make the following settings to detect heater burnout. If these settings are not made, heater burnout may not be detected properly.

- Wire the CTs.
- Calculate the detection value as described under the heading *Calculating the Heater Burnout Detection Value* on page 39, and set the heater burnout detection value.
- Set the abnormal current detection delay as described in 4-13 *Setting the Abnormal Current Detection Delay (4 and 8-channel Models)* **V2** on page 52

**Heater Burnout  
Detection Timing**

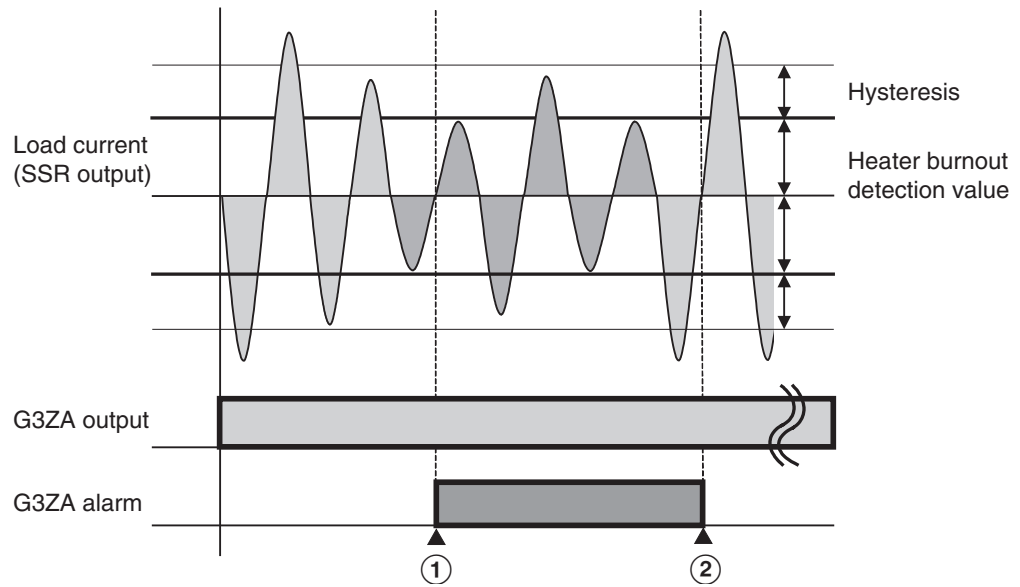

**Note** This example shows operation with the following settings:  
 Abnormal current detection delay = 0 (immediate alarm)  
 Operation at error = 0 (Continue with error clear)

- Heater burnout is detected at point 1 in the diagram above. The detection condition is as follows:  
 Heater ON current (see note 1)  $\leq$  Heater burnout detection value.
- The heater burnout alarm is cleared at point 2 in the diagram above. The clearing condition is as follows:  
 Heater ON current (see note 1)  $\geq$  Heater burnout detection value + Hysteresis (see note 2)

- Note**
- (1) The heater ON current is the peak load current that flows when the G3ZA's output is ON.
  - (2) The hysteresis setting applies a dead zone between the detection condition and clearing condition, which prevents ON/OFF chattering of the alarm. The same hysteresis setting is used for the heater burnout detection, heater overcurrent detection, and SSR short-circuit detection functions.

Variable type	Parameter name	Setting range	Default
81/C1	Channel 1 to 4 heater burnout detection value	0 to 50 A (See note.)	0 (Disabled)
	CT 1 to 4 heater burnout detection value ( <b>V2</b> )	0 to 165 A, or % (See note.)	0 (Disabled)
83/C3	Hysteresis	1 to 10 A, or %	1

**Note** If set to 0 A, heater burnout will not be detected.  
 If set to 50 A (or 165 A in the **V2** models), detection is forced. Use these settings to confirm operation during installation.

**Setting Ranges Supported in the V2 Models (0 to 165 A, or %)**

The current range and units are determined by the Current Monitor Selector setting.

Variable type	Parameter name	Setting	Current range	Units
83/C3	Current Monitor Selector	0	0 to 55	A
		1	0 to 165	A
		2	0 to 110	%

**Note** Detection values of 0 to 165 (A or %) max. can be detected, but set the detection value appropriate for the current range. If the detection value is set above the current range, errors will not be detected. Refer to 4-3 *Selecting the CT (4-channel Models Only)* V2 on page 33 for details on detection values.

**Example:** Setting the CT1 Heater Burnout Detection Value to 20 A

- 1,2,3...
1. Set the CT1 heater burnout detection value to 20 with a Variable Area Write command.
  2. The current is detected in CT1, and heater burnout is detected with the timing shown in the diagram on the preceding page.
  3. Once the CT1 heater burnout detection value is written, the setting is saved, and will also be effective the next time that the power is turned ON.

**Precautions**

- Turn ON the heater power supply at the same time or before turning ON the G3ZA power supply. False detection will occur if the heater power supply is turned ON after the G3ZA power supply.
- The actual current flowing in the heater may not be the same as the heater's rated current. Check the heater current under actual conditions using the CT1 to CT4 Heater ON currents.
- Detection will be unstable if there is only a small difference between the normal current and burnout current. To achieve stable detection, set the parameters as follows.
  - For a Current Monitor Selector setting of 0 (0 to 50 A):
    - Heaters of less than 10 A: (Normal current - Burnout current) ≥ 2 A  
Detection will not be stable if the difference is less than 2 A.
    - Heaters of 10 A or more: (Normal current - Burnout current) ≥ 3 A  
Detection will not be stable if the difference is less than 3 A.
  - For a Current Monitor Selector setting of 1 (0 to 150 A):
    - Heaters of less than 10 A: (Normal current - Burnout current) ≥ 6 A  
Detection will not be stable if the difference is less than 6 A.
    - Heaters of 10 A or more: (Normal current - Burnout current) ≥ 9 A  
Detection will not be stable if the difference is less than 9 A.
  - For a Current Monitor Selector setting of 2 (0% to 100%):
    - Heaters of less than 10 A: (Normal current - Burnout current) ≥ 4%  
Detection will not be stable if the difference is less than 4%.
    - Heaters of 10 A or more: (Normal current - Burnout current) ≥ 6%  
Detection will not be stable if the difference is less than 6%.

If the conditions for stable detection cannot be met, increase the number of turns of the heater wire through the current transformer and increase the detection value. The monitored heater ON current value is proportional to the number of turns.

**Example:**

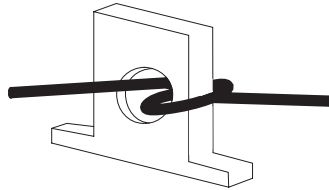

- Each channel's status can be read individually to check it for heater burn-out detection.

**Operation after Error Detection**

It is possible to select the Controller's operation after a heater burnout is detected.

For details on selecting operation after an error, refer to *4-14 Setting Operation at Error (4 and 8-channel Models)* on page 53.

**Calculating the Heater Burnout Detection Value**

Use the following formula to calculate the heater burnout detection value.

$$\text{Heater burnout detection value} = \frac{(\text{Normal current} + \text{Burnout current})}{2}$$

**Note** The result is an integer display.

When two or more heaters are connected through the current transformer, set the burnout detection value to detect burnouts on the heater with the smallest current. (If the heater currents are all the same, set the value for burnout of one wire.)

**Application Examples**

**1. Single-phase Heaters**

**Example 1: Using One 1-kW Heater (200 V AC)**

**Normal operation**

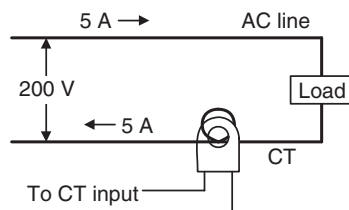

**Burnout occurred**

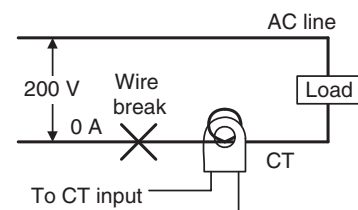

If the normal heater current is 5 A and the burnout heater current is 0 A, the heater burnout detection value is calculated as follows:

$$\text{Heater burnout detection value} = \frac{(\text{Normal current} + \text{Burnout current})}{2}$$

$$= \frac{5 + 0}{2} = 2.5 \rightarrow 2 \text{ [A]}$$



**Example 2: Using Three 1-kW Heaters (200 V AC)**

**Normal operation**

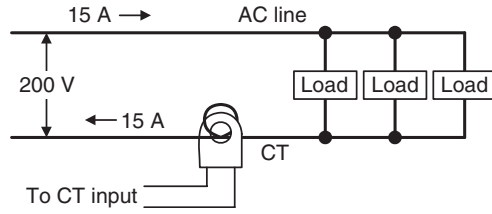

**Burnout occurred**

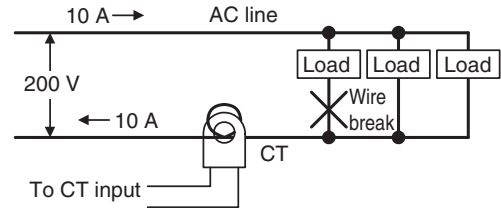

If the normal heater current is 15 A and the burnout heater current is 10 A, the heater burnout detection value is calculated as follows:

$$\begin{aligned} \text{Heater burnout detection value} &= \frac{(\text{Normal current} + \text{Burnout current})}{2} \\ &= \frac{15 + 10}{2} = 12.5 \text{ A} \rightarrow 12 \text{ [A]} \end{aligned}$$

**2. Three-phase Heaters**

**a. Delta Wiring**

**Example: Using Three 4-kW Heaters (200 V AC)**

**Normal Operation:**

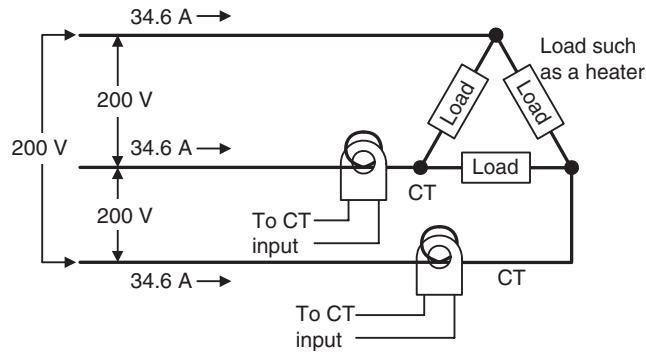

Each phase's normal current is 34.6 A.

$$34.6 \text{ A} (\doteq \sqrt{3} \times 20 \text{ A})$$

**Burnout Occurred:**

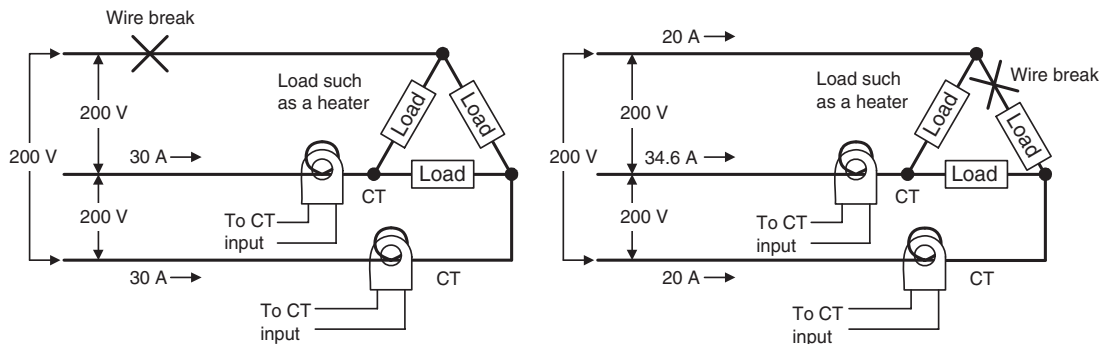

$$\begin{aligned} \text{Burnout current} &= 20 \text{ A} \times \sqrt{3} \times \left(\frac{\sqrt{3}}{2}\right) \\ &= 30 \text{ A} \end{aligned}$$

$$\begin{aligned} \text{Burnout current} &= 20 \text{ A} \times \sqrt{3} \times \left(\frac{1}{\sqrt{3}}\right) \\ &= 20 \text{ A} \end{aligned}$$

The following formula yields the heater burnout current when there is a break in the load wiring.

$$\text{Heater burnout detection value} = \frac{34.6 + 30}{2} = 32.3 \rightarrow 32 \text{ [A]}$$

The following formula yields the heater burnout current when there is a break in the load itself.

$$\text{Heater burnout detection value} = \frac{34.6 + 20}{2} = 27.3 \rightarrow 27 \text{ [A]}$$

To detect a wire break at either location, set a heater burnout detection value of 32 A.

**b. Star Wiring**

**Example:** Using three 6-kW heaters (200 V AC)

**Normal Operation:**

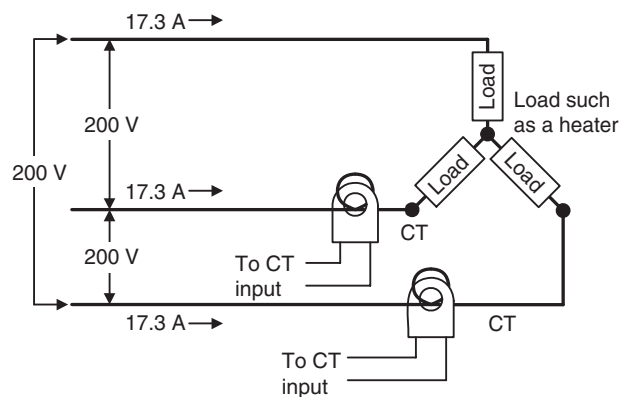

Each phase's normal current is 17.3 A.

$$17.3 \text{ A} \left( \doteq 30 \text{ A} \times \frac{1}{\sqrt{3}} \right)$$

**Burnout Occurred:**

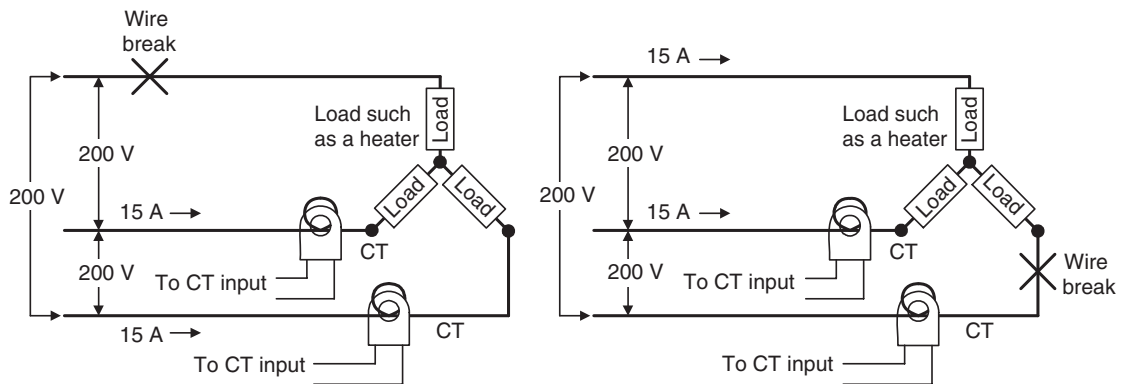

$$\begin{aligned} \text{Burnout current} &= 30 \text{ A} \times \left(\frac{1}{\sqrt{3}}\right) \times \left(\frac{\sqrt{3}}{2}\right) \\ &= 15 \text{ A} \end{aligned}$$

$$\begin{aligned} \text{Burnout current} &= 30 \text{ A} \times \left(\frac{1}{\sqrt{3}}\right) \times \left(\frac{\sqrt{3}}{2}\right) \\ &= 15 \text{ A} \end{aligned}$$

The following formula yields the heater burnout current for the main wiring.

$$\text{Heater burnout detection value} = \frac{17.3 + 15}{2} = 16.15 \rightarrow 16 \text{ [A]}$$

**c. V Wiring**

**Example:** Using two 2-kW heaters (200 V AC)

**Normal Operation:**

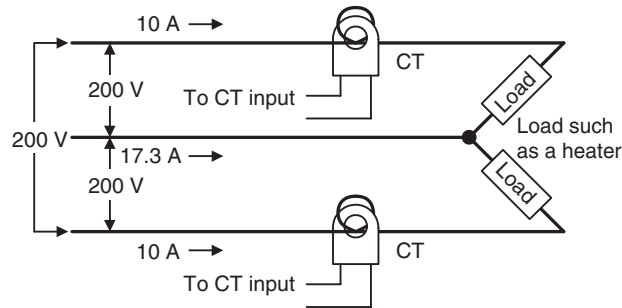

**Burnout Occurred:**

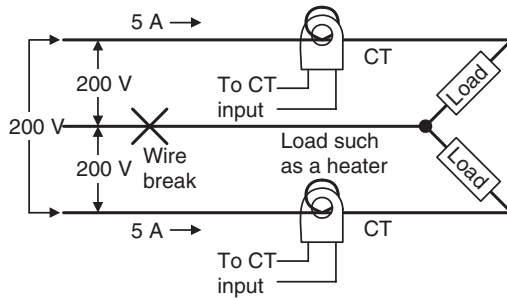

$$\begin{aligned} \text{Burnout current} &= 10 \text{ A} \times \frac{1}{2} \\ &= 5 \text{ A} \end{aligned}$$

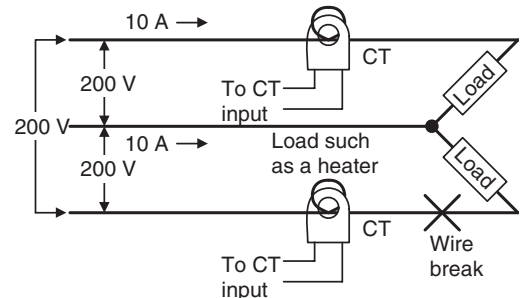

$$\text{Burnout current} = 0 \text{ A}$$

The following formula yields the heater burnout current when there is a break in the common wire.

$$\text{Heater burnout detection value} = \frac{10 + 5}{2} = 7.5 \rightarrow 7 \text{ [A]}$$

The following formula yields the heater burnout current when there is a break in the load wire.

$$\text{Heater burnout detection value} = \frac{10 + 0}{2} = 5 \text{ [A]}$$

To detect a wire break at either location, set a heater burnout detection value of 7 A.

## 4-6 Detecting Heater Overcurrent (4-channel Models Only)

Heater overcurrents are detected by determining whether the heater current is above the heater overcurrent detection value when a G3ZA control output is ON. The abnormal current detection delay can be set to prevent false overcurrent detection due to noise.

### Setting Procedure

Make the following settings to detect heater overcurrent. If these settings are not made, heater overcurrent may not be detected properly.

- Wire the CTs.
- Calculate the detection value that is appropriate for the application, and set the heater overcurrent detection value.
- Set the abnormal current detection delay as described in 4-13 *Setting the Abnormal Current Detection Delay (4 and 8-channel Models)* **V2** on page 52.

### Heater Overcurrent Detection Timing

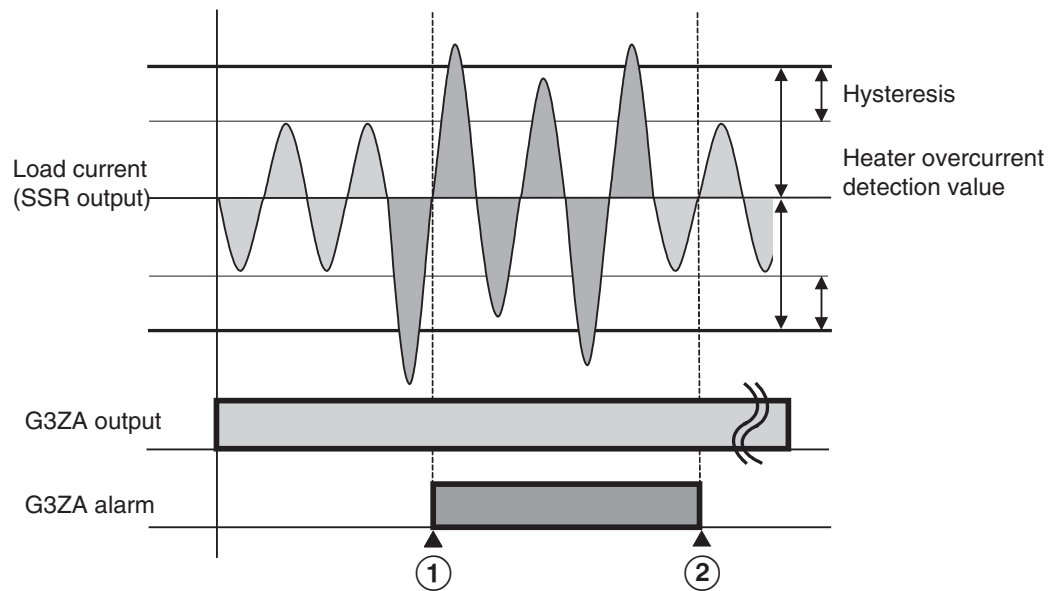

**Note** This example shows operation with the following settings:  
 Abnormal current detection delay = 0 (immediate alarm)  
 Operation at error = 0 (Continue with error clear)

- Heater overcurrent is detected at point 1 in the diagram above. The detection condition is as follows:  
 Heater ON current (see note 1)  $\geq$  Heater overcurrent detection value.
- The heater overcurrent alarm is cleared at point 2 in the diagram above. The clearing condition is as follows:  
 Heater ON current (see note 1)  $\leq$  Heater overcurrent detection value – Hysteresis (see note 2)

- Note**
- (1) The heater ON current is the peak load current that flows when the G3ZA's output is ON.
  - (2) The hysteresis setting applies a dead zone between the detection condition and clearing condition, which prevents ON/OFF chattering of the alarm. The same hysteresis setting is used for the heater burnout detec-

tion, heater overcurrent detection, and SSR short-circuit detection functions.

Variable type	Parameter name	Setting range	Default
81/C1	Channel 1 to 4 heater overcurrent detection value	0 to 50 A (See note.)	50 (Disabled)
	CT 1 to 4 heater overcurrent detection value ( <b>V2</b> )	0 to 165 A, or % (See note.)	165 (Disabled)
83/C3	Hysteresis	1 to 10 A, or %	1

**Note** If set to 50 A (or 165 A in the **V2** models), heater overcurrent will not be detected. If set to 0, detection is forced. Use these settings to confirm operation during installation.

**Setting Ranges Supported in the **V2** Models (0 to 165 A, or %)**

The current range and units are determined by the Current Monitor Selector setting.

Variable type	Parameter name	Setting	Current range	Units
83/C3	Current Monitor Selector	0	0 to 55	A
		1	0 to 165	A
		2	0 to 110	%

**Note** Detection values of 0 to 165 (A or %) max. can be detected, but set the detection value appropriate for the current range. If the detection value is set above the current range, errors will not be detected. Refer to 4-3 *Selecting the CT (4-channel Models Only)* **V2** on page 33 for details on detection values.

**Example:** Setting the CT1 Heater Overcurrent Detection Value to 20 A

- 1,2,3...**
1. Set the CT1 heater overcurrent detection value to 20 with a Variable Area Write command.
  2. The current is detected in CT1, and heater overcurrent is detected with the timing shown in the diagram on the preceding page.
  3. Once the CT1 heater overcurrent detection value is written, the setting is saved, and will also be effective the next time that the power is turned ON.

**Precautions**

- The actual current flowing in the heater may not be the same as the heater's rated current. Check the heater current under actual conditions using the CT1 to CT4 Heater ON currents.
- Detection will be unstable if there is only a small difference between the normal current and the overcurrent setting. To achieve stable detection, set the parameters as follows:
  - For a Current Monitor Selector setting of 0 (0 to 50 A):
    - Heaters of less than 10 A: (Normal current - Overcurrent setting) ≥ 2 A  
Detection will not be stable if the difference is less than 2 A.
    - Heaters of 10 A or more: (Normal current - Overcurrent setting) ≥ 3 A  
Detection will not be stable if the difference is less than 3 A.
  - For a Current Monitor Selector setting of 1 (0 to 150 A):
    - Heaters of less than 10 A: (Normal current - Overcurrent setting) ≥ 6 A  
Detection will not be stable if the difference is less than 6 A.

Heaters of 10 A or more: (Normal current - Overcurrent setting)  $\geq$  9 A  
 Detection will not be stable if the difference is less than 9 A.

- For a Current Monitor Selector setting of 2 (0% to 100%):

Heaters of less than 10 A: (Normal current - Overcurrent setting)  $\geq$  4%  
 Detection will not be stable if the difference is less than 4%.

Heaters of 10 A or more: (Normal current - Overcurrent setting)  $\geq$  6%  
 Detection will not be stable if the difference is less than 6%.

- Each channel's status can be read individually to check it for heater over-current detection.

**Operation after Error Detection**

It is possible to select the Controller's operation after a heater overcurrent is detected.

For details on selecting operation after an error, refer to *4-14 Setting Operation at Error (4 and 8-channel Models)* on page 53.

**Calculating the Heater Overcurrent Detection Value**

Set a heater overcurrent detection value appropriate for the customer's application.

**4-7 Detecting SSR Short-Circuits (4-channel Models Only)**

An SSR short-circuit is detected by determining whether the heater current is above the SSR short-circuit detection value when a G3ZA control output is OFF. The abnormal current detection delay can be set to prevent false SSR short-circuit detection due to noise.

**Setting Procedure**

Make the following settings to detect an SSR short-circuit. If these settings are not made, SSR short-circuits may not be detected properly.

- Wire the CTs.
- Calculate the detection value as described under the heading *Calculating the SSR Short-Circuit Detection Value* on page 47, and set the SSR short-circuit detection value.
- Set the abnormal current detection delay as described in *4-13 Setting the Abnormal Current Detection Delay (4 and 8-channel Models)* **V2** on page 52.

**SSR Short-Circuit  
Detection Timing**

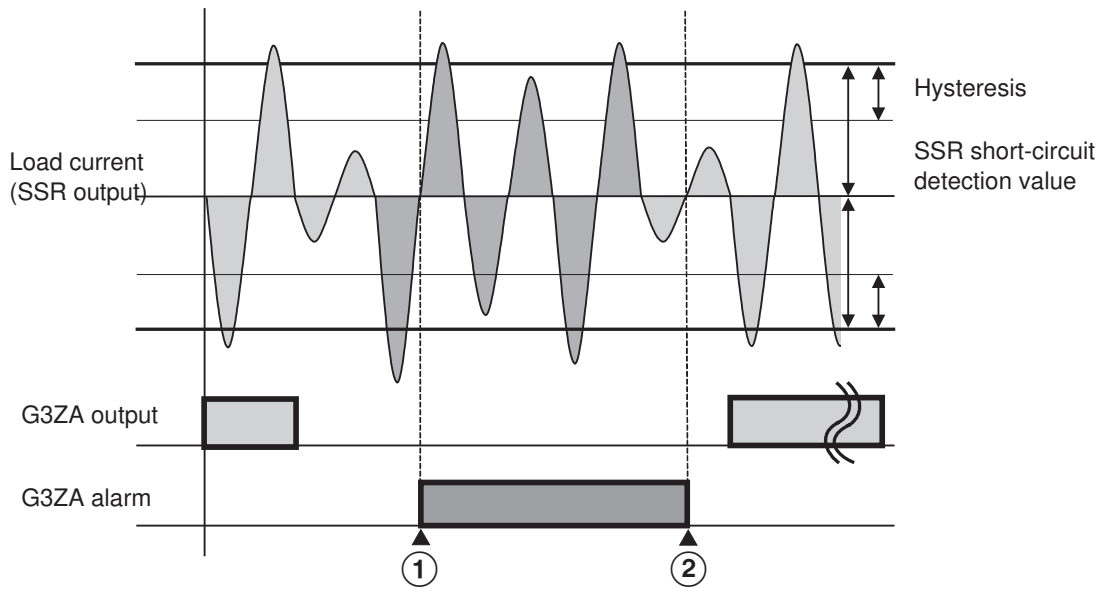

**Note** This example shows operation with the following settings:  
 Abnormal current detection delay = 0 (immediate alarm)  
 Operation at error = 0 (Continue with error clear)

- An SSR short-circuit is detected at point 1 in the diagram above. The detection condition is as follows:  
 Heater OFF current (see note 1)  $\geq$  SSR short-circuit detection value.
- The heater short circuit alarm is cleared at point 2 in the diagram above. The clearing condition is as follows:  
 Heater OFF current (see note 1)  $\leq$  SSR short-circuit detection value - Hysteresis (see note 2)

- Note**
- (1) The heater OFF current is the peak load current that flows when the G3ZA's output is OFF.
  - (2) The hysteresis setting applies a dead zone between the detection condition and clearing condition, which prevents ON/OFF chattering of the alarm. The same hysteresis setting is used for the heater burnout detection, heater overcurrent detection, and SSR short-circuit detection functions.

Variable type	Parameter name	Setting range	Default
81/C1	Channel 1 to 4 SSR short-circuit detection value	0 to 50 A (See note.)	50 (Disabled)
	CT 1 to 4 SSR short-circuit detection value ( <b>V2</b> models)	0 to 165 A, or% (See note.)	165 (Disabled)
83/C3	Hysteresis	1 to 10 A, or %	1

**Note** If set to 50 A (or 165 A in the **V2** models), SSR short-circuit will not be detected. If set to 0 A, detection is forced. Use these settings to confirm operation during installation.

**Setting Ranges Supported in the V2 Models (0 to 165 A, or %)**

The current range and units are determined by the Current Monitor Selector setting.

Variable type	Parameter name	Setting	Current range	Units
83/C3	Current Monitor Selector	0	0 to 55	A
		1	0 to 165	A
		2	0 to 110	%

**Note** Detection values of 0 to 165 (A or %) max. can be detected, but set the detection value appropriate for the current range. If the detection value is set above the current range, errors will not be detected. Refer to 4-3 *Selecting the CT (4-channel Models Only) V2* on page 33 for details on detection values.

**Example:** Setting the CT1 SSR short-circuit detection value to 20 A

- 1,2,3...**
1. Set the CT1 SSR short-circuit detection value to 20 with a Variable Area Write command.
  2. The current is detected in CT1, and SSR short-circuits are detected with the timing shown in the diagram on the preceding page.
  3. Once the CT1 SSR short-circuit detection value is written, the setting is saved, and will also be effective the next time that the power is turned ON.

**Precautions**

The actual current flowing in the heater may not be the same as the heater's rated current. Check the heater current under actual conditions using the CT1 to CT4 Heater OFF currents.

**Operation after Error Detection**

It is possible to select the Controller's operation after an SSR short-circuit is detected.

For details on selecting operation after an error, refer to 4-14 *Setting Operation at Error (4 and 8-channel Models)* on page 53.

When an SSR short-circuit has been detected, it is possible that the SSR has failed in the always-ON state so that it cannot control operation. Consider installing a failsafe circuit to cut off the power supply to the heater.

**Calculating the SSR Short-Circuit Detection Value**

Set an SSR short-circuit detection value appropriate for the customer's application.

As a rule, set a detection value that is at least two times the normal heater OFF current. Proper detection may not be possible if a value that is less than two times the normal heater OFF current is set. In additions, short-circuit detection value is set to 0 A, so set a detection value of at least 1 A.



## 4-8 Detecting Communications Timeouts (4 and 8-channel Models)

Operation can be stopped if communications cannot be performed normally for longer than the communications timeout time. In addition to stopping operation, the MV after communications error setting can also be set to output an MV to each channel after a communications error is detected.

With the upgraded **V2** models, the communications timeout time can be set in seconds.

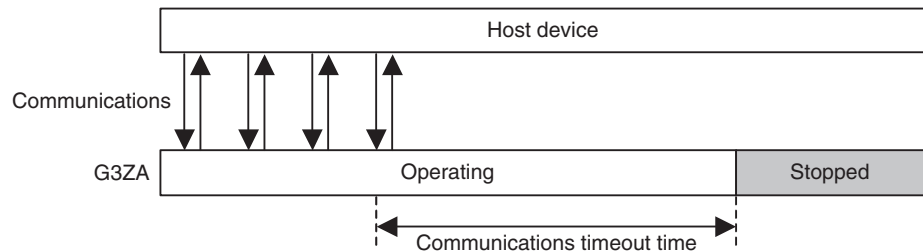

Variable type	Parameter name	Setting range	Default
83/C3	Communications timeout time	0: Disabled 1 to 60 min	0 (Disabled)
	Communications timeout time 2 (See note 1.) ( <b>V2</b> only)	0: Disabled 1 to 3,600 s	0 (Disabled)

- Note**
- (1) When the communications timeout time (minutes) is set, the same time will be reflected in communications timeout time 2 (seconds). For example, a setting of 1 minute will become 60 s.
  - (2) Communications timeouts will not be detected if the time is set to 0.
  - (3) The new setting will become valid and detection of communications timeouts will start after executing a software reset with an Operation Command or turning the power OFF and then ON again.

When a communications timeout is detected, operation will stop, and the communications error flag in the status, the ERROR indicator, and the alarm output will turn ON. To clear the error, execute a software reset or start command with an Operation Command.

<b>Error status</b>	All channels ON
<b>ERROR indicator</b>	Lit
<b>Auxiliary output</b>	ON
<b>Control output (Run)</b>	All channels stopped. The "MV after communications error" value will be output.
<b>Clearing method</b>	Execute a software reset or start command with an Operation Command.

**Example:** Setting the communications timeout time to 20 seconds

- 1,2,3...**
1. Set "communications timeout time 2" to 20 with a Variable Area Write command.
  2. After setting communications timeout time 2, enable the new setting by executing a software reset with an Operation Command or turning the power OFF and then ON again.

**Setting the MV after Communications Error**

When a communications timeout has been detected, the preset MV after communications error value can be output at each channel.

Use a Variable Area Write command to set the Channel 1 to 8 MV after communications error settings.

Variable type	Parameter name	Setting range	Default
85/C5	Channel 1 to 8 MV after communications error	0.0% to 100.0%	0.0

**Note** The Soft Increase and Soft Decrease times are applied to the “MV after communications error” outputs.

**4-9 Setting the Soft Increase and Soft Decrease Times (4 and 8-channel Models) V2**

The Soft Increase Time and Soft Decrease Time can be set to smoothly change the output level. The Soft Increase and Soft Decrease times can be set for each channel. Also, either one of the times can be set and used alone.

Variable type	Parameter name	Setting range	Default
85/C5	Channel 1 to 8 Soft Increase Time	0.0 to 99.9 s	20.0 (See note.)
	Channel 1 to 8 Soft Decrease Time	0.0 to 99.9 s	0.0 (See note.)

**Note** (1) If the Soft Increase or Soft Decrease Time is not being used, set it to 0.0 s (disabled).  
 (2) Only the Soft Increase Time is set to 20.0% as a default setting.

**Soft Increase and Soft Decrease Times Settings**

The Soft Increase Time sets the time it takes for the MV to go from 0% to 100% of its value, and the Soft Decrease Time sets the time it takes for the MV to go from 100% to 0% of its value.

Since these are continuously changed parameters, they can be changed during operation.

**Soft Increase Time**

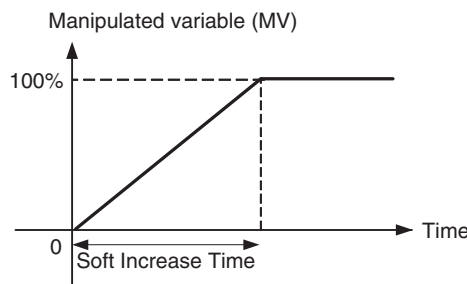

**Soft Decrease Time**

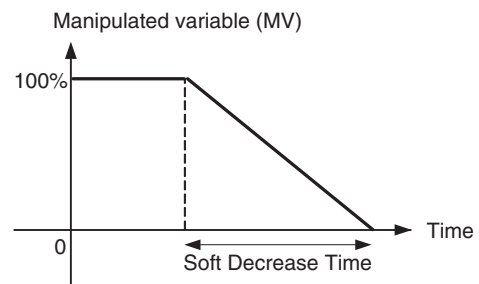

**Example:** Setting the channel 1 Soft Increase Time to 50.0 s, and the channel 1 Soft Decrease Time to 30.0 s

- 1,2,3...
1. Set the channel 1 Soft Increase Time to 50.0 with a Variable Area Write command.
  2. Set the channel 1 Soft Decrease Time to 30.0 with a Variable Area Write command.
  3. When the settings are written, they are stored and become effective the next time that the power is turned ON.

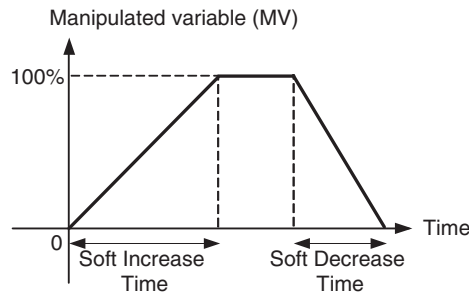

## 4-10 Changing the Manipulated Variable (4 and 8-channel Models)

The Variable Area Write command is used to change the manipulated variable. The manipulated variable is 0.0% by default when the power supplied is turned ON, but this value can be changed to a non-zero value with the Manipulated Variable Save operation command.

**Example:** Changing the manipulated variable to 20.0% when the power is turned ON

- 1,2,3...
1. Set the manipulated variables to 20.0% for all channels with a Variable Area Write command.
  2. Execute the Manipulated Variable Save operation command.
  3. The manipulated variables will be set to 20.0% the next time power is turned ON.

### Using Manipulated Variable Calculations

Manipulated variable calculations can be used to set a channel's control variable based on another channel's manipulated variable. Set the control variable with the channel 1 to 8 source channel, channel 1 to 8 slope, and channel 1 to 8 offset settings.

The following calculation method and set values can be used.

$$\text{Control variable} = (\text{Source channel's MV} \times \text{Slope} \div 100.0) + \text{Offset}$$

The following table shows the default values, which will output 100% of each channel's MV as the control variable.

Variable type	Parameter name	Setting range	Default
81/C1	Channel 1 to 8 source channel	Channel 1 to 8 (Set the channel to use as the source for calculation.)	1 to 8
	Channel 1 to 8 slope	0.0 to 400.0%	100.0
	Channel 1 to 8 offset	-400.0 to 400.0%	0.0

- Note**
- (1) If the control variable exceeds the range of 0% to 100%, it will be clamped at 0% or 100%.
  - (2) The control variable can be read using the Variable Area Read command.

**Example:** Setting the Other Channels' Control Variables Based on Channel 2's MV

The following values are set for each parameter with Variable Area Write commands.

Channel	1	2	3	4
Manipulated variable	0.0	20.0	0.0	0.0
Source channel	2	2	2	2

Channel	1	2	3	4
Slope	325.0	100.0	175.0	250.0
Offset	15.0	0.0	5.0	10.0
Control variable	80.0	20.0	40.0	60.0

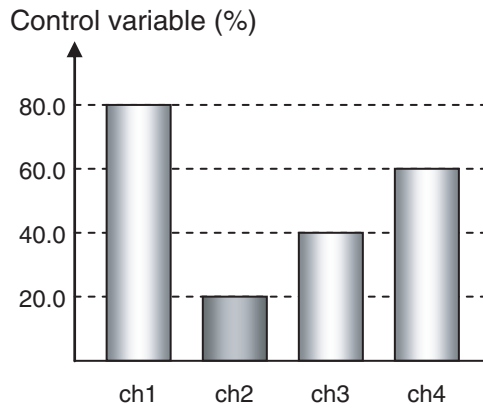

### 4-11 Offsetting the Control Output's ON Timing (4 and 8-channel Models)

Offset Control can be set to adjust the time when each channel's control output goes ON in order to reduce overlapping ON states. Offset Control is enabled by default.

Variable type	Parameter name	Setting range	Default
81/C1	Offset control	0: Disabled 1: Enabled	1 (Enabled)

#### Disabled (No Offset)

The ON timing will overlap

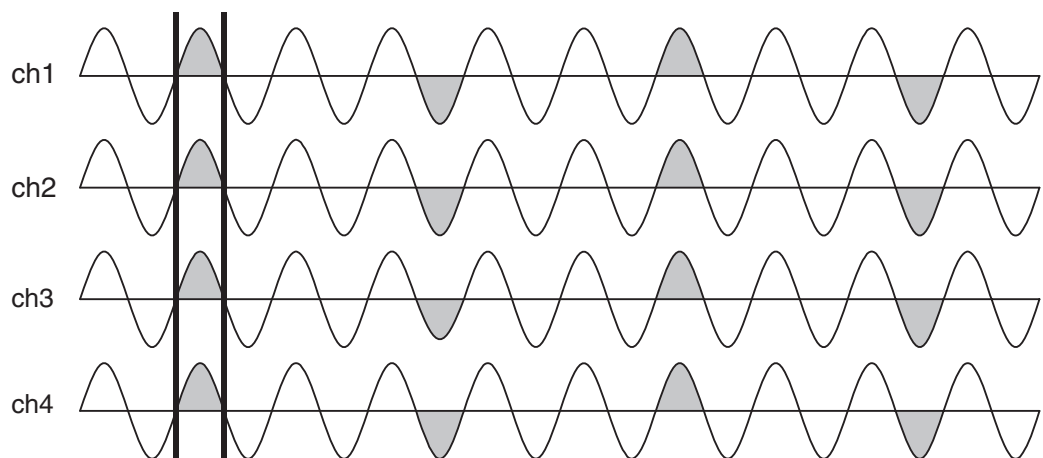

- Note**
- (1) The waveforms are current waveforms of the SSR load power supply voltage.
  - (2) The amount of overlapping depends on the control variables and the timing of control variable changes.

**Enabled (Offsets Applied)**

Overlapping of the ON outputs is reduced.

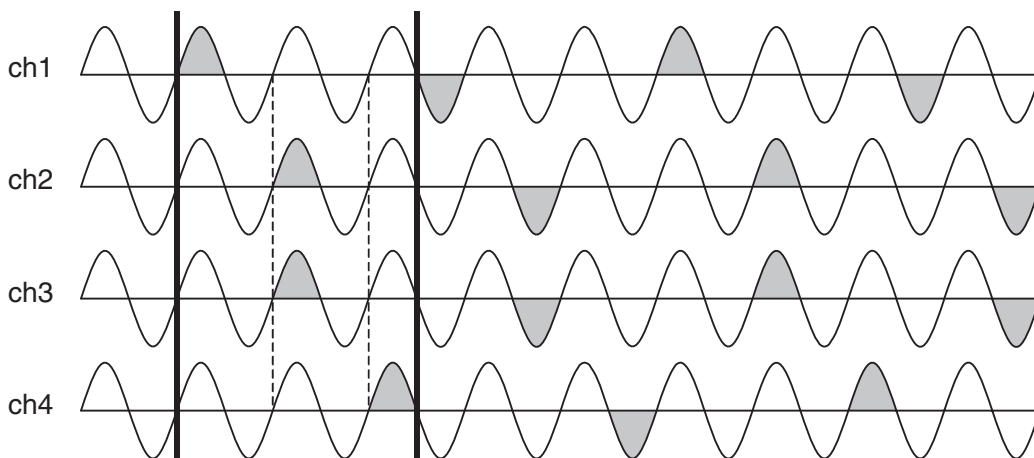

- Note**
- (1) The waveforms are current waveforms of the SSR load power supply voltage.
  - (2) The amount of overlapping depends on the control variables and the timing of control variable changes.

## 4-12 Turning OFF a Control Output (4 and 8-channel Models)

Use the start/stop operation command to turn OFF control outputs. The start/stop command can control individual channels, not just all channels at once. For details on operation commands, refer to *3-6 Operation Command* on page 25.

**Caution** Since the start/stop status is written to non-volatile memory, a channel will still be stopped when power is turned back ON if the power is turned OFF while the control output is stopped. To restart operation, use the Start/Stop operation command again.

## 4-13 Setting the Abnormal Current Detection Delay (4 and 8-channel Models) **V2**

The abnormal current detection delay can be set to prevent false detection of current errors (such as heater burnout) due to noise or other causes. Set a suitable number of detections for the usage conditions.

Variable type	Parameter name	Setting range	Default
85/C5	Abnormal current detection delay	0 to 200 detections	3 (See note.)

**Note** To output an alarm immediately when an error is detected, set the delay to 0 (disabled).

When heater burnouts, heater overcurrents, and SSR short-circuits are being detected, an abnormal current detection delay can be set to output an alarm only when the number of consecutive errors exceeds the set number of detections.

If the number of detections is set to 0, an alarm will be output immediately when an error is detected.

Use the following example as a reference when setting the number of detections.

**Example:** Setting the Abnormal Current Detection Delay to 3 Detections

**1,2,3...**

1. Set the abnormal current detection delay to 3 detections (0000 0003 hex) with a Variable Area Write command.
2. When the setting is written, it is stored and becomes effective the next time that the power is turned ON.
3. An alarm is not output even if heater burnout is detected 3 times consecutively. A heater burnout will be detected and the alarm will be output only when the heater burnout is detected consecutively 4 times or more.

Error value detected 4 consecutive times. ⇒ Alarm is output.

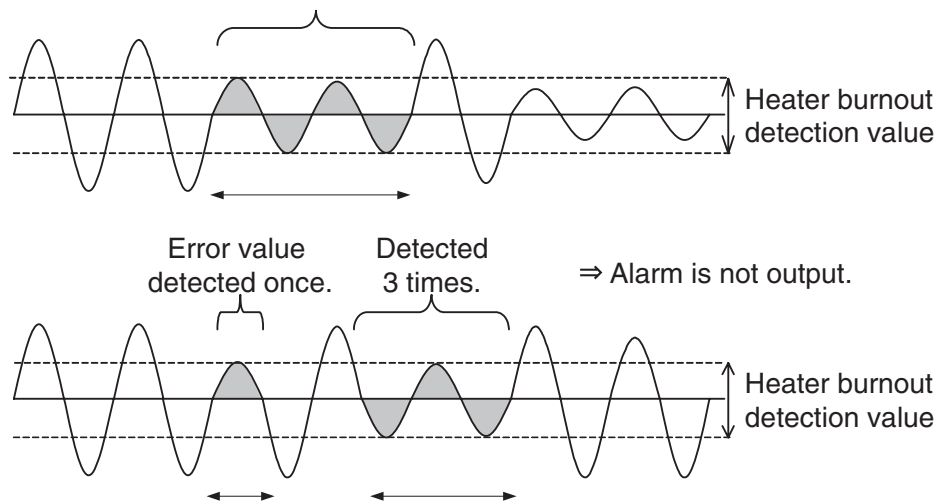

**Note**

- (1) The image shows a current waveform.
- (2) During optimum cycle control or soft-start optimum cycle control, the operation of the abnormal current detection delay is as follows:  
Output ON/OFF control and Current error detection are performed each half cycle, so the errors are detected and counted each half cycle.
- During three-phase optimum cycle control, the operation of the abnormal current detection delay is as follows:  
Output ON/OFF control and Current error detection are performed every two cycles, so the errors are detected and counted once every two cycles.

## 4-14 Setting Operation at Error (4 and 8-channel Models)

This setting can select the operation of the Controller after one of the following errors has occurred.

- Zero cross error (See note 2.)
- Heater burnout detection
- Heater overcurrent detection

- SSR short-circuit detection

Variable type	Parameter name	Setting range	Default
83/C3	Operation at Error	0: Continue with error clear 1: Continue without error clear 2: Stop	0

The following table shows the error clearing methods when an error is detected.

Setting	Operation at Error	Operation	Error clearing method
0	Continue with error clear	Continues.	When the Controller returns to normal status, the error is cleared (i.e., the status flag, ERROR indicator, and alarm output are turned OFF).
1	Continue without error clear	Continues.	The error is not cleared even when the Controller returns to normal status. Restore normal status and then execute a Start command with the Operation Command.
2	Stop	Affected channel stops. (See note 1.)	The error is not cleared and operation remains stopped even when the Controller returns to normal status. Restore normal status and then execute a Start command with the Operation Command.

- Note**
- (1) Operation will stop for all channels if a zero cross error occurs.
  - (2) A zero cross error occurs when there is an error in the load power supply voltage, frequency, or waveform. Refer to *SECTION 5 Troubleshooting* for details.

**Example:** Setting the Operation at Error Setting to “Continue without Error Clear”

- 1,2,3...**
1. Set the Operation at Error to 1 with a Variable Area Write command.
  2. When the setting is written, it is stored and becomes effective the next time that the power is turned ON.

## 4-15 Monitoring the Effective Current **V2**

The G3ZA can monitor the current read by the CT sensor as the effective current. The following formula is used to calculate the effective current that is actually displayed.

$$\text{Effective current (A)} = \text{CT Current (A)} / \sqrt{(100/\text{Control variable (\%)})}$$

- Note**
- (1) The display shows the current in 0.1 A units.
  - (2) The CT current is the heater ON current (the current flowing through the heater when the control output is ON).

The effective current is monitored with the Variable Area Read command.

Variable type	Parameter name	Monitor range	Default
8E/CE	CT1 to CT4 effective current	0.0 to 165.0 A, or % (See note.)	0.0

- Note**
- The setting range is determined by the Current Monitor Selector setting. For details, refer to *4-3 Selecting the CT (4-channel Models Only) **V2*** on page 33.

In the following cases, the display will indicate a value other than the effective current.

- Operation is stopped or a communications error occurred: 0.0 A is displayed.
- Power is turned ON or a zero-cross error occurred: 0.0 A is displayed.





# SECTION 5

## Troubleshooting

This section provides information on problems that may occur during operation and corrective measures for them.

5-1	Errors .....	58
5-2	Handling Problems .....	59

## 5-1 Errors

### Error Table

ERROR indicator	Status	Operation	Error	Correction
Lit	No response or an error response	Stops	There is an error in internal memory or in non-volatile memory.	<p>Cycle the power supply.</p> <p>If operation does not recover, use the following procedure, noting that all settings will be returned to their default values.</p> <ul style="list-style-type: none"> <li>• Error Response Received Initialize the settings and perform a software reset with an Operation Command.</li> <li>• Error Response Not Received Set the host data length, stop bits, and parity to the default values for the G3ZA (if a Converter is being used, set it to the same values) and then initialize the settings and perform a software reset with an Operation Command.</li> </ul> <p>If operation still does not recover, the G3ZA needs to be repaired.</p>
Lit	Communications error bit is ON.	Stops	A communications timeout has occurred.	<ul style="list-style-type: none"> <li>• Check to see if the communications line is broken.</li> <li>• Check to see if a communications error has occurred.</li> <li>• Check the host to see if it is functioning correctly.</li> <li>• Check the information provided in <i>4-8 Detecting Communications Timeouts (4 and 8-channel Models)</i> on page 48.</li> </ul>
Lit	Zero cross error bit is ON.	According to the operation at error setting	A zero cross error has been detected.	<ul style="list-style-type: none"> <li>• Check to see if the load power supply's voltage and frequency are within specifications. The specified ranges are as follows: Controllers with 100 to 240 V Load Voltage: 75 to 264 VAC Controllers with 400 to 480 V Load Voltage: 340 to 528 VAC Frequency (all models) : 47 to 63 Hz</li> <li>• Noise may be a factor. Check the load power supply line for noise and check the general area around the G3ZA for noise.</li> </ul>
Lit	Heater burnout bit is ON.	According to the operation at error setting	A heater burnout has been detected.	<ul style="list-style-type: none"> <li>• The heater has burned out. Repair the heater or the heater line.</li> <li>• Check the information provided in <i>4-5 Detecting Heater Burnouts (4-channel Models Only)</i> on page 36.</li> </ul>
Lit	Heater overcurrent bit is ON.	According to the operation at error setting	A heater overcurrent has been detected.	<ul style="list-style-type: none"> <li>• An overcurrent has occurred to the heater. Return the current to the correct range.</li> <li>• Check the information provided in <i>Wiring Diagrams</i> on page 12 and in <i>4-6 Detecting Heater Overcurrent (4-channel Models Only)</i> on page 43.</li> </ul>
Flashing	SSR short-circuit bit is ON.	According to the operation at error setting	An SSR short-circuit has been detected.	<ul style="list-style-type: none"> <li>• The SSR has short-circuited. Replace the SSR.</li> <li>• Check the information provided in <i>Wiring Diagrams</i> on page 12 and in <i>4-7 Detecting SSR Short-Circuits (4-channel Models Only)</i> on page 45.</li> </ul>

## 5-2 Handling Problems

### Handling Problems

#### Preliminary Checks

Check item	Items to check
Is the power supply turned ON?	If the power supply is turned ON, the READY indicator will be lit.
Was wiring performed correctly?	Check all of the wiring.
Were settings performed correctly?	<ul style="list-style-type: none"> <li>• Check the switches to see if they are set correctly.</li> <li>• Read out the settings to see if they have been set correctly.</li> <li>• Read out all settings to see if any of them are incorrect.</li> </ul>

#### Handling Problems

Condition	Correction
Communications cannot be performed.	<ul style="list-style-type: none"> <li>• If the SD/RD indicator does not light when communications are attempted, there is a problem with the communications line. Check the wiring of the communications line.</li> <li>• If a communications converter is being used, check the settings of the converter to see if they are correct.</li> <li>• Check the settings of SW1 and SW2 to see if they agree with the settings of the host.</li> <li>• Check the data length, number of stop bits, and parity to see if they are the same as the host. If any of the settings are incorrect or if any are unknown, use the following method for communications.                             <ol style="list-style-type: none"> <li>1. Set SW2 to 7. (If more than 16 communications unit numbers are used, set SW2 to F.)</li> <li>2. Set the baud rate, data length, number of stop bits, and parity of the host to the default values for the G3ZA. If a converter is being used, set the converter to the same values.</li> <li>3. This should enable communications. Change all settings to the correct values.</li> </ol> </li> <li>• Check the communications line to see if it is correct.</li> </ul>
Outputs do not turn ON.	<ul style="list-style-type: none"> <li>• Unless the OCC indicator is lit and the control variable is set to 0.0%, then there is a problem in the wiring. Check the wiring of the control outputs.</li> <li>• If the ERROR indicator is lit or flashing, refer to the corrections given in the <i>Error Table</i> on page 58.</li> </ul>
Returning settings to default values	<ul style="list-style-type: none"> <li>• Initialize the settings with an Operation Command. All of the settings can be returned to their default values. Refer to the <i>Status Lists</i> on page 65 in the <i>Appendix</i> for default values.</li> </ul>
Current cannot be detected correctly.	<ul style="list-style-type: none"> <li>• Check to see if the CT setting in the G3ZA matches the CT that is connected. Refer to 4-3 <i>Selecting the CT (4-channel Models Only)</i> <b>V2</b>.</li> </ul>
An output is not stable.	<ul style="list-style-type: none"> <li>• Check to see if the SSR setting in the G3ZA matches the SSR that is connected. Refer to 4-2 <i>Selecting the SSR (Control Method) 4 or 8-channel Models)</i> <b>V2</b>.</li> </ul>



# Appendix

## Specifications

### Specifications

#### Ratings

<b>Control power supply voltage</b>	100 to 240 VAC (50/60 Hz)
<b>Control power supply voltage range</b>	85 to 264 VAC
<b>Power consumption</b>	Approx. 5.9 W
<b>Load power supply voltage</b>	100 to 240 VAC 400 to 480 VAC
<b>Load power supply voltage range</b>	Controllers for 100 to 240 VAC: 75 to 264 VAC Controllers for 400 to 480 VAC: 340 to 528 VAC
<b>Manipulated variable inputs</b>	0.0% to 100.0% (via RS-485 communications)
<b>Trigger outputs</b>	One for each channel, 12 VDC $\pm$ 15%, max. load current: 21 mA (with built-in short-circuit protection circuit)
<b>Alarm output</b>	NPN open collector, one output (Max. load voltage: 30 VDC, max. load current: 50 mA)
<b>Indications</b>	LED indicators
<b>Ambient operating temperature</b>	-10 to 55°C (with no icing or condensation)
<b>Ambient operating humidity</b>	25% to 85%
<b>Storage temperature</b>	-25 to 65°C (with no icing or condensation)
<b>Elevation</b>	2,000 m max.
<b>Accessories</b>	Instruction Sheet

<b>Model</b>	E54-CT1/E54-CT3	G3ZA-CT150L
<b>CT input</b>	Single-phase between 0 and 50 A AC	Single-phase between 0 and 150 A AC

#### Performance

<b>Current accuracy</b>	Current range: 0 to 50 A: $\pm$ 3 A max. 0 to 150 A: $\pm$ 9 A max. 0% to 100%: $\pm$ 6% max.
<b>Insulation resistance</b>	100 M $\Omega$ min. (at 500 VDC) between primary and secondary
<b>Dielectric strength</b>	2,000 VAC, 50/60 Hz for 1 min between primary and secondary
<b>Vibration resistance</b>	Vibration frequency: 10 to 55 to 10 Hz, acceleration: 50 m/s <sup>2</sup> in X, Y, Z directions
<b>Shock resistance</b>	300 m/s <sup>2</sup> three times each in six directions along three axes
<b>Weight of main body</b>	Approx. 200 g (including terminal cover)
<b>Degree of protection</b>	IP20
<b>Memory backup</b>	EEPROM (non-volatile memory), write life: 100,000 writes
<b>Installation environment</b>	Overvoltage category III, pollution degree 2 (according to IEC 60664-1)
<b>Approved standards</b>	UL508 (Listing), CSA22.2 No. 14 EN50178 EN61000-6-4 (EN55011: 1998, A1: 1999 Class A, Group 1) EN61000-6-2: 2001

## Model Numbers

### Model Numbers

#### G3ZA-①②③④⑤-⑥-⑦

Number	Code	Specifications
①	No. of control points	4 8
		4 channels 8 channels
②	Control method	None Optimum cycle control
③	Current transformer input	H A
		Yes None
④	Load power supply voltage	2 4
		100 to 240 VAC 400 to 480 VAC
⑤	Communications specifications	03 RS-485
⑥	Communications protocol	FLK CompoWay/F
⑦	International standards	UTU Approved by TÜV.

## Current Transformer

### Specifications

Item	Specification		
Model number	E54-CT1	E54-CT3	G3ZA-CT150L
Max. continuous heater current	50 A	120 A (See note.)	150 A
Dielectric strength	1,000 VAC for 1 min		2,000 VAC for 1 min
Vibration resistance	98 m/s <sup>2</sup> , 50 Hz		
Weight	Approx. 11.5 g	Approx. 50 g	Approx. 130 g
Accessories	None	Connection terminals (2) Plugs (2)	None

**Note** The maximum continuous current of the G3ZA together with the E54-CT3 is 50 A.

### Dimensions (Unit: mm)

#### E54-CT1

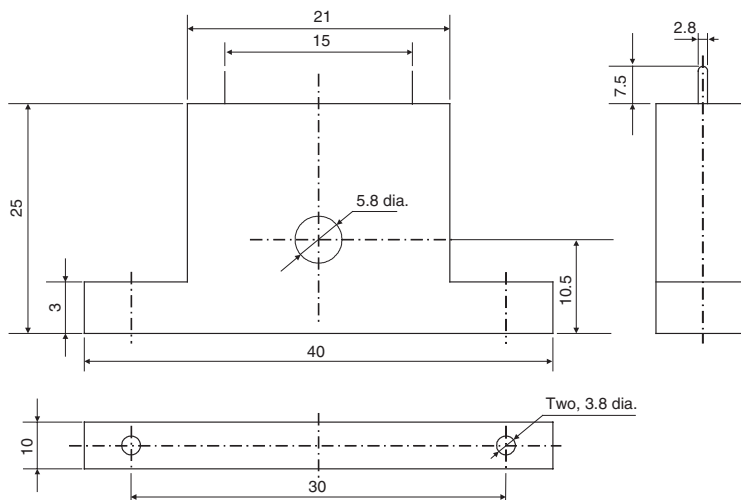

**E54-CT3**

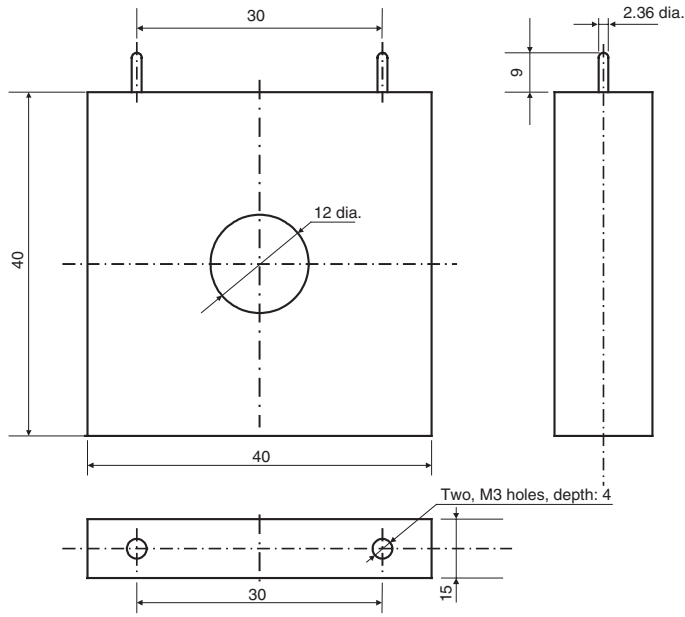

**G3ZA-CT150L**

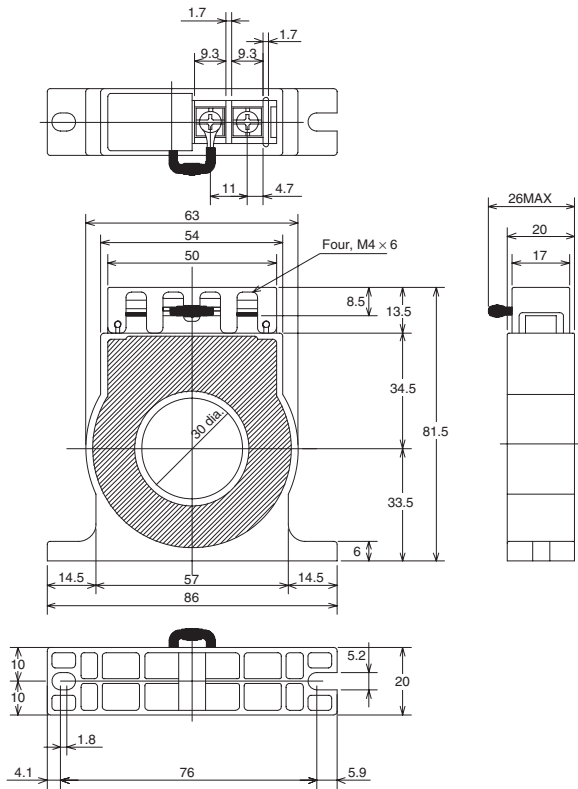



## Startup Operation

It takes about 1 second for the load power supply to stabilize after the power supply to the G3ZA is turned ON. Outputs will not turn ON during this period. A stabilization period of 1 second is also executed after clearing a zero cross error.

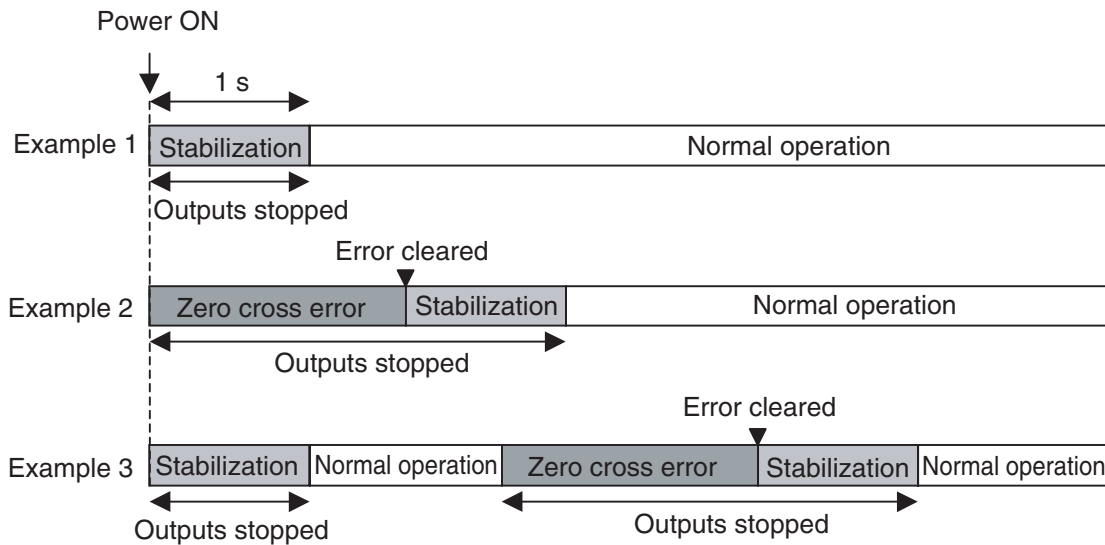

## Connecting More Than 16 Controllers

If more than 16 G3ZA Controllers are connected, set SW2 to between 8 and B for the 17th Controller on. The relationship between the settings of SW1 and SW2 is shown in the following table.

kbit/s	sw1 \ sw2	0	1	2	3	4	5	6	7	8	9	A	B	C	D	E	F
9.6	0	00	01	02	03	04	05	06	07	08	09	10	11	12	13	14	15
19.2	1																
38.4	2																
57.6	3																
---	4 to 7																
9.6	8	16	17	18	19	20	21	22	23	24	25	26	27	28	29	30	31
19.2	9																
38.4	A																
57.6	B																
---	C to F																

- Note**
- (1) Up to 31 Controllers can be connected.
  - (2) Do not set SW2 to between 4 and 7 or C and F.
  - (3) It's easiest to set the communications unit number first and then the baud rate.

**Setting example:** The following settings would be used to set a Controller to communications unit number 7 and a baud rate of 38.4 kbit/s.

SW1 = 7 and SW2 = 2

## Status Lists

Use the status listed in the following tables to check G3ZA status.

### Status

Bit	Status	OFF	ON	
31 to 13	Not used.	OFF	---	
12	Start/stop	Operating	Stopped	<b>Operating</b>
11	Not used.	OFF	---	
10	Not used.	OFF	---	
9	Alarm output (applies to all channels)	OFF	ON	<b>Output</b>
8	Control output	OFF	ON	
7	Not used.	OFF	---	
6	Not used.	OFF	---	
5	Communications error (applies to all channels)	No	Yes	<b>Error</b>
4	Zero cross error (applies to all channels)	No	Yes	
3	Not used.	OFF	---	
2	Heater overcurrent	No	Yes	
1	SSR short-circuit	No	Yes	
0	Heater burnout	No	Yes	

### Example:

Condition	Status
Alarm output and zero cross error bit are ON.	H'00000210
Stopped with no errors	H'00001000

## Parameter List

If variables without parentheses are used in communications, the set values will be eight-digit (double-word) data. If variables with parentheses are used in communications, the set values will be four-digit (word) data.

**Example:** Variable type C4: Double word (8 digits)  
Variable type 84: Word (4 digits)

## Parameter List for Pre-V2 Controllers

**Note** Refer to *Parameter List for V2 Controllers* on page 69 for parameters for upgraded Controllers.

Level	Variable type	Address	Parameter	Setting/monitor range	Default	Unit	
Operation	C0 (80)	0000	Version	---	---	---	
		0001	CH1 control variable	H'00000000 to H'000003E8 (0.0 to 100.0)	0.0	%	
		0002	CH2 control variable	H'00000000 to H'000003E8 (0.0 to 100.0)	0.0	%	
		0003	CH3 control variable	H'00000000 to H'000003E8 (0.0 to 100.0)	0.0	%	
		0004	CH4 control variable	H'00000000 to H'000003E8 (0.0 to 100.0)	0.0	%	
		0005	CH5 control variable	H'00000000 to H'000003E8 (0.0 to 100.0)	0.0	%	
		0006	CH6 control variable	H'00000000 to H'000003E8 (0.0 to 100.0)	0.0	%	
		0007	CH7 control variable	H'00000000 to H'000003E8 (0.0 to 100.0)	0.0	%	
		0008	CH8 control variable	H'00000000 to H'000003E8 (0.0 to 100.0)	0.0	%	
		0009	CH1 status	---		---	
		000A	CH2 status	---		---	
		000B	CH3 status	---		---	
		000C	CH4 status	---		---	
		000D	CH5 status	---		---	
		000E	CH6 status	---		---	
		000F	CH7 status	---		---	
		0010	CH8 status	---		---	
		0011	CH1 heater ON current	H'00000000 to H'00000037 (0 to 55)	0	A	
		0012	CH2 heater ON current	H'00000000 to H'00000037 (0 to 55)	0	A	
		0013	CH3 heater ON current	H'00000000 to H'00000037 (0 to 55)	0	A	
	0014	CH4 heater ON current	H'00000000 to H'00000037 (0 to 55)	0	A		
	0015	CH1 heater OFF current	H'00000000 to H'00000037 (0 to 55)	0	A		
	0016	CH2 heater OFF current	H'00000000 to H'00000037 (0 to 55)	0	A		
	0017	CH3 heater OFF current	H'00000000 to H'00000037 (0 to 55)	0	A		
	0018	CH4 heater OFF current	H'00000000 to H'00000037 (0 to 55)	0	A		
		C1 (81)	0000	CH1 manipulated variable	H'00000000 to H'000003E8 (0.0 to 100.0)	0.0	%
			0001	CH2 manipulated variable	H'00000000 to H'000003E8 (0.0 to 100.0)	0.0	%
			0002	CH3 manipulated variable	H'00000000 to H'000003E8 (0.0 to 100.0)	0.0	%
			0003	CH4 manipulated variable	H'00000000 to H'000003E8 (0.0 to 100.0)	0.0	%
			0004	CH5 manipulated variable	H'00000000 to H'000003E8 (0.0 to 100.0)	0.0	%
			0005	CH6 manipulated variable	H'00000000 to H'000003E8 (0.0 to 100.0)	0.0	%
			0006	CH7 manipulated variable	H'00000000 to H'000003E8 (0.0 to 100.0)	0.0	%
			0007	CH8 manipulated variable	H'00000000 to H'000003E8 (0.0 to 100.0)	0.0	%
			0008	CH1 slope	H'00000000 to H'00000FA0 (0.0 to 400.0)	100.0	%
	0009		CH2 slope	H'00000000 to H'00000FA0 (0.0 to 400.0)	100.0	%	
	000A		CH3 slope	H'00000000 to H'00000FA0 (0.0 to 400.0)	100.0	%	
	000B		CH4 slope	H'00000000 to H'00000FA0 (0.0 to 400.0)	100.0	%	
	000C		CH5 slope	H'00000000 to H'00000FA0 (0.0 to 400.0)	100.0	%	
	000D		CH6 slope	H'00000000 to H'00000FA0 (0.0 to 400.0)	100.0	%	

Level	Variable type	Address	Parameter	Setting/monitor range	Default	Unit
Operation	C1 (81)	000E	CH7 slope	H'00000000 to H'00000FA0 (0.0 to 400.0)	100.0	%
		000F	CH8 slope	H'00000000 to H'00000FA0 (0.0 to 400.0)	100.0	%
		0010	CH1 offset	H'FFFFFF060 to H'00000FA0 (-400.0 to 400.0)	0.0	%
		0011	CH2 offset	H'FFFFFF060 to H'00000FA0 (-400.0 to 400.0)	0.0	%
		0012	CH3 offset	H'FFFFFF060 to H'00000FA0 (-400.0 to 400.0)	0.0	%
		0013	CH4 offset	H'FFFFFF060 to H'00000FA0 (-400.0 to 400.0)	0.0	%
		0014	CH5 offset	H'FFFFFF060 to H'00000FA0 (-400.0 to 400.0)	0.0	%
		0015	CH6 offset	H'FFFFFF060 to H'00000FA0 (-400.0 to 400.0)	0.0	%
		0016	CH7 offset	H'FFFFFF060 to H'00000FA0 (-400.0 to 400.0)	0.0	%
		0017	CH8 offset	H'FFFFFF060 to H'00000FA0 (-400.0 to 400.0)	0.0	%
		0018	CH1 source channel	H'00000001 to H'00000008 (1 to 8)	1	---
		0019	CH2 source channel	H'00000001 to H'00000008 (1 to 8)	2	---
		001A	CH3 source channel	H'00000001 to H'00000008 (1 to 8)	3	---
		001B	CH4 source channel	H'00000001 to H'00000008 (1 to 8)	4	---
		001C	CH5 source channel	H'00000001 to H'00000008 (1 to 8)	5	---
		001D	CH6 source channel	H'00000001 to H'00000008 (1 to 8)	6	---
		001E	CH7 source channel	H'00000001 to H'00000008 (1 to 8)	7	---
		001F	CH8 source channel	H'00000001 to H'00000008 (1 to 8)	8	---
		0020	CH1 heater burnout detection value	H'00000000 to H'00000032 (0 to 50)	0	A
		0021	CH2 heater burnout detection value	H'00000000 to H'00000032 (0 to 50)	0	A
		0022	CH3 heater burnout detection value	H'00000000 to H'00000032 (0 to 50)	0	A
		0023	CH4 heater burnout detection value	H'00000000 to H'00000032 (0 to 50)	0	A
		0024	CH1 SSR short-circuit detection value	H'00000000 to H'00000032 (0 to 50)	50	A
		0025	CH2 SSR short-circuit detection value	H'00000000 to H'00000032 (0 to 50)	50	A
		0026	CH3 SSR short-circuit detection value	H'00000000 to H'00000032 (0 to 50)	50	A
		0027	CH4 SSR short-circuit detection value	H'00000000 to H'00000032 (0 to 50)	50	A
		0028	CH1 heater overcurrent detection value	H'00000000 to H'00000032 (0 to 50)	50	A
		0029	CH2 heater overcurrent detection value	H'00000000 to H'00000032 (0 to 50)	50	A
		002A	CH3 heater overcurrent detection value	H'00000000 to H'00000032 (0 to 50)	50	A
		002B	CH4 heater overcurrent detection value	H'00000000 to H'00000032 (0 to 50)	50	A
		002C	Offset control	H'00000000 (Disabled) H'00000001 (Enabled)	Enabled	---

Level	Variable type	Address	Parameter	Setting/monitor range	Default	Unit
Operation	C3 (83)	0000	Data length (See note 2.)	H'00000000 (7) H'00000001 (8)	7	bits
		0001	Stop bits (See note 2.)	H'00000000 (1) H'00000001 (2)	2	bits
		0002	Parity (See note 2.)	H'00000000 (None) H'00000001 (Even) H'00000002 (Odd)	Even	---
		0003	Send standby time (See note 2.)	H'00000000 to H'00000063 (0 to 99)	20	ms
		0004	Communications timeout time (See note 2.)	H'00000000 (Disabled) H'00000001 to H'0000003C (1 to 60)	0	min
		0005	Operation at error	H'00000000 (Continue with error clear) H'00000001 (Continue with no error clear) H'00000002 (Stop) (See note 2.)	0	---
		0006	Offset value	H'00000000 to H'000003E8 (0.0 to 100.0)	20.0	%
		0007	Hysteresis	H'00000001 to H'0000000A (1 to 10)	1	A

- Note** (1) These settings are valid after the G3ZA is reset with an operation command or after the power is turned ON again.
- (2) Only the channel with the error will stop.



## Parameter List for V2 Controllers

Level	Variable type	Address	Parameter name	Setting/monitor range	Default	Unit	
Operation	C0 (80)	0000	Version	---	---	---	
		0001	CH1 control variable	H'00000000 to H'000003E8 (0.0 to 100.0)	0.0	%	
		0002	CH2 control variable	H'00000000 to H'000003E8 (0.0 to 100.0)	0.0	%	
		0003	CH3 control variable	H'00000000 to H'000003E8 (0.0 to 100.0)	0.0	%	
		0004	CH4 control variable	H'00000000 to H'000003E8 (0.0 to 100.0)	0.0	%	
		0005	CH5 control variable	H'00000000 to H'000003E8 (0.0 to 100.0)	0.0	%	
		0006	CH6 control variable	H'00000000 to H'000003E8 (0.0 to 100.0)	0.0	%	
		0007	CH7 control variable	H'00000000 to H'000003E8 (0.0 to 100.0)	0.0	%	
		0008	CH8 control variable	H'00000000 to H'000003E8 (0.0 to 100.0)	0.0	%	
		0009	CH1 status	---	---	---	
		000A	CH2 status	---	---	---	
		000B	CH3 status	---	---	---	
		000C	CH4 status	---	---	---	
		000D	CH5 status	---	---	---	
		000E	CH6 status	---	---	---	
		000F	CH7 status	---	---	---	
		0010	CH8 status	---	---	---	
		0011	CT1 heater ON current	H'00000000 to H'000000A5 (0 to 165)	0	A or %	
	0012	CT2 heater ON current	H'00000000 to H'000000A5 (0 to 165)	0	A or %		
	0013	CT3 heater ON current	H'00000000 to H'000000A5 (0 to 165)	0	A or %		
	0014	CT4 heater ON current	H'00000000 to H'000000A5 (0 to 165)	0	A or %		
	0015	CT1 heater OFF current	H'00000000 to H'000000A5 (0 to 165)	0	A or %		
	0016	CT2 heater OFF current	H'00000000 to H'000000A5 (0 to 165)	0	A or %		
	0017	CT3 heater OFF current	H'00000000 to H'000000A5 (0 to 165)	0	A or %		
	0018	CT4 heater OFF current	H'00000000 to H'000000A5 (0 to 165)	0	A or %		
		CE (8E)	0000	CH1 control variable	H'00000000 to H'000003E8 (0.0 to 100.0)	0.0	%
			0001	CH2 control variable	H'00000000 to H'000003E8 (0.0 to 100.0)	0.0	%
			0002	CH3 control variable	H'00000000 to H'000003E8 (0.0 to 100.0)	0.0	%
			0003	CH4 control variable	H'00000000 to H'000003E8 (0.0 to 100.0)	0.0	%
			0004	CH1 status	---	---	---
			0005	CH2 status	---	---	---
			0006	CH3 status	---	---	---
			0007	CH4 status	---	---	---
			0008	CT1 effective current	H'00000000 to H'00000672 (0.0 to 165.0)	0.0	A or %
	0009		CT2 effective current	H'00000000 to H'00000672 (0.0 to 165.0)	0.0	A or %	
	000A		CT3 effective current	H'00000000 to H'00000672 (0.0 to 165.0)	0.0	A or %	
	000B		CT4 effective current	H'00000000 to H'00000672 (0.0 to 165.0)	0.0	A or %	
	000C	CT1 heater ON current	H'00000000 to H'000000A5 (0 to 165)	0	A or %		

V2

Level	Variable type	Address	Parameter name	Setting/monitor range	Default	Unit
Operation	CE (8E)	000D	CT2 heater ON current	H'00000000 to H'000000A5 (0 to 165)	0	A or %
		000E	CT3 heater ON current	H'00000000 to H'000000A5 (0 to 165)	0	A or %
		000F	CT4 heater ON current	H'00000000 to H'000000A5 (0 to 165)	0	A or %
		0010	CT1 heater OFF current	H'00000000 to H'000000A5 (0 to 165)	0	A or %
		0011	CT2 heater OFF current	H'00000000 to H'000000A5 (0 to 165)	0	A or %
		0012	CT3 heater OFF current	H'00000000 to H'000000A5 (0 to 165)	0	A or %
		0013	CT4 heater OFF current	H'00000000 to H'000000A5 (0 to 165)	0	A or %
		0014	Version	---	---	---
	C1 (81)	0000	CH1 manipulated variable	H'00000000 to H'000003E8 (0.0 to 100.0)	0.0	%
		0001	CH2 manipulated variable	H'00000000 to H'000003E8 (0.0 to 100.0)	0.0	%
		0002	CH3 manipulated variable	H'00000000 to H'000003E8 (0.0 to 100.0)	0.0	%
		0003	CH4 manipulated variable	H'00000000 to H'000003E8 (0.0 to 100.0)	0.0	%
		0004	CH5 manipulated variable	H'00000000 to H'000003E8 (0.0 to 100.0)	0.0	%
		0005	CH6 manipulated variable	H'00000000 to H'000003E8 (0.0 to 100.0)	0.0	%
		0006	CH7 manipulated variable	H'00000000 to H'000003E8 (0.0 to 100.0)	0.0	%
		0007	CH8 manipulated variable	H'00000000 to H'000003E8 (0.0 to 100.0)	0.0	%
		0008	CH1 calculated slope	H'00000000 to H'00000FA0 (0.0 to 400.0)	100.0	%
		0009	CH2 calculated slope	H'00000000 to H'00000FA0 (0.0 to 400.0)	100.0	%
		000A	CH3 calculated slope	H'00000000 to H'00000FA0 (0.0 to 400.0)	100.0	%
		000B	CH4 calculated slope	H'00000000 to H'00000FA0 (0.0 to 400.0)	100.0	%
		000C	CH5 calculated slope	H'00000000 to H'00000FA0 (0.0 to 400.0)	100.0	%
		000D	CH6 calculated slope	H'00000000 to H'00000FA0 (0.0 to 400.0)	100.0	%
		000E	CH7 calculated slope	H'00000000 to H'00000FA0 (0.0 to 400.0)	100.0	%
		000F	CH8 calculated slope	H'00000000 to H'00000FA0 (0.0 to 400.0)	100.0	%
		0010	CH1 offset	H'FFFFFF06 to H'00000FA0 (-400.0 to 400.0)	0.0	%
		0011	CH2 offset	H'FFFFFF06 to H'00000FA0 (-400.0 to 400.0)	0.0	%
		0012	CH3 offset	H'FFFFFF06 to H'00000FA0 (-400.0 to 400.0)	0.0	%
		0013	CH4 offset	H'FFFFFF06 to H'00000FA0 (-400.0 to 400.0)	0.0	%
		0014	CH5 offset	H'FFFFFF06 to H'00000FA0 (-400.0 to 400.0)	0.0	%
		0015	CH6 offset	H'FFFFFF06 to H'00000FA0 (-400.0 to 400.0)	0.0	%
		0016	CH7 offset	H'FFFFFF06 to H'00000FA0 (-400.0 to 400.0)	0.0	%
		0017	CH8 offset	H'FFFFFF06 to H'00000FA0 (-400.0 to 400.0)	0.0	%
		0018	CH1 source channel	H'00000001 to H'00000008 (1 to 8)	1	---
		0019	CH2 source channel	H'00000001 to H'00000008 (1 to 8)	2	---
		001A	CH3 source channel	H'00000001 to H'00000008 (1 to 8)	3	---
		001B	CH4 source channel	H'00000001 to H'00000008 (1 to 8)	4	---
		001C	CH5 source channel	H'00000001 to H'00000008 (1 to 8)	5	---
		001D	CH6 source channel	H'00000001 to H'00000008 (1 to 8)	6	---
		001E	CH7 source channel	H'00000001 to H'00000008 (1 to 8)	7	---
		001F	CH8 source channel	H'00000001 to H'00000008 (1 to 8)	8	---
		0020	CT1 heater burnout detection value	H'00000000 to H'000000A5 (0 to 165)	0	A or %
0021		CT2 heater burnout detection value	H'00000000 to H'000000A5 (0 to 165)	0	A or %	
0022		CT3 heater burnout detection value	H'00000000 to H'000000A5 (0 to 165)	0	A or %	
0023	CT4 heater burnout detection value	H'00000000 to H'000000A5 (0 to 165)	0	A or %		

V2

Level	Variable type	Address	Parameter name	Setting/monitor range	Default	Unit
Operation	C1 (81)	0024	CT1 SSR short-circuit detection value	H'00000000 to H'000000A5 (0 to 165)	165	A or %
		0025	CT2 SSR short-circuit detection value	H'00000000 to H'000000A5 (0 to 165)	165	A or %
		0026	CT3 SSR short-circuit detection value	H'00000000 to H'000000A5 (0 to 165)	165	A or %
		0027	CT4 SSR short-circuit detection value	H'00000000 to H'000000A5 (0 to 165)	165	A or %
		0028	CT1 heater overcurrent detection value	H'00000000 to H'000000A5 (0 to 165)	165	A or %
		0029	CT2 heater overcurrent detection value	H'00000000 to H'000000A5 (0 to 165)	165	A or %
		002A	CT3 heater overcurrent detection value	H'00000000 to H'000000A5 (0 to 165)	165	A or %
		002B	CT4 heater overcurrent detection value	H'00000000 to H'000000A5 (0 to 165)	165	A or %
		002C	Offset control	H'00000000 (Disabled) H'00000001 (Enabled)	1	---
	C3 (83)	0000	Communications data length (See note 1.)	H'00000000 (7) H'00000001 (8)	7	bit
		0001	Communications stop bits (See note 1.)	H'00000000 (1) H'00000001 (2)	2	bit
		0002	Communications parity (See note 1.)	H'00000000 (Note) H'00000001 (Even) H'00000002 (Odd)	1	---
		0003	Communications send standby time (See note 1.)	H'00000000 to H'00000063 (0 to 99)	1	ms
		0004	Communications timeout time (See note 1.)	H'00000000 (Disabled) H'00000001 to H'0000003C (1 to 60)	0	min
		0005	Operation at error	H'00000000 (Continue with error clear) H'00000001 (Continue with no error clear) H'00000002 (Stop) (See note 2.)	0	---
		0006	Offset value	H'00000000 to H'0000003E8 (0.0 to 100.0)	20.0	%
		0007	Hysteresis	H'00000001 to H'0000000A (1 to 10)	1	A or %
		0008	SSR drive selection (See note 1.)	H'00000000: SSR for single-phase heater with zero-cross function: Optimum cycle control H'00000001: SSR for single-phase heater without zero-cross function: Soft-start optimum cycle control H'00000002: SSR for three-phase heater with zero-cross function: Three-phase optimum cycle control	0	---
		0009	Current monitor display selection (See note 1.)	H'00000000 (0 to 50 A) H'00000001 (0 to 150 A) H'00000002 (0% to 100%)	0	---
000A	Control switchover hysteresis (See note 1.)	H'00000000 to H'00000012C (0.0 to 30.0)	1.0	%		
000B	Communications timeout time 2 (See note 1.)	H'00000000 (Disabled) H'00000001 to H'000000E10 (1 to 3600)	0	s		
000C	CT1 assignment (See note 1.)	H'00000000 (Disabled) H'00000001 (ch1) H'00000002 (ch2) H'00000003 (ch3) H'00000004 (ch4)	1	---		
000D	CT2 assignment (See note 1.)		2	---		
000E	CT3 assignment (See note 1.)		3	---		
000F	CT4 assignment (See note 1.)		4	---		



Level	Variable type	Address	Parameter name	Setting/monitor range	Default	Unit
Operation	C5 (85)	0000	CH1 soft increase time	H'00000000 to H'000003E7 (0.0 to 99.9)	20.0	s
		0001	CH2 soft increase time	H'00000000 to H'000003E7 (0.0 to 99.9)	20.0	s
		0002	CH3 soft increase time	H'00000000 to H'000003E7 (0.0 to 99.9)	20.0	s
		0003	CH4 soft increase time	H'00000000 to H'000003E7 (0.0 to 99.9)	20.0	s
		0004	CH5 soft increase time	H'00000000 to H'000003E7 (0.0 to 99.9)	20.0	s
		0005	CH6 soft increase time	H'00000000 to H'000003E7 (0.0 to 99.9)	20.0	s
		0006	CH7 soft increase time	H'00000000 to H'000003E7 (0.0 to 99.9)	20.0	s
		0007	CH8 soft increase time	H'00000000 to H'000003E7 (0.0 to 99.9)	20.0	s
		0008	CH1 soft decrease time	H'00000000 to H'000003E7 (0.0 to 99.9)	0.0	s
		0009	CH2 soft decrease time	H'00000000 to H'000003E7 (0.0 to 99.9)	0.0	s
		000A	CH3 soft decrease time	H'00000000 to H'000003E7 (0.0 to 99.9)	0.0	s
		000B	CH4 soft decrease time	H'00000000 to H'000003E7 (0.0 to 99.9)	0.0	s
		000C	CH5 soft decrease time	H'00000000 to H'000003E7 (0.0 to 99.9)	0.0	s
		000D	CH6 soft decrease time	H'00000000 to H'000003E7 (0.0 to 99.9)	0.0	s
		000E	CH7 soft decrease time	H'00000000 to H'000003E7 (0.0 to 99.9)	0.0	s
		000F	CH8 soft decrease time	H'00000000 to H'000003E7 (0.0 to 99.9)	0.0	s
		0010	CH1 switching MV threshold	H'00000000 to H'000003E8 (0.0 to 100.0)	20.0	%
		0011	CH2 switching MV threshold	H'00000000 to H'000003E8 (0.0 to 100.0)	20.0	%
		0012	CH3 switching MV threshold	H'00000000 to H'000003E8 (0.0 to 100.0)	20.0	%
		0013	CH4 switching MV threshold	H'00000000 to H'000003E8 (0.0 to 100.0)	20.0	%
		0014	CH5 switching MV threshold	H'00000000 to H'000003E8 (0.0 to 100.0)	20.0	%
		0015	CH6 switching MV threshold	H'00000000 to H'000003E8 (0.0 to 100.0)	20.0	%
		0016	CH7 switching MV threshold	H'00000000 to H'000003E8 (0.0 to 100.0)	20.0	%
		0017	CH8 switching MV threshold	H'00000000 to H'000003E8 (0.0 to 100.0)	20.0	%
		0018	CH1 operation at communications error	H'00000000 to H'000003E8 (0.0 to 100.0)	0.0	%
		0019	CH2 operation at communications error	H'00000000 to H'000003E8 (0.0 to 100.0)	0.0	%
		001A	CH3 operation at communications error	H'00000000 to H'000003E8 (0.0 to 100.0)	0.0	%
		001B	CH4 operation at communications error	H'00000000 to H'000003E8 (0.0 to 100.0)	0.0	%
001C	CH5 operation at communications error	H'00000000 to H'000003E8 (0.0 to 100.0)	0.0	%		
001D	CH6 operation at communications error	H'00000000 to H'000003E8 (0.0 to 100.0)	0.0	%		
001E	CH7 operation at communications error	H'00000000 to H'000003E8 (0.0 to 100.0)	0.0	%		
001F	CH8 operation at communications error	H'00000000 to H'000003E8 (0.0 to 100.0)	0.0	%		
0020	Current error detection delay	H'00000000 to H'000000C8 (0 to 200)	3	Times		

- Note** (1) These settings are valid after the G3ZA is reset with an operation command or after the power is turned ON again.
- (2) Only the channel with the error will stop.

## ASCII Table

Leftmost digit Rightmost digit	0	1	2	3	4	5	6	7
0	NUL	DLE	SPACE	0	@	P	`	p
1	SOH	DC1	!	1	A	Q	a	q
2	STX	DC2	“	2	B	R	b	r
3	ETX	DC3	#	3	C	S	c	s
4	EOT	DC4	\$	4	D	T	d	t
5	ENQ	NAK	%	5	E	U	e	u
6	ACK	SYN	&	6	F	V	f	v
7	BEL	ETB	‘	7	G	W	g	w
8	BS	CAN	(	8	H	X	h	x
9	HT	EM	)	9	I	Y	i	y
A	LF	SUB	*	:	J	Z	j	z
B	VT	ESC	+	;	K	[	k	{
C	FF	FS	,	<	L	¥	l	
D	CR	GS	-	=	M	]	m	}
E	SO	RS	.	>	N	^	n	~
F	SI	US	/	?	O	_	o	DEL



# Index

## A

alarm output, 2  
  terminals on 200-V Controllers, 13  
  terminals on 400-V Controllers, 13  
ASCII table, 73

## B

baud rate, 18

## C

calculating the heater overcurrent detection value, 45  
communications specifications, 18  
communications terminals, 12  
communications unit number, 18  
CompoWay/F, 19  
  end codes, 20  
connection examples, 14  
control channels  
  maximum number, 2  
control power supply  
  terminals, 12  
controller attributes  
  reading, 26  
controller status  
  reading, 27  
crimp terminals, 12  
current monitor selector, 33  
current transformer, 62  
  input terminals, 14  
  selecting the CT, 33

## D

data length, 18  
dimensions, 8

## E

E54-CT1, 62  
E54-CT3, 63  
echo-back test, 28  
error detection, 2  
ERROR indicator, 4

errors  
  table, 58

## F

FINS-mini  
  command and response text, 21  
functional upgrades, xiii

## G

G3ZA-CT150L, 63

## H

heater OFF current, 46  
heater ON current, 37, 43

## I

initializing settings, 25  
installation, 2, 8  
  mounting, 8  
  removing, 9  
  using screws, 10

## L

load power supply input, 12

## M

manipulated variable  
  calculations, 2  
  saving, 25  
model numbers, 62  
monitoring the effective current, 54  
MRC, 21

## O

OCC indicator, 4  
offset control, 2  
operation command, 25

## **P**

parameter list, 66

## **R**

READY indicator, 4  
resetting  
    software reset, 25  
RS-485 communications, 12

## **S**

SD/RD indicator, 4  
send standby time, 18, 19  
set values  
    reading, 24  
    writing, 23  
setting the abnormal current detection delay, 52  
setup procedure, 30  
soft increase and soft decrease times, 49  
soft-start optimum cycle control, 2, 31  
specifications, 61  
SRC, 21  
SSR, 2  
    calculating the SSR short-circuit detection value, 47  
    detecting SSR short-circuits, 45  
    drive selection, 2  
starting operation, 25  
startup operation, 64  
status lists, 65  
stop bits, 18  
stopping operation, 25  
switches  
    SW1, 4  
    SW2, 4  
switching MV threshold for channels, 32

## **T**

three-phase optimum cycle control, 2, 32  
trigger outputs, 13  
troubleshooting, 57  
    handling problems, 59

## **V**

V2 (Version 2), xiii  
variable type, 21

## **W**

wiring example, 14

## Revision History

A manual revision code appears as a suffix to the catalog number on the front cover of the manual.

Cat. No. Z200-E1-02

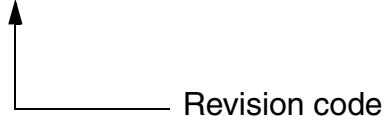

The following table outlines the changes made to the manual during each revision. Page numbers refer to the previous version.

Revision code	Date	Revised content
01	April 2004	Original production
02	February 2007	Made additions and changes for upgraded version (V2) of the Controller.

---

*Revision History*

---

# OMRON

**OMRON Corporation**  
Industrial Automation Company

**Control Devices Division H.Q.**  
**Analog Controller Division**  
Shiokoji Horikawa, Shimogyo-ku,  
Kyoto, 600-8530 Japan  
Tel: (81)75-344-7080/Fax: (81)75-344-7189

**Regional Headquarters**

**OMRON EUROPE B.V.**  
Wegalaan 67-69, NL-2132 JD Hoofddorp  
The Netherlands  
Tel: (31)2356-81-300/Fax: (31)2356-81-388

**OMRON ELECTRONICS LLC**  
1 East Commerce Drive, Schaumburg, IL 60173  
U.S.A.  
Tel: (1)847-843-7900/Fax: (1)847-843-8568

**OMRON ASIA PACIFIC PTE. LTD.**  
83 Clemenceau Avenue,  
#11-01, UE Square,  
239920 Singapore  
Tel: (65)6835-3011/Fax: (65)6835-2711

**OMRON (CHINA) CO., LTD.**  
Room 2211, Bank of China Tower,  
200 Yin Cheng Road (M),  
Shanghai, 200120 China  
Tel: (86)21-5037-2222/Fax: (86)21-5037-2200

**Authorized Distributor:**